

# CE 102: CIVIL ENGINEERING DRAWING



# ISOMETRIC PROJECTION

**Samiha Tahseen**

Lecturer, Department of Civil Engineering  
University of Asia Pacific (UAP), Dhaka

# CHAPTER – 5

# ISOMETRIC PROJECTION

“Iso” means ‘equal’ and “metric projection” means ‘a projection to a reduced measure’. An *isometric projection* is one type of pictorial projection in which the three dimensions of a solid are not only shown in one view, but also their dimension can be scaled from this drawing.



# REGULAR HEXAGON

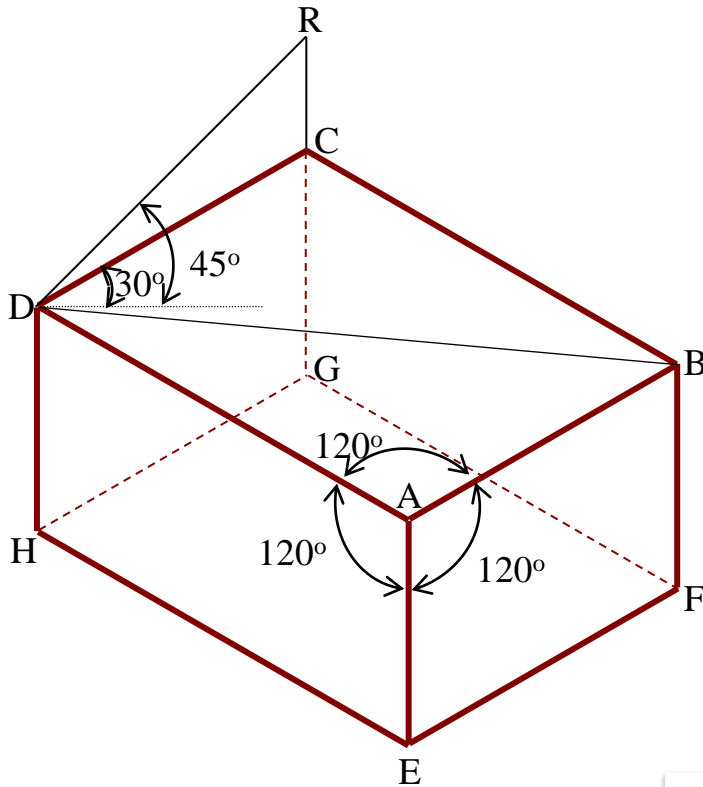

**Fig. 1**

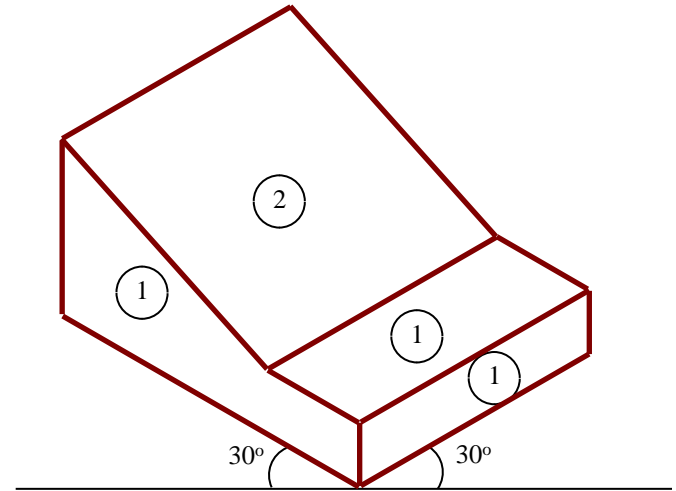

**Fig. 2**

**Isometric Axes:** AD, AE & AB

**Isometric Lines:** EH, BF etc.

**Non-isometric Lines:** DB

**Isometric Planes:** ADHE & 1 (in Fig. 1)

**Non-isometric Planes:** Plane 2 (in Fig. 2)

# ISOMETRIC SCALE

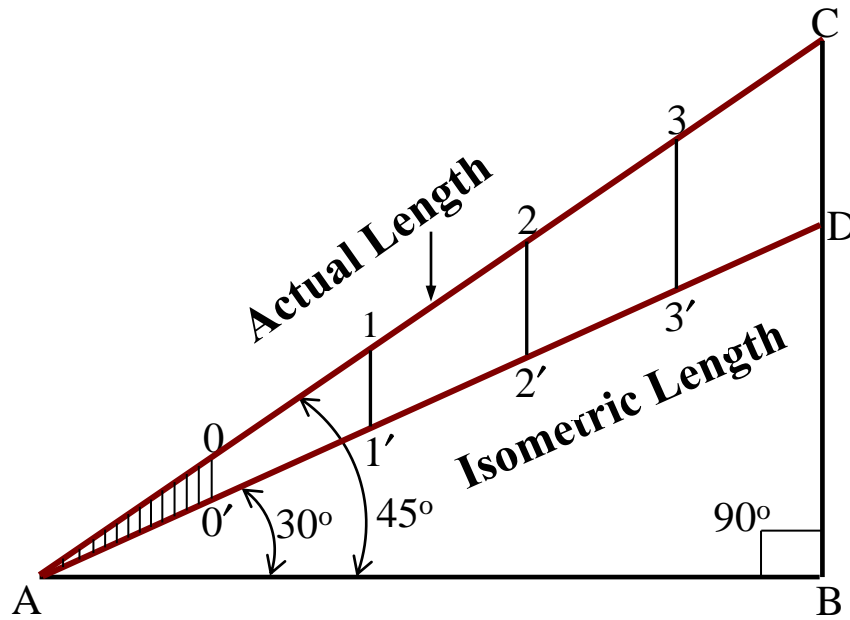

$\therefore$  Isometric Length =  $0.81 \times$  Actual Length

$$\frac{AB}{AC} = \cos 45^\circ = \frac{1}{\sqrt{2}}$$

$$\frac{AB}{AD} = \cos 30^\circ = \frac{\sqrt{3}}{2}$$

$$\therefore \frac{AB}{AC} \div \frac{AB}{AD} = \frac{1}{\sqrt{2}} \div \frac{\sqrt{3}}{2}$$

$$\frac{AB}{AC} \times \frac{AD}{AB} = \frac{1}{\sqrt{2}} \times \frac{2}{\sqrt{3}}$$

$$\frac{AD}{AC} = \sqrt{\frac{2}{3}} = 0.81$$

$$\Rightarrow AD = 0.81 \times AC$$

**Draw the isometric projection of a rectangular prism of base  $50\text{ mm} \times 10\text{ mm}$  and height  $75\text{ mm}$ , when it rests with its base on H.P and one its of rectangular faces is parallel to V.P**

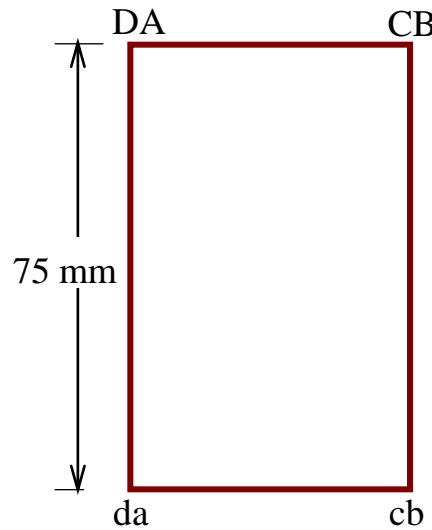

**FRONT VIEW**

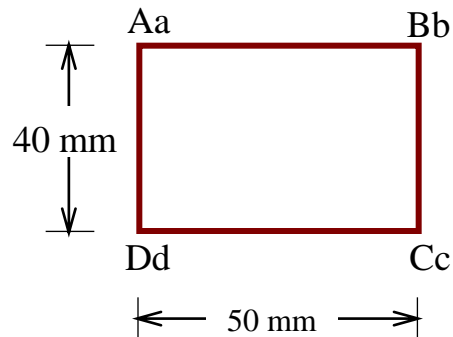

**TOP VIEW**

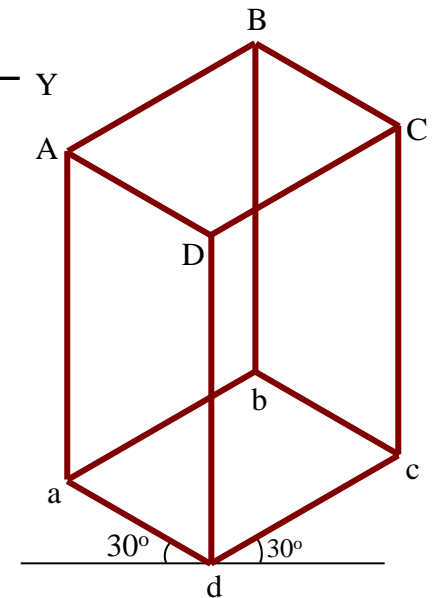
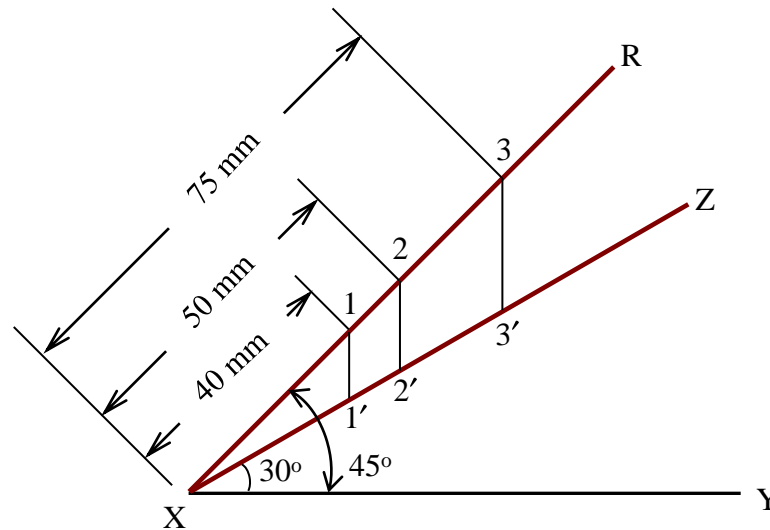

## Difference between Isometric Projection & Isometric View

Isometric View	Isometric Projection
Drawn to actual scale	Drawn to isometric scale
When lines are drawn parallel to isometric axes, the true lengths are laid off.	When lines are drawn parallel to isometric axes, the lengths are foreshortened to 0.81 time the actual lengths.

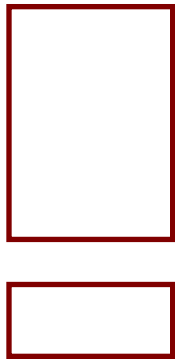

ORTHOGRAPHIC  
PROJECTION

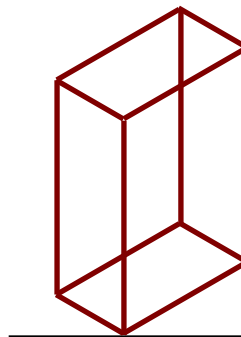

ISOMETRIC  
PROJECTION

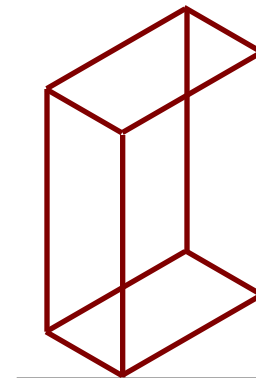

ISOMETRIC  
VIEW

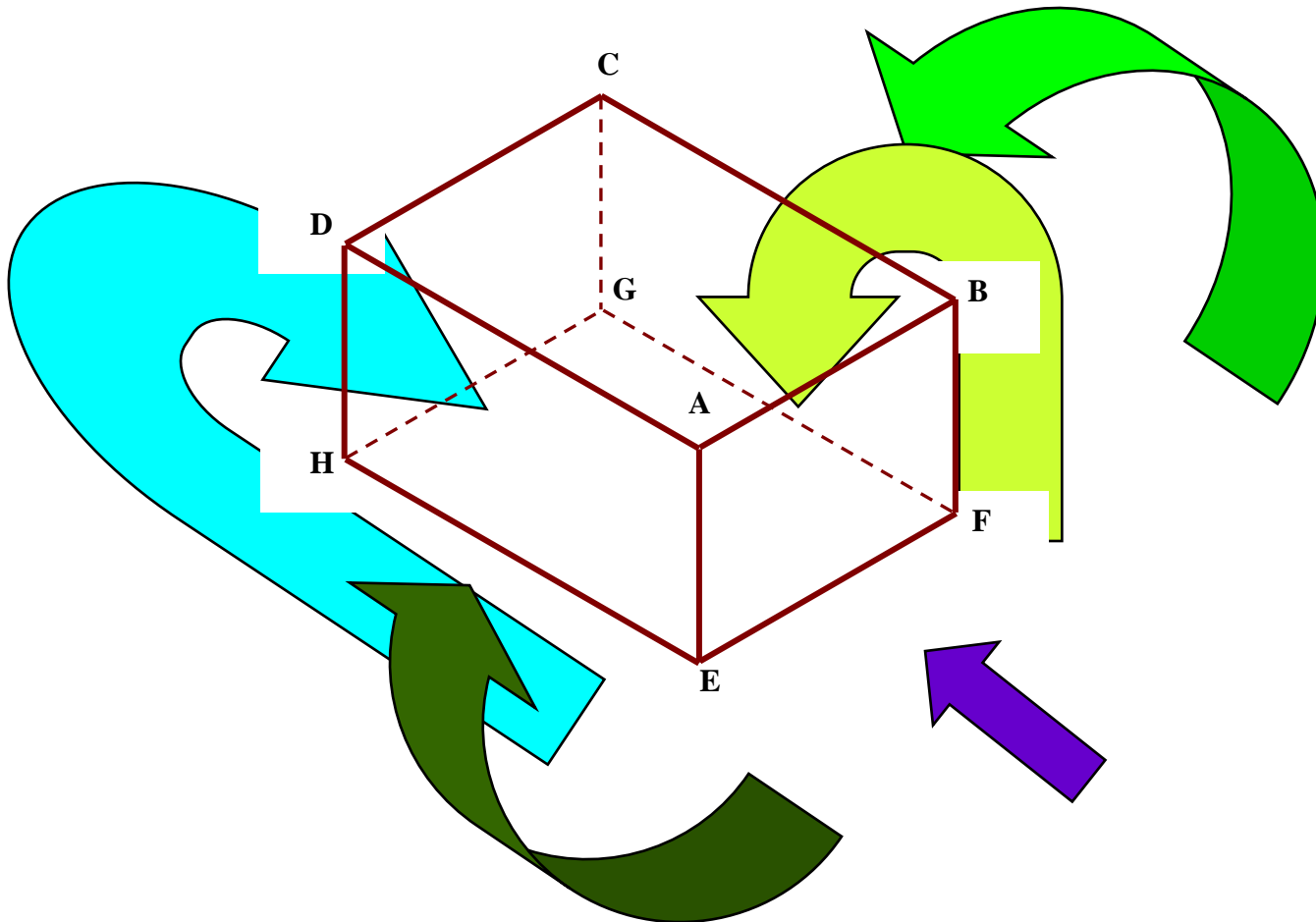

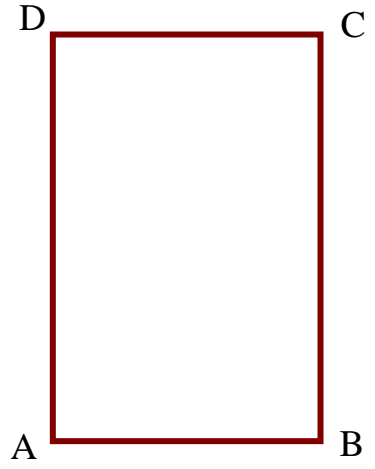
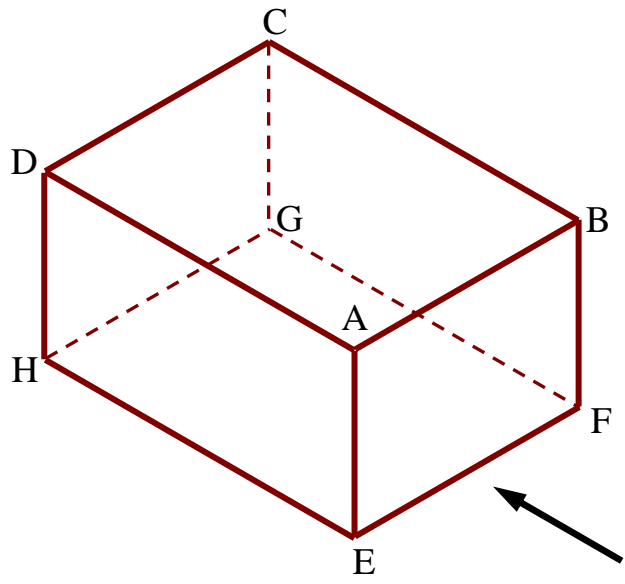

Top View

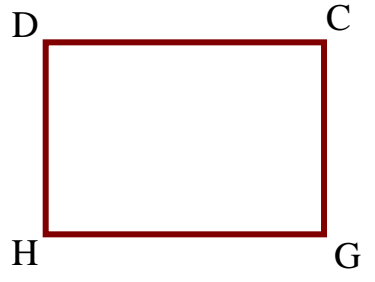

Back View

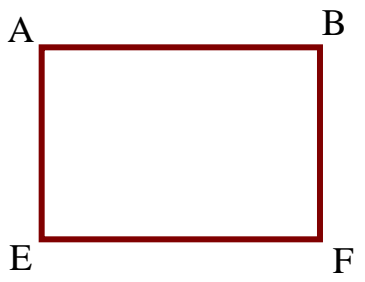

Front View



Left View



Right View

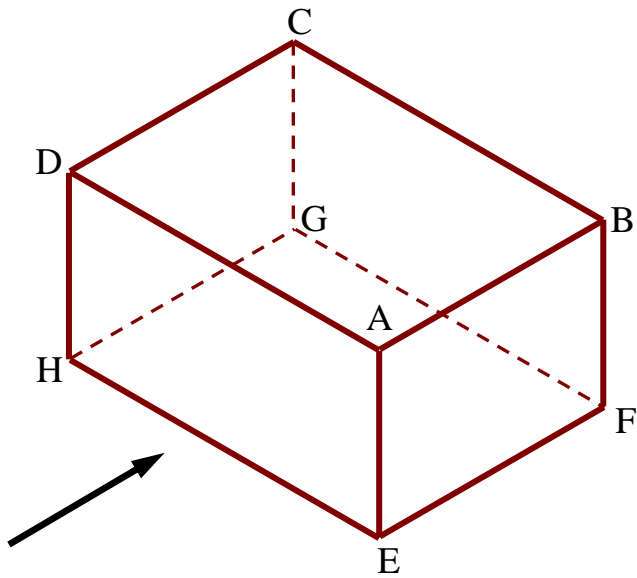

**Top View**

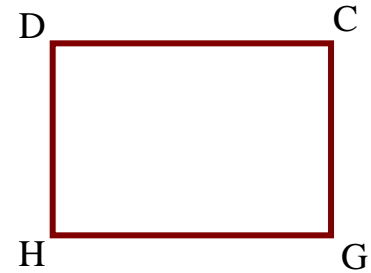

**Left View**

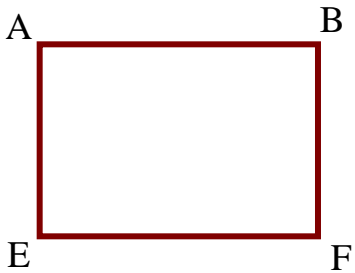

**Right View**



**Front View**



**Back View**

# TO PREPARE ISOMETRIC VIEW

- Box Method
- Co-ordinate or Offset Method
  - Offset Method
  - Four-centre method

# BOX METHOD

The isometric projection of solids like cube, square and rectangular prisms are drawn directly when their edges are parallel to the three isometric axes. The isometric projection of all other types of prisms and cylinders are drawn by enclosing them in a rectangular box. This method is called **Box method**.

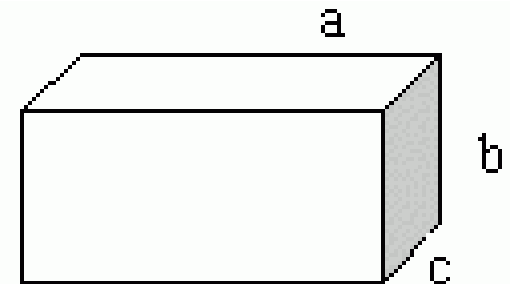
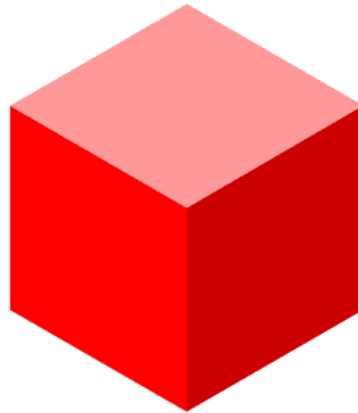
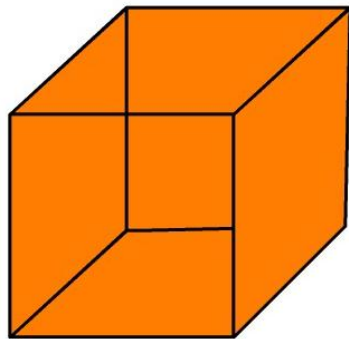

# CO-ORDINATE METHOD OR OFFSET METHOD

The isometric projections of pyramids and cones are generally drawn by Co-ordinate or Offset method

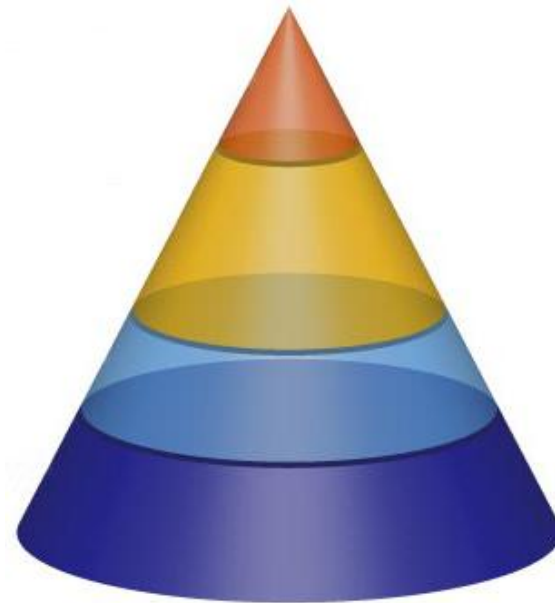
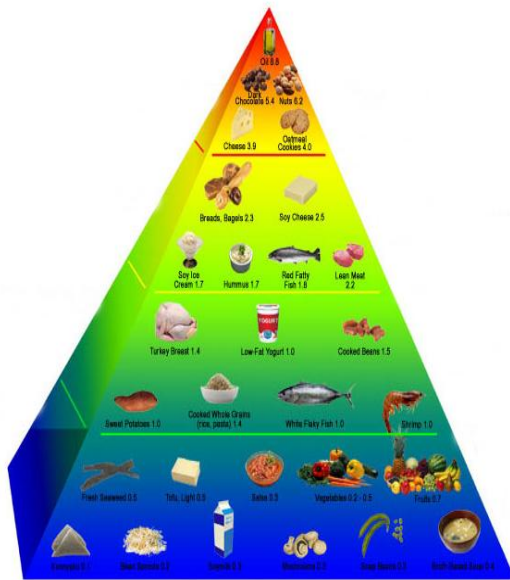

# EXAMPLES OF BOX METHOD

# ISOMETRIC VIEW OF A REGULAR PENTAGONAL PRISM (Resting on one of its faces on H.P)

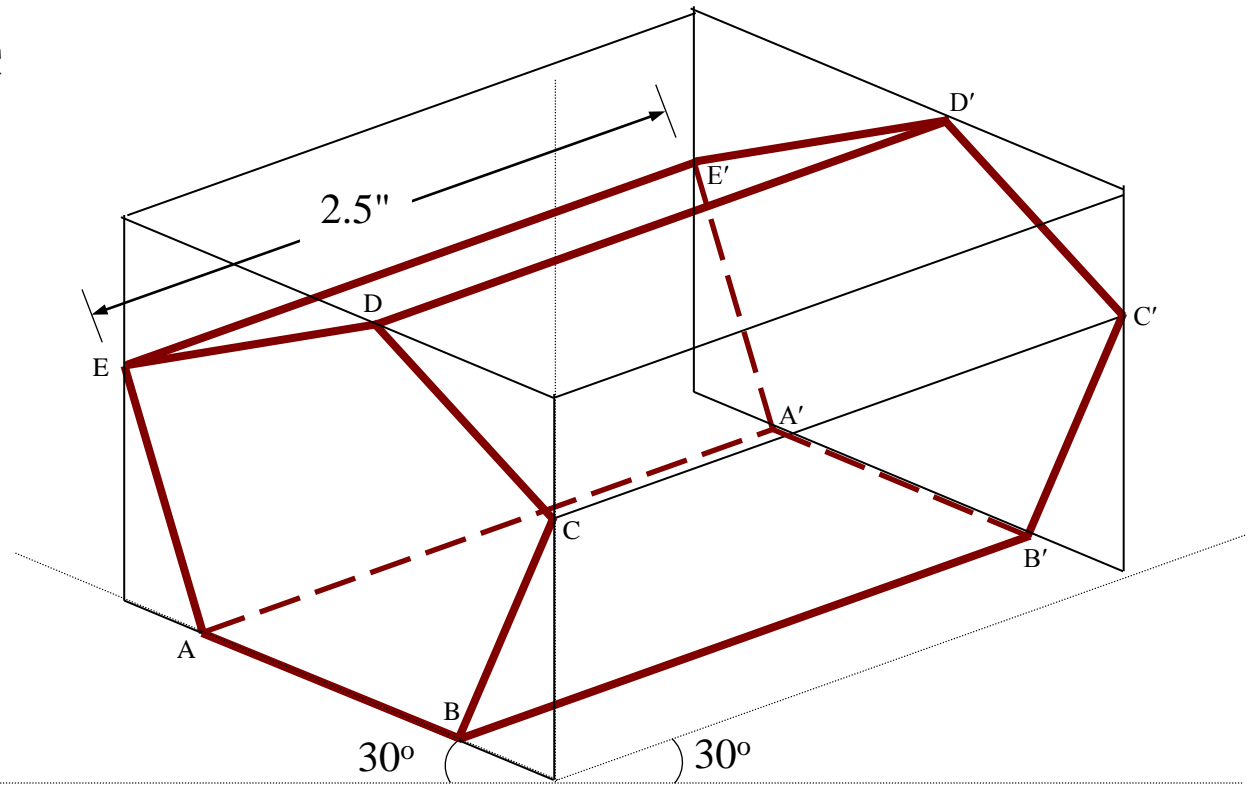
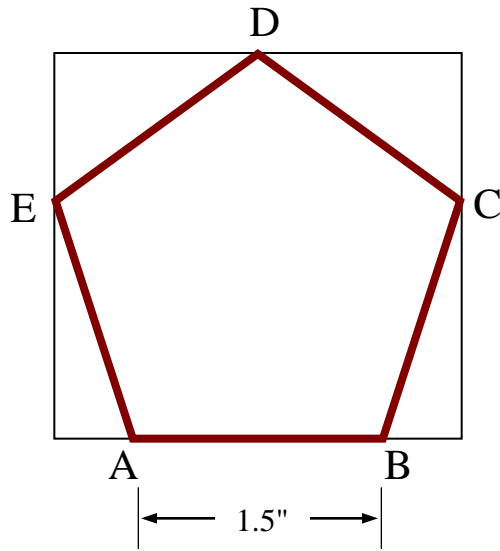

# ISOMETRIC VIEW OF A REGULAR HEXAGONAL PRISM (Resting on one of its faces on V.P)

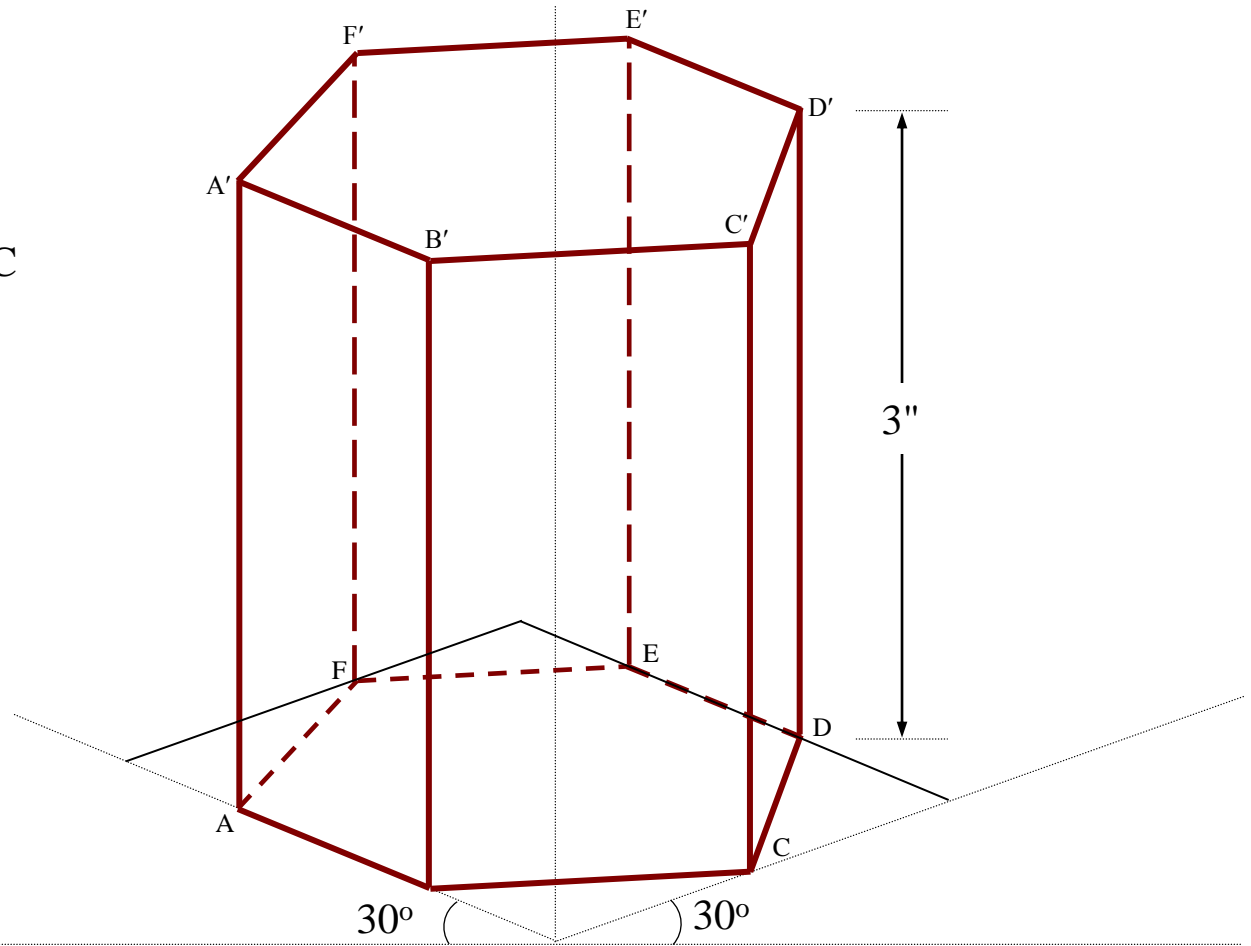
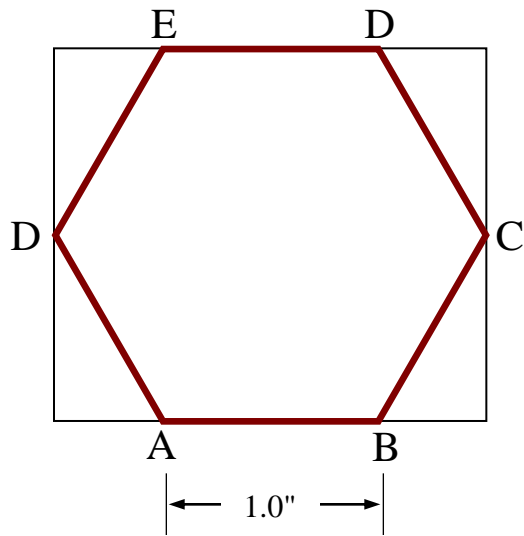

# EXAMPLES OF FOUR-CENTRE METHOD

# ISOMETRIC VIEW OF A CYLINDER (Lying on H.P)

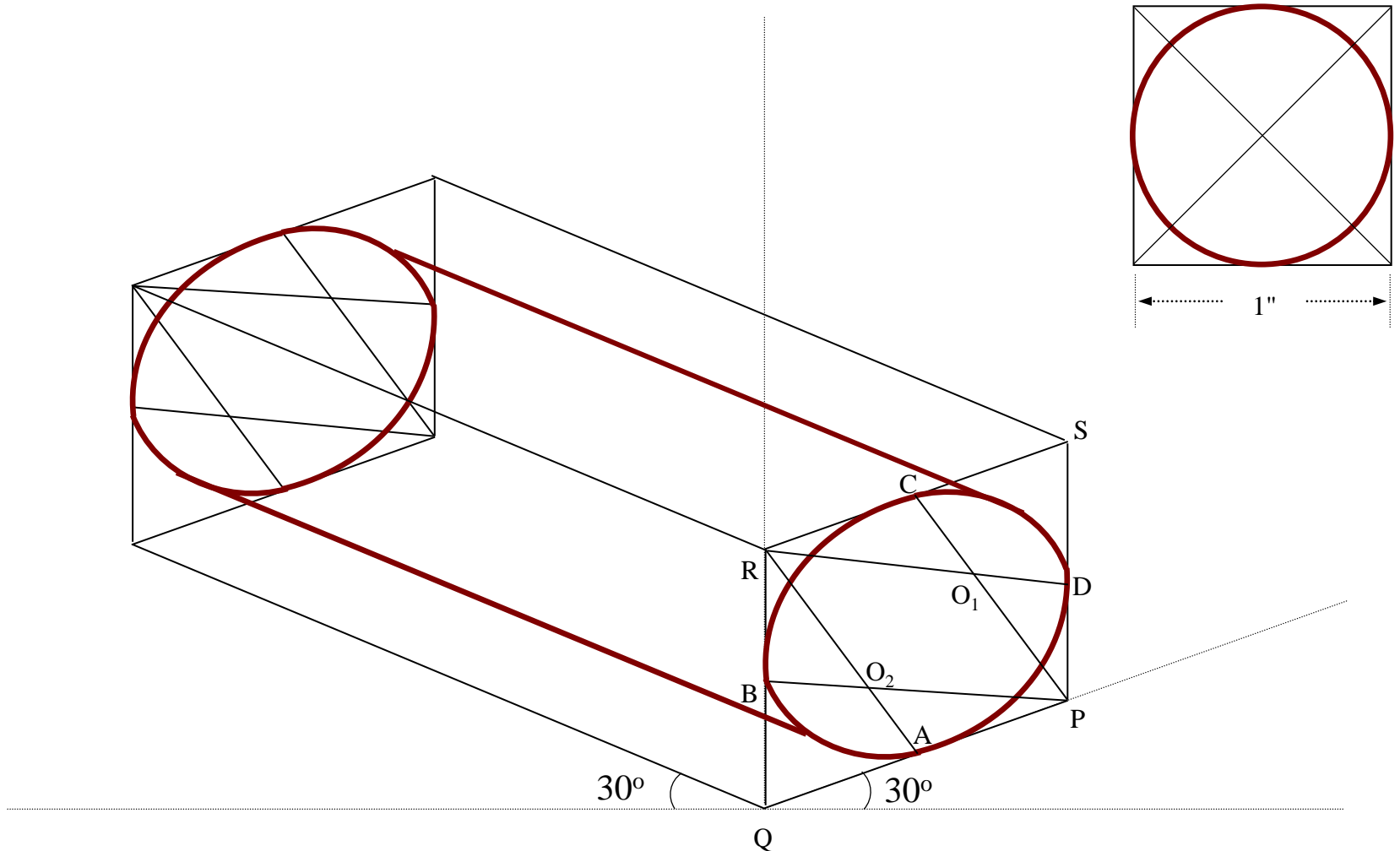

# ISOMETRIC VIEW OF A CYLINDER (Lying on V.P)

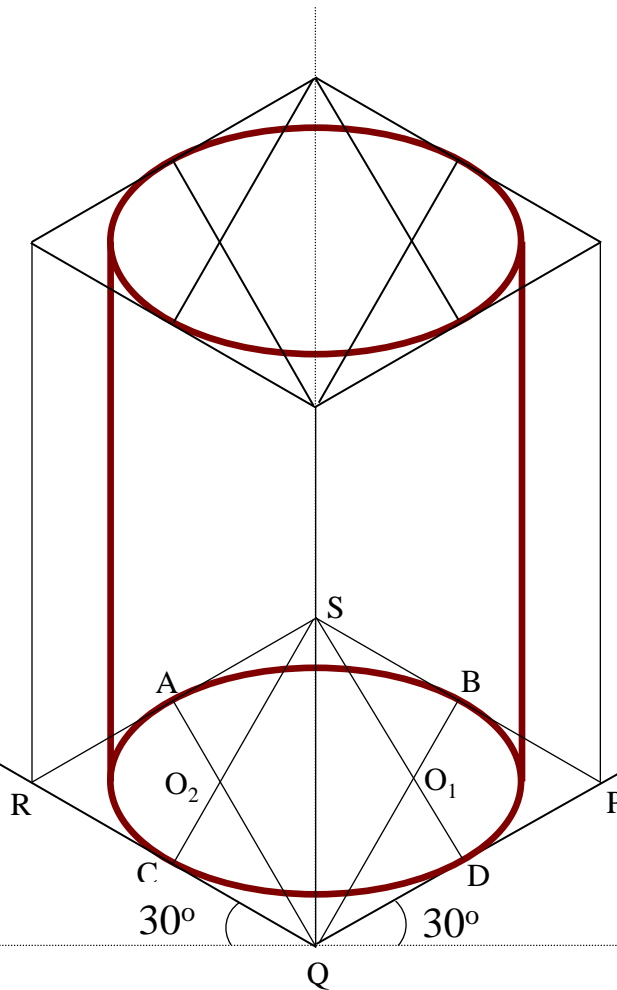
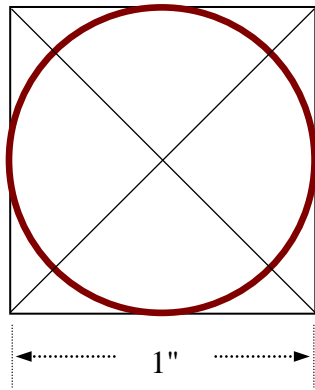

# **EXAMPLES OF CO-ORDINATE OR OFFSET METHOD**

The isometric view of a hexagonal pyramid of side of base 30 mm and height 75 mm, when it is resting on H.P such that an edge of the base is parallel to V.P

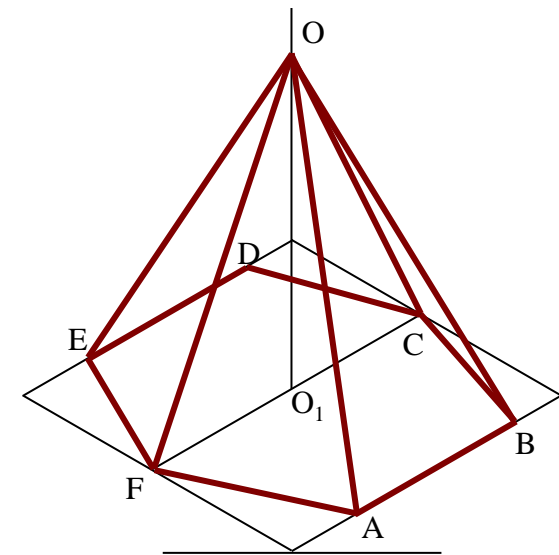
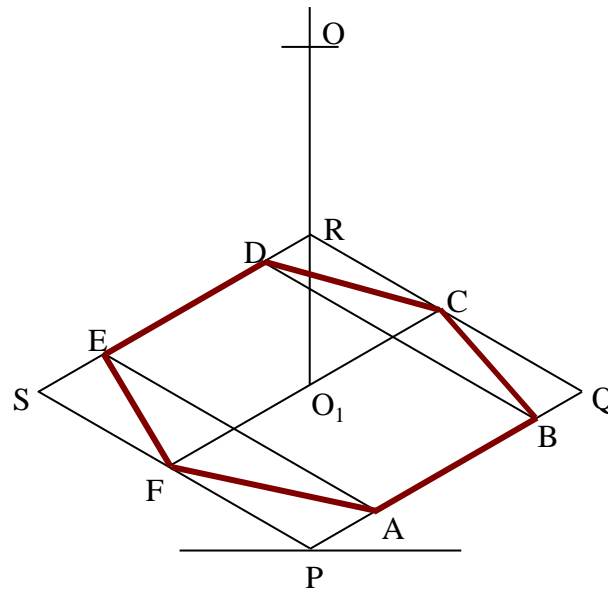
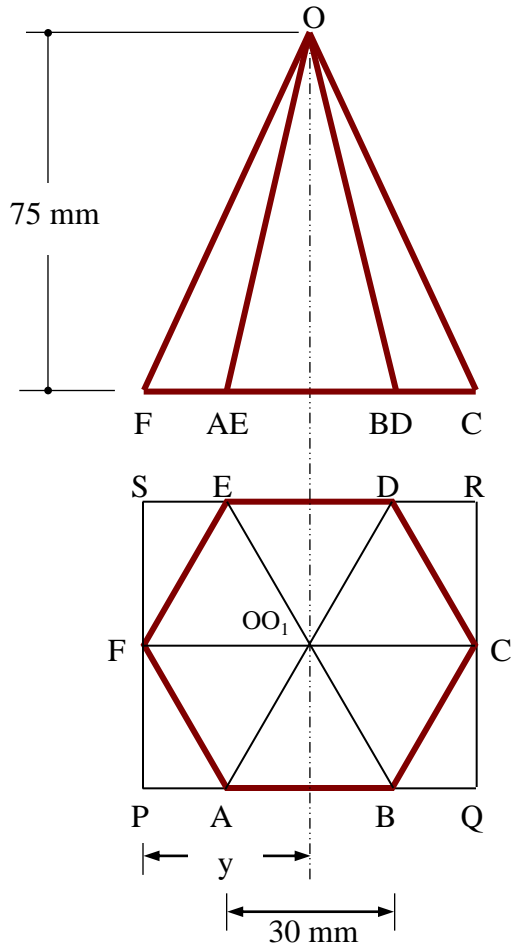

**Draw the isometric projection of a cone of base 40 mm diameter and height 58 mm when it rest with its base on H.P**

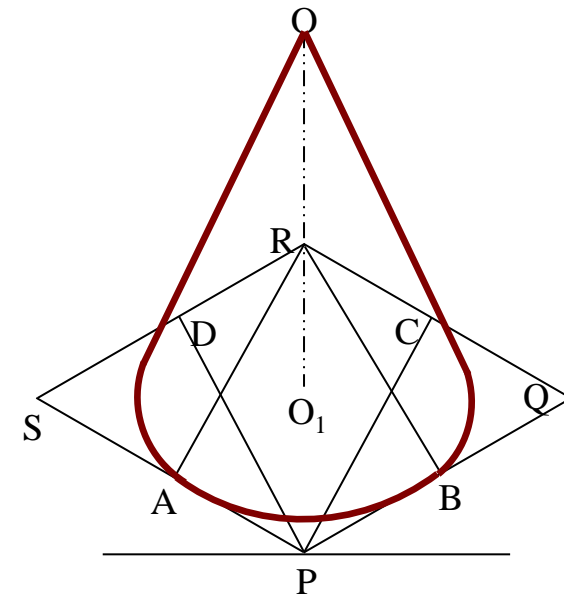
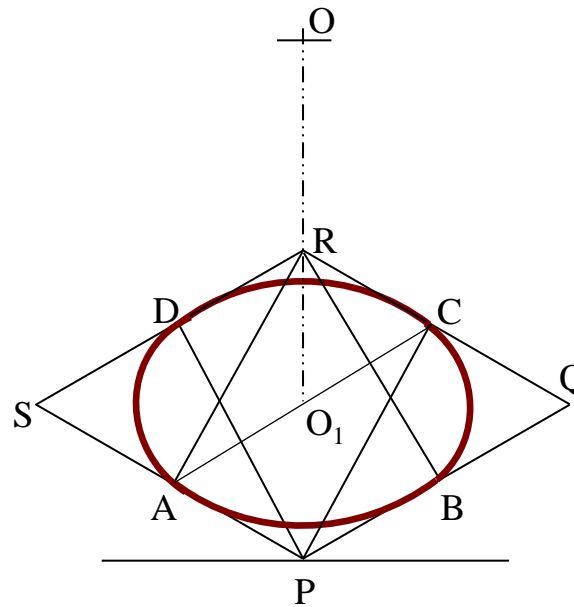
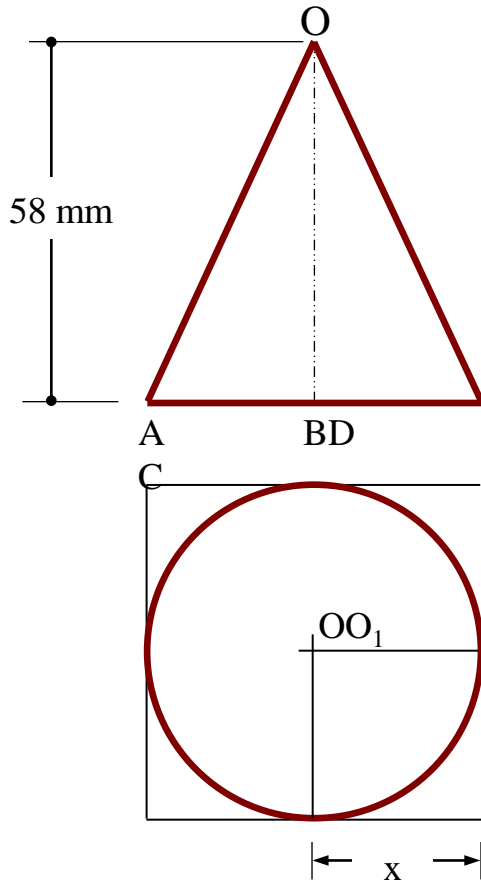

**DRAW FRONT, LEFT, RIGHT  
& TOP VIEW FROM A  
ISOMETRIC VIEW**

1

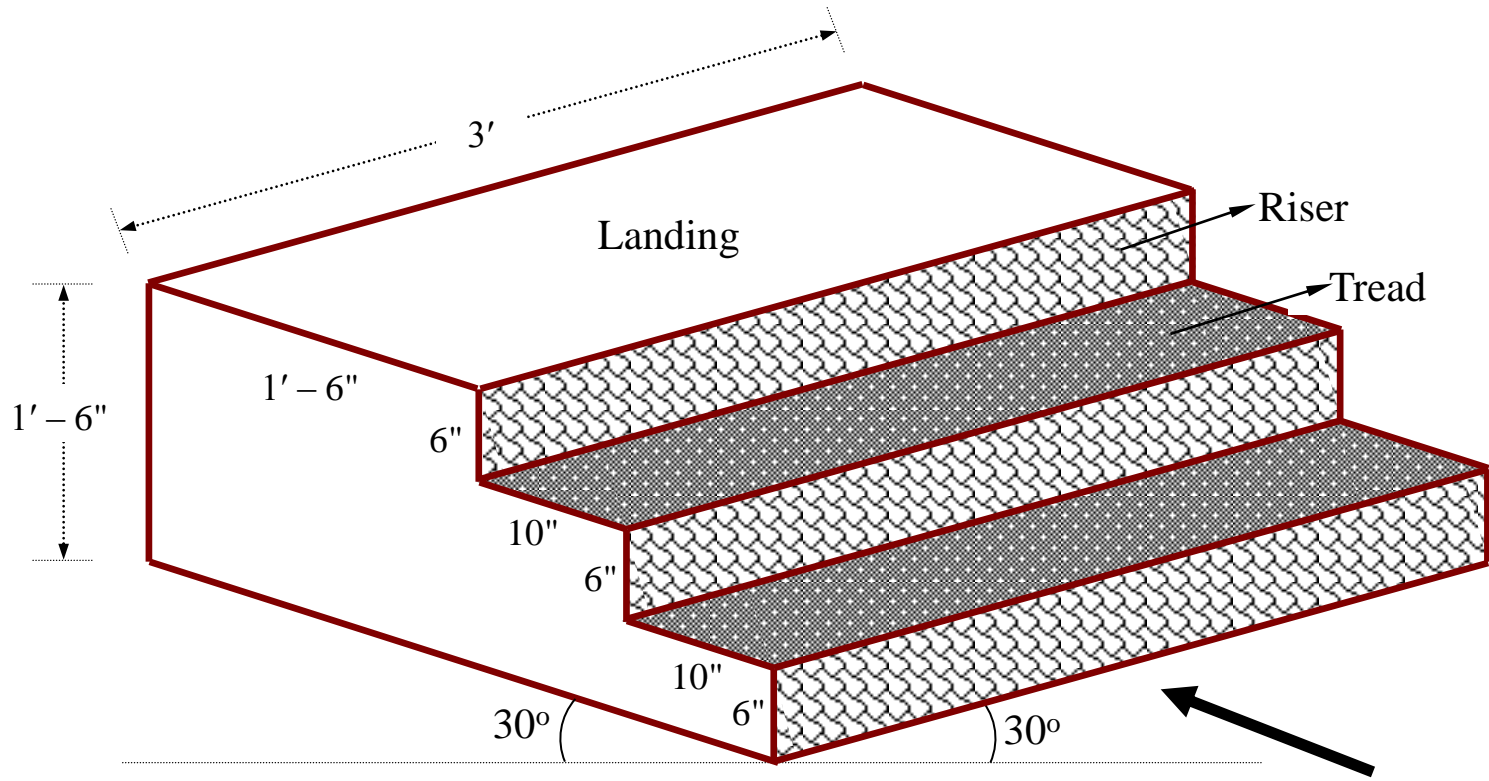

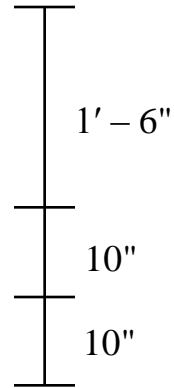
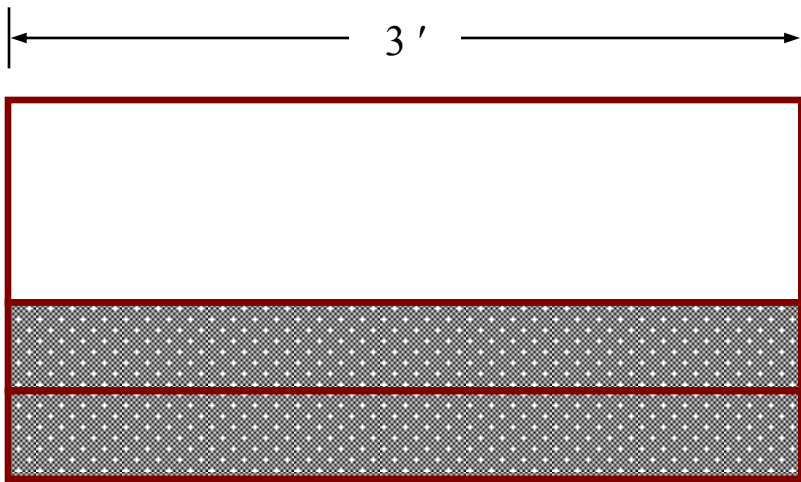

**TOP VIEW**

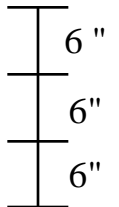
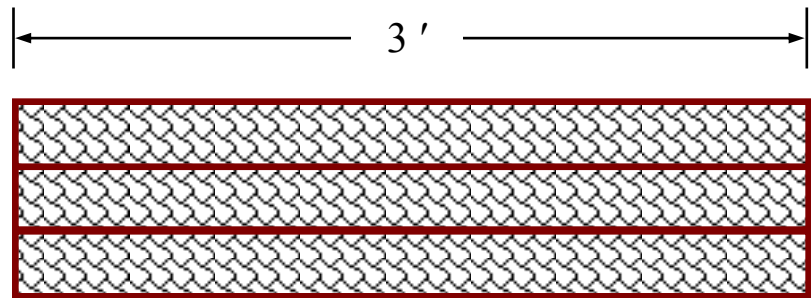

**FRONT VIEW**

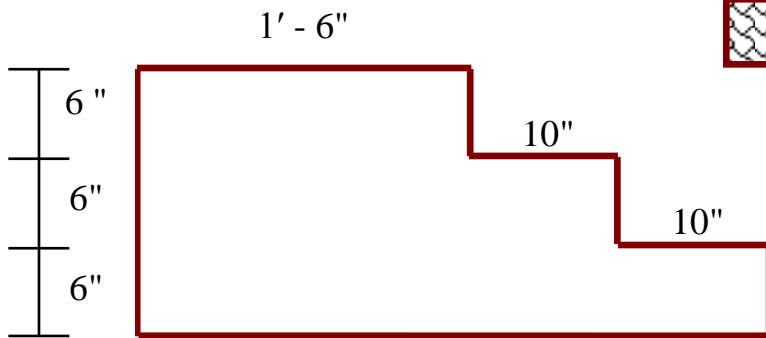

**LEFT VIEW**

2

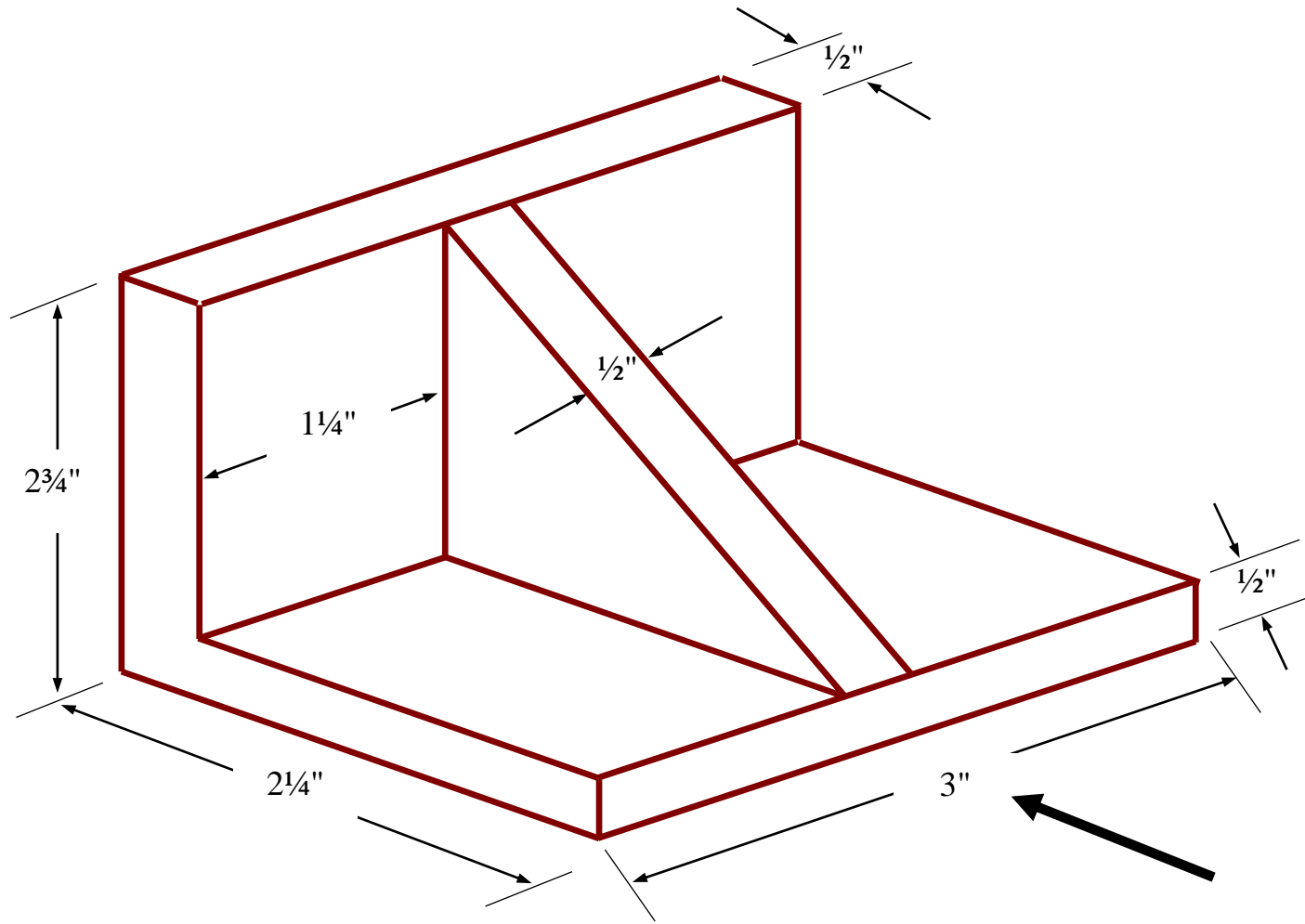

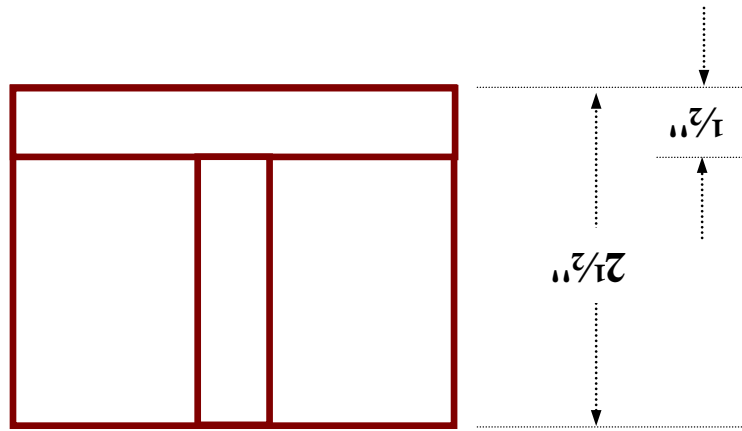

**TOP VIEW**

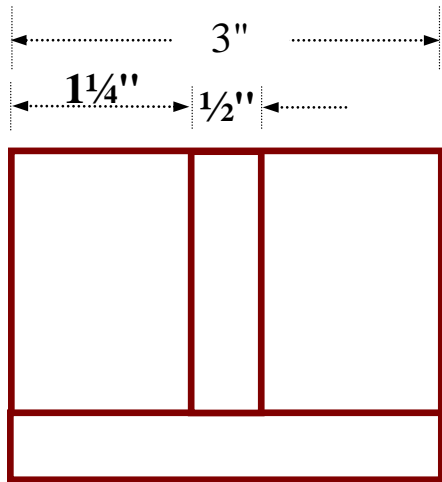

**FRONT VIEW**

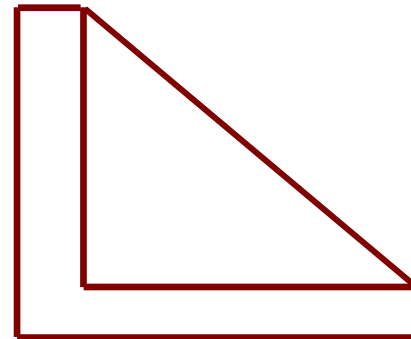
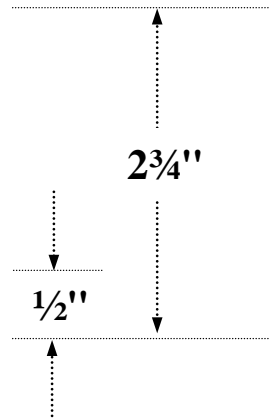

**LEFT VIEW**

3

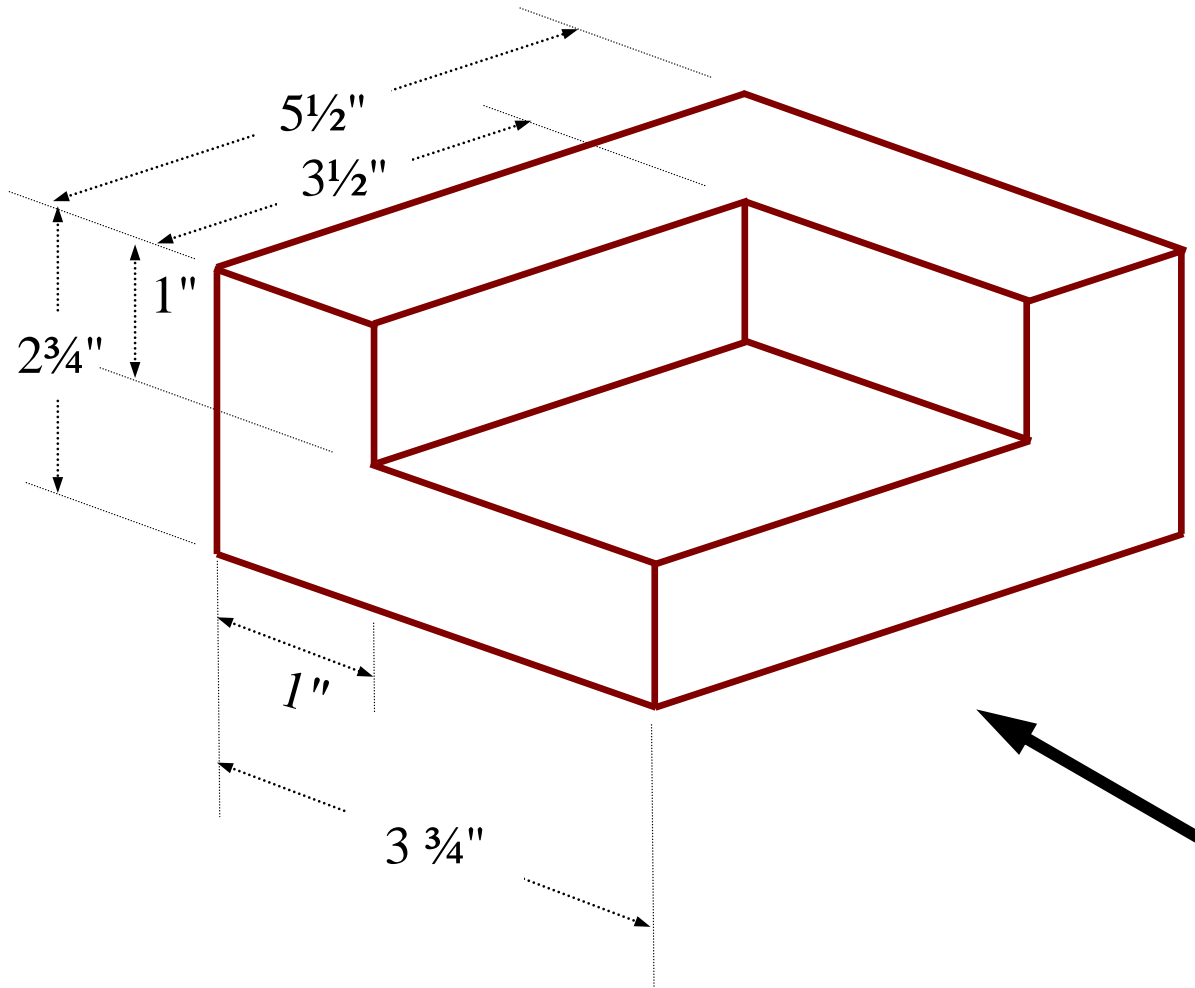

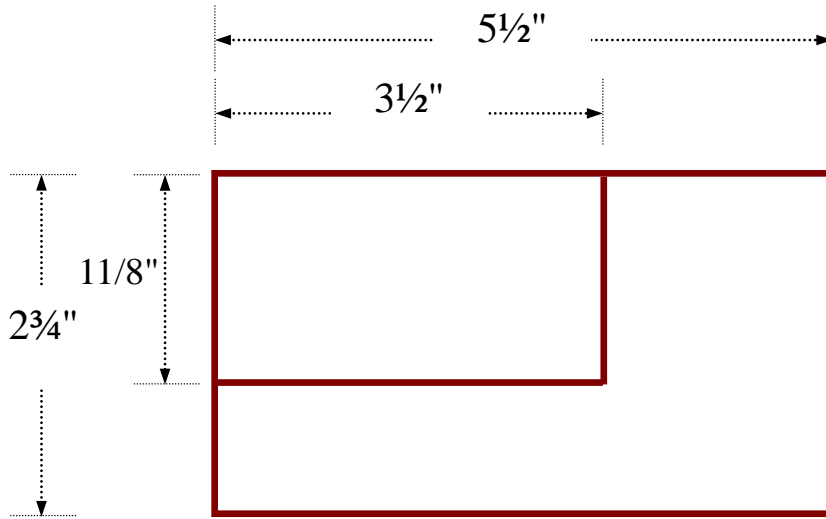

**FRONT VIEW**

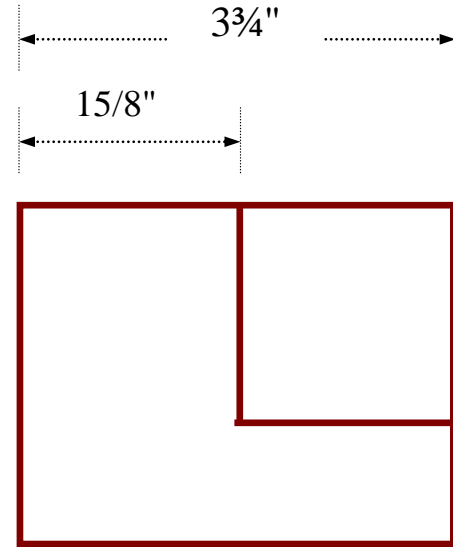

**LEFT VIEW**

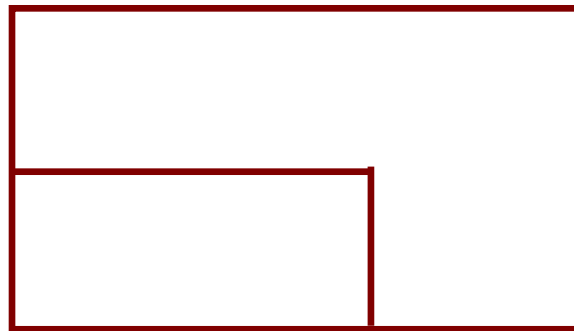

**TOP VIEW**

4

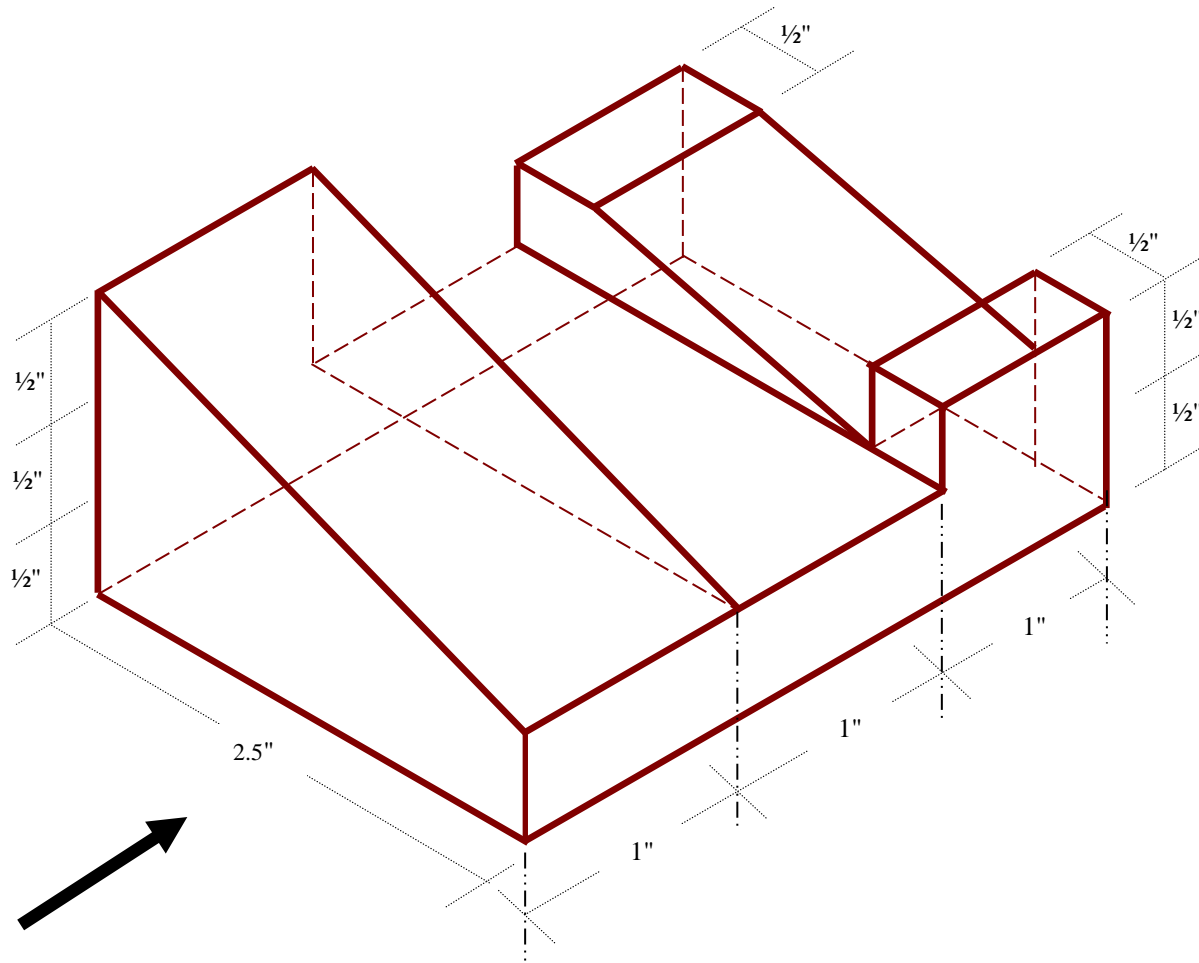

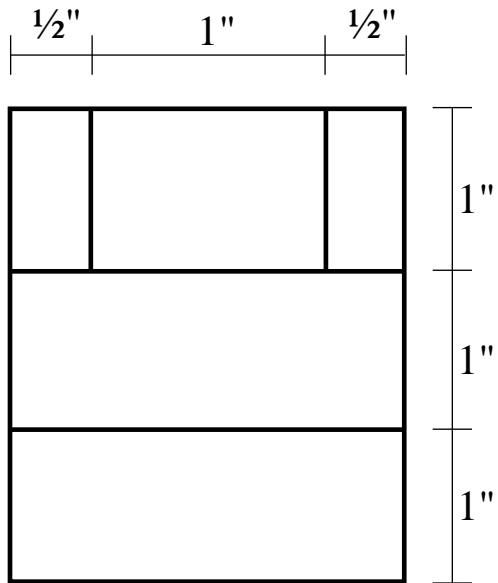

**TOP VIEW**

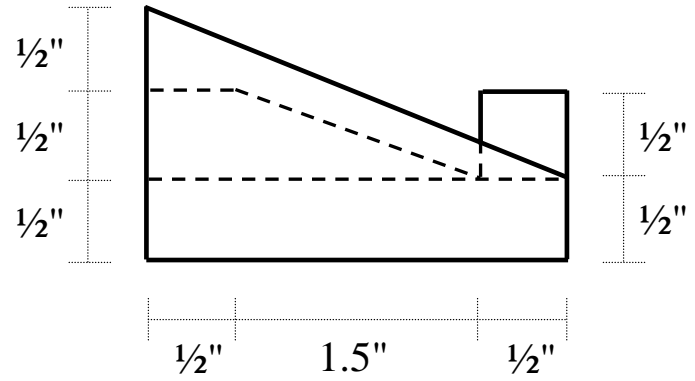

**FRONT VIEW**

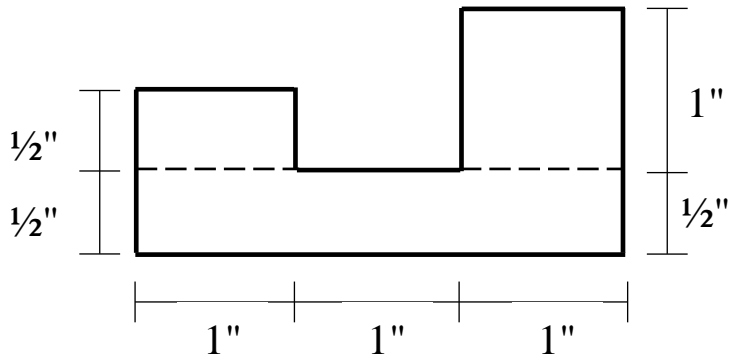

**LEFT VIEW**

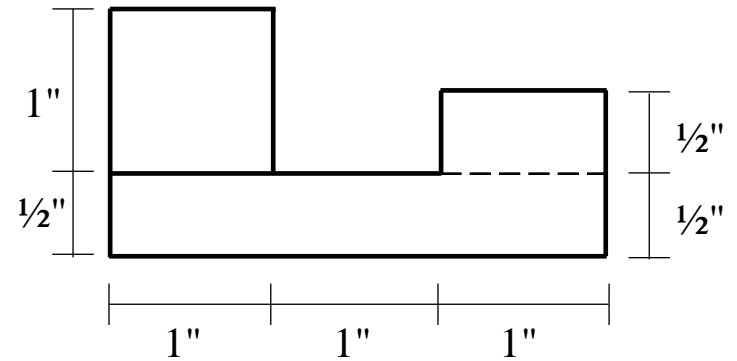

**RIGHT VIEW**

5

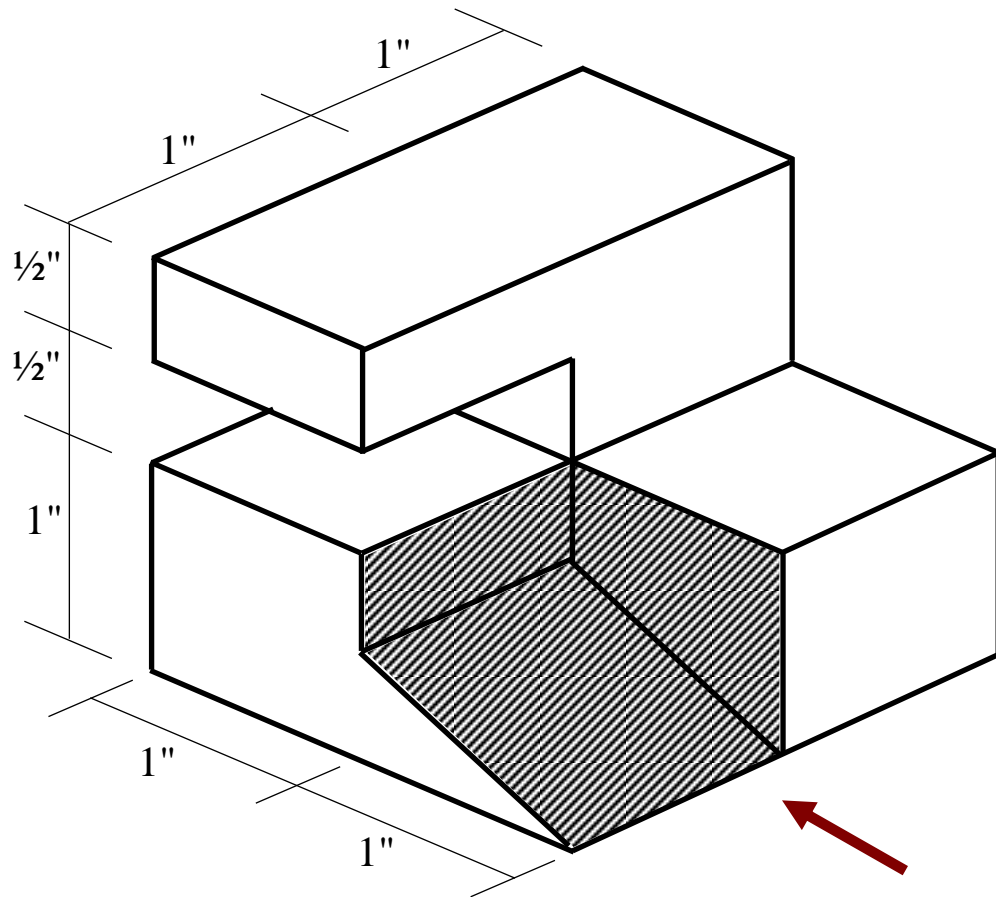

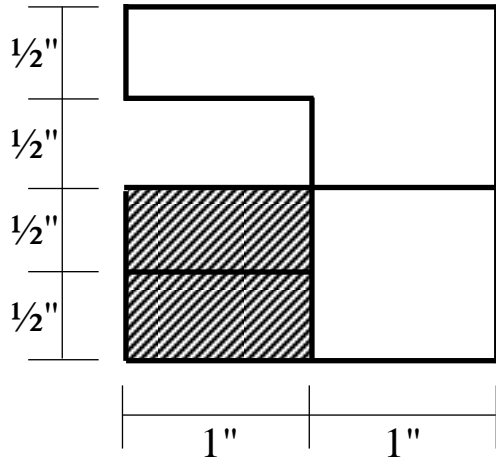

**FRONT VIEW**

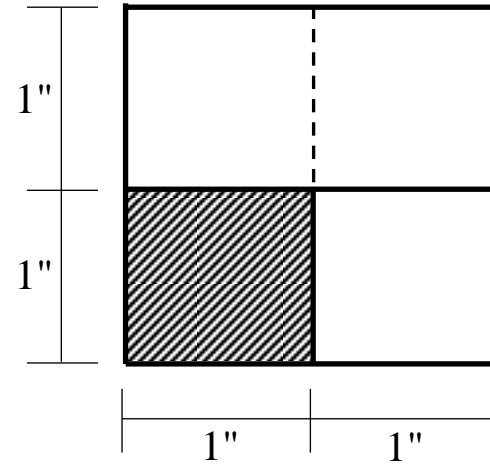

**TOP VIEW**

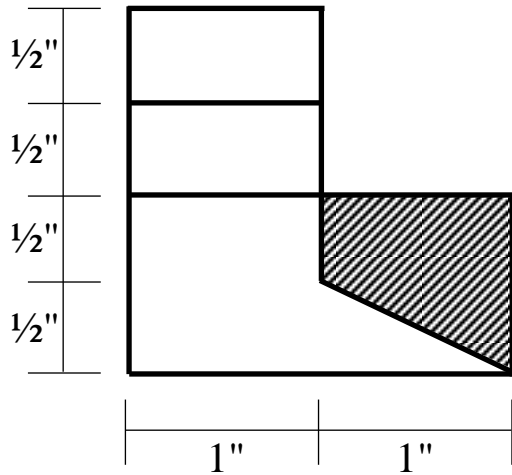

**LEFT VIEW**

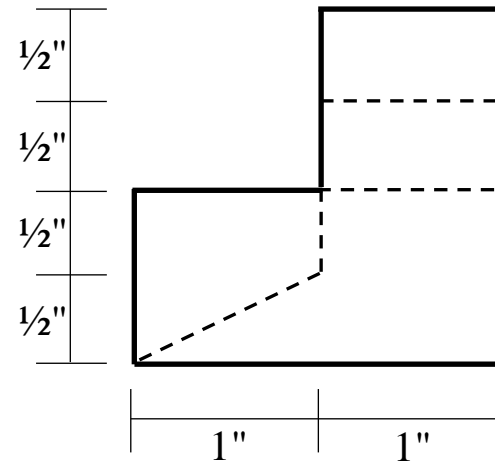

**RIGHT VIEW**

6

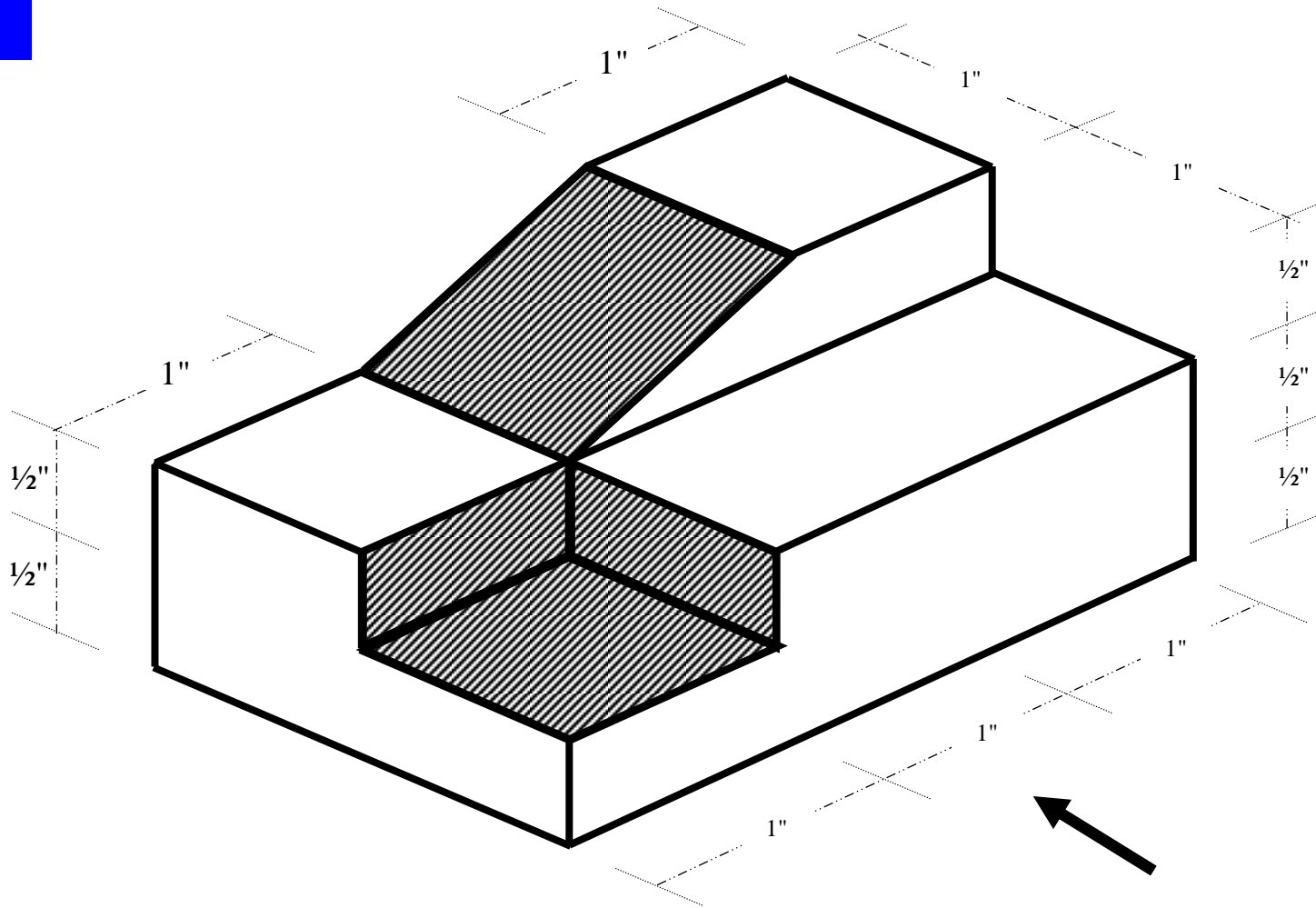

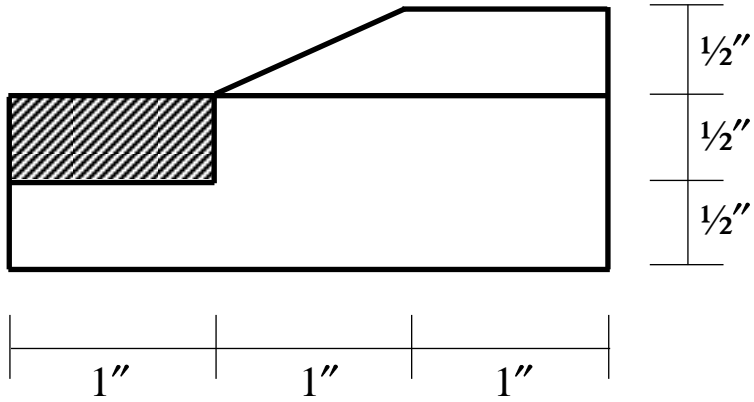

**FRONT VIEW**

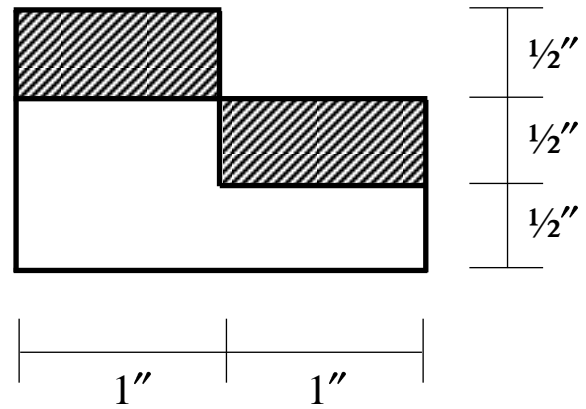

**LEFT VIEW**

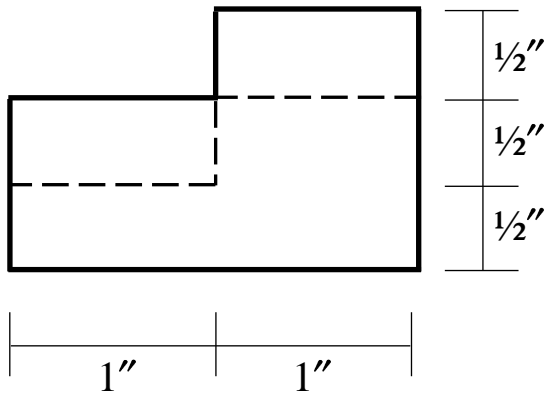

**RIGHT VIEW**

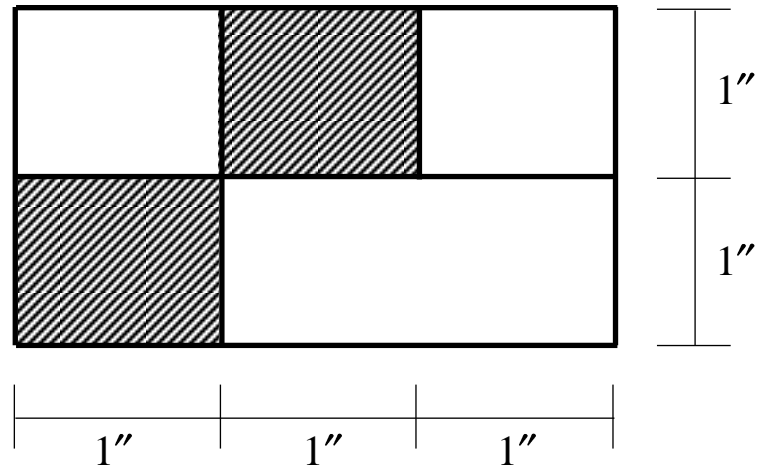

**TOP VIEW**

7

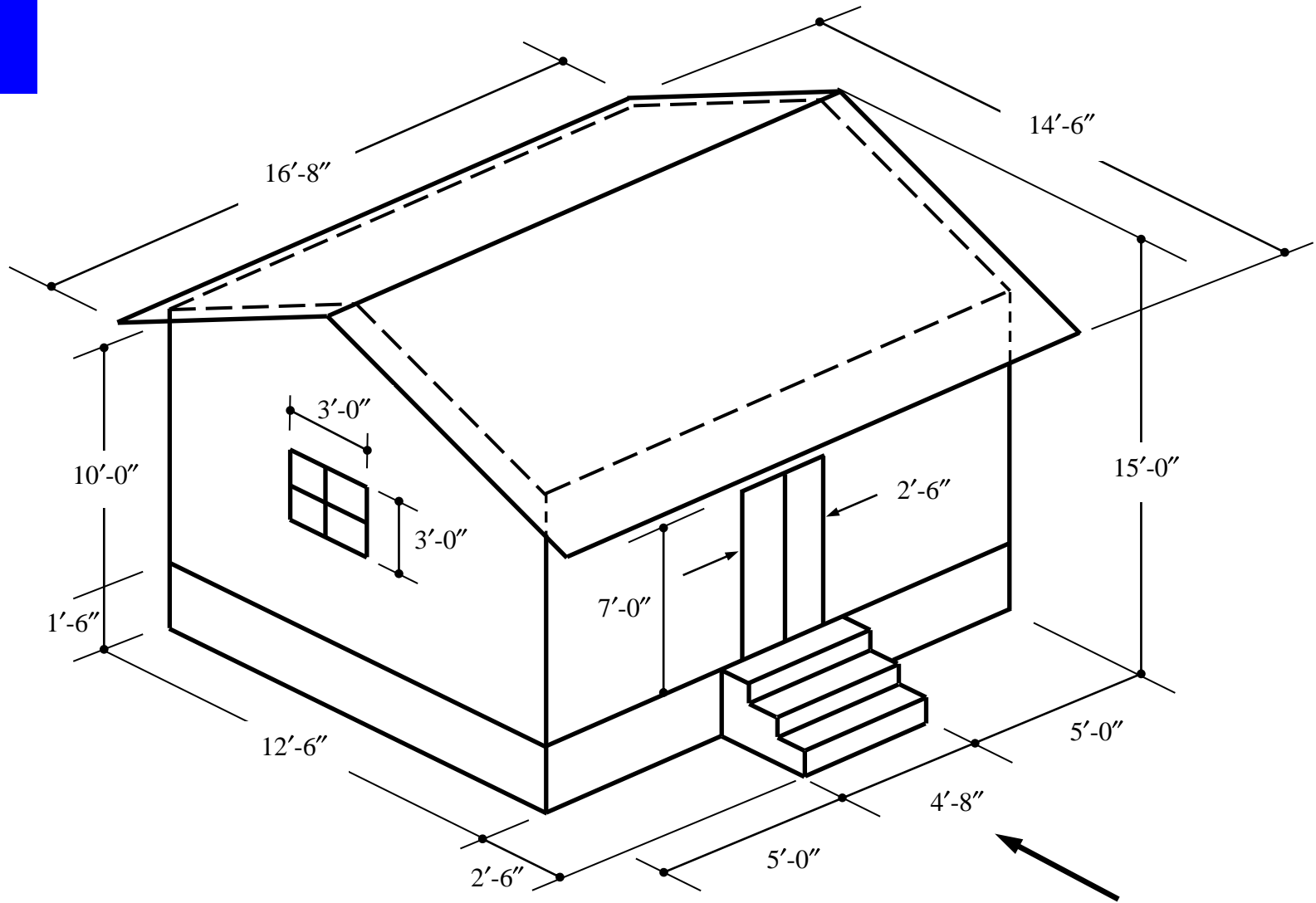

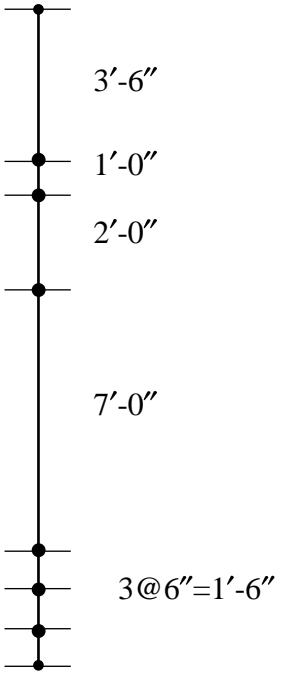
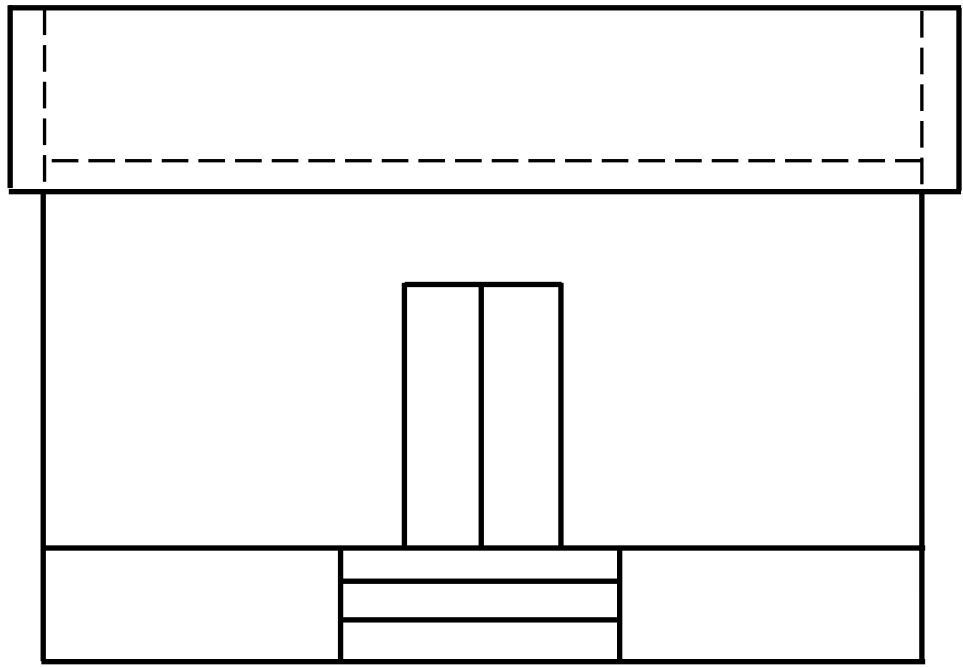
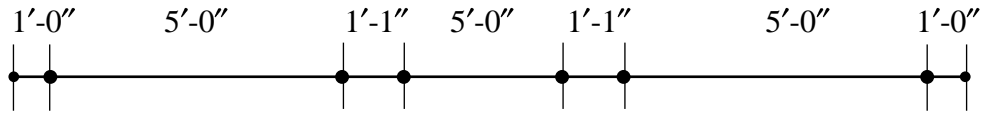

**FRONT VIEW**

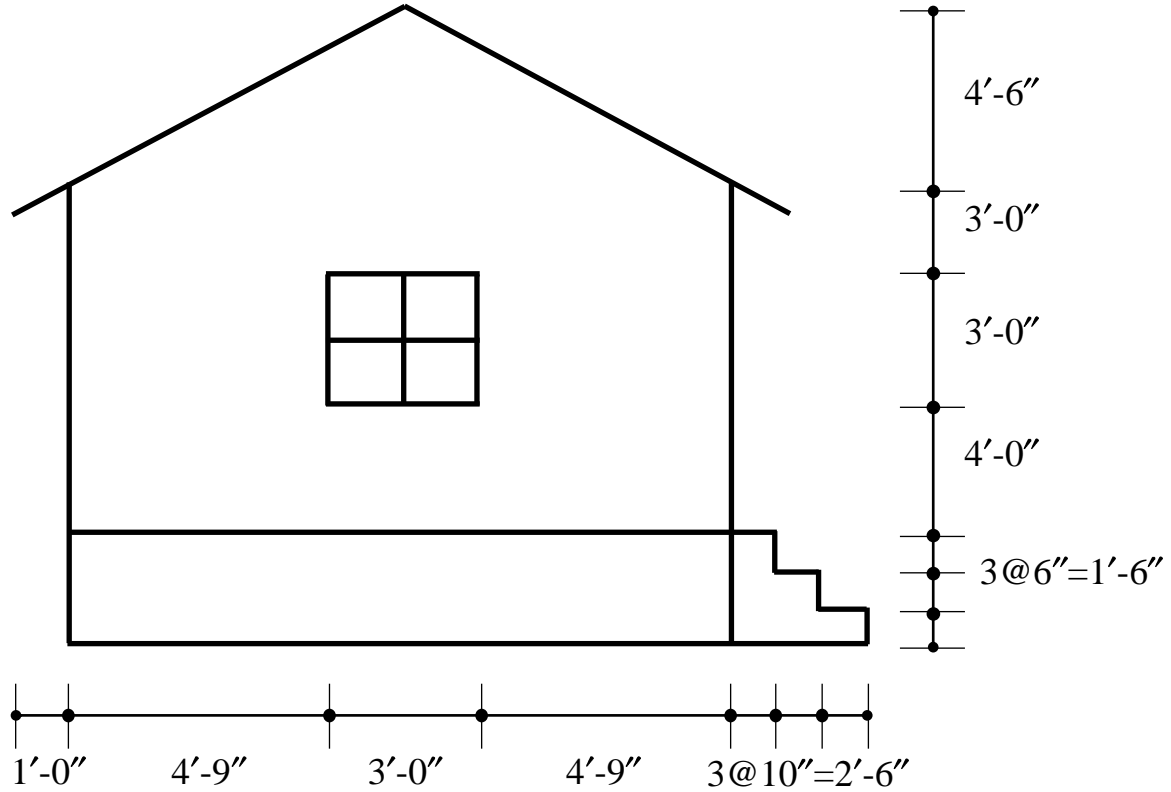

**LEFT VIEW**

Draw isometric view from the given orthographic projections.

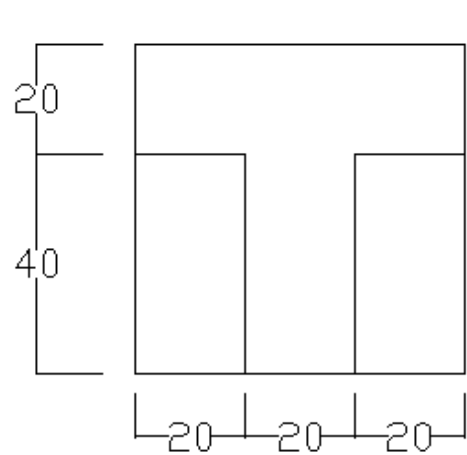

TOP VIEW

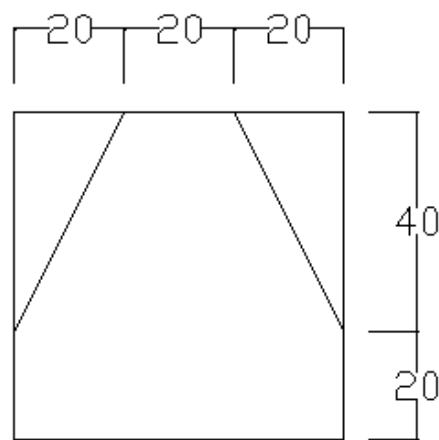

FRONT VIEW

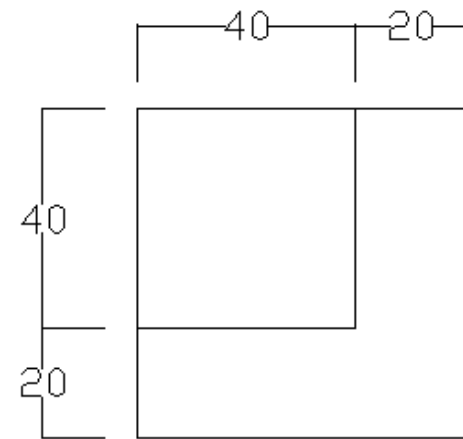

RIGHT SIDE VIEW

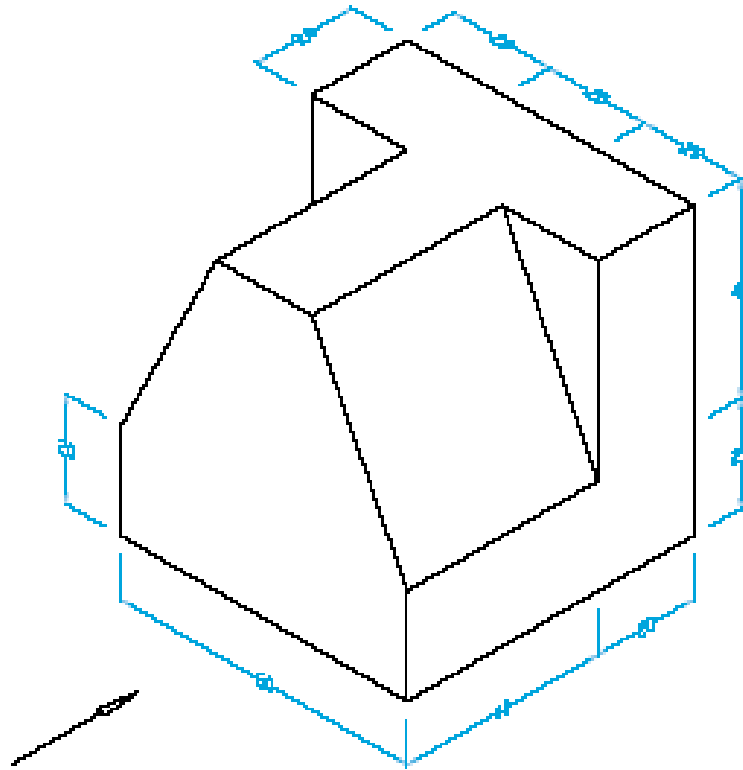

Isometric Projection

# Draw isometric view from the given orthographic projections.

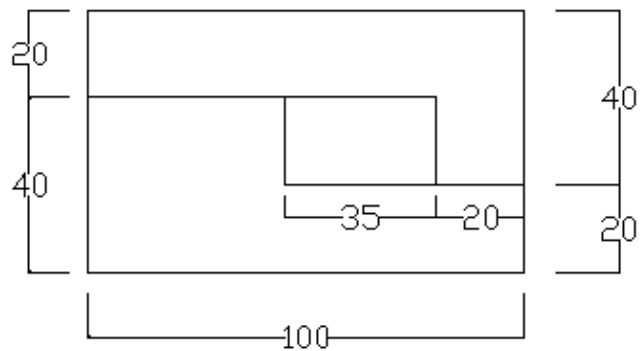

TOP VIEW

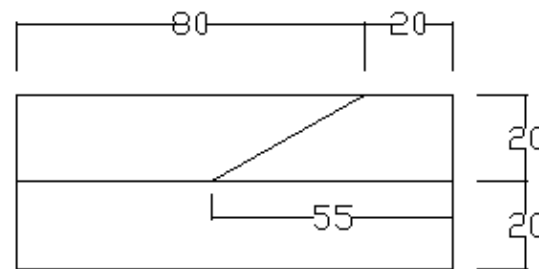

FRONT VIEW

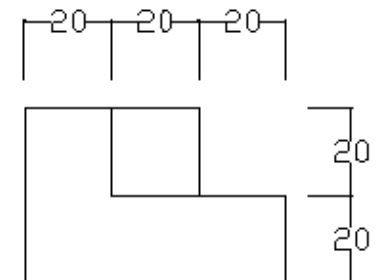

LEFT SIDE VIEW

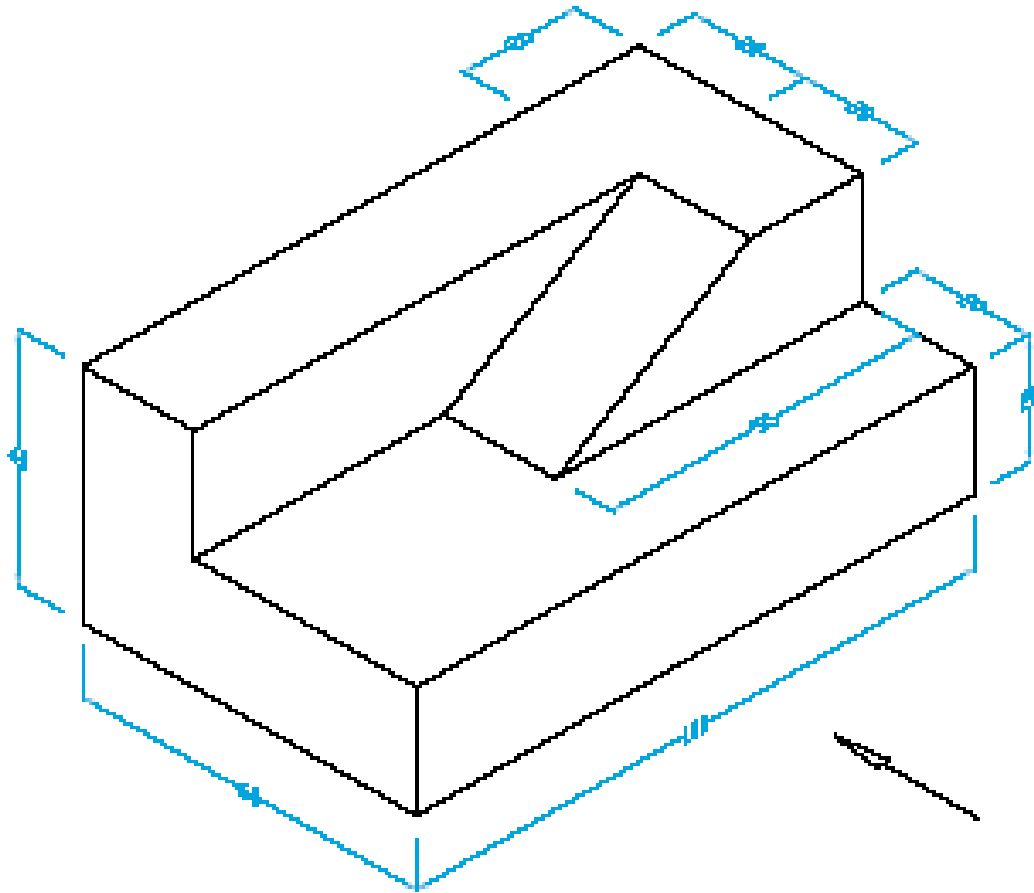

Isometric Projection

Draw isometric view from the given orthographic projections.

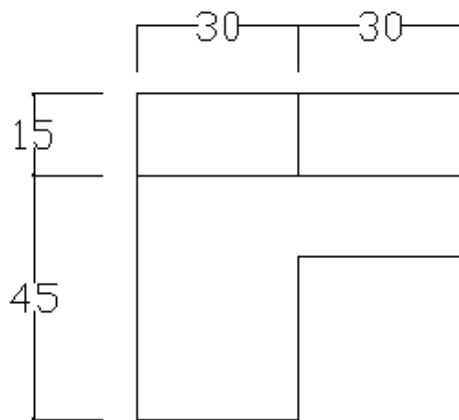

TOP VIEW

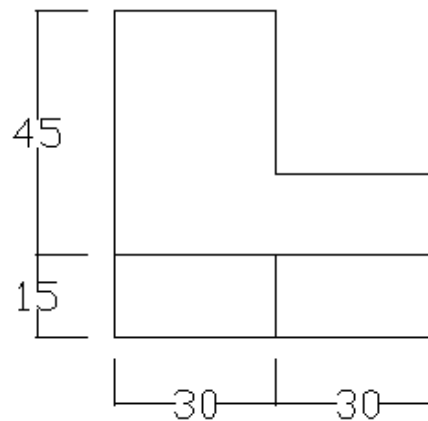

FRONT VIEW

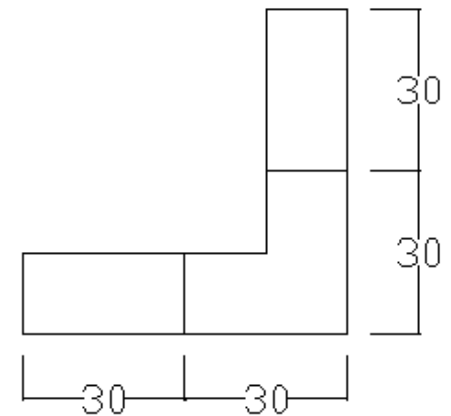

RIGHT SIDE VIEW

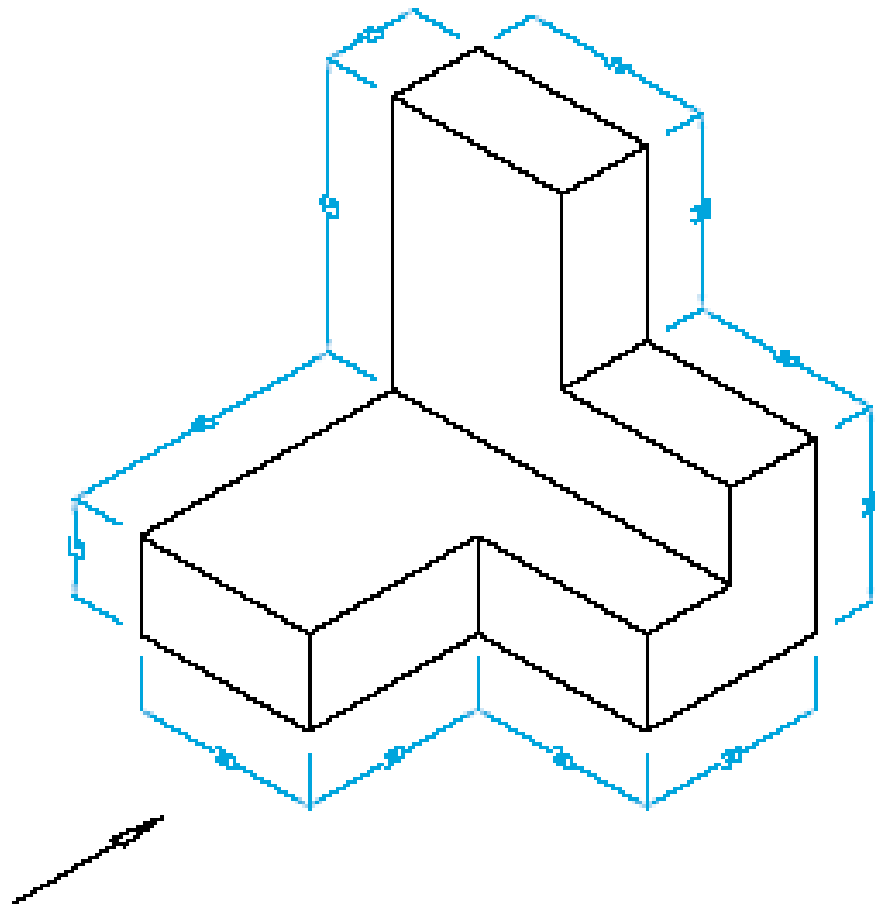

Isometric Projection

# Thank You

