

**CE103: Surveying (4 cr. Hr.)**  
by  
**Dr. Md. Jahangir Alam (1 cr. Hr.)**  
**Associate Professor**

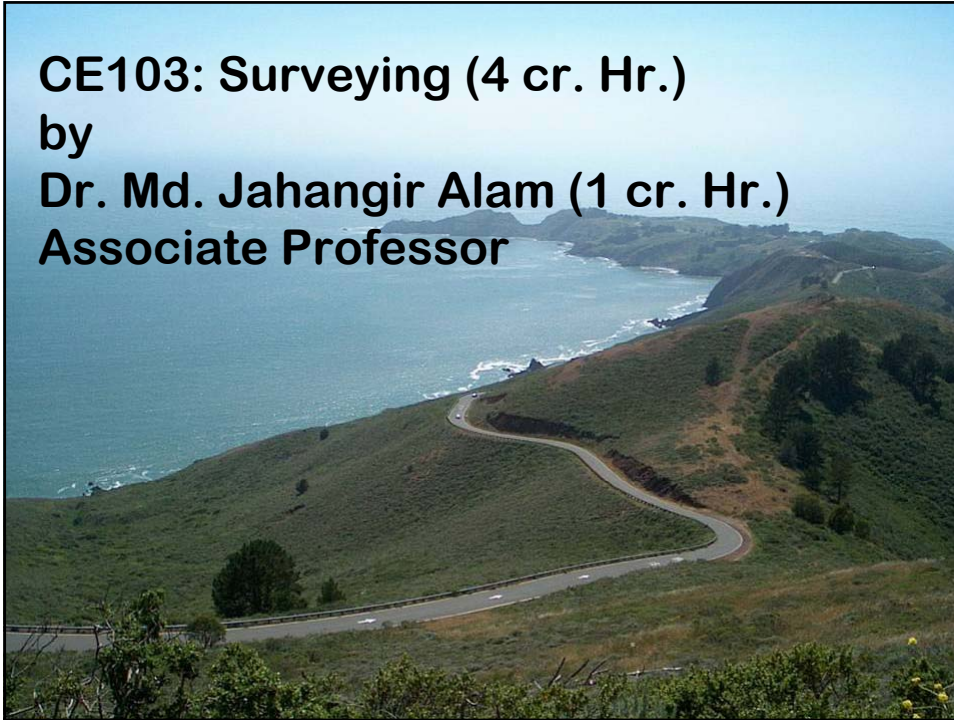

## CE103: Syllabus

- ◆ Curve Setting
  - Horizontal Curve
    - Circular Curve
    - Transition Curve
  - Vertical Curve
- ◆ Remote Sensing, GIS and GPS
- ◆ Reconnaissance and Project Surveying

Sunday, March 27, 2011

2

## Alignment Design

### 2. Horizontal curves

#### ➤ Simple curves

Continuous arcs of constant radius which achieve the necessary highway deflection without an entering or existing transition

#### ➤ Compound curves

A series of two or more simple curves possessing a common tangent at any points of meeting which turn in the same general direction and have their centers on the same side of the line. Any two adjacent areas must, of course, have different radii if they are to be compounded pair rather than a single curve



Sunday, March 27, 2011

3

## Alignment Design

### 2. Horizontal curves

#### ➤ Spiral curves

A parabolic type of curve used as a transition from a tangent to a circular curve, or from a circular to another circular of different radii

#### ➤ Reverse curves

S-curves, are similar to compound curves except that their centers are on opposite sides of the line and their direction of turning is opposite to each other

#### ➤ Broken-back curves

Two closely spaced simple curves with deflection in the same direction and a short intervening tangent



Sunday, March 27, 2011

4

The diagram shows four types of curves on a blue background. On the left, there is a vertical decorative bar with a textured gold top half and a solid gold bottom half, containing a black silhouette of a key. The curves are: 1. 'Simple curve' (white arc), 2. 'Broken-back curves' (red arc with a sharp inward kink), 3. 'Compound curve' (red arc with a smooth inward kink), and 4. 'Reverse curve' (yellow S-shaped curve). Each curve has white lines pointing to its label.

Simple curve

Broken-back curves

Compound curve

Reverse curve

Sunday, March 27, 2011

5

The diagram shows a red spiral curve on a blue background. On the left, there is a vertical decorative bar with a textured gold top half and a solid gold bottom half, containing a black silhouette of a key. The spiral starts from the bottom left and winds inward in a clockwise direction.

Spiral

Sunday, March 27, 2011

6

## Alignment Design

### 3. Factors influencing the location and configuration of horizontal alignment

#### ➤ Physical controls

Topography, watercourses, geophysical conditions, land use, and man-made features

#### ➤ Environment considerations

Affect on adjacent land use, community impacts, ecologically sensitive areas

#### ➤ Economics

Construction costs, right-of-way costs, utility impacts, operating and maintenance costs

#### ➤ Safety

Sight distance, consistency of alignment, human factor considerations

#### ➤ Highway classification and design policies

Functional classification, level of service, design speed, design standards

Sunday, March 27, 2011

7

## Alignment Design

### 4. Design criteria

#### ➤ Design speed: principal factor

#### ➤ Consistency: consistent and as directional as possible

- preferable to long, flat curves
- no circular curves of different radii placed end to end;
- no short tangents placed between two curves;
- Long, flat curves for small changes in direction
- no sudden changes from flat to sharp curves
- no long tangents followed by sharp curves

#### ➤ Length of curves:

#### ➤ Adjacent curves:

Sunday, March 27, 2011

8

## Alignment Design

### Notations in reading alignment drawings

- PC: point of curve
- PT: point of tangent
- TS: tangent to spiral
- SC: spiral to circular curve
- CS: circular curve to spiral
- ST: spiral to tangent
- VPC: vertical point of curvature—the point at which a tangent grade ends and the vertical curve begins.
- VPI: vertical point of intersection—the point where the extension of two tangent grades intersect
- VPT: vertical point of tangency—the point at which the vertical curve ends and the tangent grade begins

Sunday, March 27, 2011

9

## Elements of Circular Curve

Mid Ordinate, M  
 External Distance Or Apex Distance, E  
 Deflection Angle,  $\Delta$   
 Long Chord, XZ  
 Normal Chord,  
 Length of Curve, L  
 Point of Intersection, PI  
 Point of Curve, PC  
 Point of Tangent, PT  
 Tangent Distance, T  
 Radius of Curvature, R

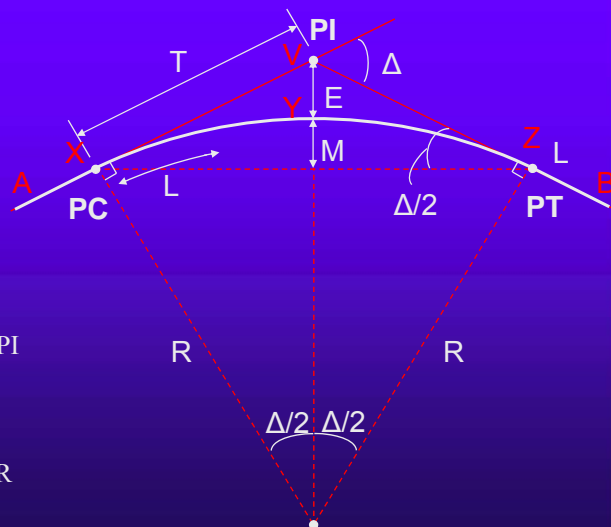

Sunday, March 27, 2011

10



### Degree of Curvature (D)

Angle (in Degree) subtended by 100 ft length of arc in the centre of the arc is defined as degree of curvature

$$\frac{2\pi R}{100} = \frac{360}{D}$$

$$\frac{2\pi R}{360} = \frac{100}{D}$$

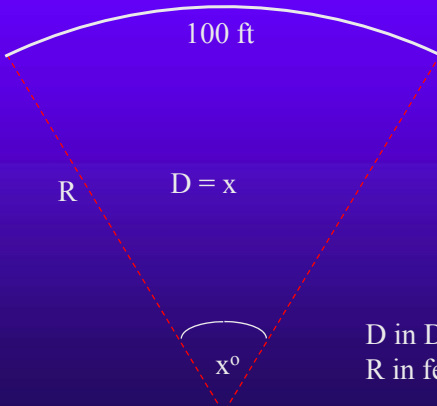
$$R = \frac{5730}{D}$$

D in Degree  
R in feet

Sunday, March 27, 2011 11



### Metric Degree of Curvature (D)

Angle (in Degree) subtended by 20 m length of arc in the centre of the arc is defined as metric degree of curvature

$$\frac{2\pi R}{360} = \frac{20}{D}$$

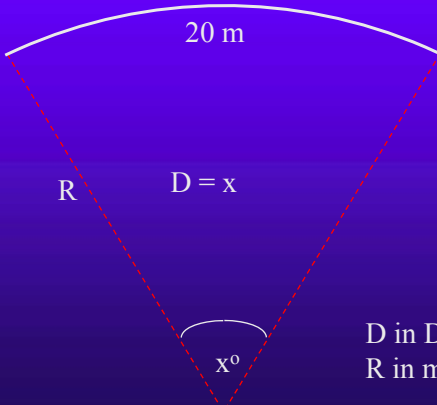
$$R = \frac{1146}{D}$$

D in Degree  
R in meters

Sunday, March 27, 2011 12

## Elements of Circular Curve

$$T = R \tan \frac{\Delta}{2}$$

$$L = \frac{\pi}{180} R \Delta = \frac{100 \Delta}{D}$$

$$D = \frac{100 \left( \frac{180}{\pi} \right)}{R} = \frac{18,000}{\pi R}$$

Sunday, March 27, 2011 13

## Elements of Circular Curve

$$E = R \left( \frac{1}{\cos \frac{\Delta}{2}} - 1 \right)$$

$$M = R \left( 1 - \cos \frac{\Delta}{2} \right)$$

Sunday, March 27, 2011 14

## Setting Out Circular Curve

- ◆ Linear method
  - By ordinates or offsets from long chord
  - By offsets from the tangents
    - Radial offset
    - Perpendicular offset
  - By offset from successive chords produced
- ◆ Angular method
  - Rankine's method of tangential/deflection angle
  - Two theodolite method

Sunday, March 27, 2011

Details later

15



Thodolite



Staff



Level



Total Station



Sunday, March 27, 2011

16

## Ordinate from long chord

$x = \text{known}$   
 $y = ?$

$AC = R \sin \Delta / 2$   
 $FD = BC = AC - AB$   
 $= R \sin \Delta / 2 - x$

$OC = R \cos \Delta / 2$   
 $OD = \sqrt{R^2 - FD^2}$

$OD = \sqrt{R^2 - (R \sin \Delta / 2 - x)^2}$   
 $y = OD - OC$

Sunday, March 27, 2011 17

## Radial offset from tangent

$x = \text{known}$   
 $y = ?$

$\Delta OAD \Rightarrow \Rightarrow$   
 $(R + y)^2 = x^2 + R^2$   
 $y = \sqrt{x^2 + R^2} - R$

Sunday, March 27, 2011 18

### Perpendicular offset from tangent

$x = \text{known}$   
 $y = ?$

$\triangle OBF \Rightarrow$   
 $(R-y)^2 + x^2 = R^2$   
 $y = R - \sqrt{R^2 - x^2}$

Sunday, March 27, 2011

19

### offset from chords produced

$c_1 = \text{known}$   
 $y_1 = ?$

$y_1 = c_1 \delta_1$   
 $c_1 = R(2\delta_1)$   
 $y_1 = c_1^2 / 2R$

$y_1 = \frac{c_1^2}{2R}$

Sunday, March 27, 2011

20

### Rankine's method of tangential deflection angle

$c_1 = \text{known}$   
 $\delta_1, \delta_2, \delta_3 = ?$

$c_1 = R(2\delta_1)$

Sunday, March 27, 2011 21

### Two theodolite method

Locate F1, F2, F3 for  
 $\delta_1, \delta_2, \delta_3$

Sunday, March 27, 2011 22



## Transition Curve

- ◆ Typical spirals (or transition curves) used in horizontal alignments are
  - Clothoid or ideal transition curve or Glover's spiral or Euler spiral
  - cubic spirals,
  - cubic parabola,
  - sinusoidal and
  - cosinusoidal.

Sunday, March 27, 2011 23



## Functions of Transition Curve

Primary functions of a transition curves (or easement curves) are:

- ◆ To accomplish gradual transition from the straight to circular curve, so that curvature changes from zero to a finite value.
- ◆ To provide a medium for gradual introduction or change of required superelevation.
- ◆ To changing curvature in compound and reverse curve cases, so that gradual change of curvature introduced from curve to curve.

Sunday, March 27, 2011 24

## Criteria of Transition Curve

To call a spiral between a straight and curve as **valid transition** curve, it has to satisfy the following conditions.

- ◆ One end of the spiral should be tangential to the straight.
- ◆ The other end should be tangential to the circular curve.
- ◆ Spiral's curvature at the intersection point with the circular arc should be equal to arc curvature.
- ◆ Also at the tangent its curvature should be zero.
- ◆ The rate of change of curvature along the transition should be same as that of the increase of cant or superelevation.
- ◆ Its length should be such that full cant is attained at the beginning of circular arc.

Sunday, March 27, 2011

25

## Necessity of Transition Curve

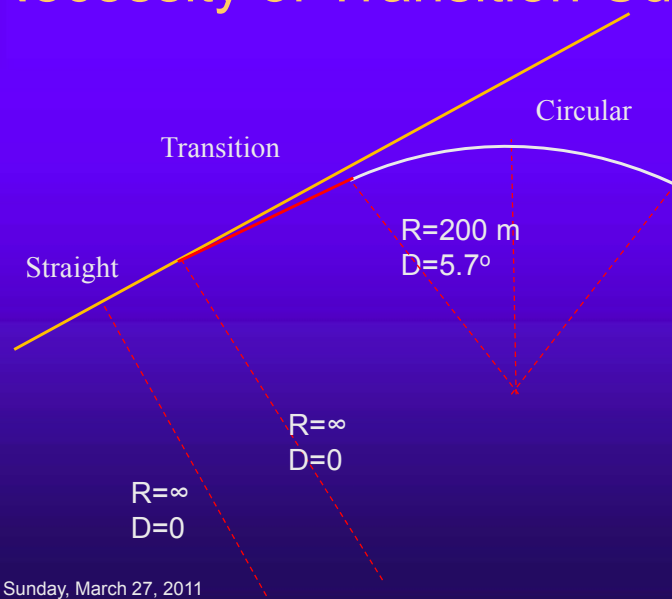

Sunday, March 27, 2011

26

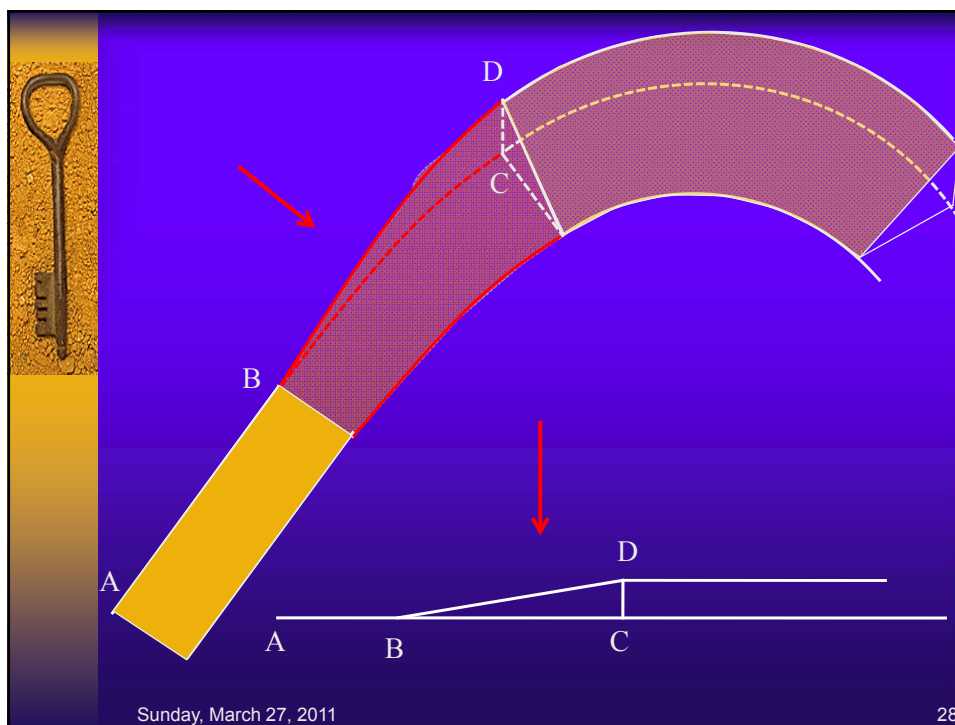
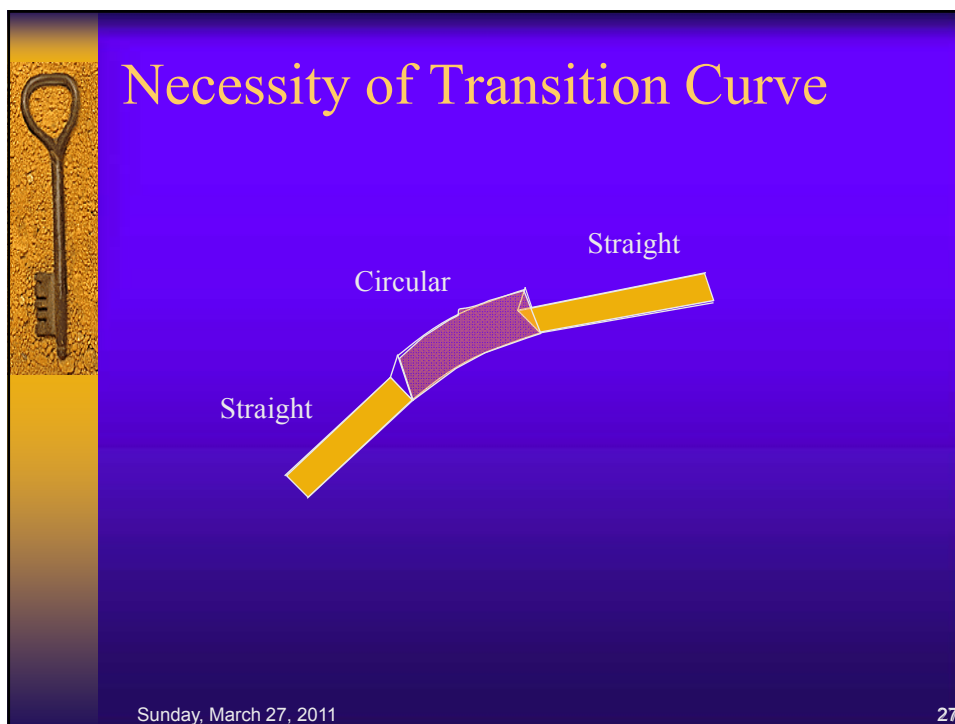



## Ideal Transition Curve

- ◆ An ideal transition curve is that which introduces centrifugal force at a gradual rate (by time  $t$ )
- ◆ So,  $F \propto t$
- ◆ Centrifugal force at any radius  $r$  is given by:

$$F = \frac{Wv^2}{gr} \propto t$$

- ◆ Assuming that the speed of the vehicle that is negotiating the curve is constant, the length of the transition negotiated too is directly proportional to the time.  $l \propto t$

Sunday, March 27, 2011

31

$$F = \frac{Wv^2}{gr} \propto t \quad l \propto t$$

$$l \propto \frac{1}{r} \propto t$$

$$\therefore lr = \text{const} = LR$$

- ◆ Thus, the fundamental requirement of a transition curve is that its radius of curvature at any given point shall vary inversely as the distance from the beginning of the spiral. **Such a curve is called clothoid of Glover's spiral** and is known as an ideal transition.

Sunday, March 27, 2011

32

$l = r\Delta$

$Curvature = \frac{1}{r}$

$\frac{1}{r} = \frac{\Delta}{l} = \frac{d\theta}{dl}$

Sunday, March 27, 2011

33

$Curvature = \frac{1}{r}$

$\frac{1}{r} = \frac{\theta}{l} = \frac{d\theta}{dl}$

Sunday, March 27, 2011

34

curve length= TQ=l

Curvature =  $\frac{1}{r}$

$\frac{1}{r} = \frac{d\theta}{dl}$

Sunday, March 27, 2011 35

$lr = LR$

$\frac{1}{r} = \frac{l}{LR}$

◆ As  $1/r$  is nothing but the curvature at that point, **curvature equation** can be written as:

$\frac{d\theta}{dl} = \frac{1}{r} = \frac{l}{LR}$        $d\theta = \frac{l}{LR} dl$

$\theta = \frac{l^2}{2RL} + C$

Sunday, March 27, 2011 36



$$\theta = \frac{l^2}{2RL} + C$$

Where  $\theta$  is the deflection angle from the tangent (at a point on spiral length  $l$ )

Apply boundary condition, at  $l = 0; \theta = 0$

Substituting these, we get  $C = 0$

So, the equation of ideal transition curve is

$$\theta = \frac{l^2}{2RL}$$

Sunday, March 27, 2011 37

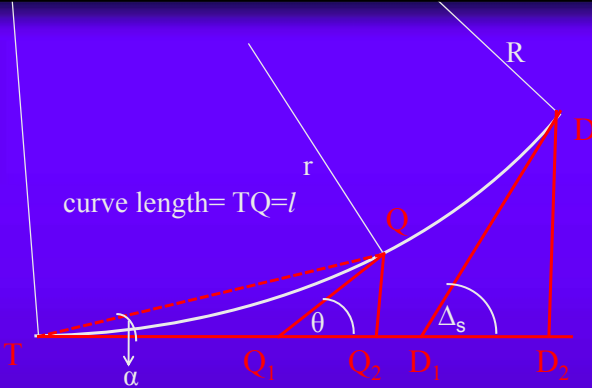
$$\theta = \frac{l^2}{2RL}$$

Apply boundary condition, at  $l = L; \theta = \Delta s, r = R$

Substituting these, we get spiral angle =

$$\Delta s = \frac{L}{2R}$$

Sunday, March 27, 2011 38

### Transfer to Cartesian Coordinates

curve length =  $TQ = l$

$\theta = \frac{l^2}{2RL}$

$$\frac{dx}{dl} = \cos \theta \quad dx = (\cos \theta) dl$$

$$x = l * \left[ 1 - \frac{l^4}{40R^2L^2} + \frac{l^8}{3456R^4L^4} - \dots \right]$$

Sunday, March 27, 2011 39

$$dx = dl \left( 1 - \frac{\theta^2}{!2} + \frac{\theta^4}{!4} - \frac{\theta^6}{!6} \dots \right)$$

$\theta = \frac{l^2}{2RL}$

$$x = l * \left[ 1 - \frac{l^4}{40R^2L^2} + \frac{l^8}{3456R^4L^4} - \dots \right]$$

Sunday, March 27, 2011 40

**Transfer to Cartesian Coordinates**

curve length =  $TQ = l$

$\theta = \frac{l^2}{2RL}$

$\frac{dy}{dl} = \sin \theta$        $dy = (\sin \theta) dl$

$y = \frac{l^3}{6RL} \left[ 1 - \frac{l^4}{56R^2L^2} + \frac{l^8}{7040R^4L^4} - \dots \right]$

Sunday, March 27, 2011 41

$dy = dl \left( \theta - \frac{\theta^3}{!3} + \frac{\theta^5}{!5} - \frac{\theta^7}{!7} \dots \right)$        $\theta = \frac{l^2}{2RL}$

$y = \frac{l^3}{6RL} \left[ 1 - \frac{l^4}{56R^2L^2} + \frac{l^8}{7040R^4L^4} - \dots \right]$

Sunday, March 27, 2011 42

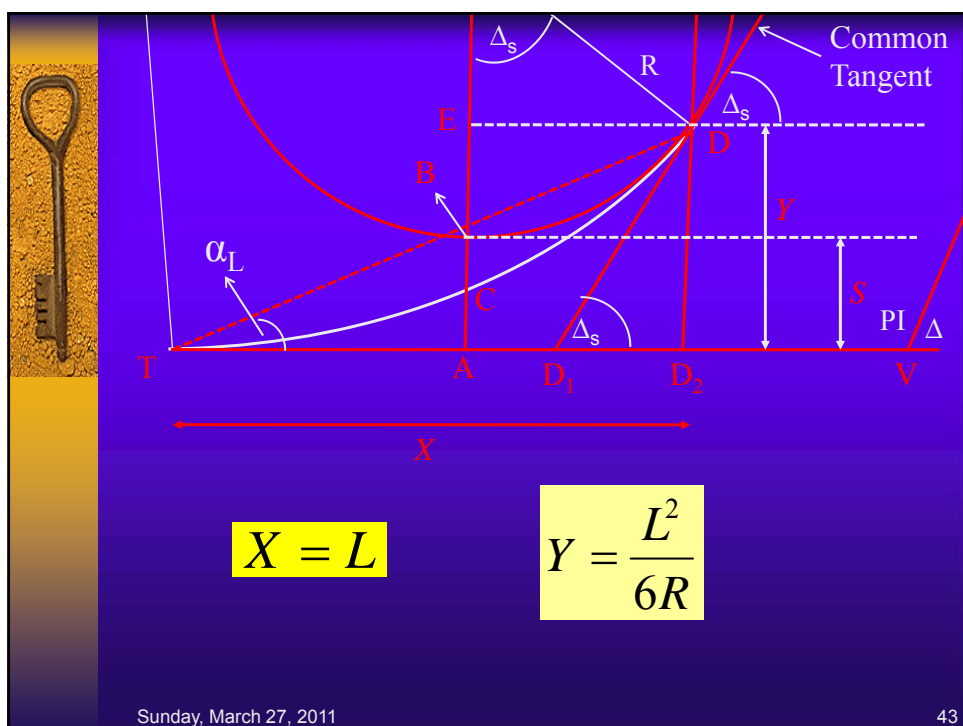

$\theta = \frac{l^2}{2RL}$

$x = l * [1 - \frac{l^4}{40R^2L^2} + \frac{l^8}{3456R^4L^4} - \dots]$

$x = l$        $X = L$

$y = \frac{l^3}{6RL} [1 - \frac{l^4}{56R^2L^2} + \frac{l^8}{7040R^4L^4} - \dots]$

$y = \frac{l^3}{6RL}$        $y = \frac{x^3}{6RL}$        $Y = \frac{L^3}{6RL}$        $Y = \frac{L^2}{6R}$

Sunday, March 27, 2011 44



$\theta = \frac{l^2}{2RL}$

Clothoid or Ideal Transition Curve

$y = \frac{l^3}{6RL}$

Cubic Spiral

$y = \frac{x^3}{6RL}$

Cubic Parabola

Sunday, March 27, 2011 45



Polar deflection angle,  $\alpha$

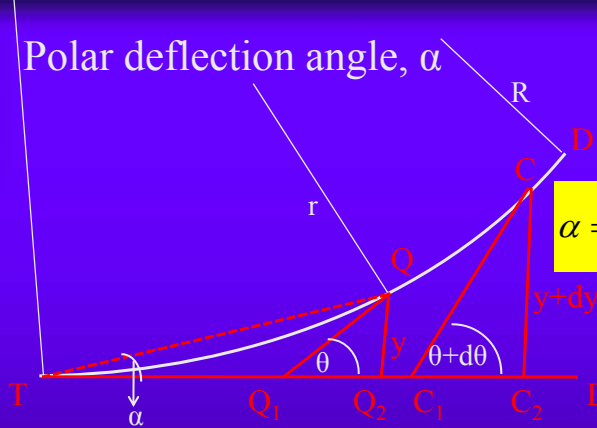

$\alpha = \tan^{-1}\left(\frac{y}{x}\right) \cong \frac{\theta}{3}$

$\alpha = \frac{l^2}{6RL}$

$\theta = \frac{l^2}{2RL}$

$x = l * \left[ 1 - \frac{l^4}{40R^2L^2} + \frac{l^8}{3456R^4L^4} - \dots \right]$

$y = \frac{l^3}{6RL} \left[ 1 - \frac{l^4}{56R^2L^2} + \frac{l^8}{7040R^4L^4} - \dots \right]$

Sunday, March 27, 2011 46

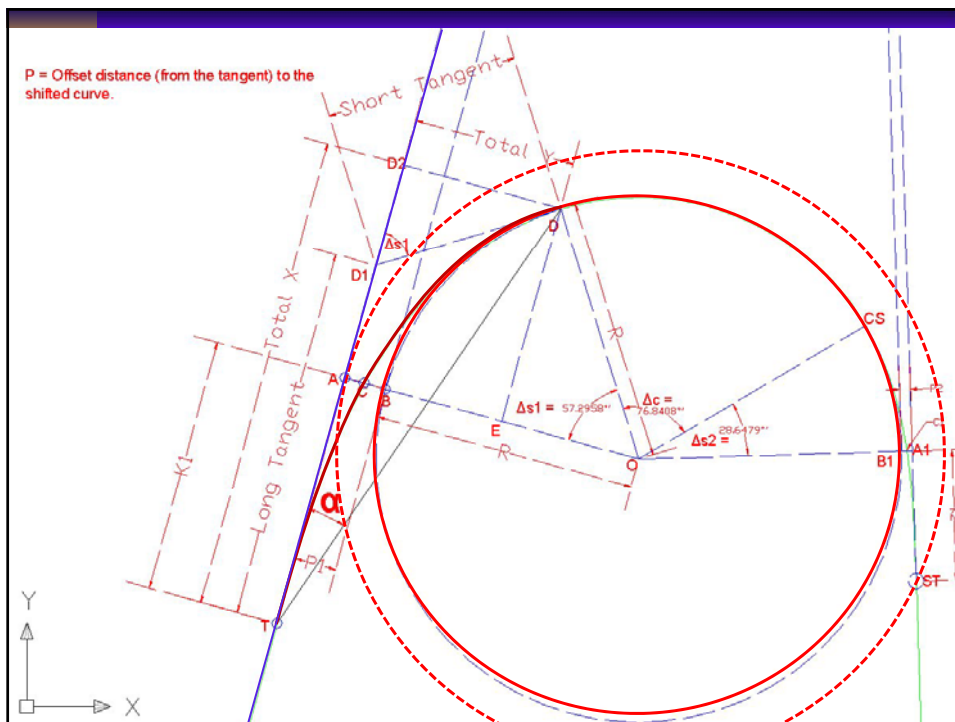

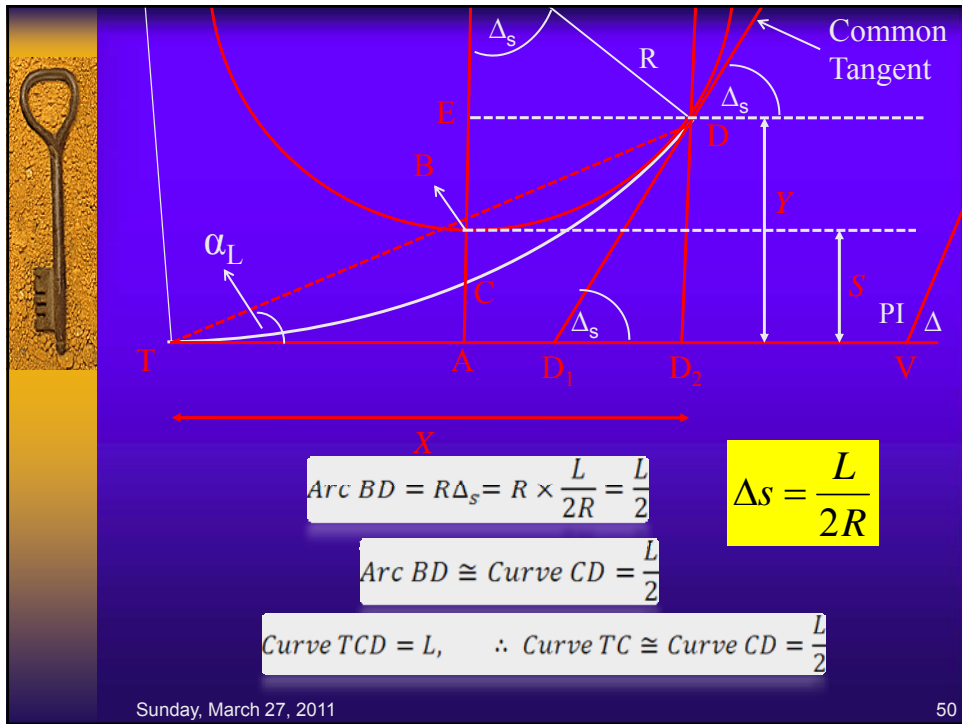
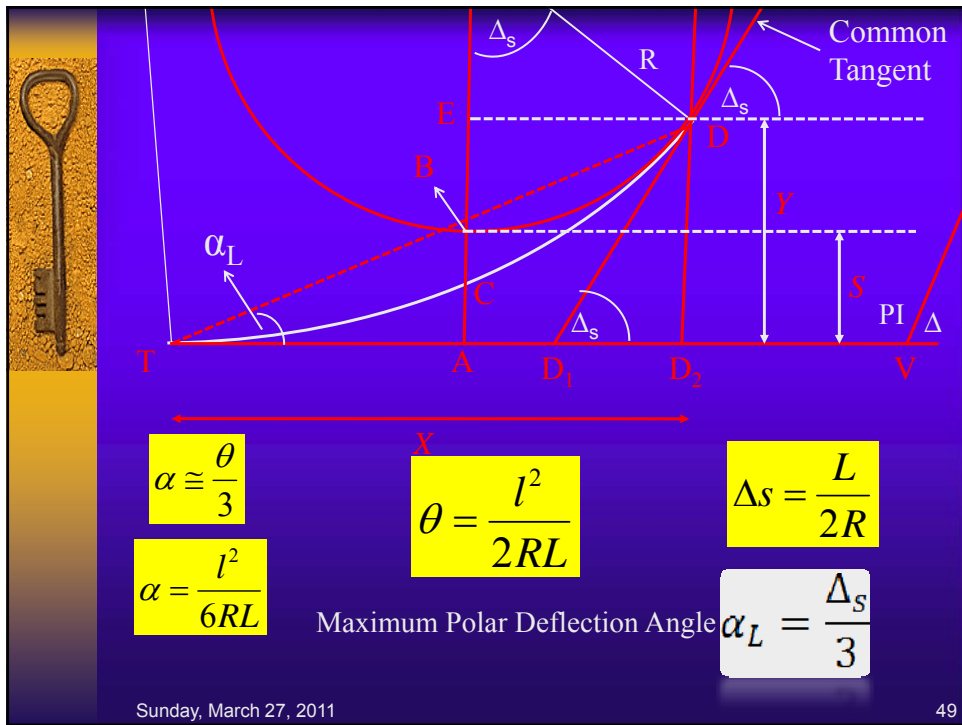

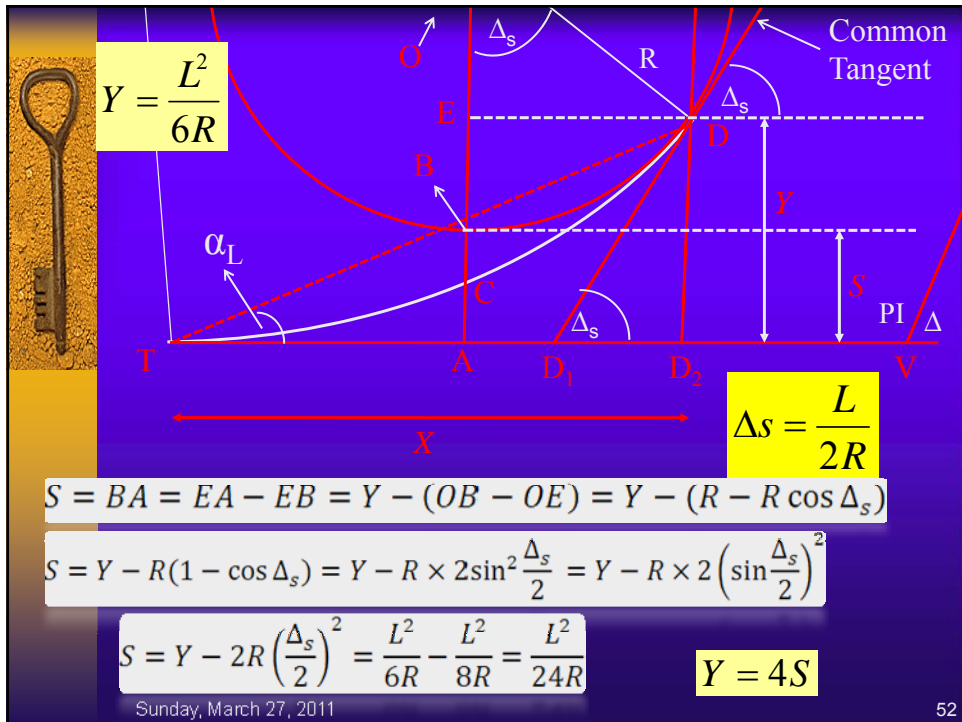
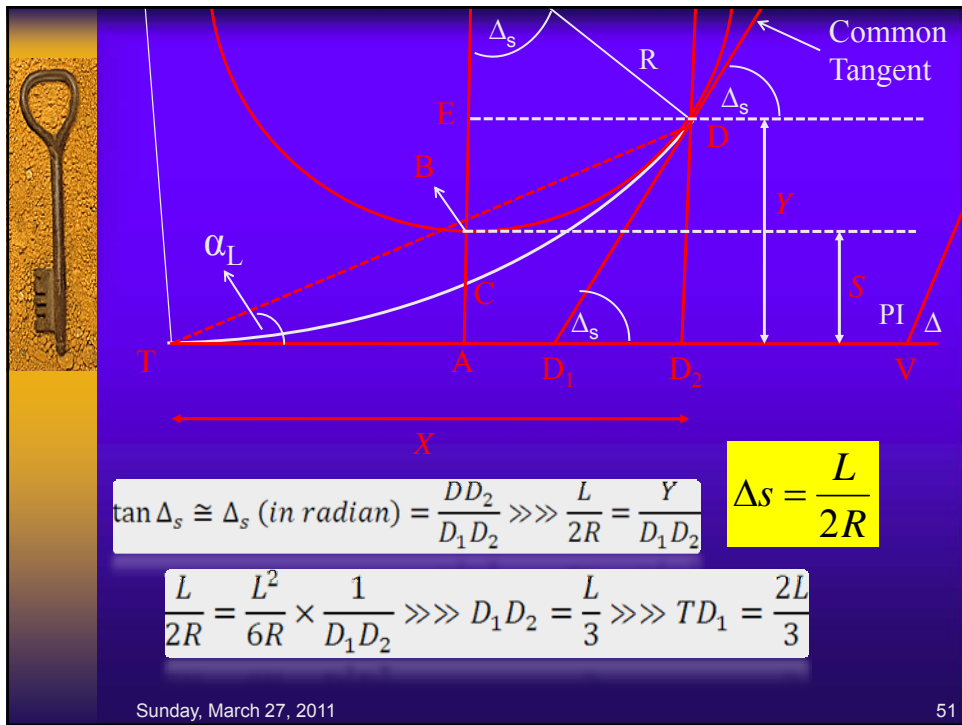

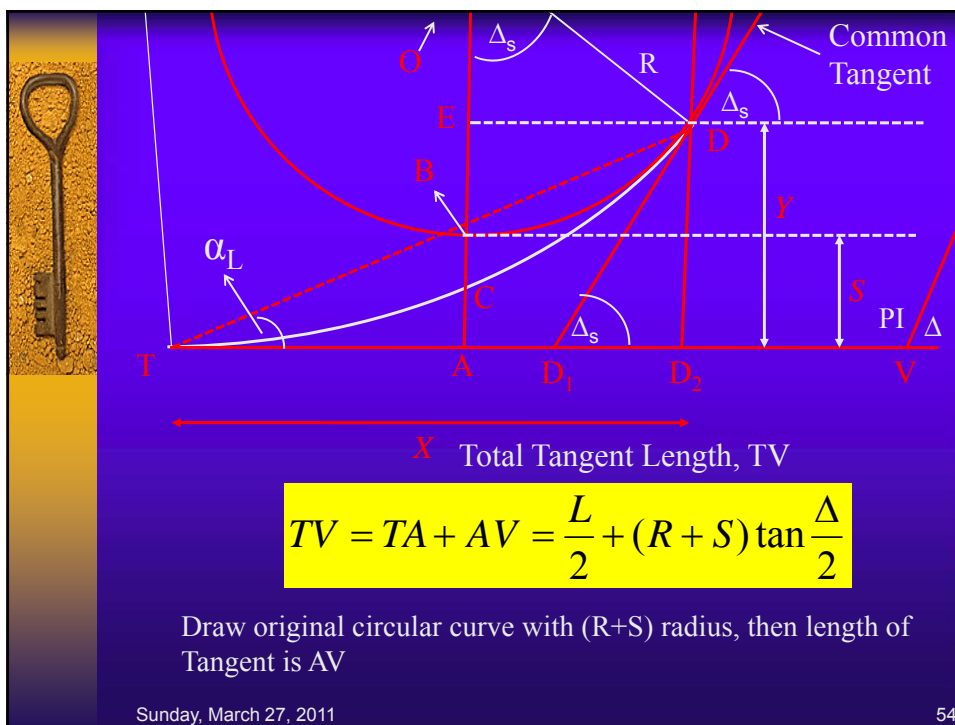
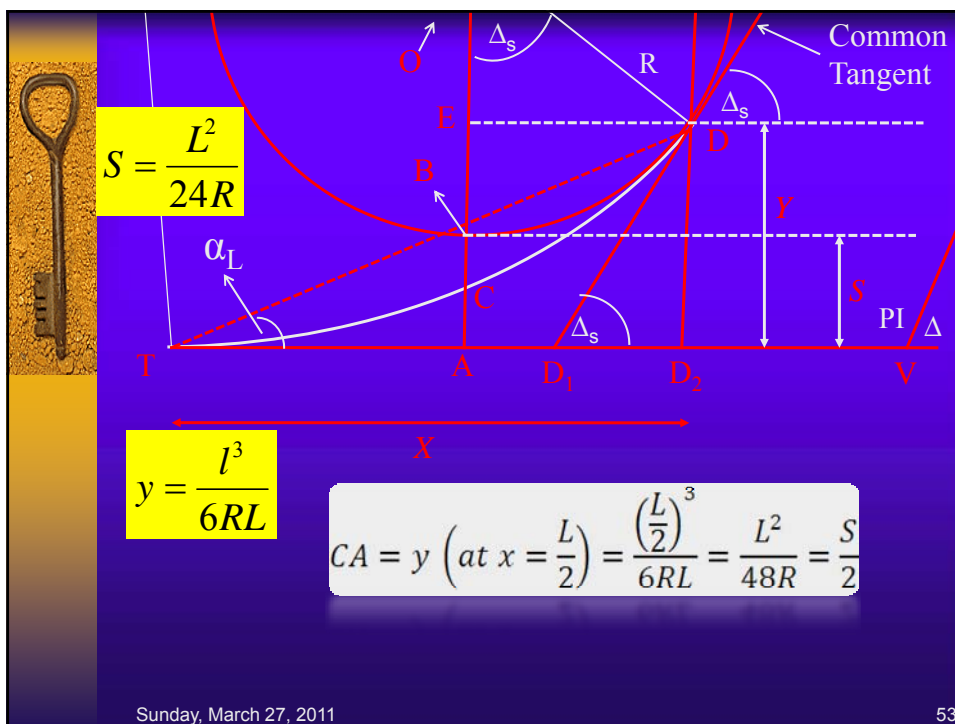

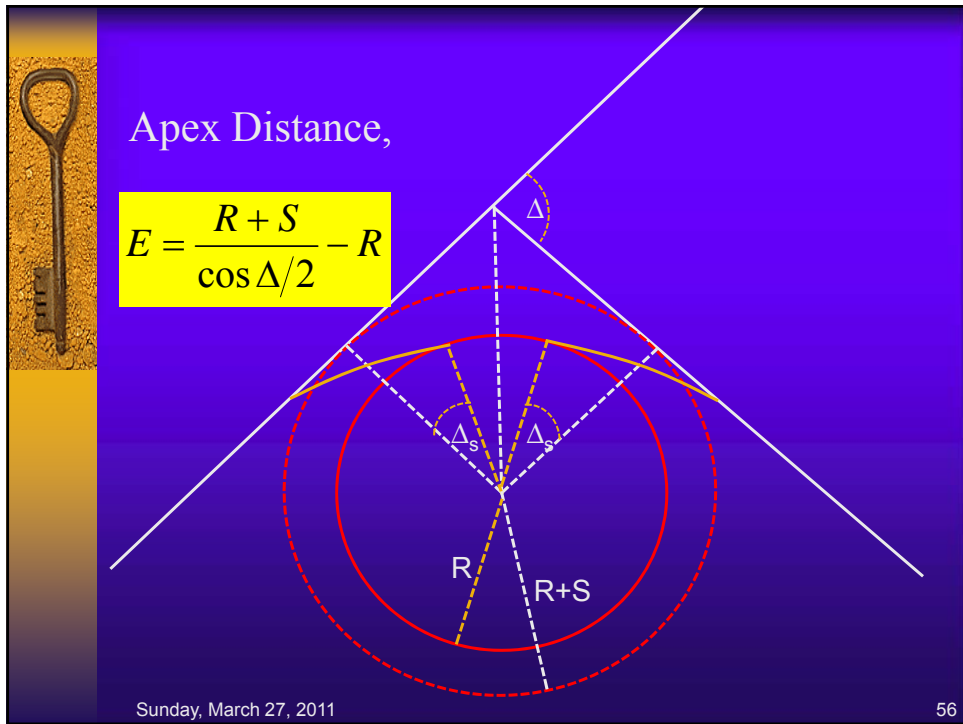
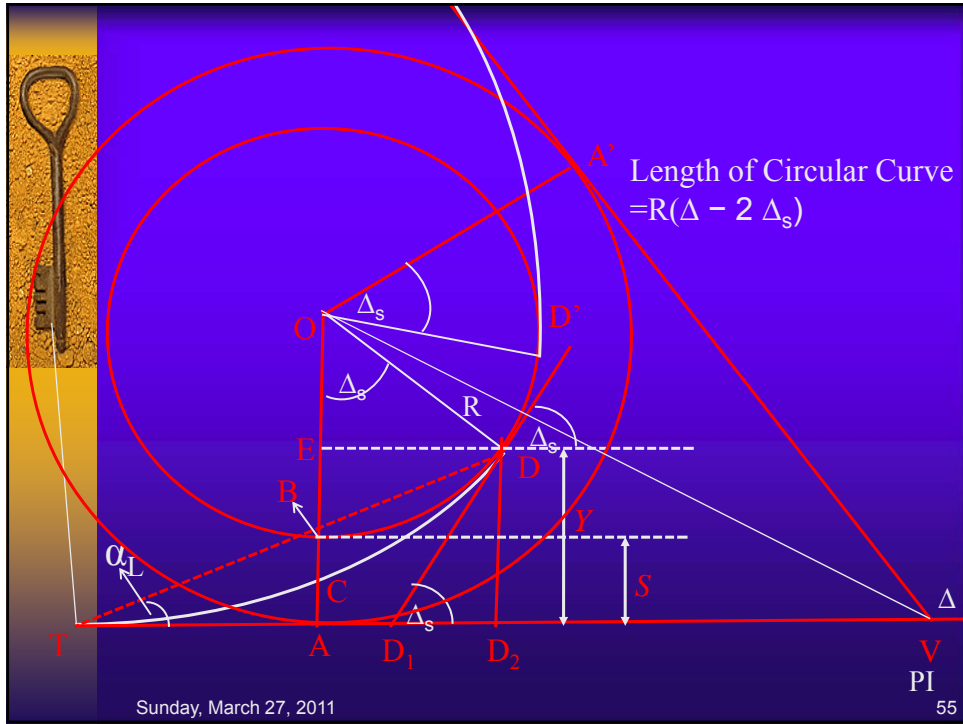

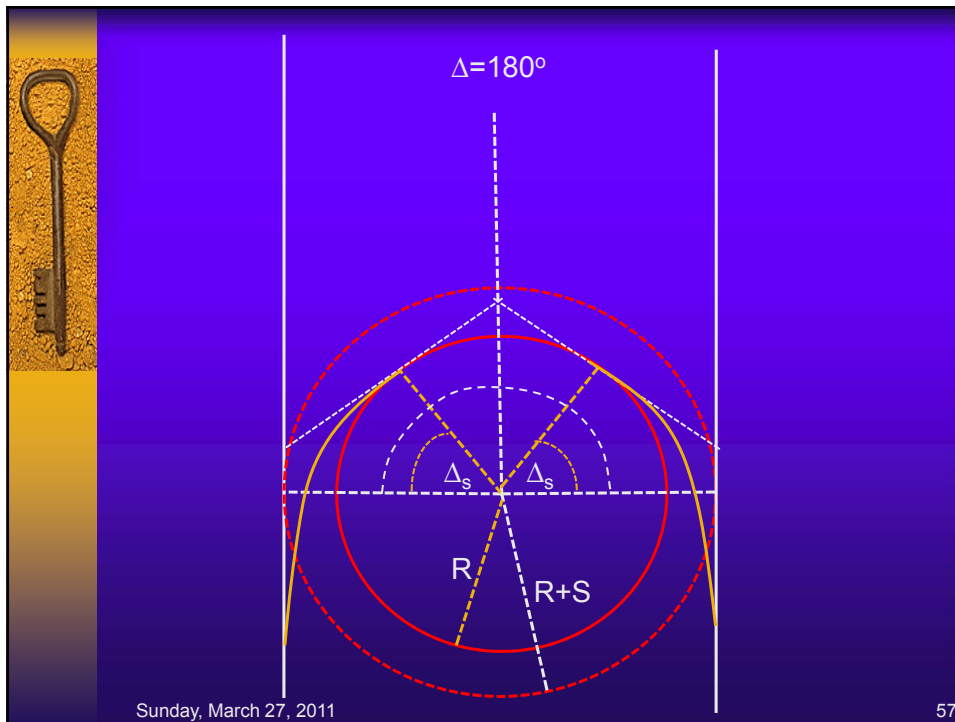

**Formula**

$\theta = \frac{l^2}{2RL}$

$y = \frac{l^3}{6RL}$

$y = \frac{x^3}{6RL}$

$\alpha \cong \frac{\theta}{3}$

$\Delta s = \frac{L}{2R}$

$E = \frac{R+S}{\cos \Delta/2} - R$

$TD_1 = \frac{2L}{3}$

$S = \frac{L^2}{24R}$

$$TV = TA + AV = \frac{L}{2} + (R+S) \tan \frac{\Delta}{2}$$

Sunday, March 27, 2011 58

RELATION among  
Design speed,  
Radius of curvature,  
Rate of superelevation,  
Side friction

Sunday, March 27, 2011 59

$F_s = fN$ , where  $f$  is static friction coefficient  
 $\tan\phi = e = \text{rate of superelevation}$

$$\frac{WV^2}{gR} - N \sin \phi - F_s \cos \phi = 0 \dots \dots \dots (1)$$

$$\frac{WV^2}{gR} = N \sin \phi + fN \cos \phi$$

$$W = \frac{N}{\frac{V^2}{gR}} (\sin \phi + f \cos \phi)$$

Sunday, March 27, 2011 60

$F_s = fN$ , where  $f$  is static friction coefficient  
 $\tan\phi = e = \text{rate of superelevation}$

$-W + N \cos \phi - F_s \sin \phi = 0 \dots \dots \dots (2)$

$W = N \cos \phi - fN \sin \phi = N(\cos \phi - f \sin \phi)$

Sunday, March 27, 2011 61

$$N(\cos \phi - f \sin \phi) = \frac{N}{\frac{V^2}{gR}} (\sin \phi + f \cos \phi)$$

$$\frac{V^2}{gR} = \frac{\sin \phi + f \cos \phi}{\cos \phi - f \sin \phi}$$

$$\frac{V^2}{gR} = \frac{\tan \phi + f}{1 - f \tan \phi}$$

$$\frac{V^2}{gR} = \frac{e + f}{1 - ef}$$

$$e + f = \frac{V^2}{gR}$$

The value of the product **ef** in this equation is always small. As a result, **(1-ef)** term is normally omitted in highway and street designs, thus providing slightly more conservative values.

Sunday, March 27, 2011 62



$$e + f = \frac{V^2}{gR}$$

This equation can be used in any consistent unit

If we express V in mph and R in ft, then equation becomes

$$e + f = \frac{V^2}{15R}$$

The minimum safe radius,  $R_{\min}$

$$R_{\min} = \frac{V^2}{g(e + f)}$$

If we express V in mph

$$D_{\max} = \frac{85,660(e + f)}{V^2}$$

Sunday, March 27, 2011 63



$$\frac{V^2}{gR} = \frac{e + f}{1 - ef}$$

When a vehicle travels at a constant speed on a curve  
Superelevated so that the f value is zero, the centrifugal  
force is balanced by the weight component of the vehicle,  
and theoretically no steering force is required.

A vehicle traveling faster or slower than the balance speed  
develops tire friction as steering effort is applied to  
prevent movement to the outside or to the inside of the  
curve

On non superelevated curves, travel at different speeds is  
also possible by utilizing side friction in appropriated  
amounts to resist the varying centrifugal force.

Sunday, March 27, 2011 64

Radius of circular curve can be determined by  $\frac{V^2}{gR} = \frac{e + f}{1 - ef}$

1. Method of maximum friction and
2. Method of maximum rate of superelevation

1. Method of maximum friction  $\rightarrow e=0$ ,  $f = \frac{V^2}{gR}$   $R = \frac{V^2}{gf}$
2. Method of maximum rate of superelevation,  $\rightarrow f=0$ ,  $e = \frac{V^2}{gR}$   $R = \frac{V^2}{ge}$

Sunday, March 27, 2011 65

## Rate of superelevation, e

- ◆ There is a practical limit to the rate of superelevation. In areas subject to ice, snow, rain water or saline water, e can not be greater than that on which vehicle standing or traveling slowly would slide down the cross slope.
- ◆ At higher speeds, the phenomenon of partial hydroplaning can occur on curves with poor surface drainage.

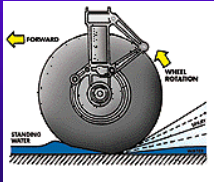

Partial hydroplaning

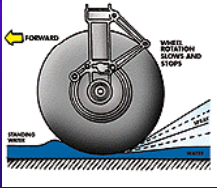

Total hydroplaning

Sunday, March 27, 2011 66



## Maximum rate of superelevation, $e_{\max}$

- ◆  $e_{\max} = 0.12$  (if there is no snow and ice on road)
- ◆  $e_{\max} = 0.08$  (if there would be snow and ice on road)
- ◆  $e_{\max} = 0.08$  (good and reasonable value for all purposes)

**Transition curve**



Road width =  $b$

**Circular curve**



Road width =  $b$

Sunday, March 27, 2011 67



## Side Friction Factor, $f$

- ◆ Unbalanced centrifugal force is counterbalanced by side friction between tires and road surface
- ◆ Side friction factor ( $f$ ) at which side skidding is imminent depends on a number of factors
  - Type and condition of road surface
  - Type and condition of tyre
  - Speed of vehicle

Sunday, March 27, 2011 68



**AASHTO =**  
The American Association of State Highway and Transportation Officials

- ◆ Following tables were made by AASHTO (see “AASHTO – Geometric Design of Highways and Streets”)

Sunday, March 27, 2011 69



**Table III-6. Maximum degree of curve and minimum radius determined for limiting values of e and f, rural highways and high speed urban streets.**

Design speed (mph)	$e_{max}$	$f_{max}$	$(e+f)_{max}$	$D_{max}$	Rounded	
					$D_{max}$	$R_{min}$ (ft)
20	0.04	0.17	0.21	44.97	45.00	127
30	0.04	0.16	0.20	19.04	19.00	302
40	0.04	0.15	0.19	10.17	10.00	573
50	0.04	0.14	0.18	6.17	6.00	955
55	0.04	0.13	0.17	4.81	4.75	1206
60	0.04	0.12	0.16	3.81	3.75	1528

Sunday, March 27, 2011 70



**Table III-6. Maximum degree of curve and minimum radius determined for limiting values of e and f, rural highways and high speed urban streets.**

Design speed (mph)	$e_{max}$	$f_{max}$	$(e+f)_{max}$	$D_{max}$	Rounded $D_{max}$	$R_{min}$ (ft)
20	0.06	0.17	0.23	49.25	49.25	116
30	0.06	0.16	0.22	20.94	21.00	273
40	0.06	0.15	0.21	11.24	11.25	509
50	0.06	0.14	0.20	6.85	6.75	849
55	0.06	0.13	0.19	5.38	5.50	1042
60	0.06	0.12	0.18	4.28	4.25	1348
65	0.06	0.11	0.17	3.45	3.50	1637
70	0.06	0.10	0.16	2.80	2.75	2083

Sunday, March 27, 2011 71



**Table III-6. Maximum degree of curve and minimum radius determined for limiting values of e and f, rural highways and high speed urban streets.**

Design speed (mph)	$e_{max}$	$f_{max}$	$(e+f)_{max}$	$D_{max}$	Rounded $D_{max}$	$R_{min}$ (ft)
20	0.08	0.17	0.25	53.54	53.50	107
30	0.08	0.16	0.24	22.84	22.75	252
40	0.08	0.15	0.23	12.31	12.25	468
50	0.08	0.14	0.22	7.54	7.50	764
55	0.08	0.13	0.21	5.95	6.00	955
60	0.08	0.12	0.20	4.76	4.75	1206
65	0.08	0.11	0.19	3.85	3.75	1528
70	0.08	0.10	0.18	3.15	3.00	1910

Sunday, March 27, 2011 72



**Table III-6. Maximum degree of curve and minimum radius determined for limiting values of e and f, rural highways and high speed urban streets.**

Design speed (mph)	$e_{max}$	$f_{max}$	$(e+f)_{max}$	$D_{max}$	Rounded $D_{max}$	$R_{min}$ (ft)
20	0.10	0.17	0.27	57.82	58.00	99
30	0.10	0.16	0.26	24.75	24.75	231
40	0.10	0.15	0.25	13.38	13.25	432
50	0.10	0.14	0.24	8.22	8.25	694
55	0.10	0.13	0.23	6.51	6.50	881
60	0.10	0.12	0.22	5.23	5.25	1091
65	0.10	0.11	0.21	4.26	4.25	1348
70	0.10	0.10	0.20	3.50	3.50	1637

Sunday, March 27, 2011 73



**Table III-6. Maximum degree of curve and minimum radius determined for limiting values of e and f, rural highways and high speed urban streets.**

Design speed (mph)	$e_{max}$	$f_{max}$	$(e+f)_{max}$	$D_{max}$	Rounded $D_{max}$	$R_{min}$ (ft)
20	0.12	0.17	0.29	62.10	62.00	92
30	0.12	0.16	0.28	26.65	26.75	214
40	0.12	0.15	0.27	14.46	14.50	395
50	0.12	0.14	0.26	8.91	9.00	637
55	0.12	0.13	0.25	7.08	7.00	819
60	0.12	0.12	0.24	5.71	5.75	996
65	0.12	0.11	0.23	4.66	4.75	1206
70	0.12	0.10	0.22	3.85	3.75	1528

Sunday, March 27, 2011 74

## Miscellaneous

- ◆ Find the sharpest curve without superelevation for design speed  $V$ .
- ◆ Crown of road to facilitate surface drainage
  - 0.40 to 2% slope for paved road
  - 4% to 6% for unpaved road
- ◆ What type of crown should be provided in a curved road?

Sunday, March 27, 2011

75

### Types of Crown

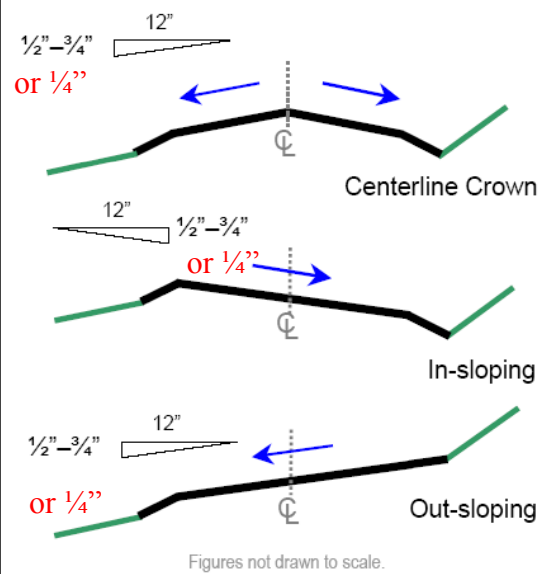

Sunday, March 27, 2011

76

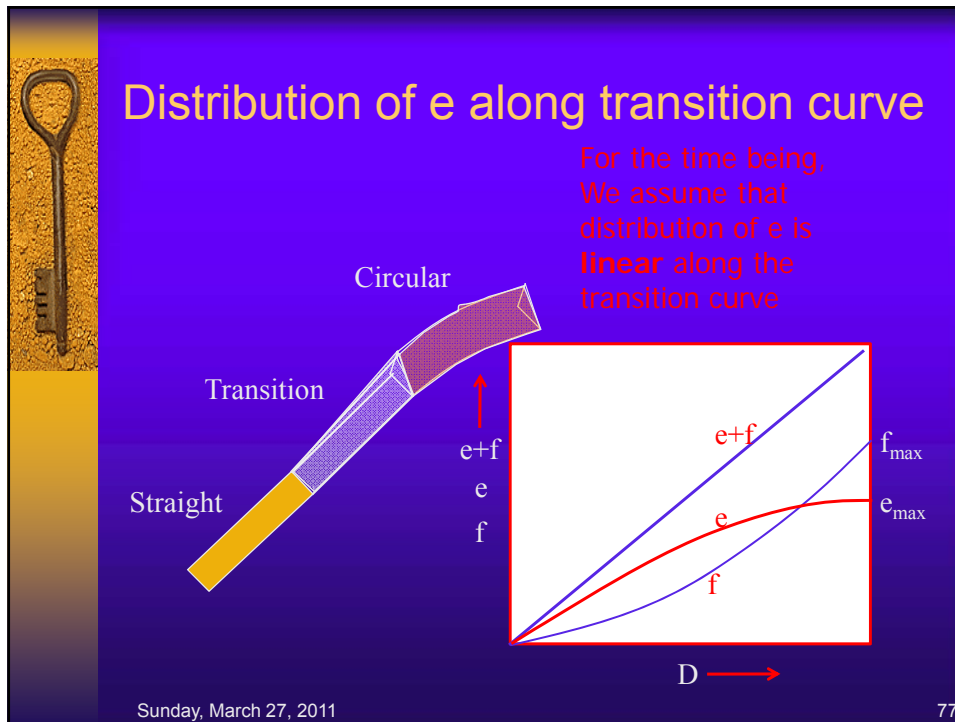

## Length of transition curve (considering comfort)

- ◆ The following equation developed in 1909 by Shortt for gradual attainment of centripetal acceleration on railroad track curves, is the basic expression used by some engineers for computing minimum length of spiral:

$$L = \frac{3.15V^3}{RC}$$

$$L = \frac{V^3}{RC}$$

- ◆ L = minimum length of spiral, ft In consistent unit
- ◆ V = speed, mph
- ◆ R = radius, ft
- ◆ C = rate of increase of centripetal acceleration, ft/s<sup>3</sup>
- ◆ = 1 for railroad, 1 to 3 for highways

Sunday, March 27, 2011 78



Radial acceleration or centripetal acceleration ( $V^2/r$ ) changes from 0 to  $V^2/R$  from starting of spiral to end of spiral.

So, rate of change of centripetal acceleration,

$$C = \frac{\frac{V^2}{R} - 0}{T}, V = \frac{L}{T} \implies T = \frac{L}{V}$$

$$C = \frac{V^2}{RT} = \frac{V^2}{R \frac{L}{V}} = \frac{V^3}{RL}$$

$$L = \frac{V^3}{RC}$$

Sunday, March 27, 2011 79



- ◆ Highways do not appear to need as much precision as is obtained from computing the length of spiral by this formula.
- ◆ A more practical control for the length of spiral is that in which it equals the length required for **superelevation runoff**.

Sunday, March 27, 2011 80



## Superelevation runoff

- ◆ Length of highway needed to accomplish the change in cross slope from a section with adverse crown removed to a fully superelevated section, or vice versa.

## Tangent runout

- ◆ Length of highway needed to accomplish the change in cross slope from a normal crown section to a section with the adverse crown removed, or vice versa.

Sunday, March 27, 2011 81



## Methods of attaining superelevation

- ◆ 1. revolving a crowned pavement about the centerline profile
- ◆ 2. revolving a crowned pavement about the inside-edge profile
- ◆ 3. revolving a crowned pavement about the outside-edge profile
- ◆ 4. revolving a straight cross-slope pavement about the outside-edge profile

Sunday, March 27, 2011 82

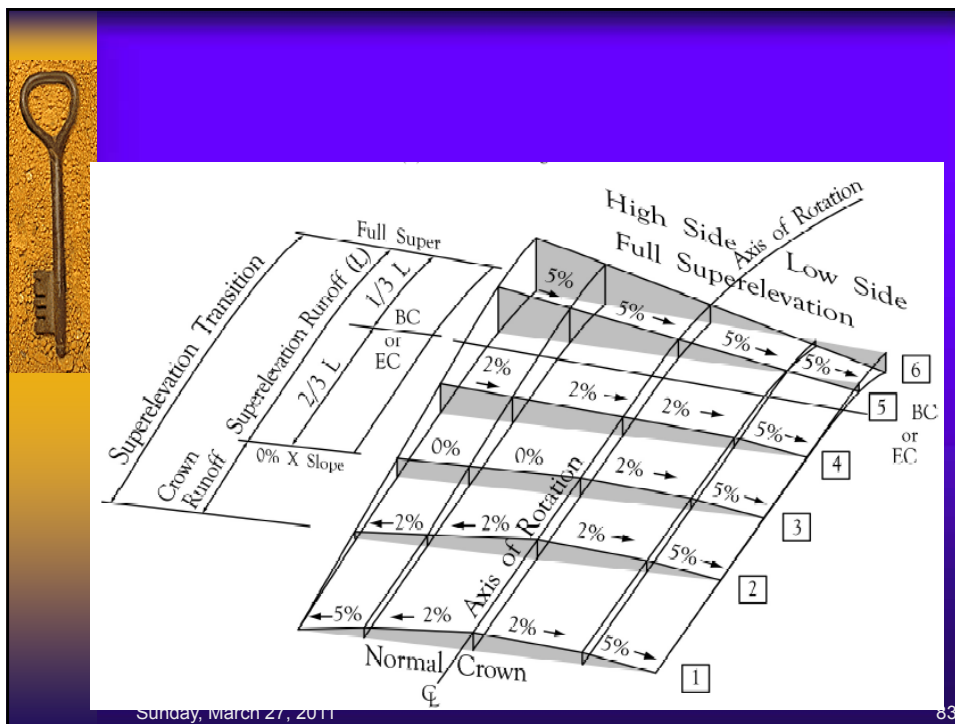

Sunday, March 27, 2011

83

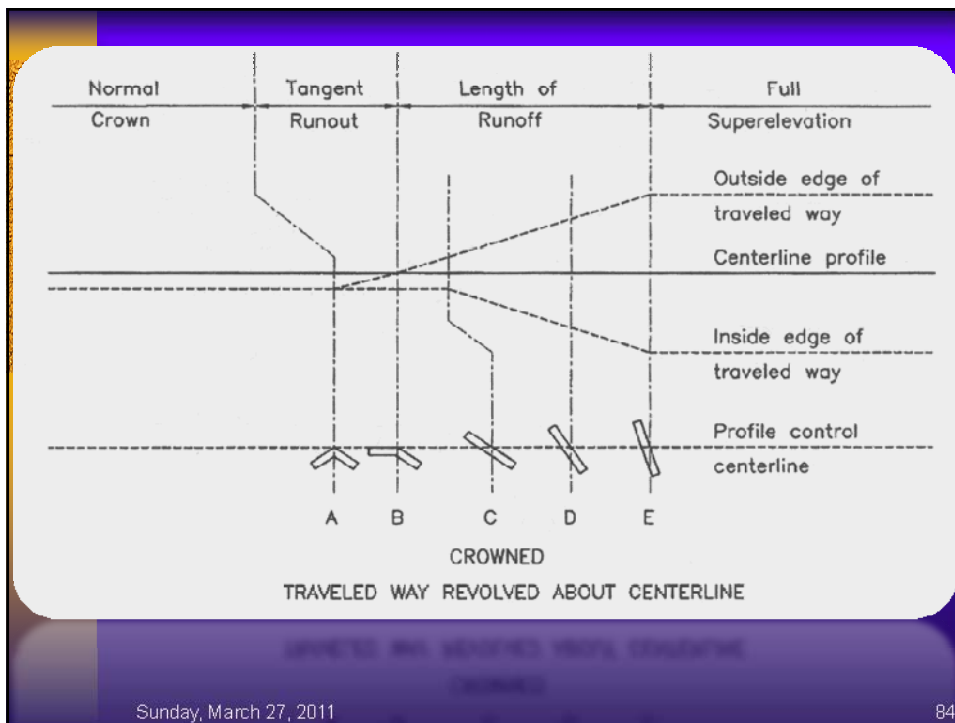

Sunday, March 27, 2011

84

# Superelevation Runoff/Runout

Metric								US Customary							
Design speed (km/h)	Minimum runoff and runout length (m)							Design speed (mph)	Minimum runoff and runout length (ft)						
	Runoff								Runoff						
	Superelevation								Superelevation						
	2	4	6	8	10	12	any		2	4	6	8	10	12	any
One lane rotated								One lane rotated							
20	9	18	27	36	45	54	9	15	31	61	92	123	154	184	31
30	10	19	29	38	48	57	10	20	32	65	97	130	162	194	32
40	10	21	31	41	51	62	10	25	34	69	103	137	172	206	34
50	11	22	32	43	54	65	11	30	38	73	109	148	182	219	36
60	12	24	36	48	60	72	12	35	39	77	116	155	193	232	39
70	13	26	39	52	66	79	13	40	41	83	124	165	206	248	41
80	14	29	43	58	72	86	14	45	44	89	133	178	222	266	44
90	15	31	46	61	77	92	15	50	48	96	144	192	240	288	48
100	16	33	49	65	82	98	16	55	51	102	153	204	256	307	51
110	18	35	53	70	88	105	18	60	53	107	160	213	266	320	53
120	19	38	57	76	95	114	19	65	56	112	168	224	280	336	56
130	21	41	62	82	103	124	21	70	60	120	180	240	300	360	60
								75	63	126	189	252	316	379	63
								80	69	137	206	275	343	412	69
Two lanes rotated								Two lanes rotated							
20	14	27	41	54	68	81	14	15	46	92	138	184	230	276	46
30	14	29	43	57	72	88	14	20	49	97	148	194	243	282	49
40	15	31	46	62	77	93	15	25	51	103	154	208	257	309	51
50	16	32	49	65	81	97	16	30	55	109	164	219	274	328	55
60	18	36	54	72	90	108	18	35	58	116	174	232	290	348	58
70	20	39	59	79	98	118	20	40	62	124	186	248	310	372	62
80	22	43	65	86	108	130	22	45	67	133	200	266	333	400	67
90	23	46	69	92	115	138	23	50	72	144	216	288	360	432	72
100	25	49	74	98	123	147	25	55	77	153	230	307	383	460	77
110	28	53	79	105	132	158	28	60	80	160	240	320	400	480	80
120	28	57	85	114	142	170	28	65	84	168	252	336	419	503	84
130	31	62	93	124	154	185	31	70	90	180	270	360	450	540	90
								75	95	189	284	379	473	568	95
								80	103	206	309	412	516	618	103

Note: Based on 3.6 m (12 ft) lanes and on a 2.0% normal cross slope.

# Superelevation Runoff/Runout

Metric							
Design speed (km/h)	Minimum runoff and runout length (m)						
	Runoff						
	Superelevation						
	2	4	6	8	10	12	any
One lane rotated							
20	9	18	27	36	45	54	9
30	10	19	29	38	48	57	10
40	10	21	31	41	51	62	10
50	11	22	32	43	54	65	11
60	12	24	36	48	60	72	12
70	13	26	39	52	66	79	13
80	14	29	43	58	72	86	14
90	15	31	46	61	77	92	15
100	16	33	49	65	82	98	16
110	18	35	53	70	88	105	18
120	19	38	57	76	95	114	19
130	21	41	62	82	103	124	21

## Desirable Spiral Lengths

Metric		US Customary	
Design speed (km/h)	Spiral length (m)	Design speed (mph)	Spiral length (ft)
20	11	15	44
30	17	20	59
40	22	25	74
50	28	30	88
60	33	35	103
70	39	40	117
80	44	45	132
90	50	50	147
100	56	55	161
110	61	60	176
120	67	65	191
130	72	70	205
		75	220
		80	235

Sunday, March 27, 2011

87

## Stopping Sight Distance

$$SSD = \frac{\pi}{180} R_v \Delta_s = \frac{100 \Delta_s}{D}$$

$$\Delta_s = \frac{180(SSD)}{\pi R_v}$$

$$M_s = R_v \left[ 1 - \cos \left( \frac{90 SSD}{\pi R_v} \right) \right]$$

$$SSD = \frac{\pi R_v}{90} \left[ \cos^{-1} \left( \frac{R_v - M_s}{R_v} \right) \right]$$

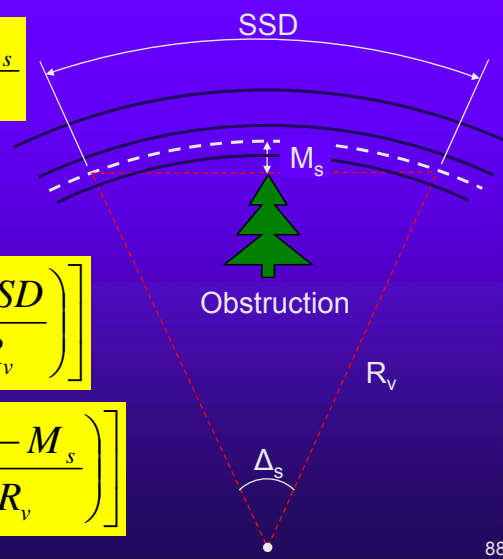

Sunday, March 27, 2011

88

## Design of Horizontal Alignment of Road (Design speed and deflection is known)

- ◆ 1. Assume  $e_{\max} = ?$ , get  $f_{\max} = ?$  From Table III-4, Determine  $R_{\min} = ?$ ,  $D_{\max} = ?$
- ◆ 2. Determine  $L = ?$
- ◆ 3. Calculate geometric elements of transition and circular curve
- ◆ 4. Plotting the road alignment with longitudinal and cross profiles
- ◆ 5. Select the method of setting out transition and circular curve and perform necessary calculations for that method of setting out
- ◆ 6. Stake out in the field using surveying instruments

Sunday, March 27, 2011

89

### Setting out circular curve

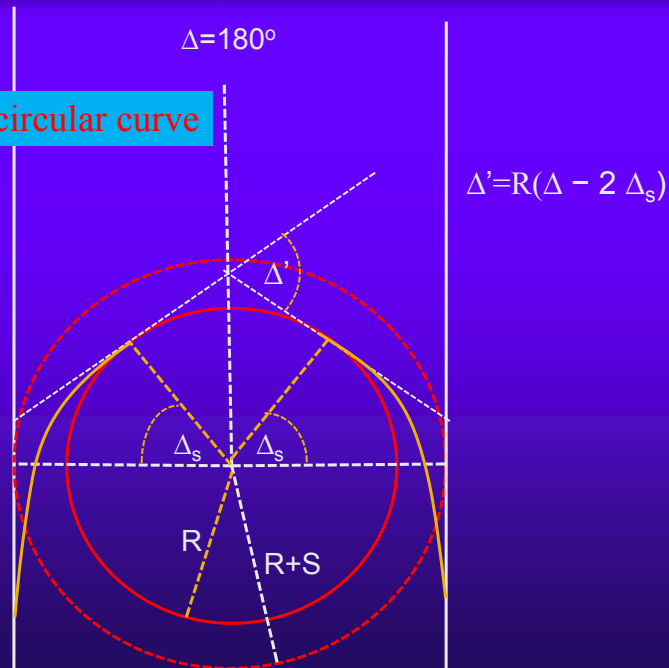

Sunday, March 27, 2011

90

