

CE 410: Concrete Structures Design Sessional II

Design of Prestressed Concrete I-Girder Bridge

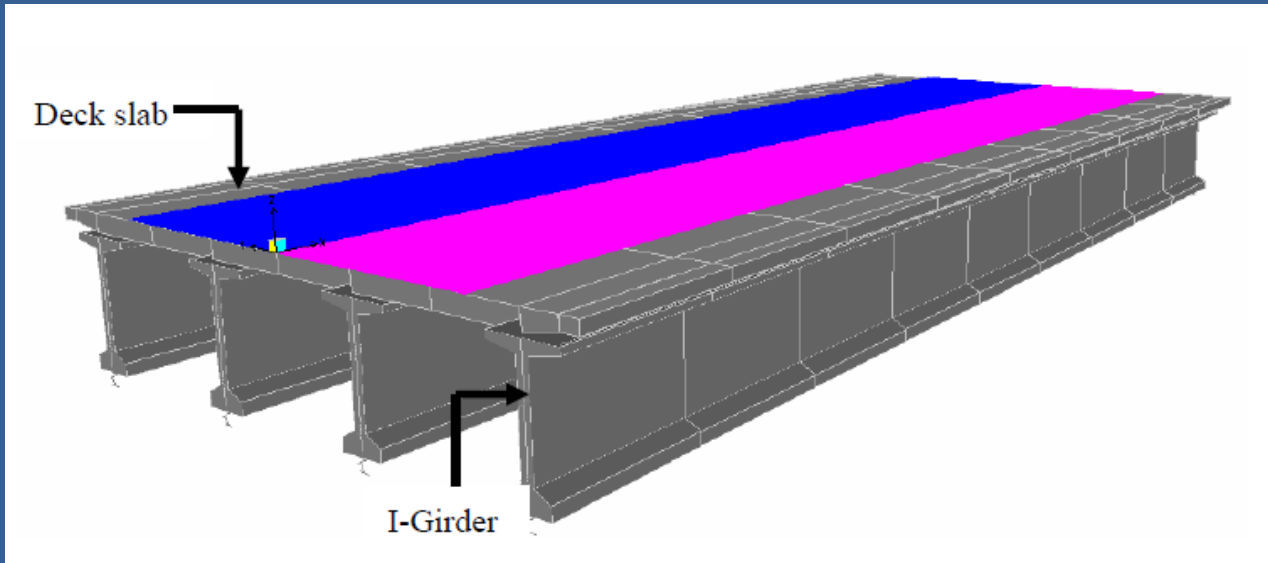









Outline

- Basics of Prestress
- LRFD method
- Load-HL93
- Design of PC I-girder bridge
 - Slab design
 - Girder design
 - etc

Prestress

1. Introduction

1.1 *Background*

The idea of prestressed concrete has been around since the latter decades of the 19th century, but its use was limited by the quality of the materials at the time. It took until the 1920s and '30s for its materials development to progress to a level where prestressed concrete could be used with confidence. Freyssinet in France, Magnel in Belgium and Hoyer in Germany were the principle developers.

The idea of prestressing has also been applied to many other forms, such as:

- Wagon wheels;
- Riveting;
- Barrels, i.e. the coopers trade;

In these cases heated metal is made to just fit an object. When the metal cools it contracts inducing prestress into the object.

1.2 *Basic Principle of Prestressing*

Basic Example

The classic everyday example of prestressing is this: a row of books can be lifted by squeezing the ends together:

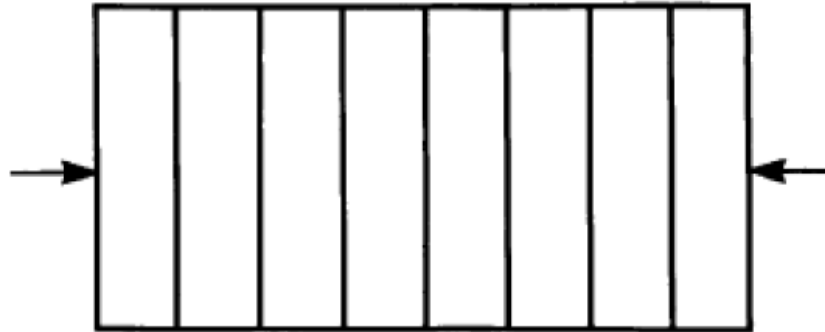

The structural explanation is that the row of books has zero tensile capacity. Therefore the ‘beam’ of books cannot even carry its self weight. To overcome this we provide an external initial stress (the prestress) which compresses the books together. Now they can only separate if the tensile stress induced by the self weight of the books is greater than the compressive prestress introduced.

Concrete

Concrete is very strong in compression but weak in tension. In an ordinary concrete beam the tensile stress at the bottom:

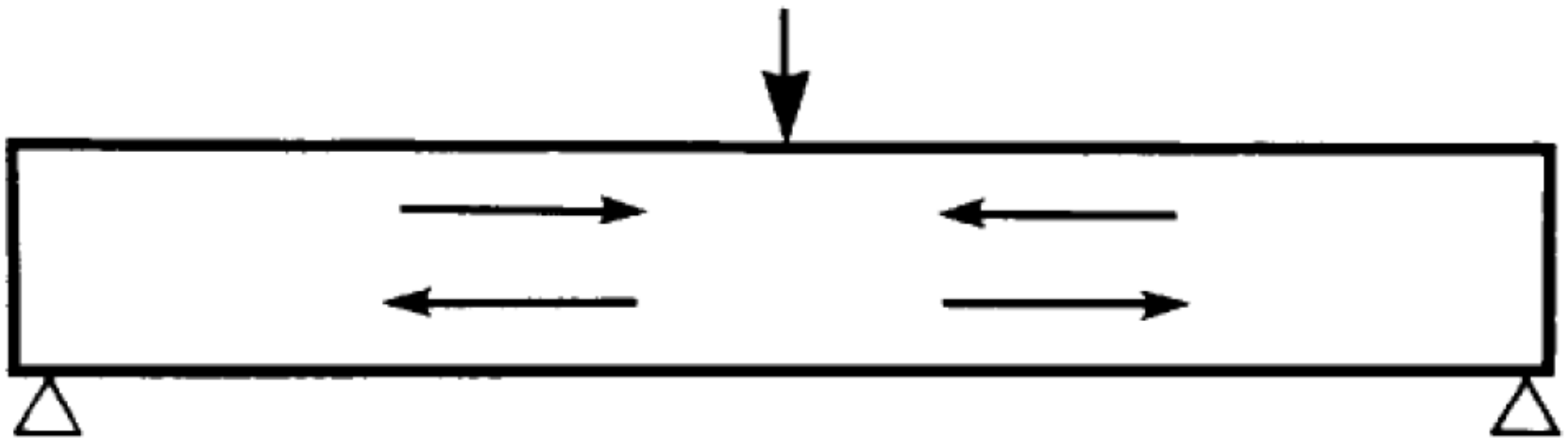

are taken by standard steel reinforcement:

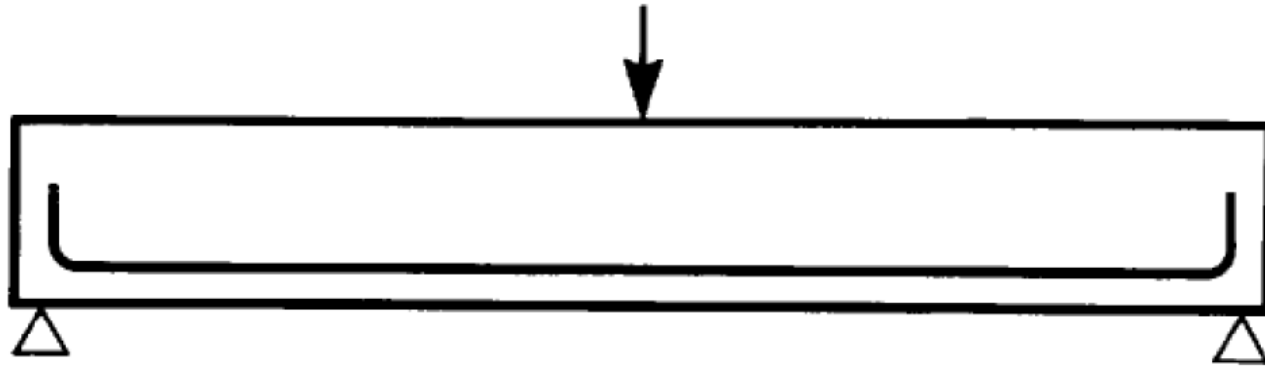

But we still get cracking, which is due to both bending and shear:

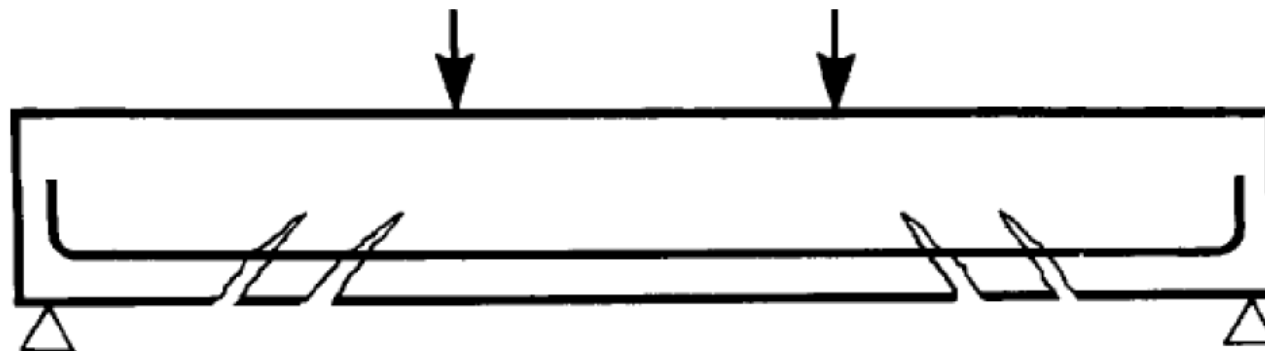

In prestressed concrete, because the prestressing keeps the concrete in compression, no cracking occurs. This is often preferable where durability is a concern.

(a) Reinforced concrete cracked under load.

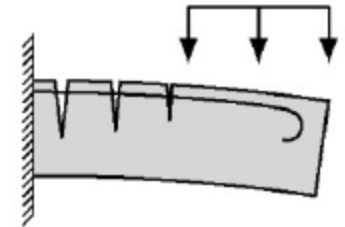
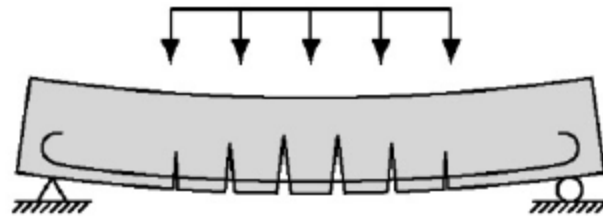

(b) Post-tensioned concrete before loading.

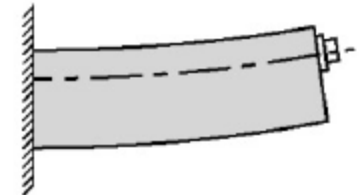
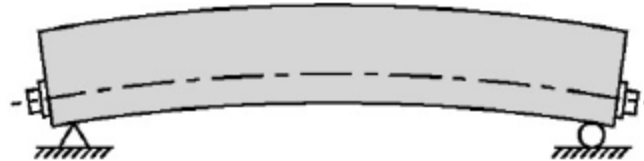

(c) Post-tensioned concrete after loading.

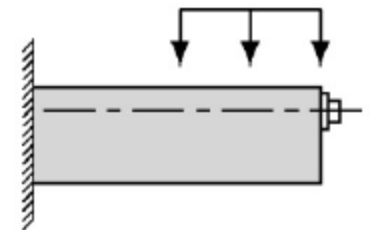
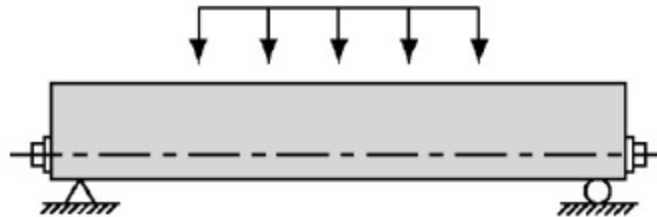

Simply Supported Beam

Cantilever Beam

Figure 1.2 - Comparison of Reinforced and Prestressed Concrete Beams

1.3 Advantages of Prestressed Concrete

The main advantages of prestressed concrete (PSC) are:

Smaller Section Sizes

Since PSC uses the whole concrete section, the second moment of area is big, so the section is stiffer:

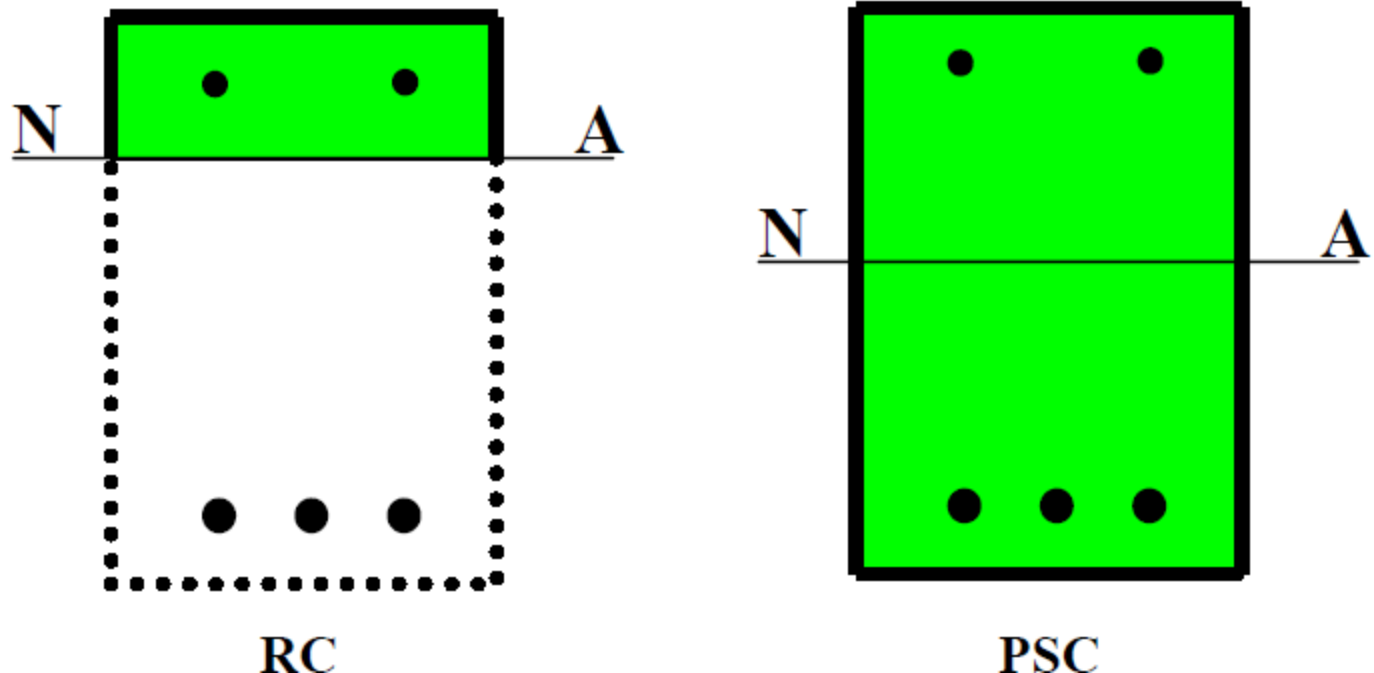

Increased Spans

The smaller section size reduces self weight. Hence a given section can span further with prestressed concrete than it can with ordinary reinforced concrete.

Durability

Since the entire section remains in compression, no cracking of the concrete can occur and hence there is little penetration of the cover. This greatly improves the long-term durability of structures, especially bridges and also means that concrete tanks can be made as watertight as steel tanks, with far greater durability.

1.4 Materials

Concrete

The main factors for concrete used in PSC are:

- Ordinary portland cement-based concrete is used but strength usually greater than 50 N/mm^2 ;
- A high early strength is required to enable quicker application of prestress;
- A larger elastic modulus is needed to reduce the shortening of the member;
- A mix that reduces creep of the concrete to minimize losses of prestress;

Steel

The steel used for prestressing has a nominal yield strength of between 1550 to 1800 N/mm². The different forms the steel may take are:

- Wires: individually drawn wires of 7 mm diameter;
- Strands: a collection of wires (usually 7) wound together and thus having a diameter that is different to its area;
- Tendon: A collection of strands encased in a duct – only used in post-tensioning;
- Bar: a specially formed bar of high strength steel of greater than 20 mm diameter.

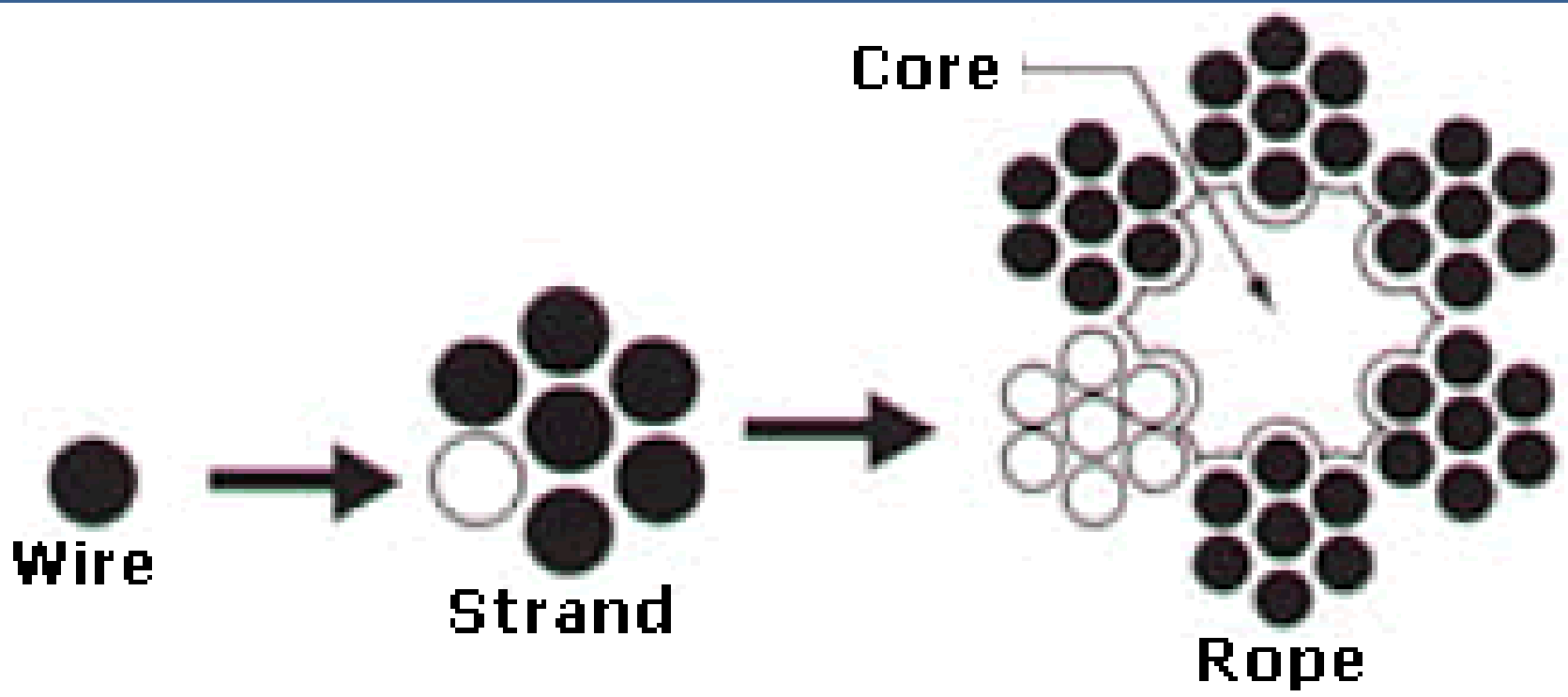

Cable
Tendon

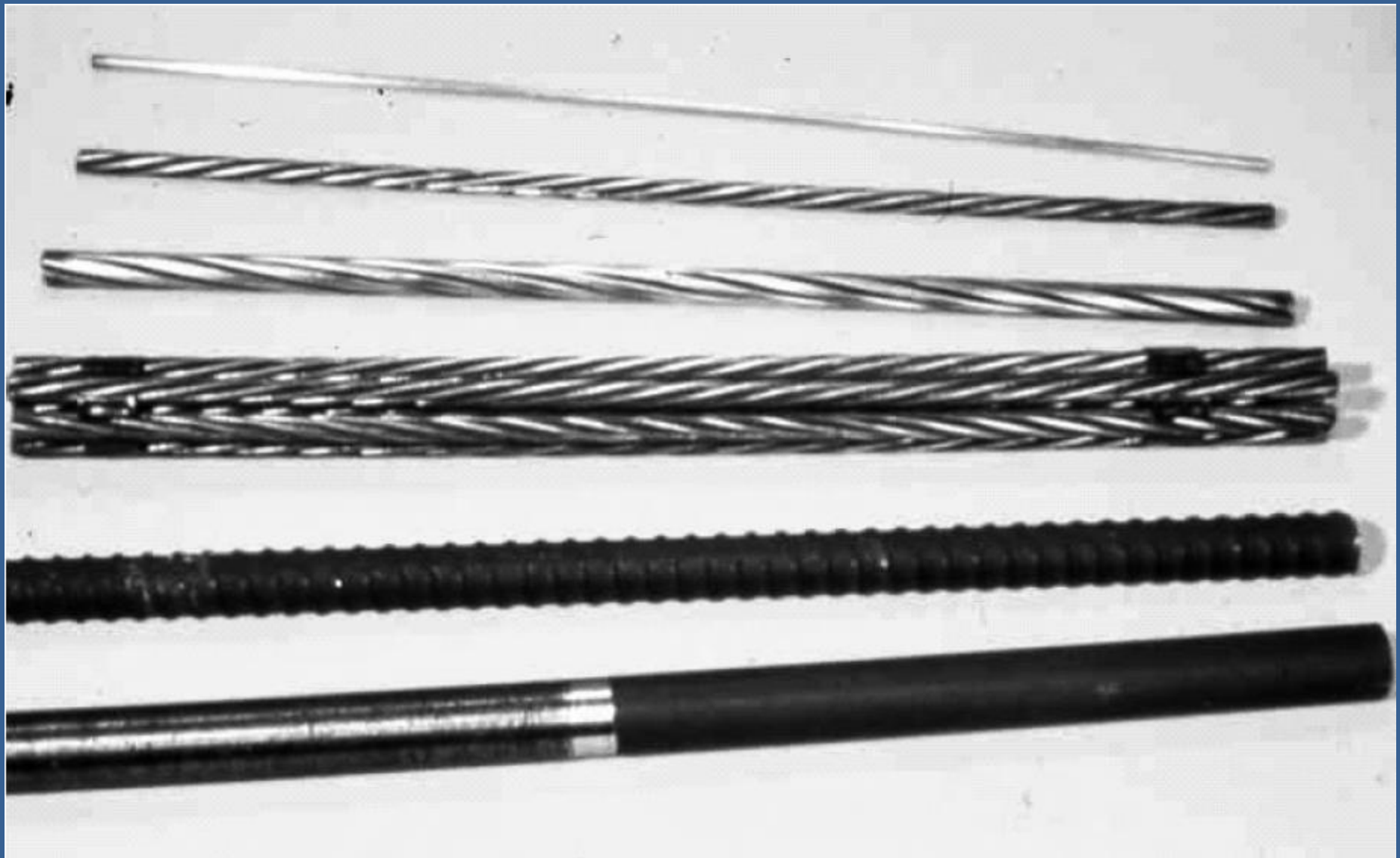

		Nominal diameter (mm)	Nominal area (mm ²)	Nominal mass (kg/m)	Yield strength (N/mm ²)	Tensile strength (N/mm ²)	Minimum breaking load (kN)	Modulus of elasticity (kN/mm ²)	Relaxation ¹ (class 2 or low relaxation)
7-wire strand low-relaxation									
13 mm (0.5")	Euronorm 138-79, or BS 5896: 1980, Super	12.9	100	0.785	1580	1860	186	195	2.5%
	Euronorm 138-79, or BS 5896: 1980, Standard	12.5	93	0.73	1500	1770	164	195	2.5%
	Euronorm 138-79, or BS 5896: 1980, Drawn	12.7	112	0.89	1580	1860	209	195	2.5%
	<u>ASTM A416-85, Grade 270</u>	12.7	98.7	0.775	1670	1860	183.7	195	2.5%
15 mm (0.6")	Euronorm 138-79, or BS 5896: 1980, Super	15.7	150	1.18	1500	1770	265	195	2.5%
	Euronorm 138-79, or BS 5896: 1980, Standard	15.2	139	1.09	1420	1670	232	195	2.5%
	Euronorm 138-79, or BS 5896: 1980, Drawn	15.2	165	1.295	1550	1820	300	195	2.5%
	<u>ASTM A416-85, Grade 270</u>	15.2	140	1.10	1670	1860	260.7	195	2.5%
Stress bars									
20 mm	BS 4486: 1980	20	314	2.39	835	1030	323	170/205	3.5%
25 mm	BS 4486: 1980	25	491	3.9	835	1030	505	170/205	3.5%
32 mm	BS 4486: 1980	32	804	6.66	835	1030	828	170/205	3.5%
40 mm	BS 4486: 1980	40	1257	10	835	1030	1300	170/205	3.5%
50 mm	BS 4486: 1980	50	1963	16.02	835	1030	2022	170/205	3.5%
Cold-drawn wire									
7 mm	BS 5896: 1980	7	38.5	302	1300	1570	60.4	205	2.5%
	BS 5896: 1980				1390	1670	64.3	205	2.5%
5 mm	BS 5896: 1980	5	19.6	154	1390	1670	32.7	205	2.5%
	BS 5896: 1980				1470	1770	34.7	205	2.5%

1.5 Methods of Prestressing

There are two methods of prestressing:

- Pre-tensioning: Apply prestress to steel strands *before* casting concrete;
- Post-tensioning: Apply prestress to steel tendons *after* casting concrete.

Pre-tensioning

This is the most common form for precast sections. In Stage 1 the wires or strands are stressed; in Stage 2 the concrete is cast around the stressed wires/strands; and in Stage 3 the prestress is *transferred* from the external anchorages to the concrete, once it has sufficient strength:

- [Video](#)
- [Video](#)

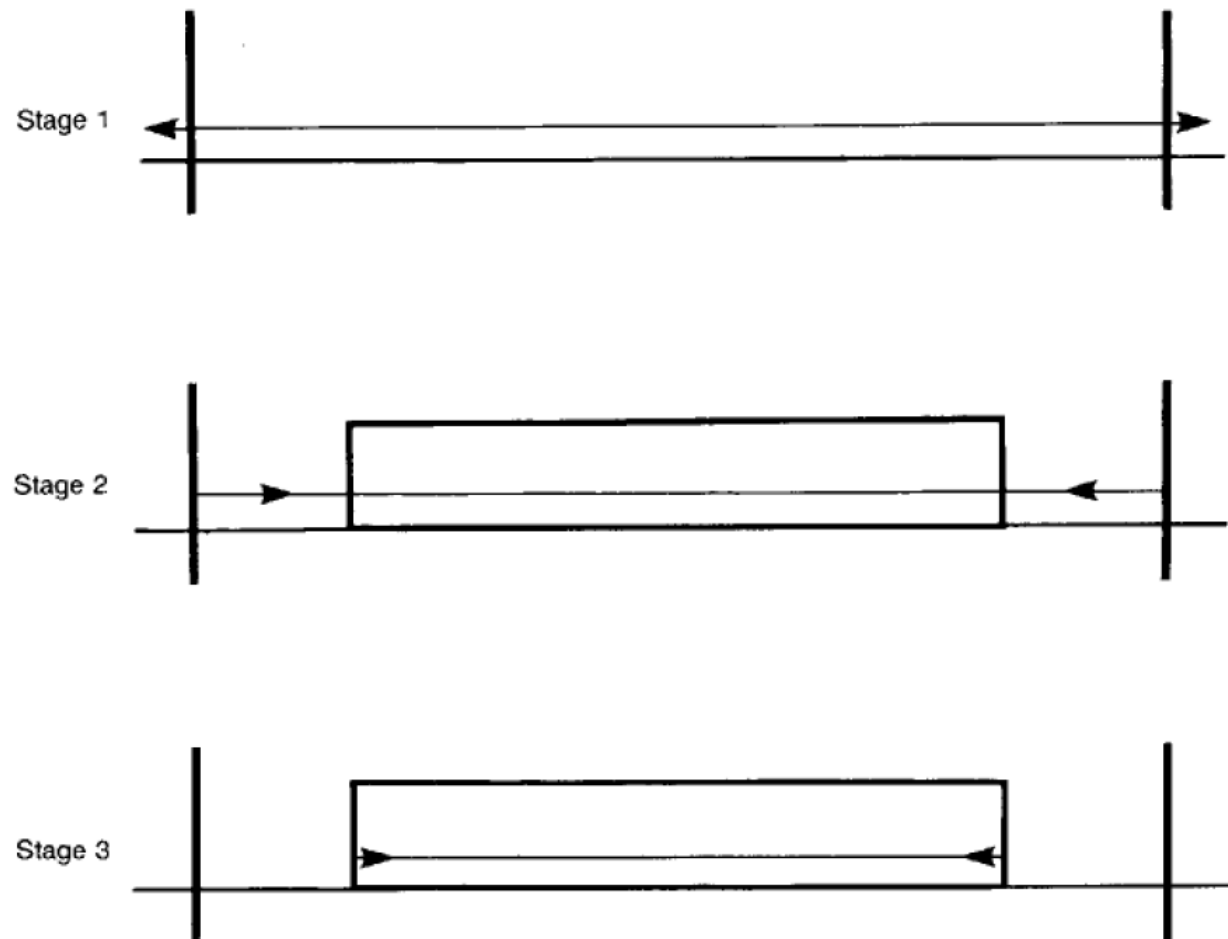

In pre-tensioned members, the strand is directly bonded to the concrete cast around it. Therefore, at the ends of the member, there is a transmission length where the strand force is transferred to the concrete through the bond:

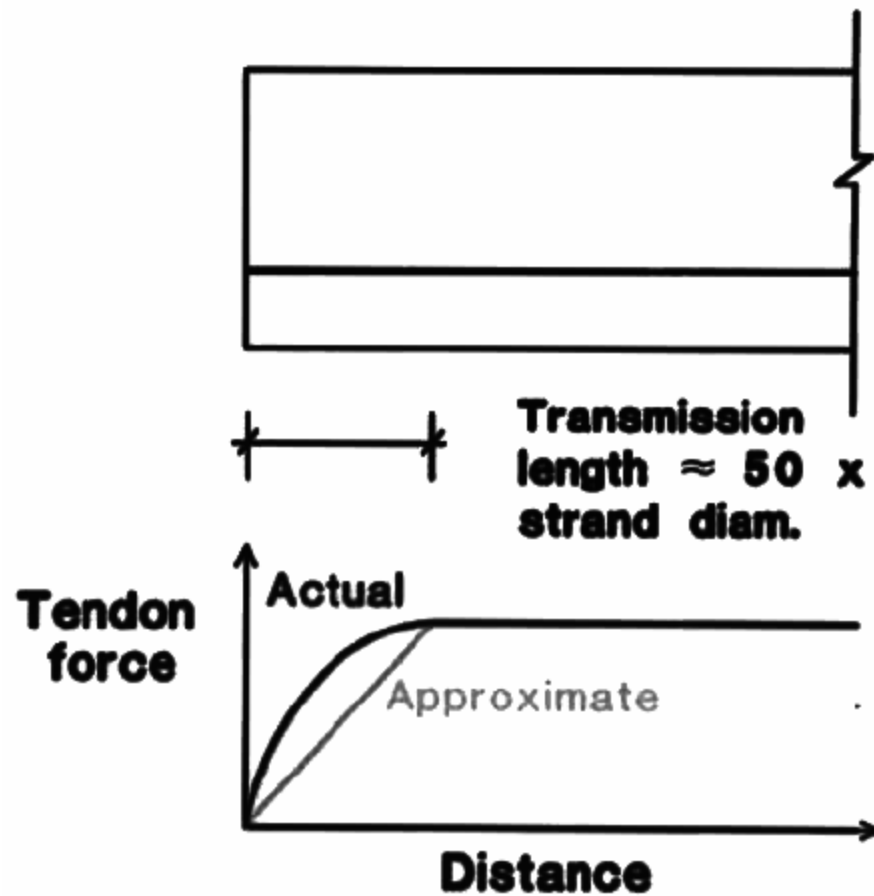

Post-tensioned

In this method, the concrete has already set but has ducts cast into it. The strands or tendons are fed through the ducts (Stage 1) then tensioned (Stage 2) and then anchored to the concrete (Stage 3):

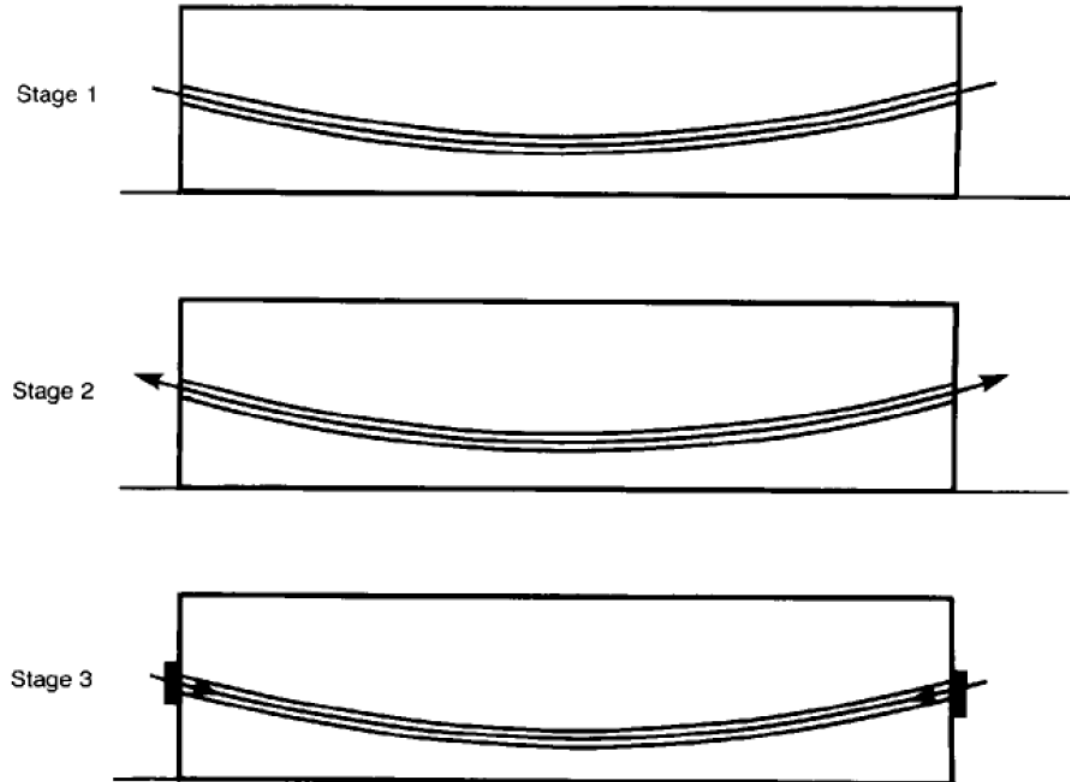

The anchorages to post-tensioned members must distribute a large load to the concrete, and must resist bursting forces as a result. A lot of ordinary reinforcement is often necessary.

- [video](#)

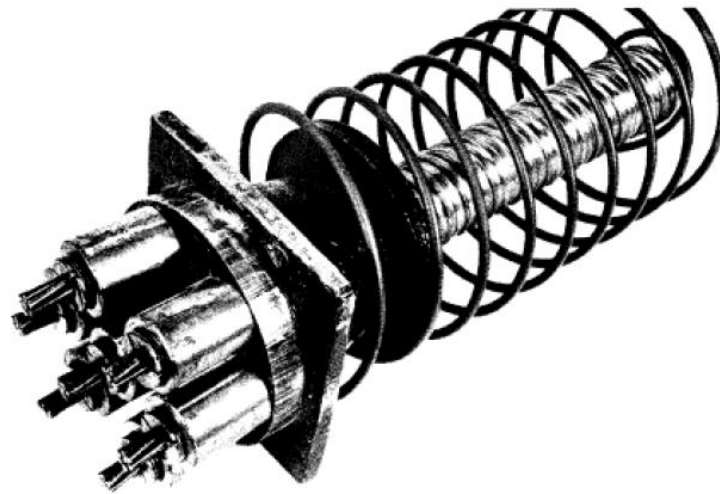

And the end of a post-tensioned member has reinforcement such as:

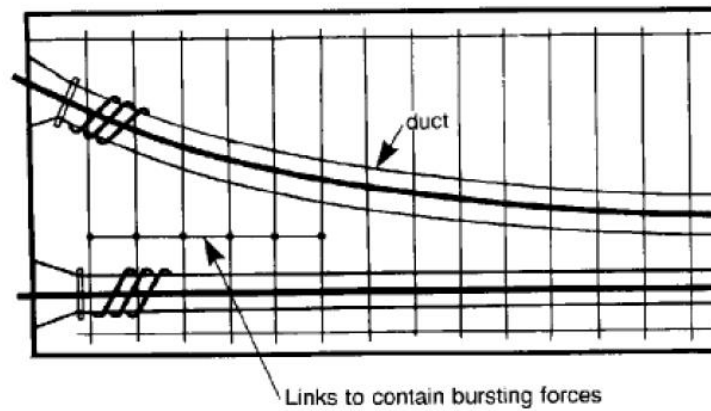

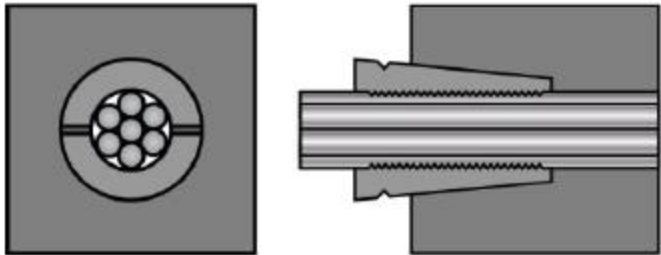

End View

Section

2-Part Wedge
(3-part wedges also available)

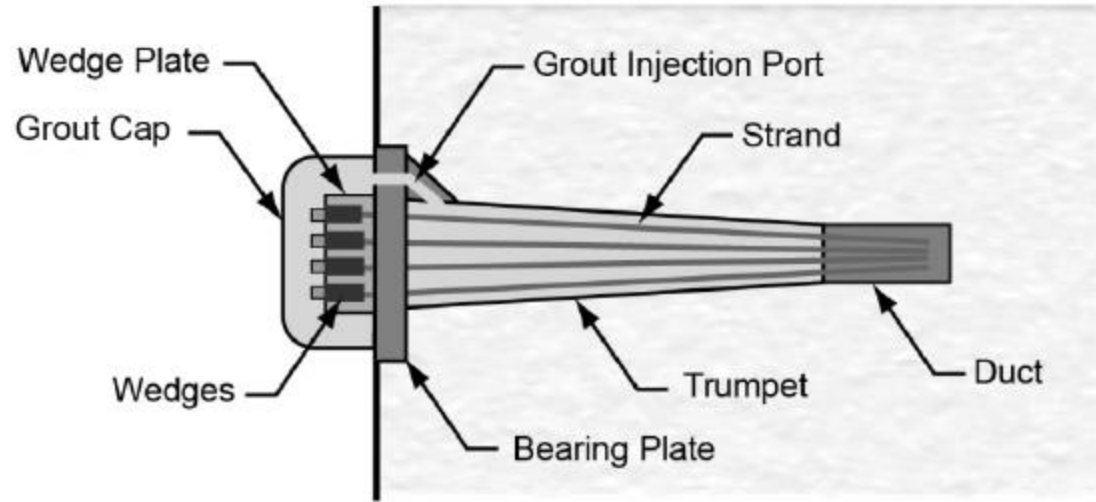

Normal Anchorage
(Plate Anchorage Shown)

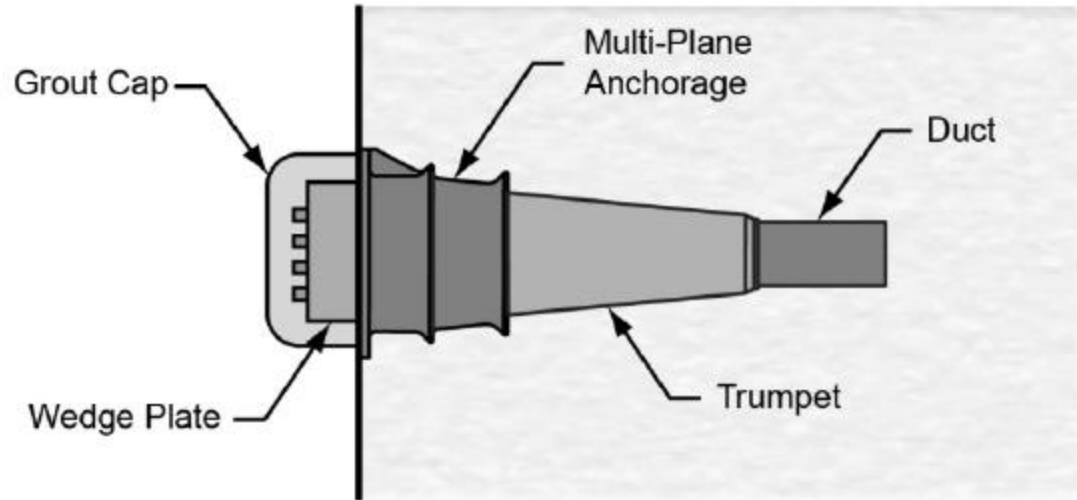

Special Anchorage
(Multi-Plane Anchorage Shown)





[KMA Video](#)
[Video](#)

[Video](#) (Chinese)



See model

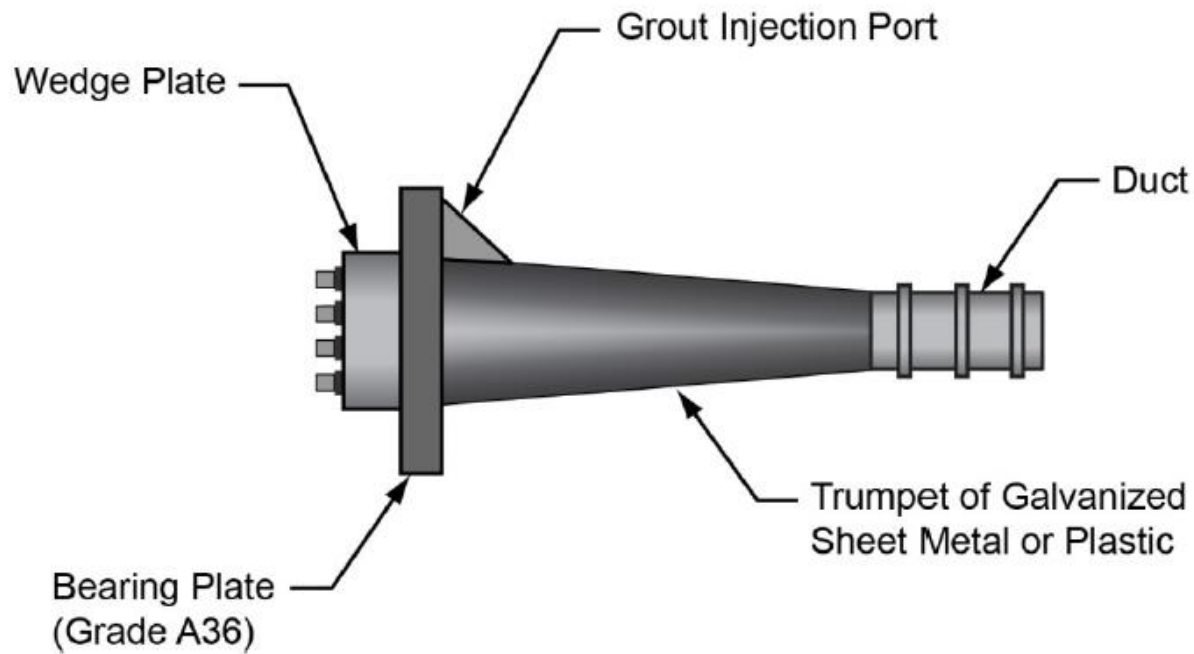

Figure 2.1 - Basic Bearing Plate Anchorage System

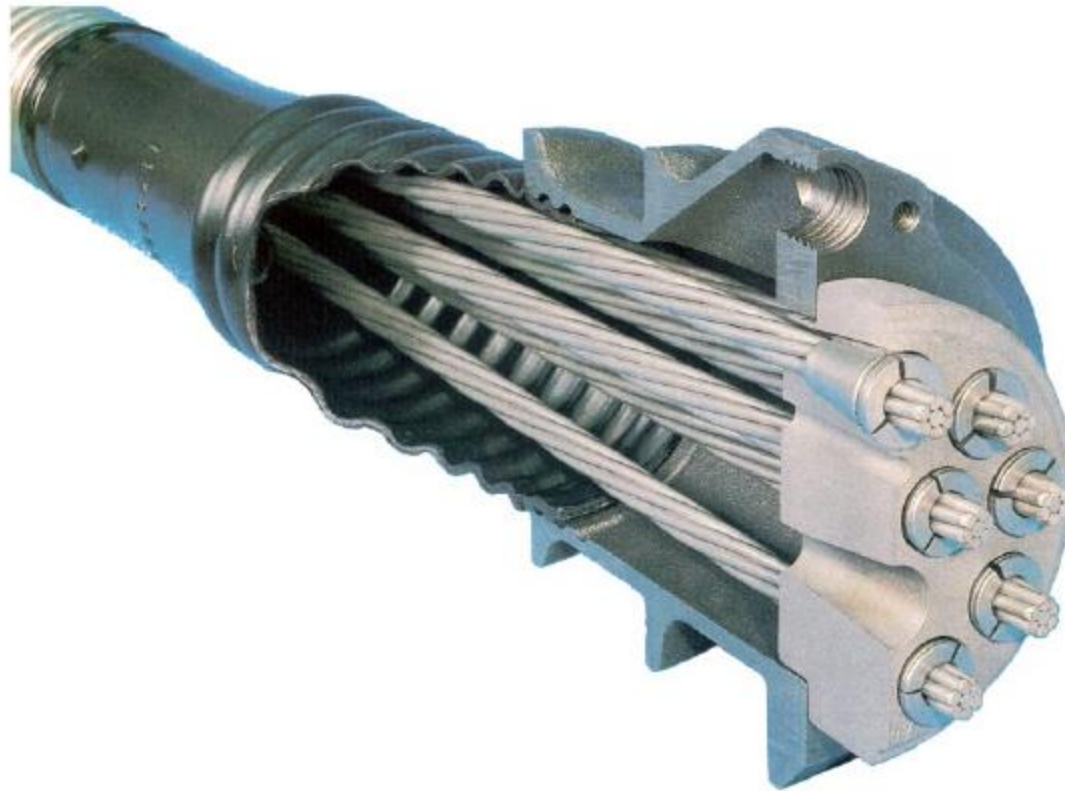

Figure 2.2 - Multi-Plane Anchorage System (Courtesy of VSL)



Figure 2.3 - Anchorage System for Flat Duct Tendon (Courtesy of DSI)



Figure 2.6 - Corrugated Metal Duct



Figure 2.7 - Corrugated Plastic Duct

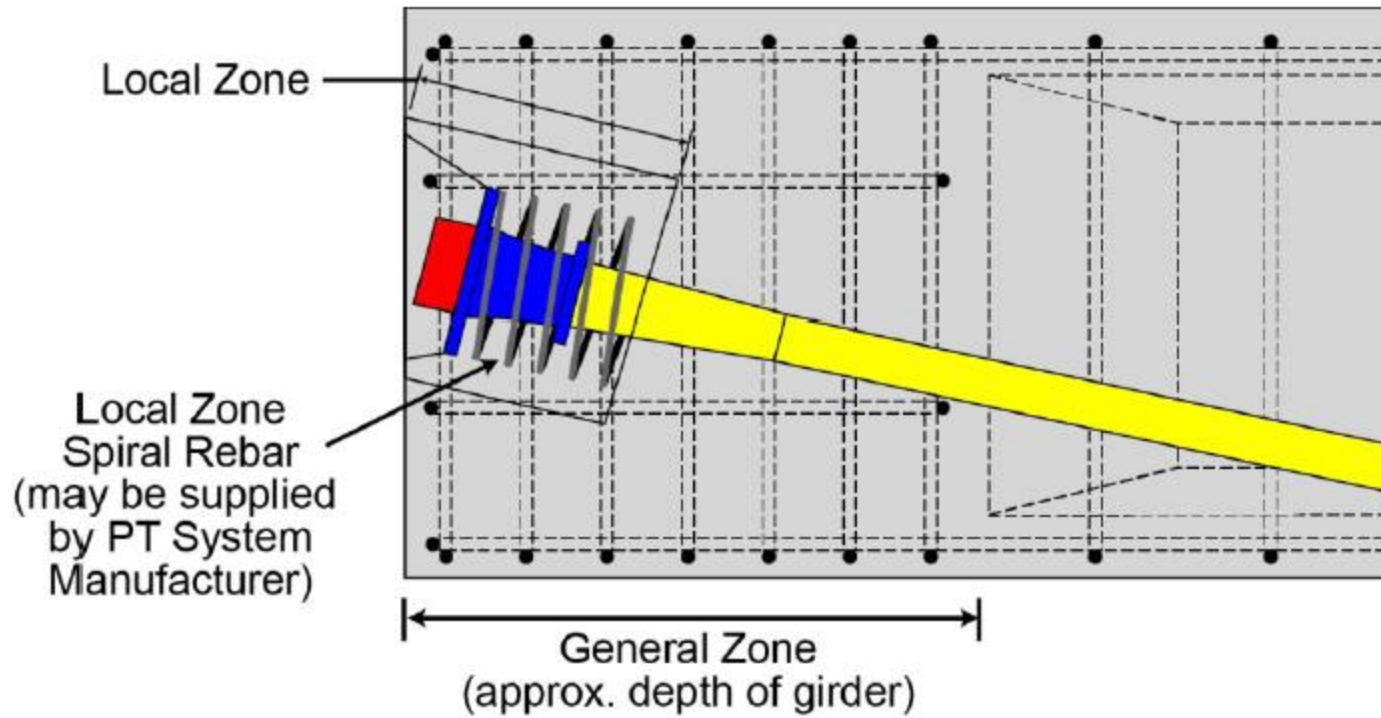

Figure 3.13 - General and Local Anchor Zone in End of I-Girder

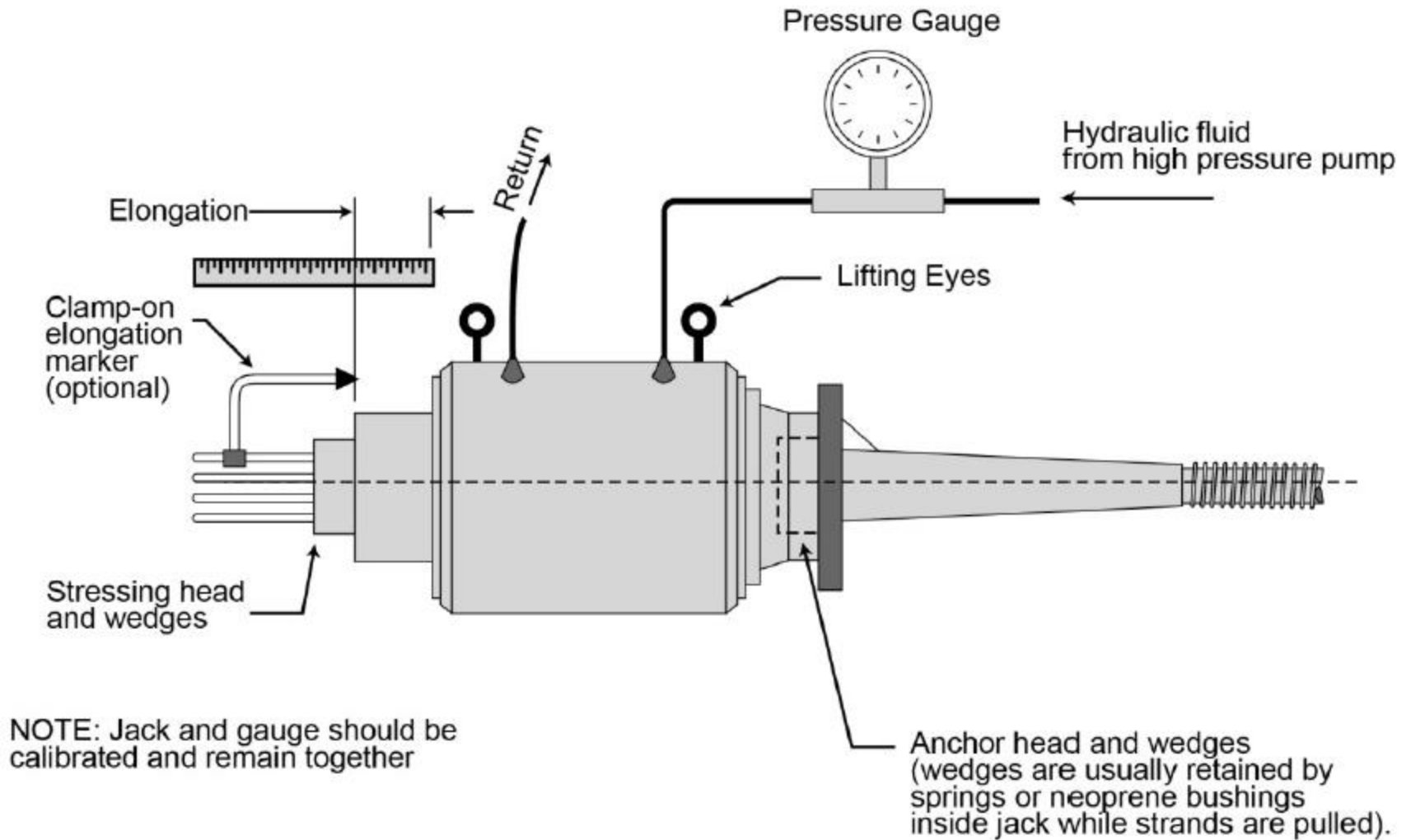

Figure 3.28 - Typical Multi-Strand, Center Hole, Stressing Jack

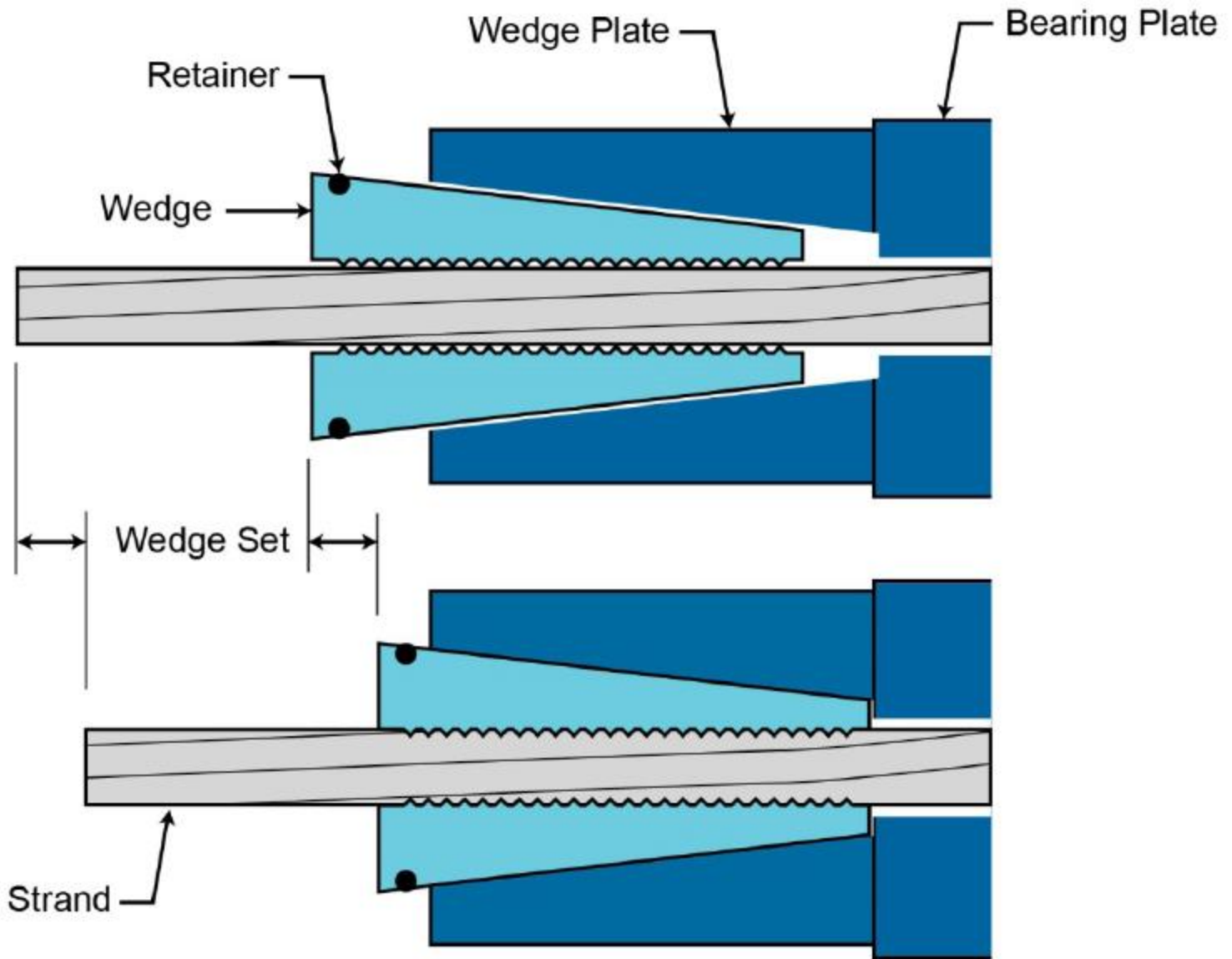
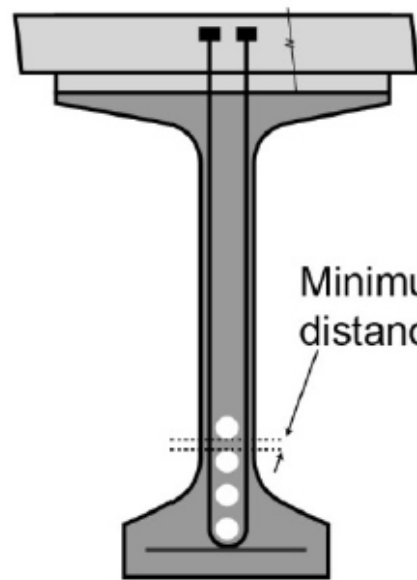
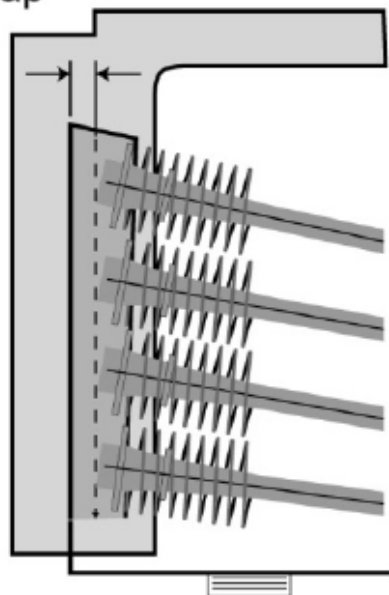
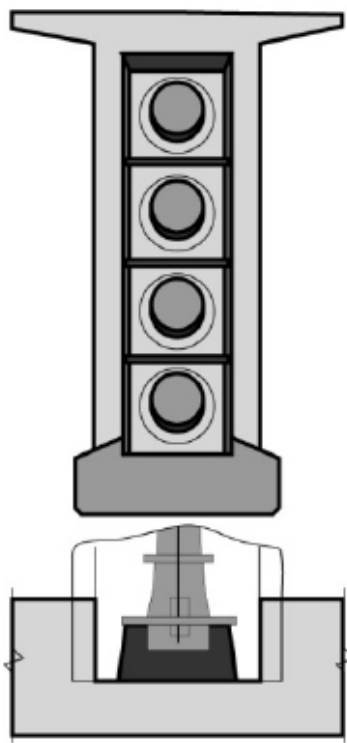

Figure 3.34 - Anchor Set or Wedge Set

Minimum 1-1/2"
over grout cap



Minimum clearance
distance as per AASHTO

- Four levels of protection provided by
- Grout
 - Plastic cap
 - Pour-back material
 - Encasement by diaphragm

Figure 5.6 – Anchor Protection Details at End Anchorages

Steps of post-tensioned PC girder bridge construction

- Preparation of casting bed
- Preparation of reinforcement cage, place tendon duct with tendon in it
- Place end bearing plate
- Place side form-work and casting (followed by curing), concrete gains target strength
- Starting prestressing tendon one by one (may be from both end), still on bed
- Check slip
- Grouting,
- Lift on temporary support, casting the end to cover the anchors
- Lift on to bearing pad on bent beam
- Cast the deck slab on the PC girders
- Cast barriers

- TRH [video](#)

1.6 Uses of Prestressed Concrete

There are a huge number of uses:

- Railway Sleepers;
- Communications poles;
- Pre-tensioned precast “hollowcore” slabs;
- Pre-tensioned Precast Double T units - for very long spans (e.g., 16 m span for car parks);
- Pre-tensioned precast inverted T beam for short-span bridges;
- Pre-tensioned precast PSC piles;
- Pre-tensioned precast portal frame units;
- Post-tensioned ribbed slab;
- In-situ balanced cantilever construction - post-tensioned PSC;
- This is “glued segmental” construction;
- Precast segments are joined by post-tensioning;
- PSC tank - precast segments post-tensioned together on site. Tendons around circumference of tank;
- Barges;
- And many more.

Cast in situ or precast ?

- Both



Figure 1.6 - Cast-In-Place Post-Tensioned Construction in California



Figure 1.7 - Spliced Haunched I-Girder of Main Span Unit

Prestressing in bentcap/hammerhead

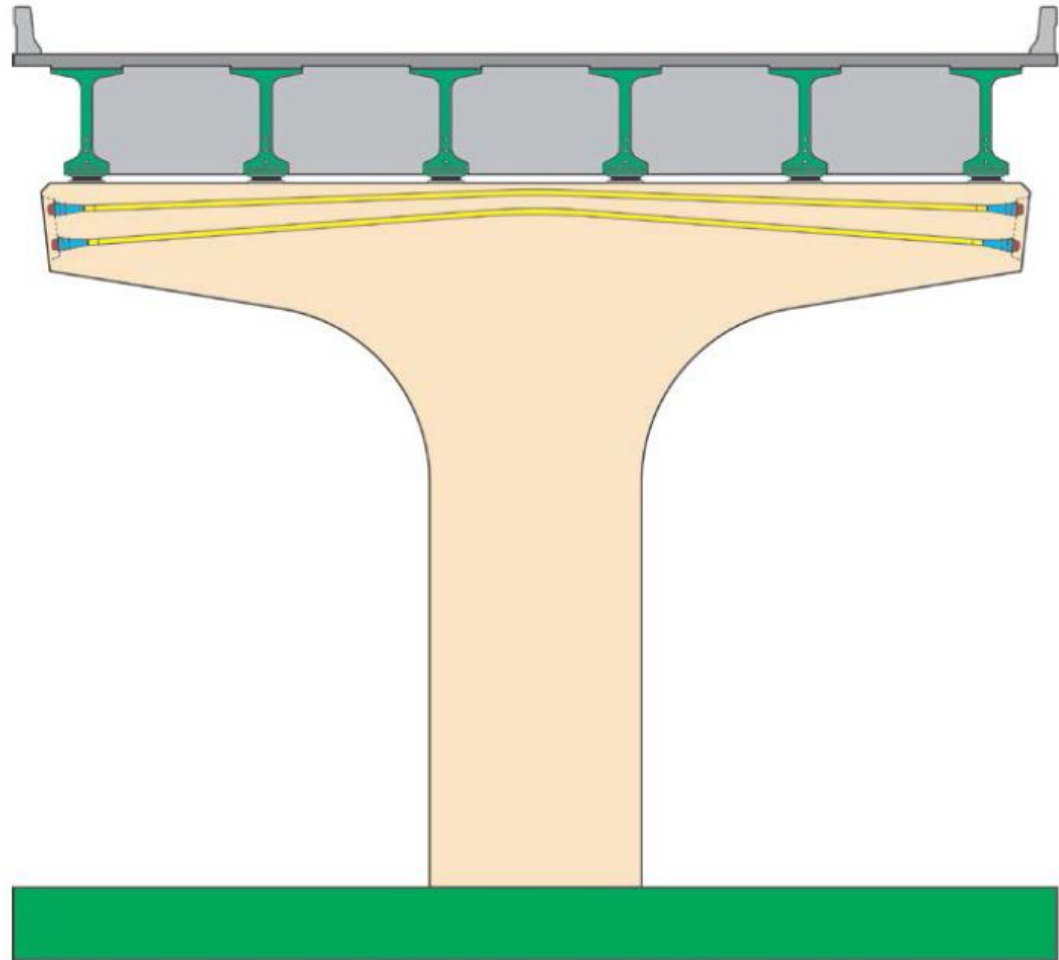

Figure 1.29 - Post-Tensioning in Hammerhead Piers

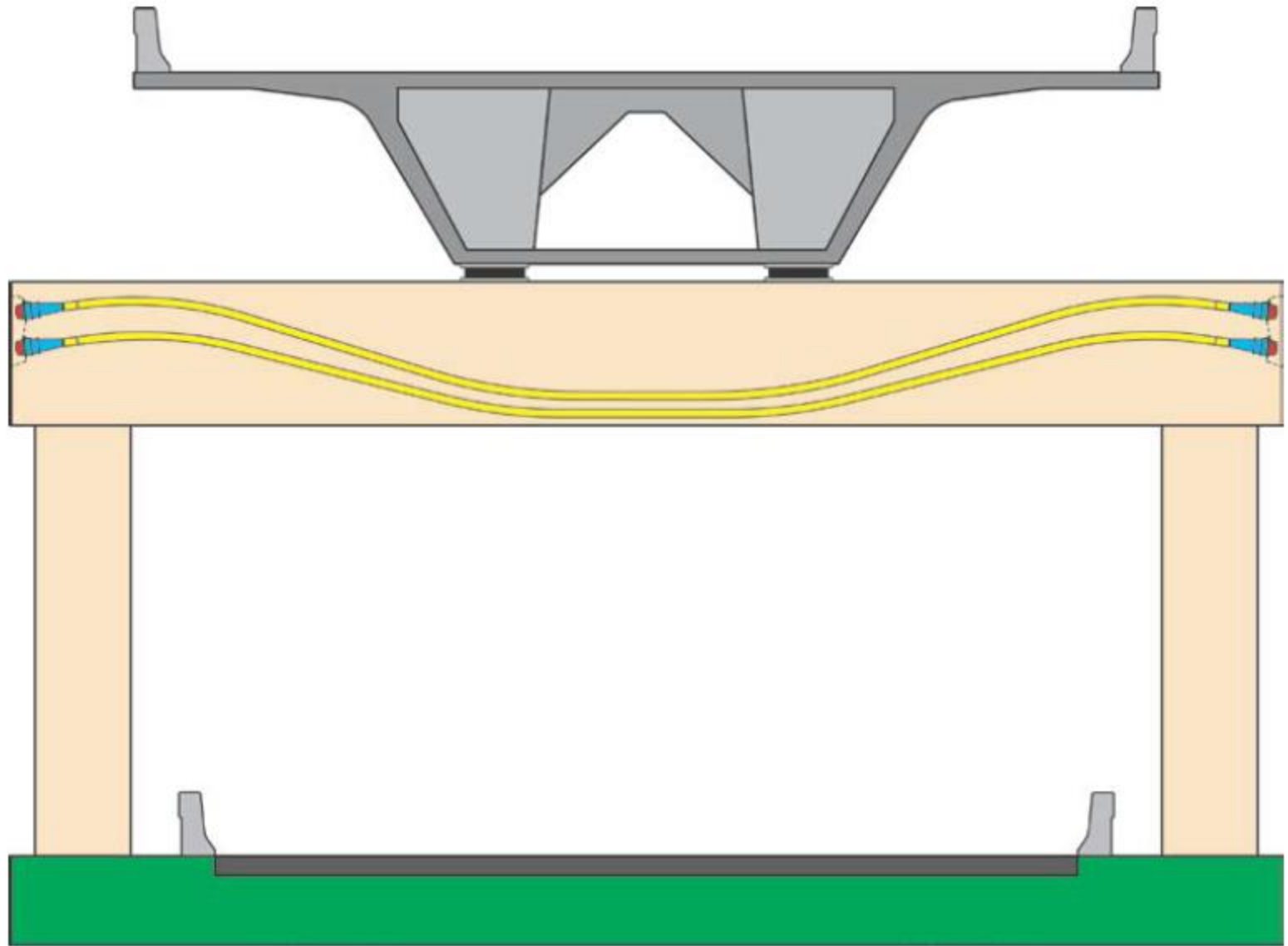

Figure 1.30 - Post-Tensioning in Straddle Bents

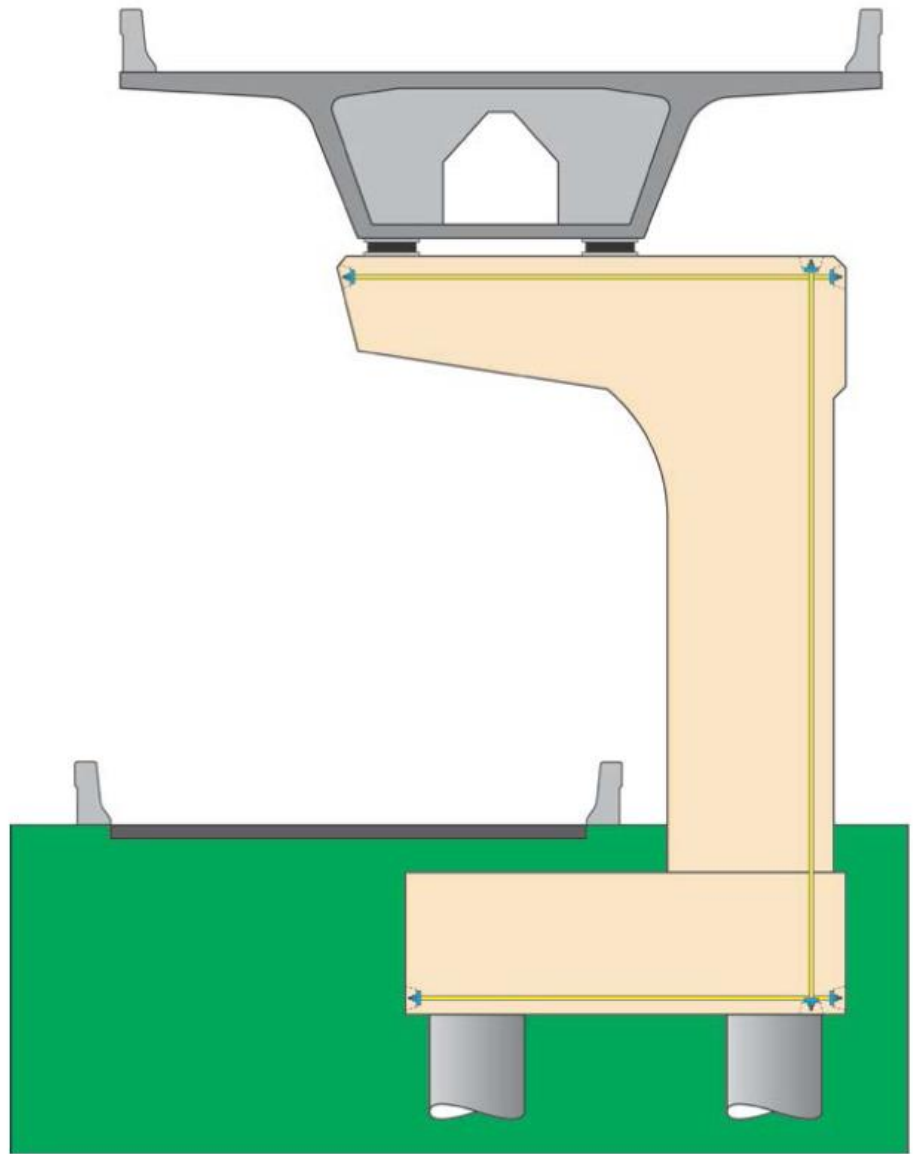

Figure 1.31 - Post-Tensioning in Cantilever Piers

LRFD method

LRFD Equation as Used in AASHTO Specifications

$$\sum \eta_i \gamma_i Q_i \leq \phi R_n = R_r$$

- η_i = Load Modification Factor
- Modification factors shown at the right

The η_i factors (A1.3.2.1) represent a first attempt at codifying the influence of ductility, redundancy and operational importance on structure performance. For loads for which a maximum value of γ_i is appropriate:

$$\eta_k = \eta_D \eta_R \eta_I \geq 0.95 \quad (\text{Eq. 4-34}) \text{ (A1.3.2.1-2)}$$

For loads for which a minimum value of γ_i is appropriate:

$$\eta_k = \frac{1}{\eta_D \eta_R \eta_I} \leq 1.00 \quad (\text{Eq. 4-35}) \text{ (A1.3.2.1-3)}$$

Due to a lack of precise information, the effect of these modifiers has been judged to range between ± 5 percent when accumulated geometrically. With time, it is hoped that improved quantification of ductility, redundancy and operational importance, and their interaction and system synergy, can be attained to better account for these factors in design.

For design at the Strength Limit State, values of η_i range as follows:

- Ductility - η_D
 - $\eta_D \leq 1.05$ for non-ductile components and connections
 - $\eta_D = 1.00$ for conventional designs and details
 - $\eta_D \geq 0.95$ for components and connections for which additional ductility-enhancing measures are specified
- Redundancy - η_R
 - $\eta_R \leq 1.05$ for non-redundant components and connections
 - $\eta_R = 1.00$ for conventional levels of redundancy
 - $\eta_R \geq 0.95$ for exceptional levels of redundancy
- Operational Importance - η_I
 - $\eta_I \leq 1.05$ for important structures
 - $\eta_I = 1.00$ for typical structures
 - $\eta_I \geq 0.95$ for relatively less important structures

Classification of operational importance should be based on social, survival and/or security or defense requirements. With respect to seismic design, bridges classified as critical or essential as described in Table 4-8, should be considered operationally important structures.

For design at the Service Limit State, $\eta_D = \eta_R = \eta_I = 1.0$.

Limit States and Loads

- For a structure to be sound, Resistance \geq Effect of the Loads
- Definition of Limit State
 - A condition beyond which a structural component, such as a foundation or other bridge component, ceases to fulfill the function for which it was designed
- Strength Limit States
 - Involve the total or partial collapse of the structure
 - Include bearing capacity failure, sliding and overall instability
- Service Limit States
 - Affect the function of the structure under regular service conditions
 - Include excessive settlement, excessive lateral deflections, and structural deterioration of the foundation or excessive vibration

1.3.2—Limit States

1.3.2.1—General

Each component and connection shall satisfy Eq. 1.3.2.1-1 for each limit state, unless otherwise specified. For service and extreme event limit states, resistance factors shall be taken as 1.0, except for bolts, for which the provisions of Article 6.5.5 shall apply, and for concrete columns in Seismic Zones 2, 3, and 4, for which the provisions of Articles 5.10.11.3 and 5.10.11.4.1b shall apply. All limit states shall be considered of equal importance.

$$\sum \eta_i \gamma_i Q_i \leq \phi R_n = R_r \quad (1.3.2.1-1)$$

in which:

For loads for which a maximum value of γ_i is appropriate:

$$\eta_i = \eta_D \eta_R \eta_I \geq 0.95 \quad (1.3.2.1-2)$$

For loads for which a minimum value of γ_i is appropriate:

$$\eta_i = \frac{1}{\eta_D \eta_R \eta_I} \leq 1.0 \quad (1.3.2.1-3)$$

where:

γ_i = load factor: a statistically based multiplier applied to force effects

ϕ = resistance factor: a statistically based multiplier applied to nominal resistance, as specified in Sections 5, 6, 7, 8, 10, 11, and 12

η_i = load modifier: a factor relating to ductility, redundancy, and operational classification

η_D = a factor relating to ductility, as specified in Article 1.3.3

η_R = a factor relating to redundancy as specified in Article 1.3.4

η_I = a factor relating to operational classification as specified in Article 1.3.5

Q_i = force effect

R_n = nominal resistance

R_r = factored resistance: ϕR_n

3.6.1.2—Design Vehicular Live Load

3.6.1.2.1—General

Vehicular live loading on the roadways of bridges or incidental structures, designated HL-93, shall consist of a combination of the:

- Design truck or design tandem, and
- Design lane load.

Except as modified in Article 3.6.1.3.1, each design lane under consideration shall be occupied by either the design truck or tandem, coincident with the lane load, where applicable. The loads shall be assumed to occupy 10.0 ft transversely within a design lane.

3.6.1.2.2—Design Truck

The weights and spacings of axles and wheels for the design truck shall be as specified in Figure 3.6.1.2.2-1. A dynamic load allowance shall be considered as specified in Article 3.6.2.

Except as specified in Articles 3.6.1.3.1 and 3.6.1.4.1, the spacing between the two 32.0-kip axles shall be varied between 14.0 ft and 30.0 ft to produce extreme force effects.

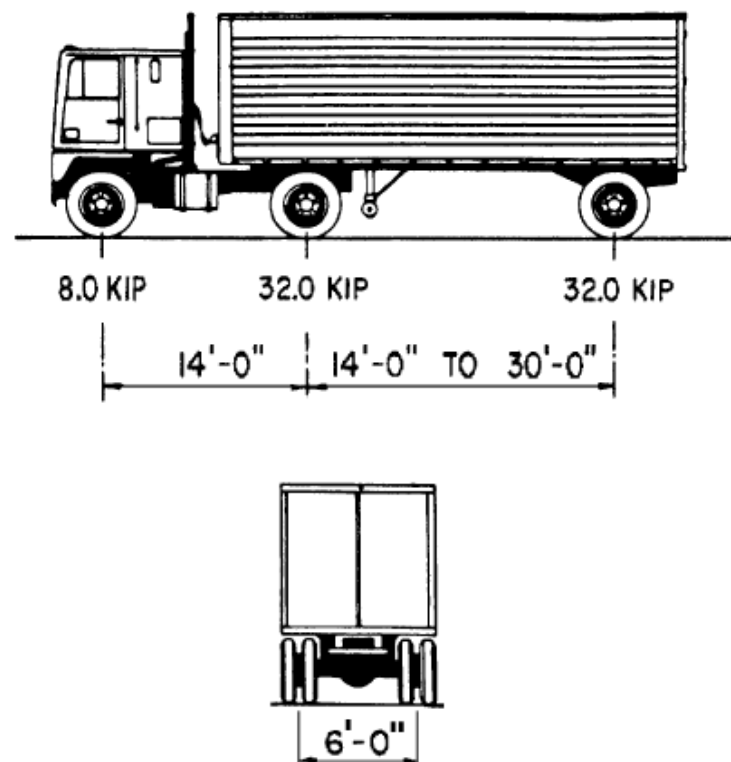

Figure 3.6.1.2.2-1—Characteristics of the Design Truck

3.6.1.2.3—Design Tandem

The design tandem shall consist of a pair of 25.0-kip axles spaced 4.0 ft apart. The transverse spacing of wheels shall be taken as 6.0 ft. A dynamic load allowance shall be considered as specified in Article 3.6.2.

3.6.1.2.4—Design Lane Load

The design lane load shall consist of a load of 0.64 klf uniformly distributed in the longitudinal direction. Transversely, the design lane load shall be assumed to be uniformly distributed over a 10.0-ft width. The force effects from the design lane load shall not be subject to a dynamic load allowance.

Basic LRFD Design Live Load HL-93 -- (Article 3.6.1.2.1)

◆ Design Truck: ⇒

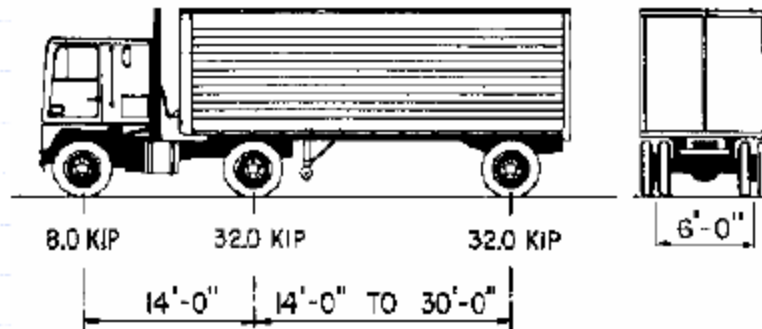

or

◆ Design Tandem:
Pair of 25.0 KIP axles
spaced 4.0 FT apart

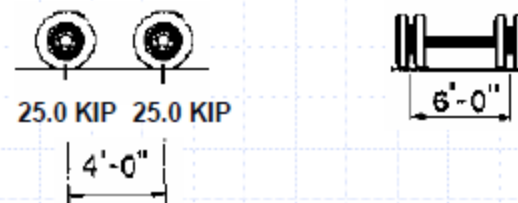

or

superimposed on

+

◆ Design Lane Load 0.64 KLF
uniformly distributed load

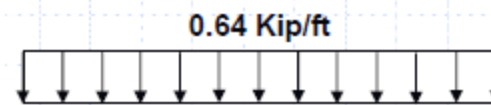

3.6.1.3—Application of Design Vehicular Live Loads

3.6.1.3.1—General

Unless otherwise specified, the extreme force effect shall be taken as the larger of the following:

- The effect of the design tandem combined with the effect of the design lane load, or
 - The effect of one design truck with the variable axle spacing specified in Article 3.6.1.2.2, combined with the effect of the design lane load, and
-
- For negative moment between points of contraflexure under a uniform load on all spans, and reaction at interior piers only, 90 percent of the effect of two design trucks spaced a minimum of 50.0 ft between the lead axle of one truck and the rear axle of the other truck, combined with 90 percent of the effect of the design lane load. The distance between the 32.0-kip axles of each truck shall be taken as 14.0 ft. The two design trucks shall be placed in adjacent spans to produce maximum force effects.

LRFD Negative Moment Loading (Article 3.6.1.3.1)

- ◆ For negative moment (between points of permanent-load contraflexure) & interior-pier reactions, check an additional load case:

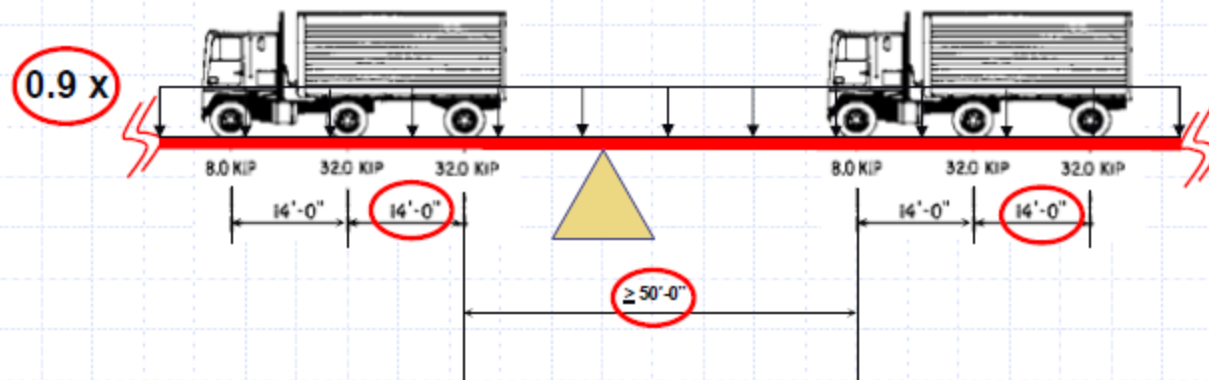

LRFD Fatigue Load (Article 3.6.1.4.1)

- ◆ Design Truck only =>
 - w/ fixed 30-ft rear-axle spacing
 - Placed in a single lane

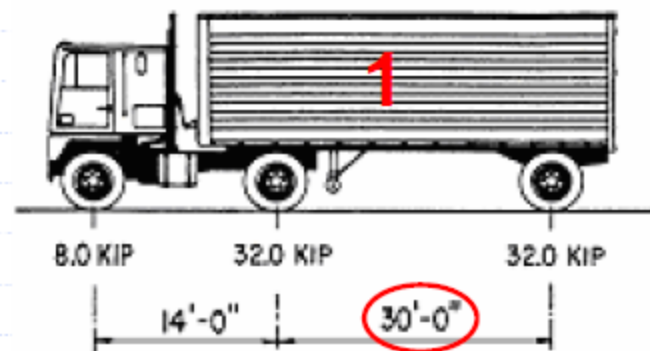

3.6.2—Dynamic Load Allowance: *IM*

3.6.2.1—General

Unless otherwise permitted in Articles 3.6.2.2 and 3.6.2.3, the static effects of the design truck or tandem, other than centrifugal and braking forces, shall be increased by the percentage specified in Table 3.6.2.1-1 for dynamic load allowance.

The factor to be applied to the static load shall be taken as: $(1 + IM/100)$.

The dynamic load allowance shall not be applied to pedestrian loads or to the design lane load.

Table 3.6.2.1-1—Dynamic Load Allowance, *IM*

Component	IM
Deck Joints—All Limit States	75%
All Other Components:	
• Fatigue and Fracture Limit State	15%
• All Other Limit States	33%

3.4—LOAD FACTORS AND COMBINATIONS

3.4.1—Load Factors and Load Combinations

The total factored force effect shall be taken as:

$$Q = \sum \eta_i \gamma_i Q_i \quad (3.4.1-1)$$

where:

- η_i = load modifier specified in Article 1.3.2
- Q_i = force effects from loads specified herein
- γ_i = load factors specified in Tables 3.4.1-1 and 3.4.1-2

- Strength I—Basic load combination relating to the normal vehicular use of the bridge without wind.
- Strength II—Load combination relating to the use of the bridge by Owner-specified special design vehicles, evaluation permit vehicles, or both without wind.
- Strength III—Load combination relating to the bridge exposed to wind velocity exceeding 55 mph.
- Strength IV—Load combination relating to very high dead load to live load force effect ratios.

- Strength V—Load combination relating to normal vehicular use of the bridge with wind of 55 mph velocity.
- Extreme Event I—Load combination including earthquake. The load factor for live load γ_{EQ} , shall be determined on a project-specific basis.
- Extreme Event II—Load combination relating to ice load, collision by vessels and vehicles, check floods, and certain hydraulic events with a reduced live load other than that which is part of the vehicular collision load, *CT*. The cases of check floods shall not be combined with *BL*, *CV*, *CT*, or *IC*.

- Service I—Load combination relating to the normal operational use of the bridge with a 55 mph wind and all loads taken at their nominal values. Also related to deflection control in buried metal structures, tunnel liner plate, and thermoplastic pipe, to control crack width in reinforced concrete structures, and for transverse analysis relating to tension in concrete segmental girders. This load combination should also be used for the investigation of slope stability.
- Service II—Load combination intended to control yielding of steel structures and slip of slip-critical connections due to vehicular live load.
- Service III—Load combination for longitudinal analysis relating to tension in prestressed concrete superstructures with the objective of crack control and to principal tension in the webs of segmental concrete girders.
- Service IV—Load combination relating only to tension in prestressed concrete columns with the objective of crack control.

- Fatigue I—Fatigue and fracture load combination related to infinite load-induced fatigue life.

- Fatigue II—Fatigue and fracture load combination related to finite load-induced fatigue life.

Table 3.4.1-2—Load Factors for Permanent Loads, γ_p

Type of Load, Foundation Type, and Method Used to Calculate Downdrag		Load Factor	
		Maximum	Minimum
<i>DC</i> : Component and Attachments		1.25	0.90
<i>DC</i> : Strength IV only		1.50	0.90
<i>DD</i> : Downdrag	Piles, α Tomlinson Method	1.4	0.25
	Piles, λ Method	1.05	0.30
	Drilled shafts, O’Neill and Reese (1999) Method	1.25	0.35
<i>DW</i> : Wearing Surfaces and Utilities		1.50	0.65
<i>EH</i> : Horizontal Earth Pressure			
• Active		1.50	0.90
• At-Rest		1.35	0.90
• <i>AEP</i> for anchored walls		1.35	N/A
<i>EL</i> : Locked-in Construction Stresses		1.00	1.00
<i>EV</i> : Vertical Earth Pressure			
• Overall Stability		1.00	N/A
• Retaining Walls and Abutments		1.35	1.00
• Rigid Buried Structure		1.30	0.90
• Rigid Frames		1.35	0.90
• Flexible Buried Structures			
○ Metal Box Culverts and Structural Plate Culverts with Deep Corrugations		1.5	0.9
○ Thermoplastic culverts		1.3	0.9
○ All others		1.95	0.9
<i>ES</i> : Earth Surcharge		1.50	0.75

- Strength I

1.25 Self + 1.50 Barr +1.50 Wear+ 1.75 Live + 1.00 Prestress

- Strength II

1.25 Self + 1.50 Barr +1.50 Wear+ 1.35 Live + 1.00 Prestress

- Strength III

1.25 Self + 1.50 Barr +1.5 Wear+ 1.40 Wind + 1.00 Prestress

- Strength IV

1.50 Self + 1.50 Barr +1.5 Wear + 1.00 Prestress

- Strength V

1.25 Self + 1.50 Barr +1.5 Wear + 1.00 Prestress +0.40 Wind
+1.00 Wind on Live

- Service I

1.0 Self + 1.0 Barr +1.0 Wear+ 1.0 Live + 1.00 Prestress +
0.3 Wind +1.0 Wind on Live

- Service II

1.0 Self + 1.0 Barr +1.0 Wear+ 1.3 Live + 1.00 Prestress

- Service III

1.0 Self + 1.0 Barr +1.0 Wear+ 0.8 Live + 1.00 Prestress

- Service IV

1.0 Self + 1.0 Barr +1.0 Wear+1.00 Prestress + 0.7 Wind

- Extreme I

1.25 Self + 1.50 Barr +1.50 Wear+ 0.5 Live + 1.00 Prestress +
1.0 Earthquake

- Extreme II

Table 3.5.1-1—Unit Weights

Material		Unit Weight (kcf)
Aluminum Alloys		0.175
Bituminous Wearing Surfaces		0.140
Cast Iron		0.450
Cinder Filling		0.060
Compacted Sand, Silt, or Clay		0.120
Concrete	Lightweight	0.110
	Sand-Lightweight	0.120
	Normal Weight with $f'_c \leq 5.0$ ksi	0.145
	Normal Weight with $5.0 < f'_c \leq 15.0$ ksi	$0.140 + 0.001 f'_c$
Loose Sand, Silt, or Gravel		0.100
Soft Clay		0.100
Rolled Gravel, Macadam, or Ballast		0.140
Steel		0.490
Stone Masonry		0.170
Wood	Hard	0.060
	Soft	0.050
Water	Fresh	0.0624
	Salt	0.0640
Item		Weight per Unit Length (klf)
Transit Rails, Ties, and Fastening per Track		0.200

Table 3.6.1.1.2-1—Multiple Presence Factors, m

Number of Loaded Lanes	Multiple Presence Factors, m
1	1.20
2	1.00
3	0.85
>3	0.65

DESIGN OF DECK

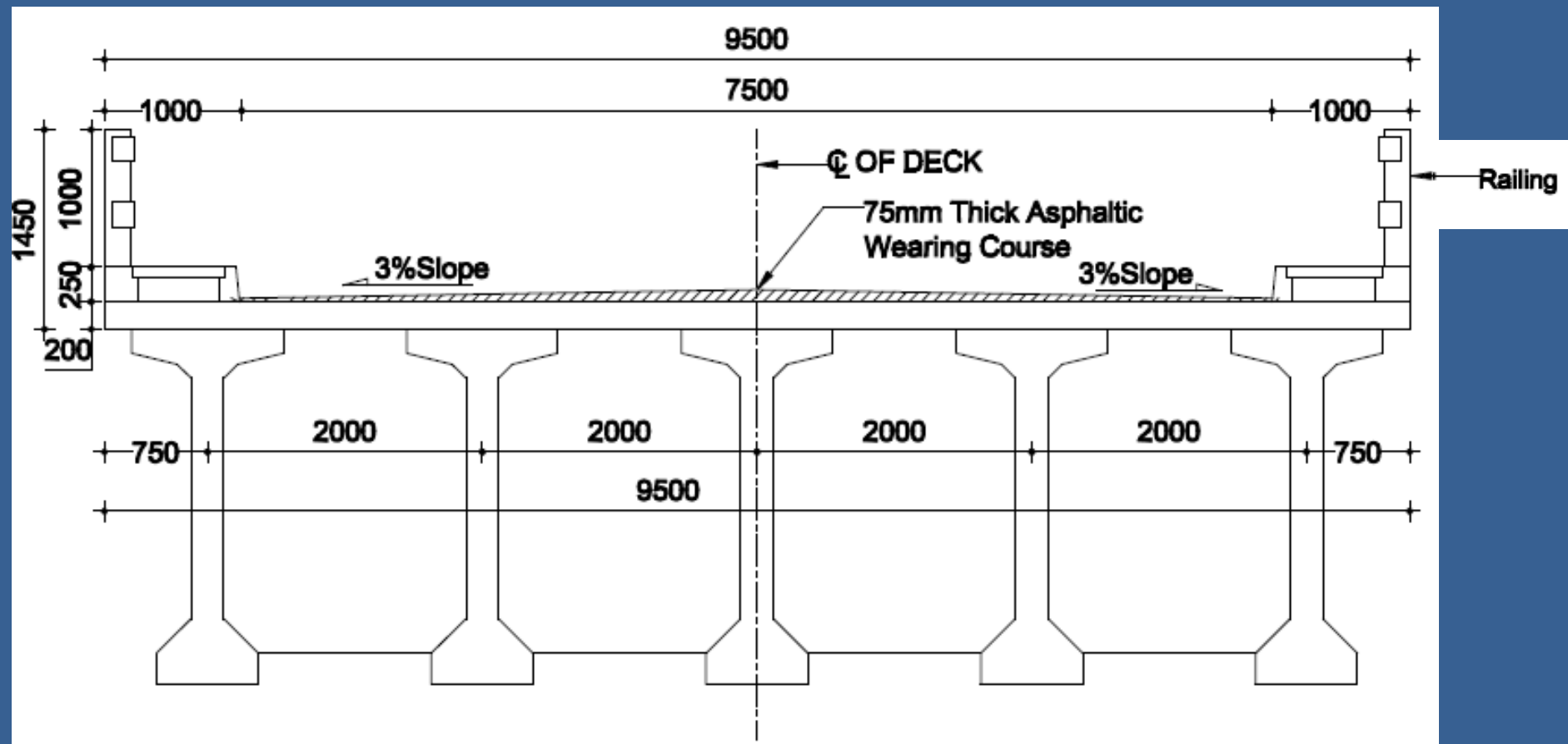

BRIDGE DECK SECTION A-A

- Span (c/c of bearing)= 85ft to 120ft
 - Roll No+84 (Roll No-roll no of 1st student)+85
- Width of bridge (two lane with sidewalk)
 - Odd $\rightarrow 384''$ ($45''+12'-3''+12'-3''+45''$)
 - Even $\rightarrow 368''$ ($40''+12'-0''+12'-0''+40''$)
- No of girder= 4
 - Odd $\rightarrow 36''+3*104''+36''= 384''$
 - Even $\rightarrow 34''+3*100''+34''=368''$

Girder selection

- Span > 95 ft, AASHTO Type VI
- Span < 94 ft, AASHTO Type V
- Bulb-Tee section

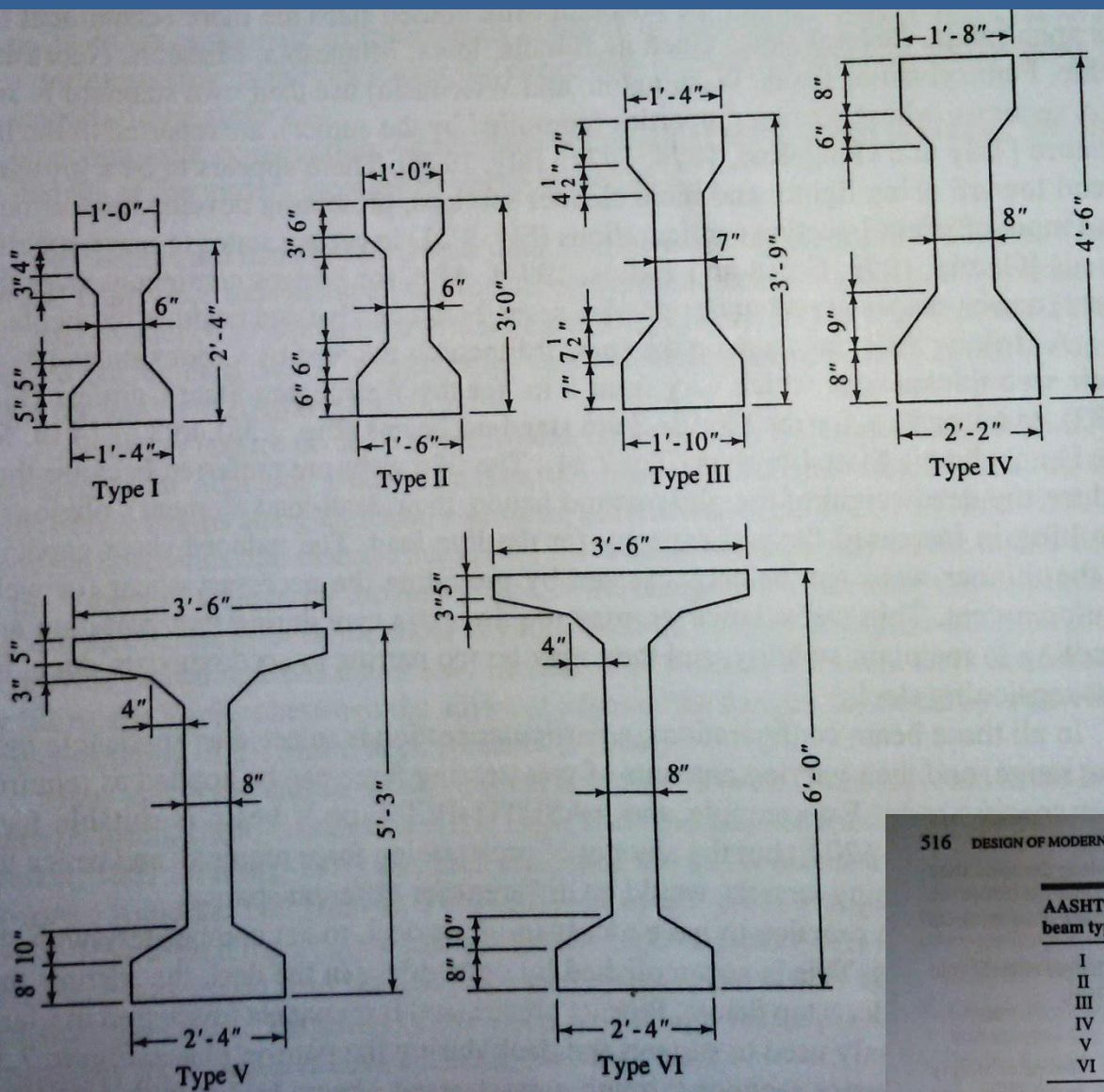

FIGURE 7.30
 Cross sections and section properties of standard AASHTO-PCI I-sections [Lin and Burns, 1981].

AASHTO beam type	Area (in. ²)	I (in. ⁴)	y _b * (in.)	Recommended span limits (ft)
I	276	22,750	12.59	30-45
II	369	50,980	15.83	40-60
III	560	125,390	20.27	55-80
IV	789	260,730	24.73	70-100
V	1013	521,180	31.96	90-120
VI	1085	733,320	36.38	110-140

*From center of gravity to bottom fibers.

- Future wearing-35psf (3", unit wt= 140pcf)
 - Railing
 - Sidewalk
-
- Future wearing -35 psf (A1,B1,C1)
 - Future wearing -40 psf (A2,B2,C2)

Material

Concrete strength

Prestressed girders:	Initial strength at transfer, $f_{ci} = 4.8$ ksi
	28-day strength, $f_c = 6$ ksi
Deck slab:	4.0 ksi
Substructure:	3.0 ksi
Railings:	3.5 ksi

Concrete elastic modulus (calculated using S5.4.2.4)

Girder final elastic modulus, E_c	= 4,696 ksi
Girder elastic modulus at transfer, E_{ci}	= 4,200 ksi
Deck slab elastic modulus, E_s	= 3,834 ksi

Reinforcing steel

Yield strength, $f_y = 60$ ksi

Prestressing strands

0.5 inch diameter low relaxation strands Grade 270

Strand area, A_{ps}	= 0.153 in ²
Steel yield strength, f_{py}	= 243 ksi
Steel ultimate strength, f_{pu}	= 270 ksi
Prestressing steel modulus, E_p	= 28,500 ksi

Beam Properties and Basic Dimensions

<i>Type</i>	<i>Area</i>	<i>Centroid to Btm</i>	<i>Moment of Inertia</i>	<i>Height</i>	<i>Width</i>		
					<i>Top Flange</i>	<i>Web</i>	<i>Bottom Flange</i>
	<i>(in. ²)</i>	<i>(in.)</i>	<i>(in. ⁴)</i>	<i>(in.)</i>	<i>(in.)</i>	<i>(in.)</i>	<i>(in.)</i>
<i>I</i>	276	12.59	22,750	28	12	6	16
<i>II</i>	369	15.83	50,980	36	12	6	18
<i>III</i>	560	20.27	125,390	45	16	7	22
<i>IV</i>	789	24.73	260,730	54	20	8	26
<i>V</i>	1,013	31.96	521,180	63	42	8	28
<i>VI</i>	1,085	36.38	733,320	72	42	8	28

AASHTO I-BEAMS																					
				Depth Data (in.)						Flange Data (in.)				Basic Beam Properties							
Beam Designation	Top Flange Width (in.) W2	Bottom Flange Width (in.) W1	Depth (in.) D	T2	D1	B3	C	B1	T1	X1	B4	B2	Web Thickness (in.) W3	Conc. (CY/ft.)	Area (in. ²)	Yb (in.)	I (in. ⁴)	S _t (in. ³)	S _b (in. ³)	WT/FT. (KIPS)	
28/63	42	28	63	5	3	4	33	10	8	13	4	10	8	0.261	1013	31.96	521162	16788	16308	1.057	
28/66	42	28	66	5	3	4	36	10	8	13	4	10	8	0.267	1037	33.43	587180	18028	17564	1.081	
28/72	42	28	72	5	3	4	42	10	8	13	4	10	8	0.279	1085	36.38	733319	20588	20157	1.130	
28/78	42	28	78	5	3	4	48	10	8	13	4	10	8	0.291	1133	39.34	898984	23251	22854	1.178	
28/84	42	28	84	5	3	4	54	10	8	13	4	10	8	0.304	1181	42.29	1085040	26016	25655	1.231	
28/90	42	28	90	5	3	4	60	10	8	13	4	10	8	0.316	1229	45.26	1292348	28883	28557	1.280	
28/96	42	28	96	5	3	4	66	10	8	13	4	10	8	0.328	1277	48.22	1521775	31850	31559	1.328	

Commonwealth of Pennsylvania

Department of Transportation

Bureau of Design

BD-652M Sheet 2 of 3

I-sections

Agency	Type	D1	D2	D3	D4	D5	D6	B1	B2	B3	B4	A	I	y _b
AASHTO	Type VI	72	5	3	4	10	8	42.9	26.9	6.9	4	1006	699,093	36.4
AASHTO-PCI	BT-72	72	3.5	2	2	4.5	6	42.9	26.9	6.9	2	832	573,909	36.6
Canada	1728 mm	68.0	5.0	2.5	—	3.5	7	25.5	29.9	6.9	—	802	478,762	31.7
	2000 mm	78.7	3.9	3.9	—	5.5	7.1	34.9	29.4	6.9	—	930	758,791	37.6

I-sections with curved surfaces

Agency	Type	D1	D2	D3	D4	D5	B1	B2	B3	R1	R2	R3	R4	A	I	y _b
Florida	BT-72	72	2	4	5.5	7.5	48.4	30.4	6.9	8	8	0	0	930	651,190	34.4
Kentucky*	BT-1800	70.9	3	3.9	6.9	8.9	58.9	27.6	6.9	7.5	7.5	0	7.5	996	696,975	36.5
	NU750	29.5	2.6	1.8	5.5	5.3	49.2	39.4	6.9	7.9	7.9	2.0	2.0	643	71,554	13.6
	NU900	35.4	2.6	1.8	5.5	5.3	49.2	39.4	6.9	7.9	7.9	2.0	2.0	684	114,178	16.2
	NU1100	43.3	2.6	1.8	5.5	5.3	49.2	39.4	6.9	7.9	7.9	2.0	2.0	738	189,390	19.7
Nebraska University	NU1350	53.1	2.6	1.8	5.5	5.3	49.2	39.4	6.9	7.9	7.9	2.0	2.0	806	315,398	24.1
	NU1600	63.0	2.6	1.8	5.5	5.3	49.2	39.4	6.9	7.9	7.9	2.0	2.0	874	480,111	28.6
	NU1800	70.9	2.6	1.8	5.5	5.3	49.2	39.4	6.9	7.9	7.9	2.0	2.0	928	642,003	32.3
	NU2000	78.7	2.6	1.8	5.5	5.3	49.2	39.4	6.9	7.9	7.9	2.0	2.0	982	832,521	36.0
	NU2400	94.5	2.6	1.8	5.5	5.3	49.2	39.4	6.9	7.9	7.9	2.0	2.0	1091	1,306,244	43.4

*Kentucky girder section properties were computed from a straight-line approximation of curved surface.
 Note: Units are in inches and 1 in. = 25.4 mm.

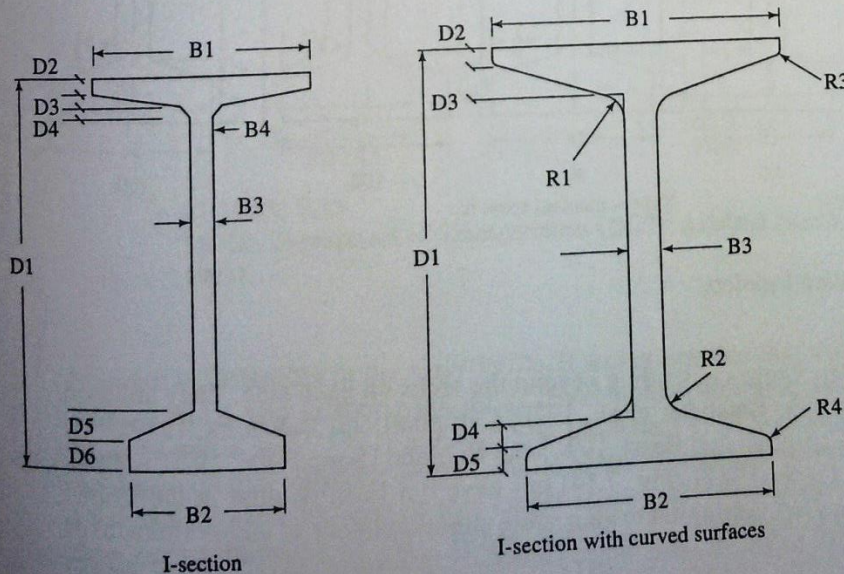
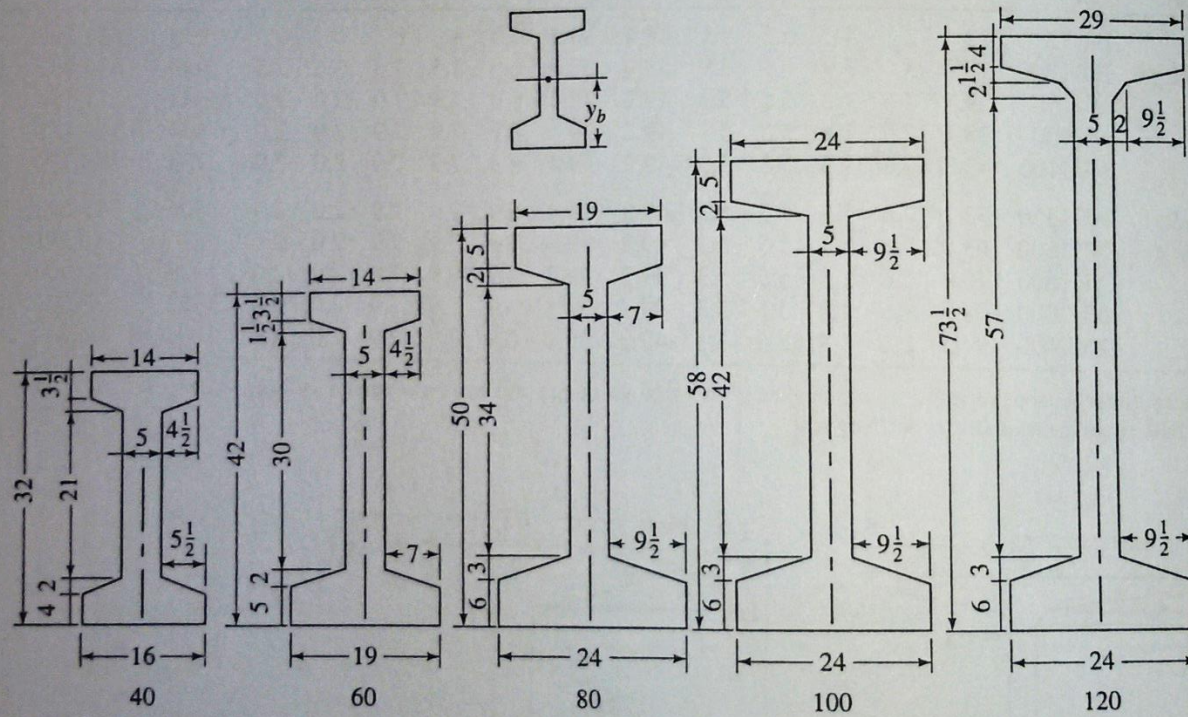

FIGURE 7.31
 New I-girder series developed by Nebraska University for the Nebraska Department of Roads, to be used

Beam properties

Type	Area (in. ²)	y_b (in.)	Moment of inertia (in. ⁴)
40	253	15.16	31,000
60	332	18.63	70,100
80	476	22.53	154,900
100	546	27.90	249,000
120	626	35.60	456,000



(Note: Dimensions in inches)

Type—nominal span, ft

FIGURE 7.32
Washington State standard I-girders.

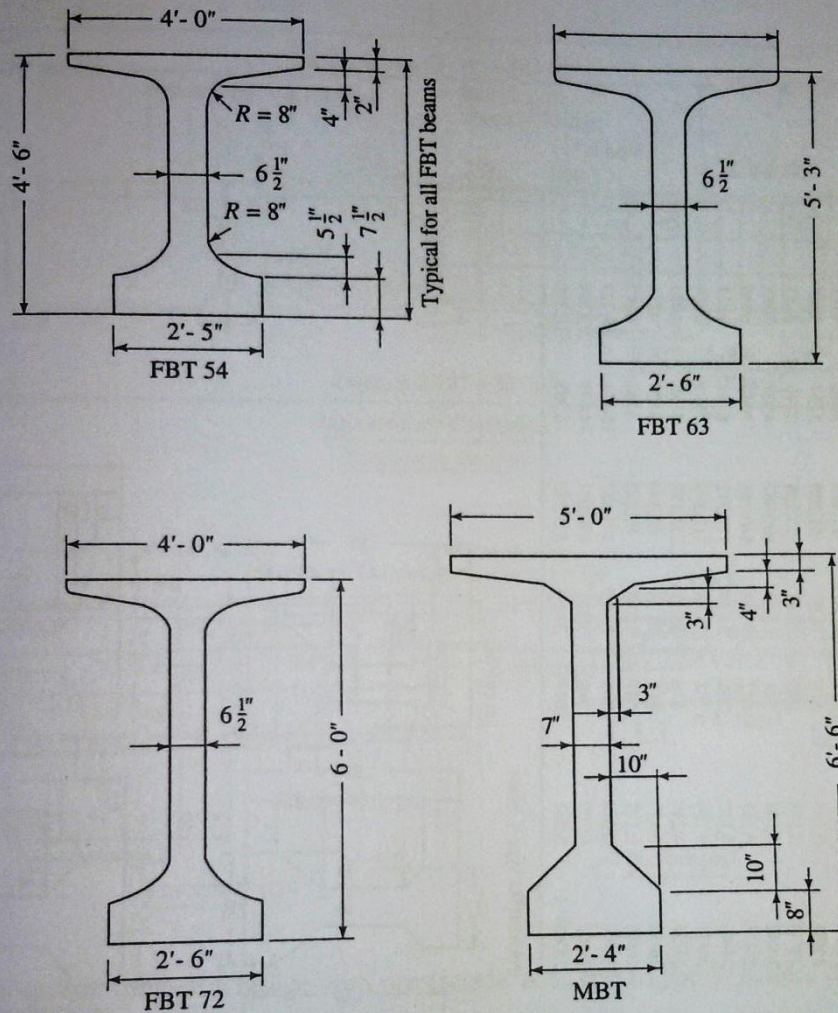
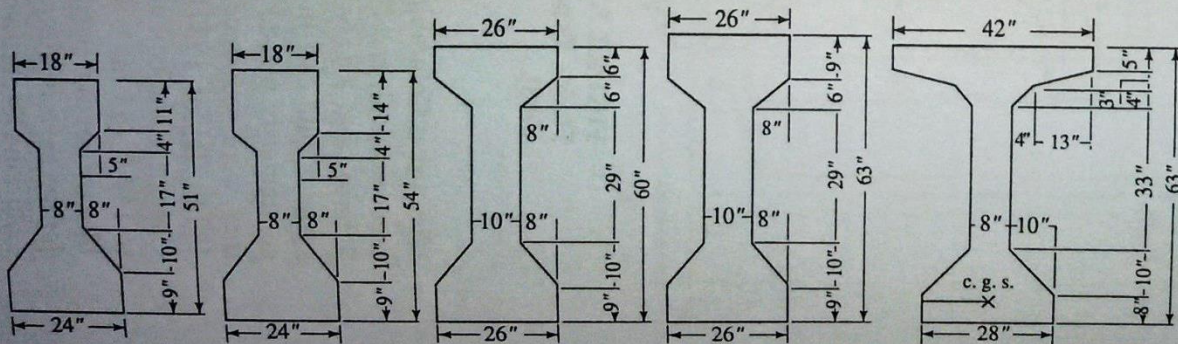
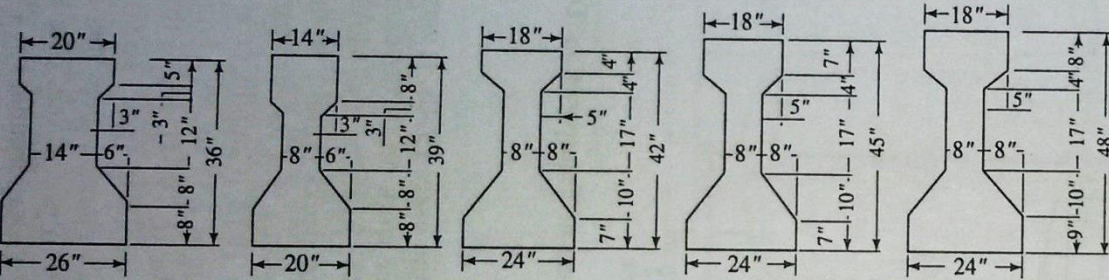
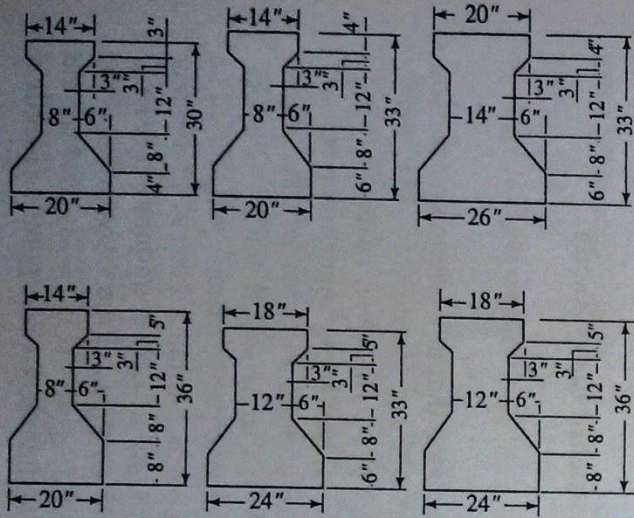

FIGURE 7.33
Florida Department of Transportation (DOT) standard beams [Garcia, 1993].



Beam size	Conc. Cy/Lf (cu. yd./ft)	Section properties				
		A (in. ²)	y _b (in.)	I (in. ⁴)	Z _t (in. ³)	Z _b (in. ³)
20/30	0.093	363	13.12	32,786	1942	2499
20/33	0.107	417	14.35	44,757	2400	3119
20/36	0.121	471	15.62	59,077	2898	3783
20/39	0.132	513	17.41	77,576	3593	4457
24/33	0.141	549	14.87	57,200	3154	3847
24/36	0.158	615	16.17	75,256	3796	4653
24/42	0.151	588	18.04	107,967	4504	5985
24/45	0.165	642	20.18	140,065	5644	6940
24/48	0.182	708	21.39	172,712	6490	8075
24/51	0.196	762	23.38	212,399	7691	9084
24/54	0.210	816	25.31	255,194	8895	10,083
26/33	0.158	615	15.04	63,346	3528	4211
26/36	0.177	687	16.37	83,247	4240	5087
26/60	0.249	968	28.52	391,487	12,434	13,729
26/63	0.269	1046	30.97	470,081	14,678	15,176
28/63*	0.261	1013	31.96	521,163	16,788	16,308

*AASHTO Type V beam

FIGURE 7.34
Standard I-beams used by the Pennsylvania Department of Transportation [PennDOT, 1993b].

2.1 Bridge geometry and materials

Bridge superstructure geometry

Superstructure type:	Reinforced concrete deck supported on simple span prestressed girders made continuous for live load.
Spans:	Two spans at 110 ft. each
Width:	55'-4 ½" total 52'-0" gutter line-to-gutter line (Three lanes 12'- 0" wide each, 10 ft. right shoulder and 6 ft. left shoulder. For superstructure design, the location of the driving lanes can be anywhere on the structure. For substructure design, the maximum number of 12 ft. wide lanes, i.e., 4 lanes, is considered)
Railings:	Concrete Type F-Parapets, 1'- 8 ¼" wide at the base
Skew:	20 degrees, valid at each support location
Girder spacing:	9'-8"
Girder type:	AASHTO Type VI Girders, 72 in. deep, 42 in. wide top flange and 28 in. wide bottom flange (AASHTO 28/72 Girders)
Strand arrangement:	Straight strands with some strands debonded near the ends of the girders
Overhang:	3'-6 ¼" from the centerline of the fascia girder to the end of the overhang
Intermediate diaphragms:	For load calculations, one intermediate diaphragm, 10 in. thick, 50 in. deep, is assumed at the middle of each span.

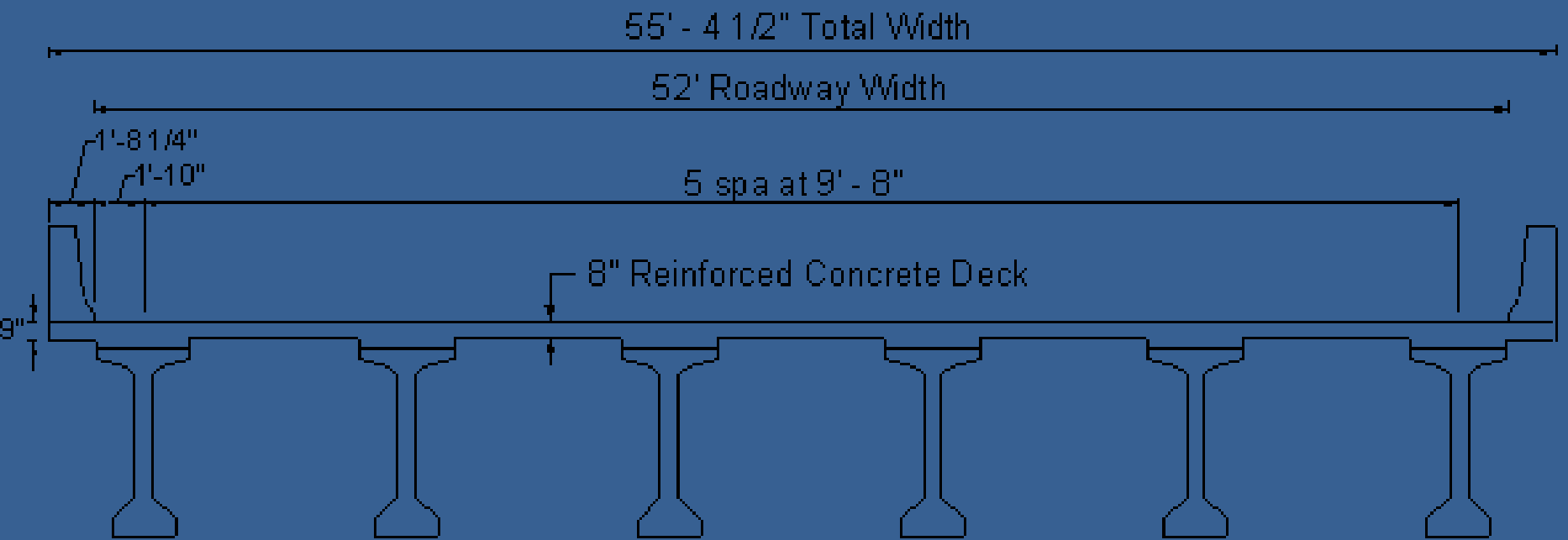

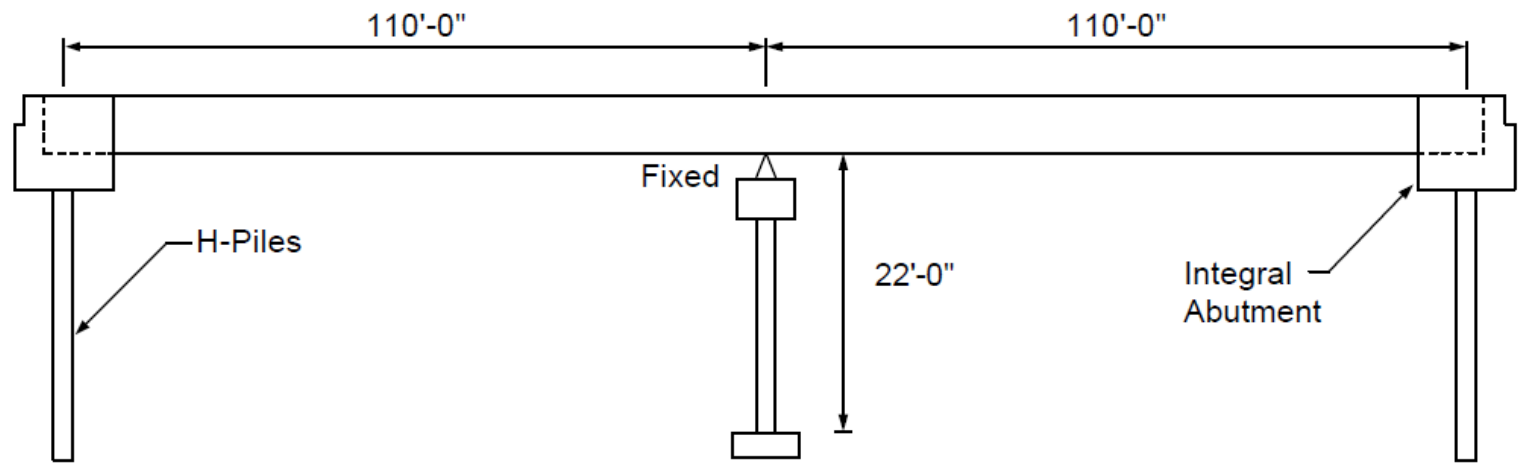
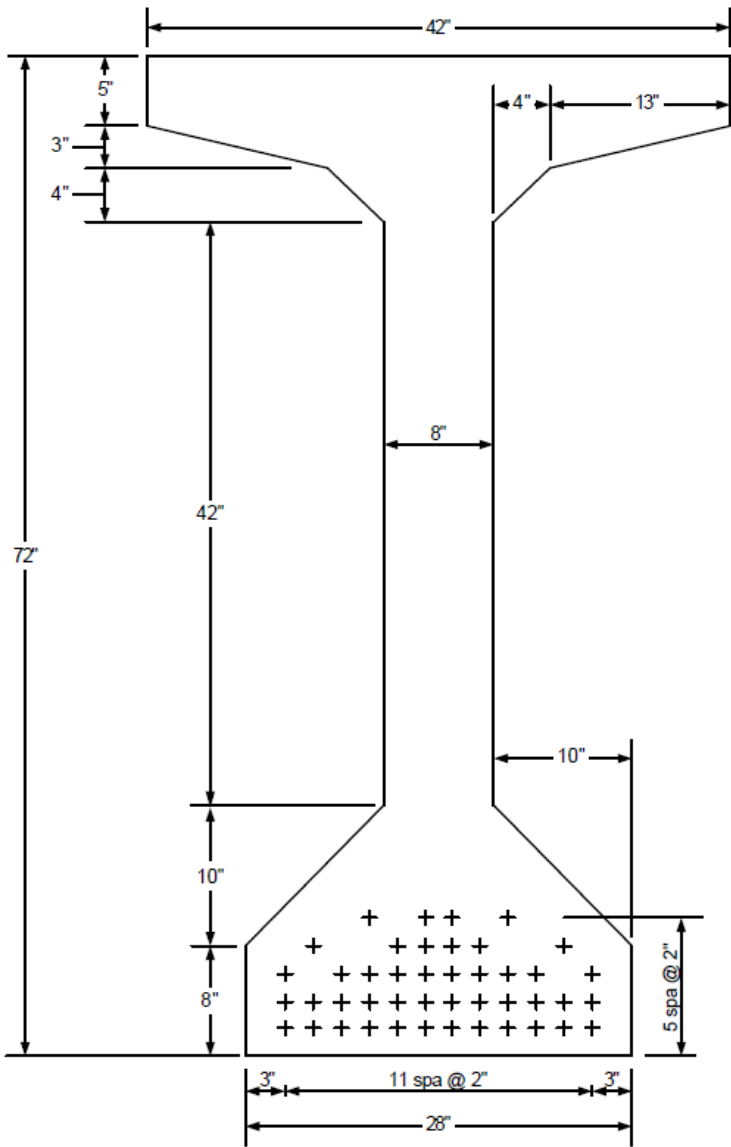

Figure 2-1 – Elevation View of the Example Bridge



Effective Slab width

- Interior-smaller of
 - $\text{Span}/4$
 - Greater of
 - $12 \text{ avg slab thickness} + \text{web thickness}$
 - $12 \text{ avg slab thickness} + 1/2 \text{ width of top flange}$
 - Centre to centre

For interior girders :

The effective flange width is taken as the least of the following:

- One-quarter of the effective span length $= 0.25(82.5)(12)$
 $= 247.5$ in.
- 12.0 times the average thickness of the slab,
plus the greater of the web thickness $= 12(7.5) + 8 = 104$ in.
or
one-half the width of the top flange of the girder $= 12(7.5) + 0.5(42)$
 $= \underline{111}$ in.
- The average spacing of adjacent beams $= 9$ ft.- 8 in. or 116 in.

The effective flange width for the interior beam is 111 in.

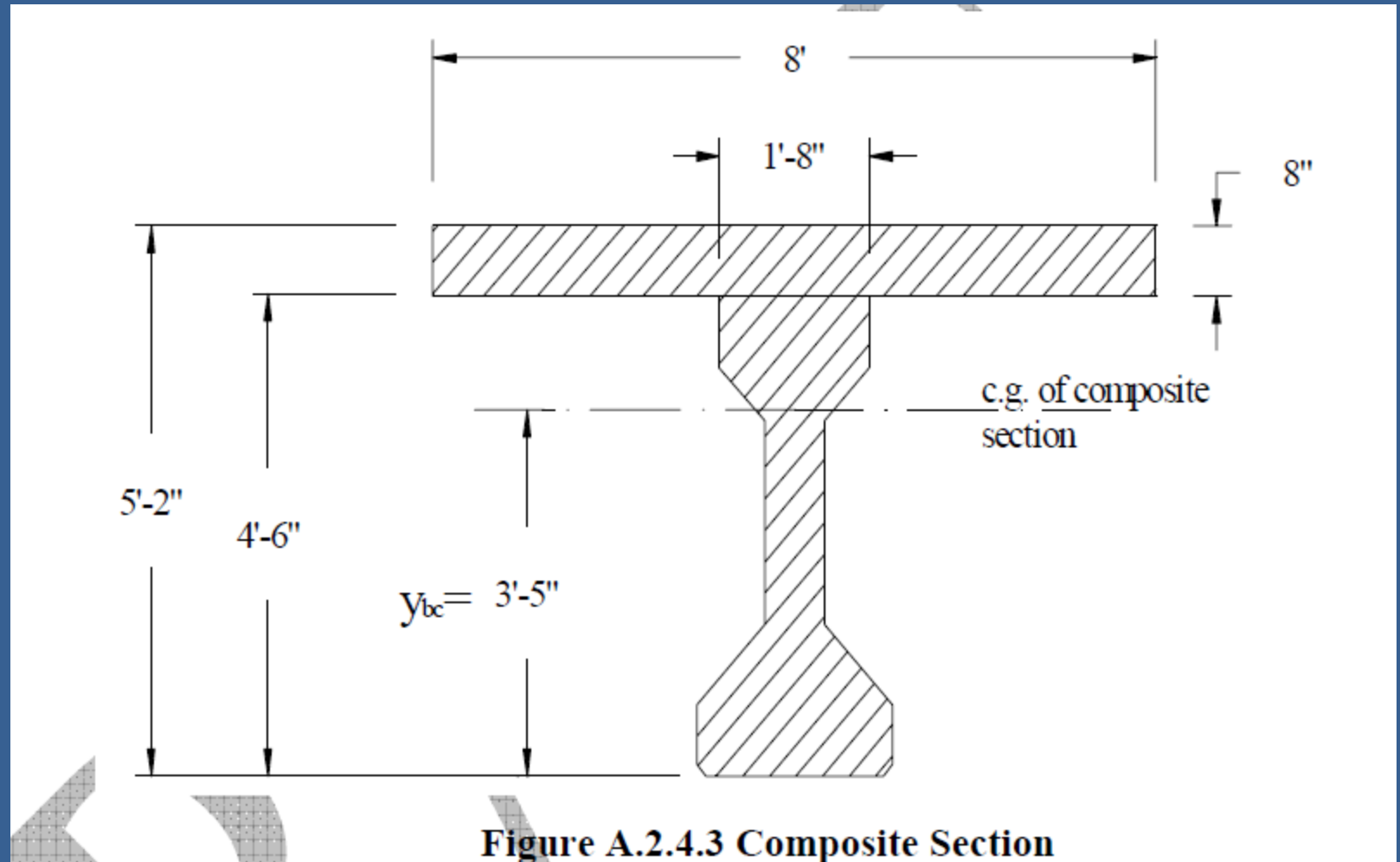

- From another problem

Slab Design

Slab/Deck thickness

- Not less than 7 in
- If less than $\text{span}/20$, prestressing required
- Generally not less than 8in (including 0.5in integral wearing)

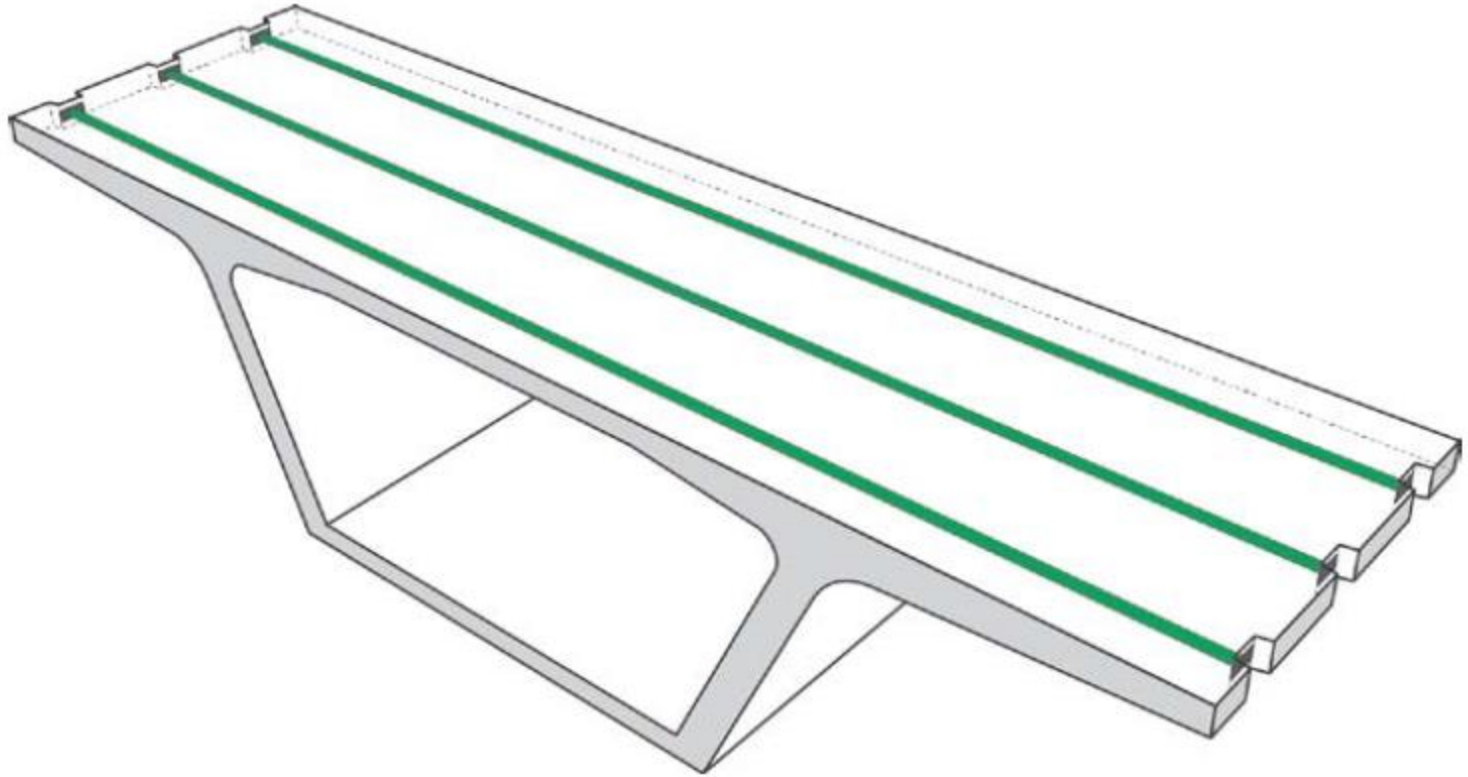

Figure 1.24 - Transverse Post-Tensioning in the Top Slab of Box Girder

Dead Load Moment

- $M = \frac{wl^2}{10}$ or $\frac{wl^2}{12}$
- Self weight = $\frac{8}{12} * 150 = 100$ psf
- Future wearing = 30 psf
- Span of one way slab = c/c of girder
- +ve -ve Moment $M_{DL} = \frac{0.1 * 9.66^2}{10} = 0.933$ k-ft/ft
- +ve -ve Moment $M_{wear} = \frac{0.03 * 9.66^2}{10} = 0.28$ k-ft/ft

Design section for negative moment

- $\frac{1}{3} * \text{top flange} = \frac{1}{3} * 42 = 14 \text{ in.} < 15 \text{ in.}$ Ok

Live Load Effects

APPENDIX A4—DECK SLAB DESIGN TABLE

Table A4-1 may be used in determining the design moments for different girder arrangements. The following assumptions and limitations were used in developing this table and should be considered when using the listed values for design:

- The moments are calculated using the equivalent strip method as applied to concrete slabs supported on parallel girders.
- Multiple presence factors and the dynamic load allowance are included in the tabulated values.
- See Article 4.6.2.1.6 for the distance between the center of the girders to the location of the design sections for negative moments in the deck. Interpolation between the listed values may be used for distances other than those listed in Table A4-1.
- The moments are applicable for decks supported on at least three girders and having a width of not less than 14.0 ft between the centerlines of the exterior girders.
- The moments represent the upper bound for the moments in the interior regions of the slab and, for any specific girder spacing, were taken as the maximum value calculated, assuming different number of girders in the bridge cross-section. For each combination of girder spacing and number of girders, the following two cases of overhang width were considered:
 - (a) Minimum total overhang width of 21.0 in. measured from the center of the exterior girder, and
 - (b) Maximum total overhang width equal to the smaller of 0.625 times the girder spacing and 6.0 ft.

A railing system width of 21.0 in. was used to determine the clear overhang width. For other widths of railing systems, the difference in the moments in the interior regions of the deck is expected to be within the acceptable limits for practical design.

- The moments do not apply to the deck overhangs and the adjacent regions of the deck that need to be designed taking into account the provisions of Article A13.4.1.
- It was found that the effect of two 25^k axles of the tandem, placed at 4.0 ft from each other, produced maximum effects under each of the tires approximately equal to the effect of the 32^k truck axle. The tandem produces a larger total moment, but this moment is spread over a larger width. It was concluded that repeating calculations with a different strip width for the tandem would not result in a significant difference.

Table A4-1—Maximum Live Load Moments per Unit Width, kip-ft/ft

<i>S</i>	Positive Moment	Negative Moment							
		Distance from CL of Girder to Design Section for Negative Moment							
		0.0 in.	3 in.	6 in.	9 in.	12 in.	18 in.	24 in.	
4'	-0"	4.68	2.68	2.07	1.74	1.60	1.50	1.34	1.25
4'	-3"	4.66	2.73	2.25	1.95	1.74	1.57	1.33	1.20
4'	-6"	4.63	3.00	2.58	2.19	1.90	1.65	1.32	1.18
4'	-9"	4.64	3.38	2.90	2.43	2.07	1.74	1.29	1.20
5'	-0"	4.65	3.74	3.20	2.66	2.24	1.83	1.26	1.12
5'	-3"	4.67	4.06	3.47	2.89	2.41	1.95	1.28	0.98
5'	-6"	4.71	4.36	3.73	3.11	2.58	2.07	1.30	0.99
5'	-9"	4.77	4.63	3.97	3.31	2.73	2.19	1.32	1.02
6'	-0"	4.83	4.88	4.19	3.50	2.88	2.31	1.39	1.07
6'	-3"	4.91	5.10	4.39	3.68	3.02	2.42	1.45	1.13
6'	-6"	5.00	5.31	4.57	3.84	3.15	2.53	1.50	1.20
6'	-9"	5.10	5.50	4.74	3.99	3.27	2.64	1.58	1.28
7'	-0"	5.21	5.98	5.17	4.36	3.56	2.84	1.63	1.37
7'	-3"	5.32	6.13	5.31	4.49	3.68	2.96	1.65	1.51
7'	-6"	5.44	6.26	5.43	4.61	3.78	3.15	1.88	1.72
7'	-9"	5.56	6.38	5.54	4.71	3.88	3.30	2.21	1.94
8'	-0"	5.69	6.48	5.65	4.81	3.98	3.43	2.49	2.16
8'	-3"	5.83	6.58	5.74	4.90	4.06	3.53	2.74	2.37
8'	-6"	5.99	6.66	5.82	4.98	4.14	3.61	2.96	2.58
8'	-9"	6.14	6.74	5.90	5.06	4.22	3.67	3.15	2.79
9'	-0"	6.29	6.81	5.97	5.13	4.28	3.71	3.31	3.00

Table A4-1—Maximum Live Load Moments per Unit Width, kip-ft/ft

S	Positive Moment	Negative Moment							
		Distance from CL of Girder to Design Section for Negative Moment							
		0.0 in.	3 in.	6 in.	9 in.	12 in.	18 in.	24 in.	
9'	-0"	6.29	6.81	5.97	5.13	4.28	3.71	3.31	3.00
9'	-3"	6.44	6.87	6.03	5.19	4.40	3.82	3.47	3.20
9'	-6"	6.59	7.15	6.31	5.46	4.66	4.04	3.68	3.39
9'	-9"	6.74	7.51	6.65	5.80	4.94	4.21	3.89	3.58
10'	-0"	6.89	7.85	6.99	6.13	5.26	4.41	4.09	3.77
10'	-3"	7.03	8.19	7.32	6.45	5.58	4.71	4.29	3.96
10'	-6"	7.17	8.52	7.64	6.77	5.89	5.02	4.48	4.15
10'	-9"	7.32	8.83	7.95	7.08	6.20	5.32	4.68	4.34
11'	-0"	7.46	9.14	8.26	7.38	6.50	5.62	4.86	4.52
11'	-3"	7.60	9.44	8.55	7.67	6.79	5.91	5.04	4.70
11'	-6"	7.74	9.72	8.84	7.96	7.07	6.19	5.22	4.87
11'	-9"	7.88	10.01	9.12	8.24	7.36	6.47	5.40	5.05
12'	-0"	8.01	10.28	9.40	8.51	7.63	6.74	5.56	5.21
12'	-3"	8.15	10.55	9.67	8.78	7.90	7.02	5.75	5.38
12'	-6"	8.28	10.81	9.93	9.04	8.16	7.28	5.97	5.54
12'	-9"	8.41	11.06	10.18	9.30	8.42	7.54	6.18	5.70
13'	-0"	8.54	11.31	10.43	9.55	8.67	7.79	6.38	5.86
13'	-3"	8.66	11.55	10.67	9.80	8.92	8.04	6.59	6.01
13'	-6"	8.78	11.79	10.91	10.03	9.16	8.28	6.79	6.16
13'	-9"	8.90	12.02	11.14	10.27	9.40	8.52	6.99	6.30
14'	-0"	9.02	12.24	11.37	10.50	9.63	8.76	7.18	6.45
14'	-3"	9.14	12.46	11.59	10.72	9.85	8.99	7.38	6.58
14'	-6"	9.25	12.67	11.81	10.94	10.08	9.21	7.57	6.72
14'	-9"	9.36	12.88	12.02	11.16	10.30	9.44	7.76	6.86
15'	-0"	9.47	13.09	12.23	11.37	10.51	9.65	7.94	7.02

Strength I

- Strength I = 1.25 Self +1.5 Wear +1.75 LL
- Positive $M_{DL} = 1.25 * 0.933 + 1.5 * 0.28 + 1.75 * 6.74$
= 13.38 k-ft/ft

$$\begin{aligned}d &= \text{total thickness} - \text{cover} - 0.5 \text{ bar dia} - \text{wearing} \\ &= 8.0 - 1.0 - 0.5 * 0.625 - 0.5 \\ &= 6.19 \text{ in}\end{aligned}$$

Design for positive moment

- $k' = \frac{M_u}{\phi b d^2} = 0.388 \text{ k/in}^2$

- $\rho = 0.85 \frac{f_c'}{f_y} \left[1.0 - \sqrt{1 - \frac{2k'}{0.85f_c'}} \right]$
 $= 0.00688$

- Use ACI formula

$$A_s = 0.0426 \text{ in}^2/\text{in}$$

#5 @ 7 in c/c

bottom steel perpendicular to traffic

Maximum minimum reinforcement

- Check c/d_t or steel strain

5.7.3.3.2 Minimum Reinforcement

Unless otherwise specified, at any section of a noncompression-controlled flexural component, the amount of prestressed and nonprestressed tensile reinforcement shall be adequate to develop a factored flexural resistance, M_r , at least equal to the lesser of:

- 1.33 times the factored moment required by the applicable strength load combination specified in Table 3.4.1-1; and

- $$M_{cr} = \gamma_3 \left[(\gamma_1 f_r + \gamma_2 f_{cpe}) S_c - M_{dnc} \left(\frac{S_c}{S_{nc}} - 1 \right) \right]$$

(5.7.3.3.2-1)

where:

f_r = modulus of rupture of concrete specified in Article 5.4.2.6

f_{cpe} = compressive stress in concrete due to effective prestress forces only (after allowance for all prestress losses) at extreme fiber of section where tensile stress is caused by externally applied loads (ksi)

M_{dnc} = total unfactored dead load moment acting on the monolithic or noncomposite section (kip-in.)

S_c = section modulus for the extreme fiber of the composite section where tensile stress is caused by externally applied loads (in.³)

S_{nc} = section modulus for the extreme fiber of the monolithic or noncomposite section where tensile stress is caused by externally applied loads (in.³)

Crack width control at Service I

- Allowable reinforcement Stress

Check for cracking under Service I Limit State (S5.7.3.4)

Allowable reinforcement service load stress for crack control using Eq. S5.7.3.4-1:

$$f_{sa} = \frac{Z}{(d_c A)^{1/3}} \leq 0.6f_y = 36 \text{ ksi}$$

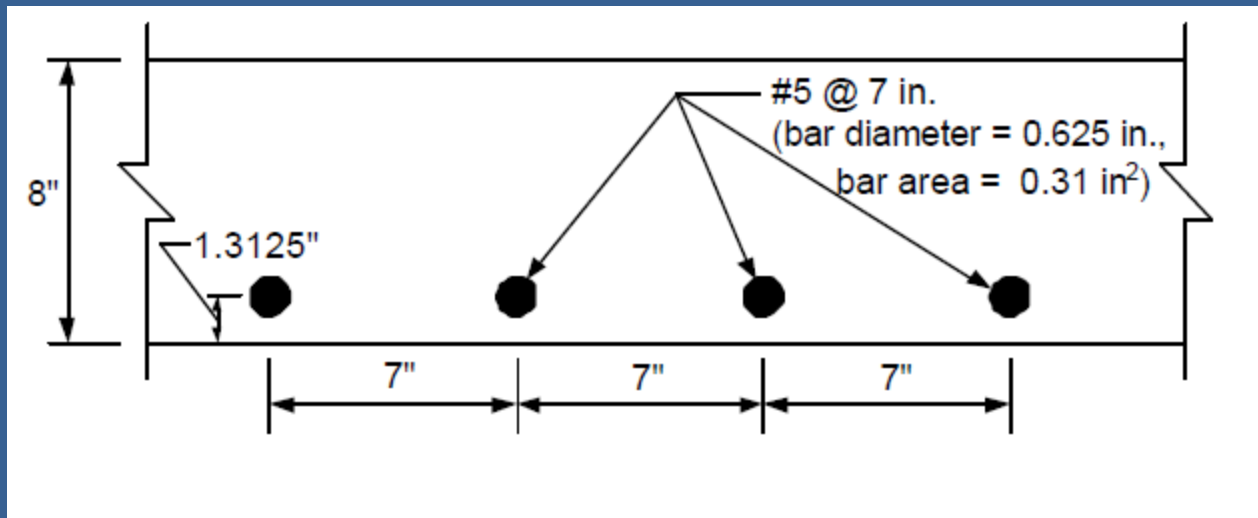

Control of Cracking by distribution of Reinforcement

Control of Cracking by Distribution of Reinforcement (Sec. 5.7.3.4 AASHTO 2012)

The spacing s of mild steel reinforcement in the layer closest to the tension face shall satisfy the following:

$$s \leq \frac{700\gamma_e}{\beta_s f_{ss}} - 2d_c$$

$$\beta_s = 1 + \frac{d_c}{0.7(h - d_c)}$$

Actual spacing of steel shall not be more than s calculated above.

- γ_e = exposure factor
 - = 1.00 for Class 1 exposure condition
 - = 0.75 for Class 2 exposure condition
- d_c = thickness of concrete cover measured from extreme tension fiber to center of the flexural reinforcement located closest thereto (in.)
- f_{ss} = tensile stress in steel reinforcement at the service limit state (ksi)
- h = overall thickness or depth of the component (in.)
- d_t = distance from the extreme compression fiber to the centroid of extreme tension steel element (in.)

$$\text{Assume } f_{ss} = f_y \times (M_{\text{SERVICE}}/M_{\text{STRENGTH}})$$

where:

d_c = thickness of concrete cover measured from extreme tension fiber to center of bar located closest thereto (in.)

$$= 1.3125 \text{ in.} < (2 + \frac{1}{2} \text{ bar diameter}) \text{ in.} \quad \mathbf{OK}$$

A = area of concrete having the same centroid as the principal tensile reinforcement and bounded by the surfaces of the cross-section and a straight line parallel to the neutral axis, divided by the number of bars (in²)

$$= 2(1.3125)(7)$$

$$= 18.375 \text{ in}^2$$

Positive Moment

$$M_{\text{strength I}} = 13.38 \text{ kip-ft/ft}$$

$$M_{\text{service I}} = 0.933 + 0.28 + 6.74$$
$$= 7.953 \text{ kip-ft/ft}$$

$$f_{ss} = f_y + \frac{7.953}{13.38}$$
$$= 35.66 \text{ ksi}$$

$$d_c = 1 + 0.3125 < \left(2'' + \frac{d_{\text{bar}}}{2}\right)$$
$$= 1.3125$$

$$A = 2 + 1.3125 + 7$$
$$= 18.375 \text{ in}^2$$

$$\beta_s = 1 + \frac{d_c}{0.7(h-d_c)} = 1 + \frac{1.3125}{0.7(8-1.3125)} = \frac{1.80}{1.28}$$

$$s \leq \frac{700d_c}{\beta_s f_{ss}} - 2d_c = \frac{700 \times 1}{1.28 \times 35.66} - 2 + 1.3125$$
$$= 12.47''$$

#5 @ 7" c/c is OK.

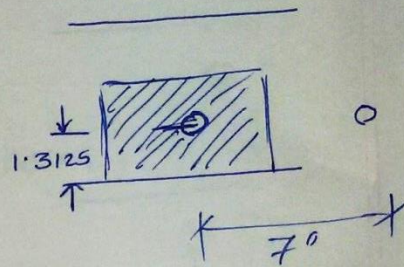

Design for negative moment

- Strength I = 1.25 Self +1.5 Wear +1.75 LL
- Negative

$$M_{DL} = 1.25 * 0.933 + 1.5 * 0.28 + 1.75 * 4.21$$
$$= 8.95 \text{ k-ft/ft}$$

d = total thickness – top cover – 0.5 bar dia

$$= 8.0 - 2.5 - 0.5 * 0.625$$

$$= 5.19 \text{ in}$$

Design for negative moment

- $k' = \frac{M_u}{\phi b d^2} = \quad \text{k/in}^2$

- $\rho = 0.85 \frac{f_c'}{f_y} \left[1.0 - \sqrt{1 - \frac{2k'}{0.85f_c'}} \right]$
=

$$A_s = 0.0339 \text{ in}^2/\text{in}$$

#5 @ 9 in c/c

Top steel perpendicular to traffic

Crack control top surface

Negative Moment

$$M_{STR I} = 8.95 \text{ k-ft/ft}$$

$$M_{serv} = 0.933 + 0.28 + 4.21 = 5.423 \text{ k-ft/ft}$$

$$f_{ss} = 60 \times \frac{5.423}{8.95} = 36.3 \text{ ksi}$$

$$d_c = 2 + 3125$$

$$= 2.3125''$$

2" cover is max^m is d_c calculation

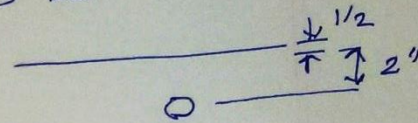

$$\beta_s = 1 + \frac{d_c}{0.7(h-d_c)} = 1 + \frac{2.3125}{\frac{0.7(8-2.3125)}{7.5}} = 1.64$$

$$s \leq \frac{7008e}{\beta_s f_{ss}} - 2d_c = \frac{7008e}{1.64 \times 36.3} - 2 \times 2.3125$$

$$= 7.13''$$

#5 @ 9" e/c spacing is reduced to #5 @ 7" c/c

Longitudinal Reinforcement

- $\frac{220}{\sqrt{S}} \leq 67\%$
- S = the effective span length taken as equal to the effective length specified in S9.7.2.3 (ft.); the distance between sections for negative moment and sections at the ends of one deck span
 - = $(116 - 14 - 14)/(12)$
 - = 7.33 ft.

Longitudinal Reinforcement (Bottom)

$$\text{Percentage} = \frac{220}{\sqrt{7.33}} = 81\% > 67\%$$

Use 67% of transverse reinforcement

Transverse reinforcement = #5 at 7 in. spacing = $0.53 \text{ in}^2/\text{ft}$

Required longitudinal reinforcement = $0.67(0.53) = 0.36 \text{ in}^2/\text{ft}$

Use #5 bars; bar diameter = 0.625 in., bar area = 0.31 in^2

Required spacing = $0.31/0.36 = 0.86 \text{ ft. (10.375 in.)}$

Use #5 bars at 10 in. spacing

bottom steel parallel to traffic

Longitudinal Reinforcement (Top)

- There are no specific requirements to determine this reinforcement. Many jurisdictions use #4 bars at 12 in. spacing for the top longitudinal reinforcement
- Check Shrinkage and Temperature reinforcement

Shrinkage and Temperature Reinforcement

Shrinkage and Temperature Reinforcement (AASHTO 2012 Sec 5.10.8)

Reinforcement for shrinkage and temperature stresses shall be provided near surfaces of concrete exposed to daily temperature changes and in structural mass concrete. Temperature and shrinkage reinforcement to ensure that the total reinforcement on exposed surfaces is not less than that specified herein.

For bars or welded wire fabric, the area of reinforcement per foot, on each face and in each direction, shall satisfy:

$$A_s \geq \frac{1.30bh}{2(b+h)f_y} \quad (5.10.8-1)$$

$$0.11 \leq A_s \leq 0.60 \quad (5.10.8-2)$$

A_s = area of reinforcement in each direction and each face (in.²/ft)

b = least width of component section (in.)

h = least thickness of component section (in.)

f_y = specified yield strength of reinforcing bars
≤ 75 ksi

Shrinkage and Temperature Reinforcement

Shrinkage and Temperature Reinforcement (AASHTO 2012 Sec 5.10.8)

Where the least dimension varies along the length of wall, footing, or other component, multiple sections should be examined to represent the average condition at each section.

Spacing shall not exceed:

- 3.0 times the component thickness, or 18.0 in.**
- 12.0 in. for walls and footings greater than 18.0 in. thick**
- 12.0 in. for other components greater than 36.0 in. thick**

For components 6.0 in. or less in thickness the minimum steel specified may be placed in a single layer. Shrinkage and temperature steel shall not be required for:

- End face of walls 18 in. or less in thickness.**
- Side faces of buried footings 36 in. or less in thickness**
- Faces of all other components, with smaller dimension less than or equal to 18.0 in.**

Shrinkage and Temperature steel

Shrinkage and Temperature

$$A_s \geq \frac{1.30bh}{2(b+h)f_y}, \text{ in}^2/\text{ft} \quad 0.11 \leq A_s \leq 0.60$$
$$= \frac{1.3 * \text{Area}}{\text{Perimeter} * f_y}$$

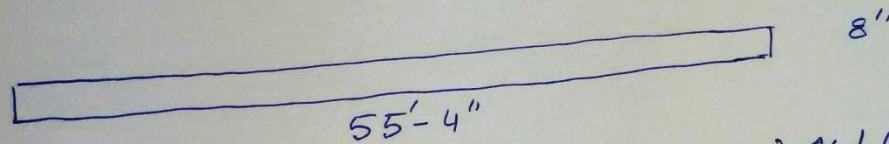

$$= \frac{1.3 * 664 * 8}{1344 + 60} = 0.0856 \text{ in}^2/\text{ft.}$$

area per ft each face
each direction

$$\text{Min}^m = 0.11 \text{ in}^2/\text{ft.}$$

Provided \Rightarrow # 4 @ 12" c/c ~~is not~~ common
 $= 0.20 \text{ in}^2/\text{ft}$ (ok)

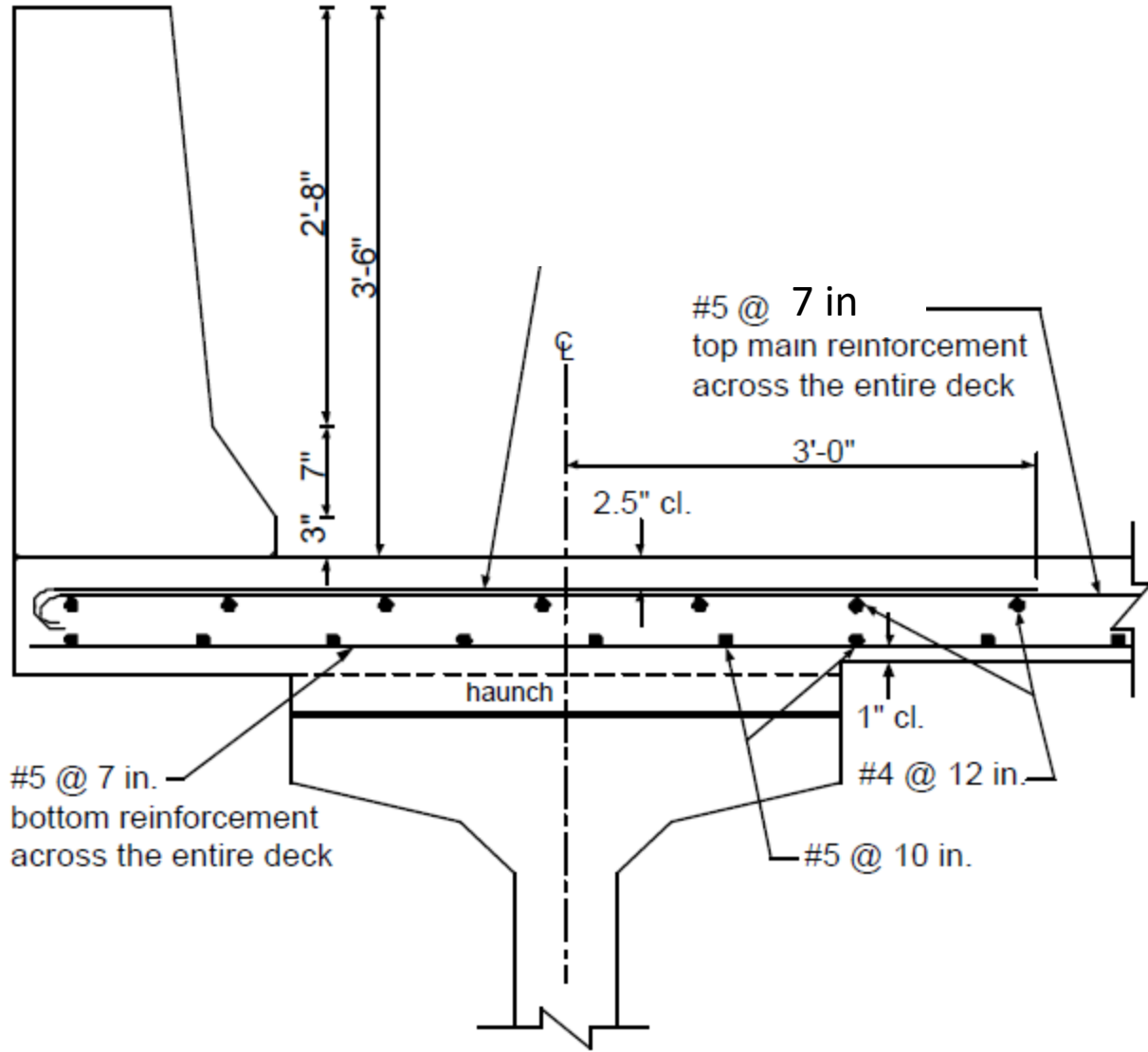

Slab design summary

- Select thickness- min 7", Let 8" ($7.5+0.5$ integral wearing surface)
 - Clear cover top 2", bottom 1"
- Find Moments for DL LL , positive, negative
- Find flexural steel for Strength I, main steel size min #5
- Check crack control for Service I, may reduce spacing
- Find distribution steel along traffic, this is bottom steel
- Find Shrinkage and Temperature steel, this will be top steel along traffic, other steels are already found and more than this. However, #4 @ 12" is common.
- There will four curtains of steel- two top, two bottom

Before next class

- Complete slab design
- Draw effective composite section
- Find section properties (A , c_g , I)
 - Girder only
 - Composite section

GIRDER DESIGN

Super Imposed Dead Load

Dead loads placed on the composite structure:

The permanent loads on the bridge including loads from railing and wearing surface can be distributed uniformly among all beams if the following conditions are met:

[LRFD Art. 4.6.2.2.1]

- Width of deck is constant;
 - Unless otherwise specified, the number of beams is not less than four;
-
- Beams are parallel and have approximately the same stiffness;
 - Unless otherwise specified, the roadway part of the overhang, d_e , does not exceed 3.0 ft;
 - Curvature in plan is less than the limit specified in Article 4.6.1.2.4, or where distribution factors are required in order to implement an acceptable approximate or refined analysis method satisfying the requirements of Article 4.4 for bridges of any degree of curvature in plan; and
 - Cross-section is consistent with one of the cross-sections shown in Table 4.6.2.2.1-1.

DEAD LOAD CALCULATION

Calculate the dead load of the bridge superstructure components for the controlling interior girder. Values for the exterior girder have also been included for reference. The girder, slab, haunch, and exterior diaphragm loads are applied to the noncomposite section; the parapets and future wearing surface are applied to the composite section.

Interior girder

Girder weight

$$DC_{\text{girder (I)}} = A_g(\gamma_{\text{girder}})$$

where:

$$\begin{aligned} A_g &= \text{beam cross-sectional area (in}^2\text{)} \\ &= 1,085 \text{ in}^2 \end{aligned}$$

$$\begin{aligned} \gamma &= \text{unit weight of beam concrete (kcf)} \\ &= 0.150 \text{ kcf} \end{aligned}$$

$$\begin{aligned} DC_{\text{girder (I)}} &= (1,085/144)(0.150) \\ &= 1.13 \text{ k/ft/girder} \end{aligned}$$

Deck slab weight

The total thickness of the slab is used in calculating the weight.

Girder spacing = 9.667 ft.

Slab thickness = 8 in.

$$\begin{aligned} DC_{\text{slab (I)}} &= 9.667(8/12)(0.150) \\ &= 0.967 \text{ k/ft/girder} \end{aligned}$$

- Wearing= 30psf

Exterior girder

Girder weight

$$DC_{\text{girder (E)}} = 1.13 \text{ k/ft/girder}$$

Deck slab weight

$$\begin{aligned} \text{Slab width} &= \text{overhang width} + \frac{1}{2} \text{ girder spacing} \\ &= 3.521 + \frac{1}{2}(9.667) \\ &= 8.35 \text{ ft.} \end{aligned}$$

$$\text{Slab thickness} = 8 \text{ in.}$$

$$\begin{aligned}DC_{\text{slab (E)}} &= 8.35(8/12)(0.150) \\ &= 0.835 \text{ k/ft/girder}\end{aligned}$$

Haunch weight

$$\text{Width} = 42 \text{ in.}$$

$$\text{Thickness} = 4 \text{ in.}$$

$$\begin{aligned}DC_{\text{haunch}} &= [42(4)/144](0.150) \\ &= 0.175 \text{ k/ft/girder}\end{aligned}$$

Concrete diaphragm weight

A concrete diaphragm is placed at one-half the noncomposite span length.

Location of the diaphragms:

Span 1 = 54.5 ft. from centerline of end bearing

Span 2 = 55.5 ft. from centerline of pier

For this example, arbitrarily assume that the thickness of the diaphragm is 10 in. The diaphragm spans from beam to beam minus the web thickness and has a depth equal to the distance from the top of the beam to the bottom of the web. Therefore, the concentrated load to be applied at the locations above is:

$$\begin{aligned}DC_{\text{diaphragm}} &= 0.15(10/12)[9.667 - (8/12)](72 - 18)/12 \\ &= 5.0625 \text{ k/girder}\end{aligned}$$

The exterior girder only resists half of this loading.

Parapet weight

According to the S4.6.2.2.1, the parapet weight may be distributed equally to all girders in the cross section.

Parapet cross-sectional area = 4.33 ft^2

$$\begin{aligned} DC_{\text{parapet}} &= 4.33(0.150) = 0.650 \text{ k/ft} \\ &= 0.650/6 \text{ girders} \\ &= 0.108 \text{ k/ft/girder for one parapet} \end{aligned}$$

Therefore, the effect of two parapets yields:

$$DC_{\text{parapet}} = 0.216 \text{ k/ft per girder}$$

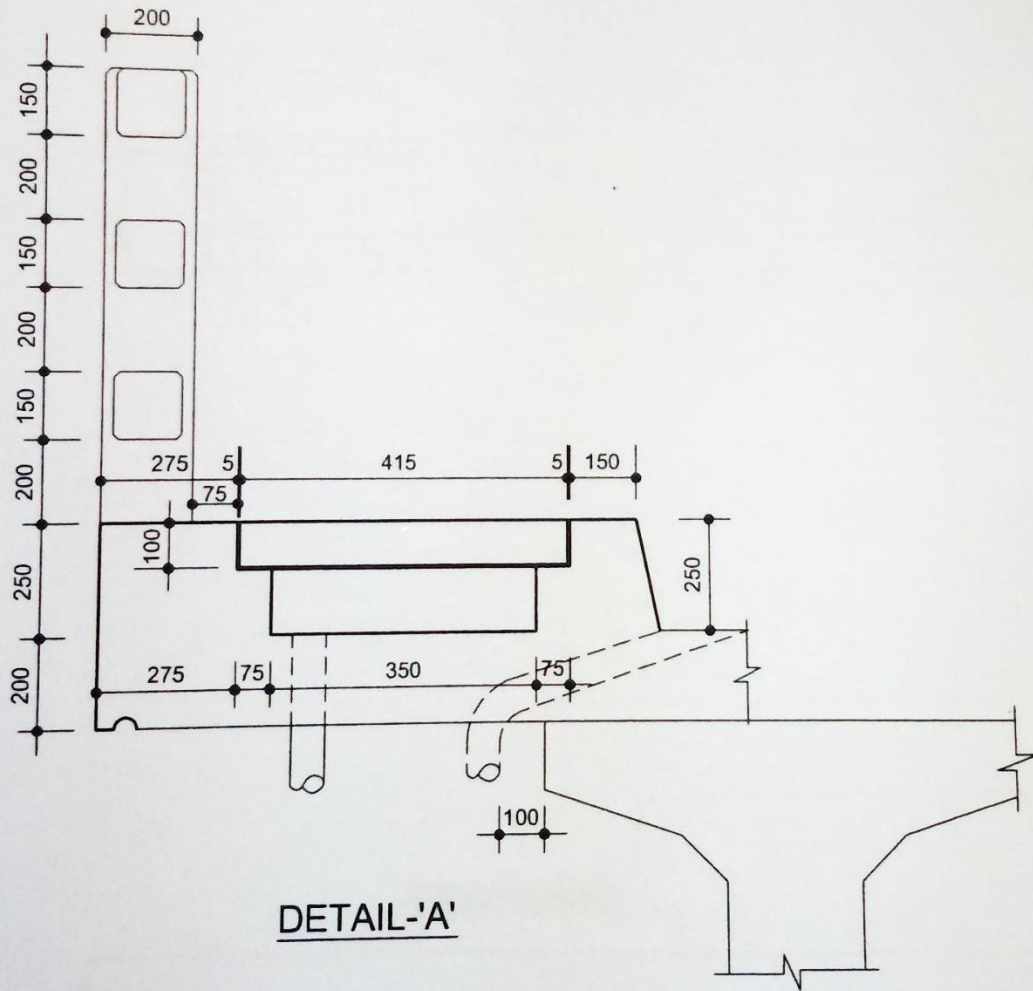

Future wearing surface

Interior girder

$$\text{Weight/ft}^2 = 0.030 \text{ k/ft}^2$$

$$\text{Width} = 9.667 \text{ ft.}$$

$$\begin{aligned} DW_{\text{FWS (I)}} &= 0.030(9.667) \\ &= 0.290 \text{ k/ft/girder} \end{aligned}$$

Exterior Girder



$$\text{Weight/ft}^2 = 0.030 \text{ k/ft}^2$$

$$\begin{aligned} \text{Width} &= \text{slab width} - \text{parapet width} \\ &= 8.35 - 1.6875 \\ &= 6.663 \text{ ft.} \end{aligned}$$

$$\begin{aligned} DW_{\text{FWS (E)}} &= 0.030(6.663) \\ &= 0.200 \text{ k/ft/girder} \end{aligned}$$

Interior Girder: Live load moments

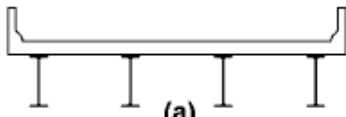
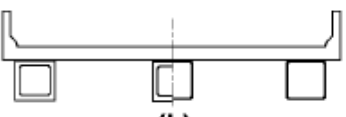
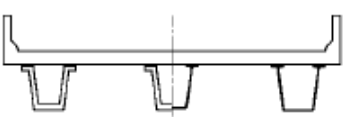
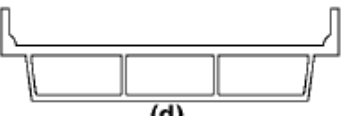
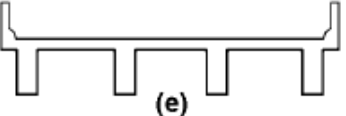
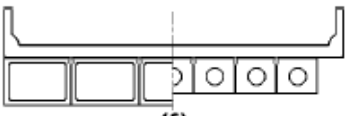
Table 4.6.2.2.1-1—Common Deck Superstructures Covered in Articles 4.6.2.2.2 and 4.6.2.2.3

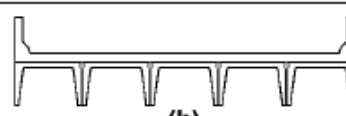
Supporting Components	Type Of Deck	Typical Cross-Section
Steel Beam	Cast-in-place concrete slab, precast concrete slab, steel grid, glued/spiked panels, stressed wood	 (a)
Closed Steel or Precast Concrete Boxes	Cast-in-place concrete slab	 (b)
Open Steel or Precast Concrete Boxes	Cast-in-place concrete slab, precast concrete deck slab	 (c)
Cast-in-Place Concrete Multicell Box	Monolithic concrete	 (d)
Cast-in-Place Concrete Tee Beam	Monolithic concrete	 (e)
Precast Solid, Voided or Cellular Concrete Boxes with Shear Keys	Cast-in-place concrete overlay	 (f)
Precast Solid, Voided, or Cellular Concrete Box with Shear Keys and with or without Transverse Post-Tensioning	Integral concrete	 (g)
Precast Concrete Channel Sections with Shear Keys	Cast-in-place concrete overlay	 (h)

Continued on next page

Table 4.6.2.2.1-1 (continued)—Common Deck Superstructures Covered in Articles 4.6.2.2.2 and 4.6.2.2.3

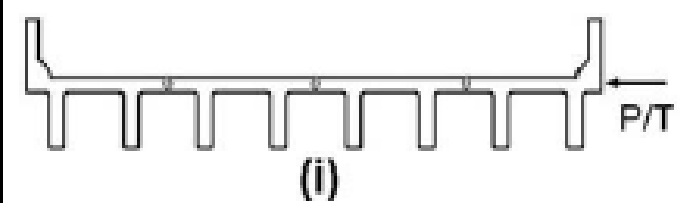
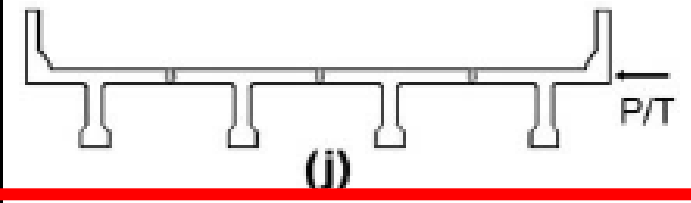
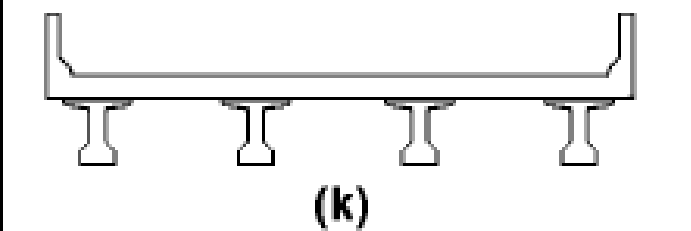
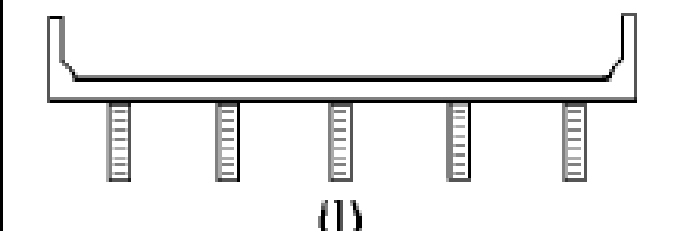
Supporting Components	Type Of Deck	Typical Cross-Section
Precast Concrete Double Tee Section with Shear Keys and with or without Transverse Post-Tensioning	Integral concrete	 <p>(i)</p>
Precast Concrete Tee Section with Shear Keys and with or without Transverse Post-Tensioning	Integral concrete	 <p>(j)</p>
Precast Concrete I or Bulb-Tee Sections	Cast-in-place concrete, precast concrete	 <p>(k)</p>
Wood Beams	Cast-in-place concrete or plank, glued/spiked panels or stressed wood	 <p>(l)</p>

Interior Girder: Live load moments

Table 4.6.2.2.2b-1—Distribution of Live Loads for Moment in Interior Beams

Type of Superstructure	Applicable Cross-Section from Table 4.6.2.2.1-1	Distribution Factors	Range of Applicability
Wood Deck on Wood or Steel Beams	a, l	See Table 4.6.2.2.2a-1	
Concrete Deck on Wood Beams	1	One Design Lane Loaded: $S/12.0$ Two or More Design Lanes Loaded: $S/10.0$	$S \leq 6.0$
Concrete Deck, Filled Grid, Partially Filled Grid, or Unfilled Grid Deck Composite with Reinforced Concrete Slab on Steel or Concrete Beams; Concrete T-Beams, T- and Double T-Sections	a, e, k and also i, j if sufficiently connected to act as a unit	One Design Lane Loaded: $0.06 + \left(\frac{S}{14}\right)^{0.4} \left(\frac{S}{L}\right)^{0.3} \left(\frac{K_g}{12.0 L t_s^3}\right)^{0.1}$ Two or More Design Lanes Loaded: $0.075 + \left(\frac{S}{9.5}\right)^{0.6} \left(\frac{S}{L}\right)^{0.2} \left(\frac{K_g}{12.0 L t_s^3}\right)^{0.1}$ use lesser of the values obtained from the equation above with $N_b = 3$ or the lever rule	$3.5 \leq S \leq 16.0$ $4.5 \leq t_s \leq 12.0$ $20 \leq L \leq 240$ $N_b \geq 4$ $10,000 \leq K_g \leq 7,000,000$ $N_b = 3$
Cast-in-Place Concrete	d	One Design Lane Loaded:	$7.0 \leq S \leq 13.0$

Table 4.6.2.2.1-2—Constant Values for Articles 4.6.2.2.2 and 4.6.2.2.3

Equation Parameters	Table Reference	Simplified Value			
		a	e	k	f,g,i,j
$\left(\frac{K_g}{12.0Lt_s^3}\right)^{0.1}$	4.6.2.2.2b-1	1.02	1.05	1.09	—
$\left(\frac{K_g}{12.0Lt_s^3}\right)^{0.25}$	4.6.2.2.2e-1	1.03	1.07	1.15	—
$\left(\frac{12.0Lt_s^3}{K_g}\right)^{0.3}$	4.6.2.2.3c-1	0.97	0.93	0.85	—
$\frac{I}{J}$	4.6.2.2.2b-1, 4.6.2.2.3a-1	—	—	—	$0.54\left(\frac{d}{b}\right)+0.16$

Table 3.6.1.1.2-1—Multiple Presence Factors, m

Number of Loaded Lanes	Multiple Presence Factors, m
1	1.20
2	1.00
3	0.85
>3	0.65

Required information:

AASHTO Type I-Beam (28/72)

Noncomposite beam area, A_g = 1,085 in²

Noncomposite beam moment of inertia, I_g = 733,320 in⁴

Deck slab thickness, t_s = 8 in.

Span length, L = 110 ft.

Girder spacing, S = 9 ft. - 8 in.

Modulus of elasticity of the beam, E_B = 4,696 ksi (S5.4.2.4)

Modulus of elasticity of the deck, E_D = 3,834 ksi (S5.4.2.4)

C.G. to top of the basic beam = 35.62 in.

C.G. to bottom of the basic beam = 36.38 in.

Calculate n , the modular ratio between the beam and the deck.

$$\begin{aligned} n &= E_B/E_D && \text{(S4.6.2.2.1-2)} \\ &= 4,696/3,834 \\ &= 1.225 \end{aligned}$$

Calculate e_g , the distance between the center of gravity of the noncomposite beam and the deck. Ignore the thickness of the haunch in determining e_g . It is also possible to ignore the integral wearing surface, i.e., use $t_s = 7.5$ in. However the difference in the distribution factor will be minimal.

$$\begin{aligned} e_g &= NA_{YT} + t_s/2 \\ &= 35.62 + 8/2 \\ &= 39.62 \text{ in.} \end{aligned}$$

Calculate K_g , the longitudinal stiffness parameter.

$$\begin{aligned} K_g &= n(I + Ae_g^2) && \text{(S4.6.2.2.1-1)} \\ &= 1.225[733,320 + 1,085(39.62)^2] \\ &= 2,984,704 \text{ in}^4 \end{aligned}$$

Calculate the moment distribution factor for an interior beam with two or more design lanes loaded using Table S4.6.2.2.2b-1.

$$D_M = 0.075 + (S/9.5)^{0.6} (S/L)^{0.2} (K_g/12.0L t_s^3)^{0.1}$$

$$\begin{aligned} &= 0.075 + (9.667/9.5)^{0.6} (9.667/110)^{0.2} [2,984,704/[12(110)(8)^3]]^{0.1} \\ &= 0.796 \text{ lane} \qquad (1) \end{aligned}$$

Calculate the moment distribution factor for an interior beam with one design lane loaded using Table S4.6.2.2.2b-1.

$$\begin{aligned} D_M &= 0.06 + (S/14)^{0.4} (S/L)^{0.3} (K_g/12.0L t_s^3)^{0.1} \\ &= 0.06 + (9.667/14)^{0.4} (9.667/110)^{0.3} [2,984,704/[12(110)(8)^3]]^{0.1} \\ &= 0.542 \text{ lane} \qquad (2) \end{aligned}$$

Notice that the distribution factor calculated above for a single lane loaded already includes the 1.2 multiple presence factor for a single lane, therefore, this value may be used for the service and strength limit states. However, multiple presence factors should not be used for the fatigue limit state. Therefore, the multiple presence factor of 1.2 for the single lane is required to be removed from the value calculated above to determine the factor used for the fatigue limit state.

For single-lane loading to be used for fatigue design, remove the multiple presence factor of 1.2.

$$\begin{aligned} D_M &= 0.542/1.2 \\ &= 0.452 \text{ lane} \end{aligned}$$

(3)



Interior Girder: Live load shears

Table 4.6.2.2.3a-1—Distribution of Live Load for Shear in Interior Beams

Type of Superstructure	Applicable Cross-Section from Table 4.6.2.2.1-1	One Design Lane Loaded	Two or More Design Lanes Loaded	Range of Applicability
Wood Deck on Wood or Steel Beams	a, 1	See Table 4.6.2.2.2a-1		
Concrete Deck on Wood Beams	1	Lever Rule	Lever Rule	N/A
Concrete Deck, Filled Grid, Partially Filled Grid, or Unfilled Grid Deck Composite with Reinforced Concrete Slab on Steel or Concrete Beams; Concrete T-Beams, T-and Double T-Sections	a, e, k and also i, j if sufficiently connected to act as a unit	$0.36 + \frac{S}{25.0}$	$0.2 + \frac{S}{12} - \left(\frac{S}{35}\right)^{2.0}$	$3.5 \leq S \leq 16.0$ $20 \leq L \leq 240$ $4.5 \leq t_s \leq 12.0$ $N_b \geq 4$
		Lever Rule	Lever Rule	$N_b = 3$
Cast-in-Place Concrete Multicell Box	d	$\left(\frac{S}{9.5}\right)^{0.6} \left(\frac{d}{12.0L}\right)^{0.1}$	$\left(\frac{S}{7.3}\right)^{0.9} \left(\frac{d}{12.0L}\right)^{0.1}$	$6.0 \leq S \leq 13.0$ $20 \leq L \leq 240$ $35 \leq d \leq 110$ $N_c \geq 3$

According to S4.6.2.2.3c, a skew correction factor for support shear at the obtuse corner must be applied to the distribution factor of all skewed bridges. The value of the correction factor is calculated using Table S4.6.2.2.3c-1

$$\begin{aligned} \text{SC} &= 1.0 + 0.20(12.0L_t^3/K_g)^{0.3} \tan \theta \\ &= 1.0 + 0.20[[12.0(110)(8)^3]/2,984,704]^{0.3} \tan 20 \\ &= 1.047 \end{aligned}$$



Calculate the shear distribution factor for an interior beam with two or more design lanes loaded using Table S4.6.2.2.3a-1.

$$D_V = 0.2 + (S/12) - (S/35)^2$$

$$= 0.2 + (9.667/12) - (9.667/35)^2$$

$$= 0.929 \text{ lane}$$

Apply the skew correction factor:

$$\begin{aligned} D_V &= 1.047(0.929) \\ &= 0.973 \text{ lane} \end{aligned} \quad (4)$$



Calculate the shear distribution factor for an interior beam with one design lane loaded using Table S4.6.2.2.3a-1.

$$\begin{aligned} D_V &= 0.36 + (S/25.0) \\ &= 0.36 + (9.667/25.0) \\ &= 0.747 \text{ lane} \end{aligned}$$

Apply the skew correction factor:

$$D_V = 1.047(0.747) \\ = 0.782 \text{ lane} \quad (5) \quad \times$$

For single-lane loading to be used for fatigue design, remove the multiple presence factor of 1.2.

$$D_V = 0.782/1.2 \\ = 0.652 \text{ lane} \quad (6) \quad \times$$

From (1) and (2), the service and strength limit state moment distribution factor for the interior girder is equal to the larger of 0.796 and 0.542 lane. Therefore, the moment distribution factor is 0.796 lane.

From (3):

The fatigue limit state moment distribution factor is 0.452 lane

From (4) and (5), the service and strength limit state shear distribution factor for the interior girder is equal to the larger of 0.973 and 0.782 lane. Therefore, the shear distribution factor is 0.973 lane.

From (6):

The fatigue limit state shear distribution factor is 0.652 lane

Table 5.1-1 – Summary of Service and Strength Limit State Distribution Factors

	Load Case	Moment interior beams	Moment exterior beams	Shear interior beams	Shear exterior beams
Distribution factors from Tables in S4.6.2.2.2	Multiple lanes loaded	0.796	0.772	0.973	0.762
	Single lane loaded	0.542	0.806	0.782	0.845
Additional check for rigidly connected girders	Multiple lanes loaded	NA	0.776	NA	0.776
	Single lane loaded	NA	0.572	NA	0.572
Design value		0.796	0.806	0.973	0.845

Table 5.3-1 - Summary of Unfactored Moments

Interior girder, Span 1 shown, Span 2 mirror image

Location*	Noncomposite					Composite		Live Load + IM	
	Girder		Slab and Haunch	Exterior Diaphragm	Total Noncomp.	Parapet	FWS	Positive HL-93	Negative HL-93
	**	***							
(ft.)	(k-ft)	(k-ft)	(k-ft)	(k-ft)	(k-ft)	(k-ft)	(k-ft)	(k-ft)	(k-ft)
0	47	0	0	0	0	0	0	0	0
1.0	108	61	62	3	125	9	12	92	-11
5.5	368	322	325	14	661	46	62	476	-58
11.0	656	609	615	28	1,252	85	114	886	-116
16.5	909	863	871	42	1,776	118	158	1,230	-174
22.0	1,128	1,082	1,093	56	2,230	144	193	1,509	-233
27.5	1,313	1,267	1,279	70	2,616	164	220	1,724	-291
33.0	1,464	1,417	1,432	84	2,933	177	237	1,882	-349
38.5	1,580	1,534	1,549	98	3,181	183	246	1,994	-407
44.0	1,663	1,616	1,633	111	3,360	183	246	2,047	-465
49.5	1,711	1,664	1,681	125	3,471	177	237	2,045	-523
54.5	1,725	1,679	1,696	138	3,512	165	222	2,015	-576
55.0	1,725	1,678	1,695	137	3,511	164	220	2,010	-581
60.5	1,705	1,658	1,675	123	3,456	144	194	1,927	-640
66.0	1,650	1,604	1,620	109	3,333	118	159	1,794	-698
71.5	1,562	1,515	1,531	95	3,141	86	115	1,613	-756
77.0	1,439	1,392	1,407	81	2,880	46	62	1,388	-814
82.5	1,282	1,236	1,248	67	2,551	1	1	1,124	-872
88.0	1,091	1,044	1,055	53	2,152	-52	-69	825	-1,124
93.5	865	819	827	39	1,686	-110	-148	524	-1,223
99.0	606	560	565	25	1,150	-176	-236	297	-1,371
104.5	312	266	268	11	546	-248	-332	113	-1,663
108.0	110	61	62	3	125	-297	-398	33	-1,921
109.0	47	0	0	0	0	-311	-418	15	-2,006
Span 2 - 0	-	0	0	0	0	-326	-438	0	-2,095

* Distance from the centerline of the end bearing

** Based on the simple span length of 110.5 ft. and supported at the ends of the girders. These values are used to calculate stresses at transfer.

*** Based on the simple span length of 109 ft. and supported at the centerline of bearings. These values are used to calculate the final stresses.

Unfactored Moments

	Non-composite				Composite		
	Girder	Slab	Diaphragm	Total NC	Sidewalk Railing	Wearing	LL+IM
0							
0.1L							
0.2L							
0.3L							
0.4L							
0.5L							
Max							

Table 5.3-2 – Summary of Factored Moments

Interior girder, Span 1 shown, Span 2 mirror image

Location*	Strength I	Service I **		Service III **	
		NC	Comp.	NC	Comp.
(ft.)	(k-ft)	(k-ft)	(k-ft)	(k-ft)	(k-ft)
0	0	0	0	0	0
1.0	346	125	112	125	94
5.5	1,809	661	584	661	488
11.0	3,394	1,252	1,085	1,252	908
16.5	4,756	1,776	1,506	1,776	1,260
22.0	5,897	2,230	1,846	2,230	1,544
27.5	6,821	2,616	2,108	2,616	1,763
33.0	7,536	2,933	2,296	2,933	1,920
38.5	8,063	3,181	2,423	3,181	2,024
44.0	8,381	3,360	2,477	3,360	2,067
49.5	8,494	3,471	2,459	3,471	2,050
54.5	8,456	3,512	2,402	3,512	1,999
55.0	8,440	3,511	2,394	3,511	1,992
60.5	8,163	3,456	2,265	3,456	1,880
66.0	7,690	3,333	2,070	3,333	1,712
71.5	7,027	3,141	1,813	3,141	1,490
77.0	6,181	2,880	1,497	2,880	1,219
82.5	5,158	2,551	1,126	2,551	901
88.0	3,967	2,152	-1,245	2,152	-1,020
93.5	2,664	1,686	-1,481	1,686	-1,237
99.0	-1,535	1,150	-1,783	1,150	-1,509
104.5	-3,035	546	-2,242	546	-1,910
108.0	-4,174	125	-2,616	125	-2,232
109.0	-4,525	0	-2,734	0	-2,333
Span 2 - 0	-4,729	0	-2,858	0	-2,439

Load Factor Combinations

Strength I = 1.25(DC) + 1.5(DW) + 1.75(LL + IM)

Service I = 1.0[DC + DW + (LL + IM)]

Service III = 1.0(DC + DW) + 0.8(LL + IM)

Factored Moments					
		Service I		Service III	
Location	Strength I	NC	Comp	NC	Comp

$$\begin{aligned}
 \text{Strength I} &= 1.25DC + 1.5DW + 1.75(LL+IM) \\
 &= 1.25(\text{Girder} + \text{slab} + \text{Dia}) \\
 &\quad + 1.5(\text{wearing} + \text{sidewalk}) \\
 &\quad + 1.75(LL+IM)
 \end{aligned}$$

$$\begin{cases}
 \text{Service I (NC)} = \text{Total NC} = \text{Girder} + \text{slab} + \text{Dia} \\
 \text{Service I (Comp)} = \text{Sidewalk} + \text{Railing} + \text{Wearing} + (LL+IM)
 \end{cases}$$

$$\begin{cases}
 \text{Service III (NC)} = \text{Total NC} = \text{Girder} + \text{slab} + \text{Dia} \\
 \text{Service III (Comp)} = \text{Sidewalk} + \text{Railing} + \text{Wearing} + 0.8 * (LL+IM)
 \end{cases}$$

Table 5.3-3 - Summary of Unfactored Shear

Interior girder, Span 1 shown, Span 2 mirror image

Location*	Noncomposite				Composite		Live Load + IM	
	Girder	Slab and Haunch	Exterior Diaphragm	Total Noncomp.	Parapet	FWS	Positive HL-93	Negative HL-93
(ft.)	(k)	(k)	(k)	(k)	(k)	(k)	(k)	(k)
0	61.6	62.2	2.5	126.4	8.9	12.0	113.3	-12.9
1.0	60.5	61.1	2.5	124.1	8.7	11.7	111.7	-12.9
5.5	55.4	55.9	2.5	113.9	7.7	10.4	104.3	-13.0
11.0	49.2	49.7	2.5	101.4	6.5	8.8	95.5	-13.4
16.5	43.0	43.4	2.5	88.9	5.4	7.2	86.9	-15.9
22.0	36.7	37.1	2.5	76.4	4.2	5.6	78.7	-20.6
27.5	30.5	30.8	2.5	63.9	3.0	4.0	70.8	-26.0
33.0	24.3	24.6	2.5	51.4	1.8	2.4	63.1	-32.8
38.5	18.1	18.3	2.5	38.9	0.6	0.8	55.9	-39.8
44.0	11.9	12.0	2.5	26.4	-0.6	-0.8	48.9	-46.8
49.5	5.7	5.7	2.5	13.9	-1.8	-2.4	42.4	-54.0
54.5	0	0	-2.5	-2.5	-2.9	-3.8	36.8	-60.5
55.0	-0.6	-0.6	-2.5	-3.7	-3.0	-4.0	36.2	-61.2
60.5	-6.8	-6.9	-2.5	-16.2	-4.2	-5.6	30.4	-68.4
66.0	-13.0	-13.1	-2.5	-28.7	-5.3	-7.2	25.0	-75.7
71.5	-19.2	-19.4	-2.5	-41.2	-6.5	-8.8	20.0	-82.9
77.0	-25.4	-25.7	-2.5	-53.7	-7.7	-10.4	15.4	-90.1
82.5	-31.7	-32.0	-2.5	-66.1	-8.9	-12.0	11.3	-97.3
88.0	-37.9	-38.3	-2.5	-78.6	-10.1	-13.6	8.2	-104.3
93.5	-44.1	-44.5	-2.5	-91.1	-11.3	-15.1	5.5	-111.3
99.0	-50.3	-50.8	-2.5	-103.6	-12.5	-16.7	3.2	-118.0
104.5	-56.5	-57.1	-2.5	-116.1	-13.7	-18.3	1.2	-124.7
108.0	-60.5	-61.1	-2.5	-124.1	-14.4	-19.4	0.4	-128.7
109.0	-61.6	-62.2	-2.5	-126.4	-14.6	-19.6	0.2	-129.9
Span 2 - 0	0	0	0	0	-14.8	-19.9	0	-131.1

* Distance from the centerline of the end bearing

Table 5.3-4 – Summary of Factored Shear

Interior girder, Span 1 shown, Span 2 mirror image

Location*	Strength I	Service I	Service III
(ft.)	(k)	(k)	(k)
0	385.4	260.6	237.9
1.0	379.0	256.2	233.8
5.5	350.0	236.2	215.4
11.0	315.1	212.1	193.0
16.5	280.7	188.3	170.9
22.0	246.8	164.8	149.1
27.5	213.4	141.6	127.5
33.0	180.6	118.7	106.1
38.5	148.3	96.2	85.0
44.0	116.7	74.0	64.2
49.5	85.7	52.1	43.6
54.5	-118.4	-69.7	-57.6
55.0	-121.3	-71.8	-59.6
60.5	-153.5	-94.3	-80.6
66.0	-185.7	-116.9	-101.7
71.5	-217.9	-139.4	-122.8
77.0	-250.0	-161.8	-143.8
82.5	-282.0	-184.3	-164.8
88.0	-313.8	-206.6	-185.7
93.5	-345.4	-228.8	-206.6
99.0	-376.8	-250.9	-227.3
104.5	-407.9	-272.8	-247.8
108.0	-427.4	-286.6	-260.8
109.0	-433.0	-290.5	-264.5
Span 2 - 0	-277.8	-165.8	-139.6

Load Factor Combinations



Strength I = 1.25(DC) + 1.5(DW) + 1.75(LL + IM)

Service I = 1.0[DC + DW + (LL + IM)]

Service III = 1.0(DC + DW) + 0.8(LL + IM)

* Distance from the centerline of the end bearing

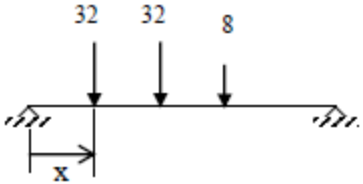
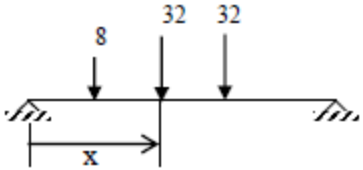
Live Load Placement – Design Equation

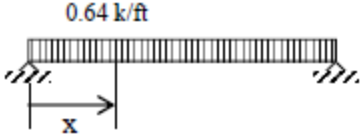
Case	Load Configuration	Moments (kips-ft) and shears (kips)	Loading and limitations (x and l in feet)
A		$M(x) = Px \left[4.5 \left(1 - \frac{x}{l} \right) - \frac{42}{l} \right]$ $V(x) = P \left[4.5 \left(1 - \frac{x}{l} \right) - \frac{42}{l} \right]$	Truck loading $P = 16$ kips $M_A \geq M_B$ for: $l > 28$ $x \leq l/3$ $x + 28 \leq l$ $V_A > V_B$ for any x
B		$M(x) = Px \left[4.5 \left(1 - \frac{x}{l} \right) - \frac{21}{l} - \frac{7}{x} \right]$ $V(x) = P \left[4 - 4.5 \frac{x}{l} - \frac{21}{l} \right]$	Truck loading $P = 16$ kips $M_B \geq M_A$ for: $l > 28$ $x > l/3$ $14 \leq x \leq l/2$
C		$M(x) = 50x \left(1 - \frac{x}{l} - \frac{2}{l} \right)$ $V(x) = 50 \left(1 - \frac{x}{l} - \frac{2}{l} \right)$	Tandem loading is more severe than truck loading for $l \leq 37$ ft
D		$M(x) = 0.64x \frac{(l-x)}{2}$ $V(x) = 0.64 \left(\frac{l}{2} - x \right)$	Lane loading

Live Load Placement – Design Equation

- If we combine the truck/tandem load with uniform load, we can get the following equations for maximum moment in spans

SI units:

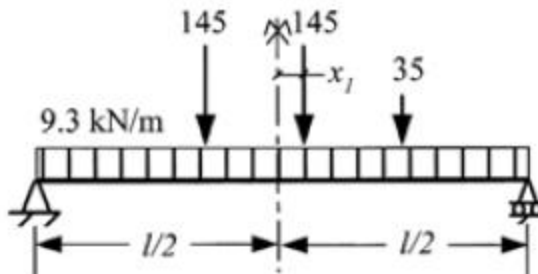
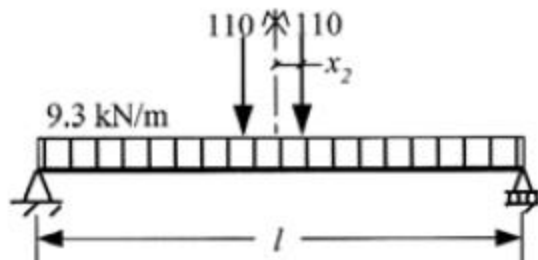
Combination*	Load configuration	Absolute maximum moment in span (kN-m)
1	<p>HS20 truck + uniform lane load:</p> 	$(M_{max})_{LL+IM} = (1 + I)M_{truck} + M_{unif-lane}$ $M_{truck} = 81.25l + \frac{x_1}{l}(473 - 325x_1) - 387$ $M_{unif-lane} = 1.1625(l^2 - 4x_1^2)$ <p>where $x_1 = \frac{473}{650 + 9.3l}$ m</p>
2	<p>Tandem + uniform lane load:</p> 	$(M_{max})_{LL+IM} = (1 + I)M_{tandem} + M_{unif-lane}$ $M_{tandem} = 55l + \frac{x_2}{l}(132 - 220x_2) - 66$ $M_{unif-lane} = 1.1625(l^2 - 4x_2^2)$ <p>where $x_2 = \frac{132}{440 + 9.3l}$ m</p>

* Combination 1 is more severe than Combination 2 for $l > 11.75$ m.

Table of Maximum Moments, Shears, and Reactions Simple Spans,
One Lane **With** Dynamic Load Allowance (cont.)

Span(ft)		Moment (k-ft)		End Shear and End Reaction (k)		Span(ft)		Moment (k-ft)		End Shear and End Reaction (k)	
42	—————	774.2	a	87.9	a	100	—————	2821.6	a	118.8	a
44	—————	835.8	a	89.5	a	110	—————	3229.0	a	122.8	a
46	—————	898.1	a	91.1	a	120	—————	3652.4	a	126.7	a
48	—————	961.0	a	92.5	a	130	—————	4091.8	a	130.5	a
50	—————	1024.6	a	93.9	a	140	—————	4547.2	a	134.2	a
52	—————	1088.8	a	95.2	a	150	—————	5018.6	a	137.8	a
54	—————	1153.6	a	96.5	a	160	—————	5506.0	a	141.4	a
56	—————	1219.1	a	97.7	a	170	—————	6009.4	a	144.9	a
58	—————	1285.2	a	98.9	a	180	—————	6528.8	a	148.4	a
60	—————	1352.0	a	100.1	a	190	—————	7064.2	a	151.9	a
62	—————	1419.4	a	101.2	a	200	—————	7615.6	a	155.3	a
64	—————	1487.4	a	102.3	a	220	—————	8766.4	a	162.1	a
66	—————	1556.1	a	103.3	a	240	—————	9981.2	a	168.8	a
68	—————	1625.4	a	104.4	a	260	—————	11260.0	a	175.5	a
70	—————	1695.4	a	105.4	a	280	—————	12602.8	a	182.2	a
75	—————	1873.1	a	107.8	a	300	—————	14009.6	a	188.8	a
80	—————	2054.8	a	110.2	a						
85	—————	2240.5	a	112.4	a						
90	—————	2430.2	a	114.6	a						
95	—————	2623.9	a	116.8	a						

a controlled by Design Truck + Lane Loading

b controlled by Design Tandem + Lane Loading

Before next class

- Find all dead and superimposed dead
- Dead
 - Self wt of girder (consider end block =depth of girder, h , gradual over $0.5h$)
 - Wt of slab
 - Diaphragm (2 on bearing, intermediate spacing $<40\text{ft}$)
- Superimposed
 - Future wearing
 - Sidewalk and railing (may assume 0.6 kip/ft each side)
posts are spaced at 5ft . ~~Only for exterior girder.~~

- Find Live load distribution factors
 - Two lane and one lane
 - Moments and shear
- Find moments and shear along span (0.1L interval)
 - Truck load, use influence line, check with formula
 - Lane load
 - ~~Sidewalk > 2ft live load 75 psf, for exterior girder~~
- Live Load on a girder = $DM * (Truck * IM + Lane)$

- Prepare tables for interior girder
 - Unfactored moments
 - Unfactored shear
 - Factored (Strength I, Service I,III) Moments
 - Factored (Strength I, Service I,III) Shears

DESIGN

- Moments, shears at different sections obtained for non-composite and composite
- Sectional properties- A , I , y_b , y_t , S_b , S_t , r , k_t , k_b obtained for non-composite and composite
- Allowable stresses needed

- Strand properties
- Tensile strength= 1860MPa=270ksi
- Yield strength= 1670MPa= 242ksi

		Nominal diameter (mm)	Nominal area (mm ²)	Nominal mass (kg/m)	Yield strength (N/mm ²)	Tensile strength (N/mm ²)	Minimum breaking load (kN)	Modulus of elasticity (kN/mm ²)	Relaxation ¹ (class 2 or low relaxation)
7-wire strand low-relaxation									
13 mm (0.5")	Euronorm 138-79, or BS 5896: 1980, Super	12.9	100	0.785	1580	1860	186	195	2.5%
	Euronorm 138-79, or BS 5896: 1980, Standard	12.5	93	0.73	1500	1770	164	195	2.5%
	Euronorm 138-79, or BS 5896: 1980, Drawn	12.7	112	0.89	1580	1860	209	195	2.5%
	ASTM A416-85, Grade 270	12.7	98.7	0.775	1670	1860	183.7	195	2.5%
15 mm (0.6")	Euronorm 138-79, or BS 5896: 1980, Super	15.7	150	1.18	1500	1770	265	195	2.5%
	Euronorm 138-79, or BS 5896: 1980, Standard	15.2	139	1.09	1420	1670	232	195	2.5%
	Euronorm 138-79, or BS 5896: 1980, Drawn	15.2	165	1.295	1550	1820	300	195	2.5%
	ASTM A416-85, Grade 270	15.2	140	1.10	1670	1860	260.7	195	2.5%
Stress bars									
20 mm	BS 4486: 1980	20	314	2.39	835	1030	323	170/205	3.5%
25 mm	BS 4486: 1980	25	491	3.9	835	1030	505	170/205	3.5%
32 mm	BS 4486: 1980	32	804	6.66	835	1030	828	170/205	3.5%
40 mm	BS 4486: 1980	40	1257	10	835	1030	1300	170/205	3.5%
50 mm	BS 4486: 1980	50	1963	16.02	835	1030	2022	170/205	3.5%
Cold-drawn wire									
7 mm	BS 5896: 1980	7	38.5	302	1300	1570	60.4	205	2.5%
	BS 5896: 1980				1390	1670	64.3	205	2.5%
5 mm	BS 5896: 1980	5	19.6	154	1390	1670	32.7	205	2.5%
	BS 5896: 1980				1470	1770	34.7	205	2.5%

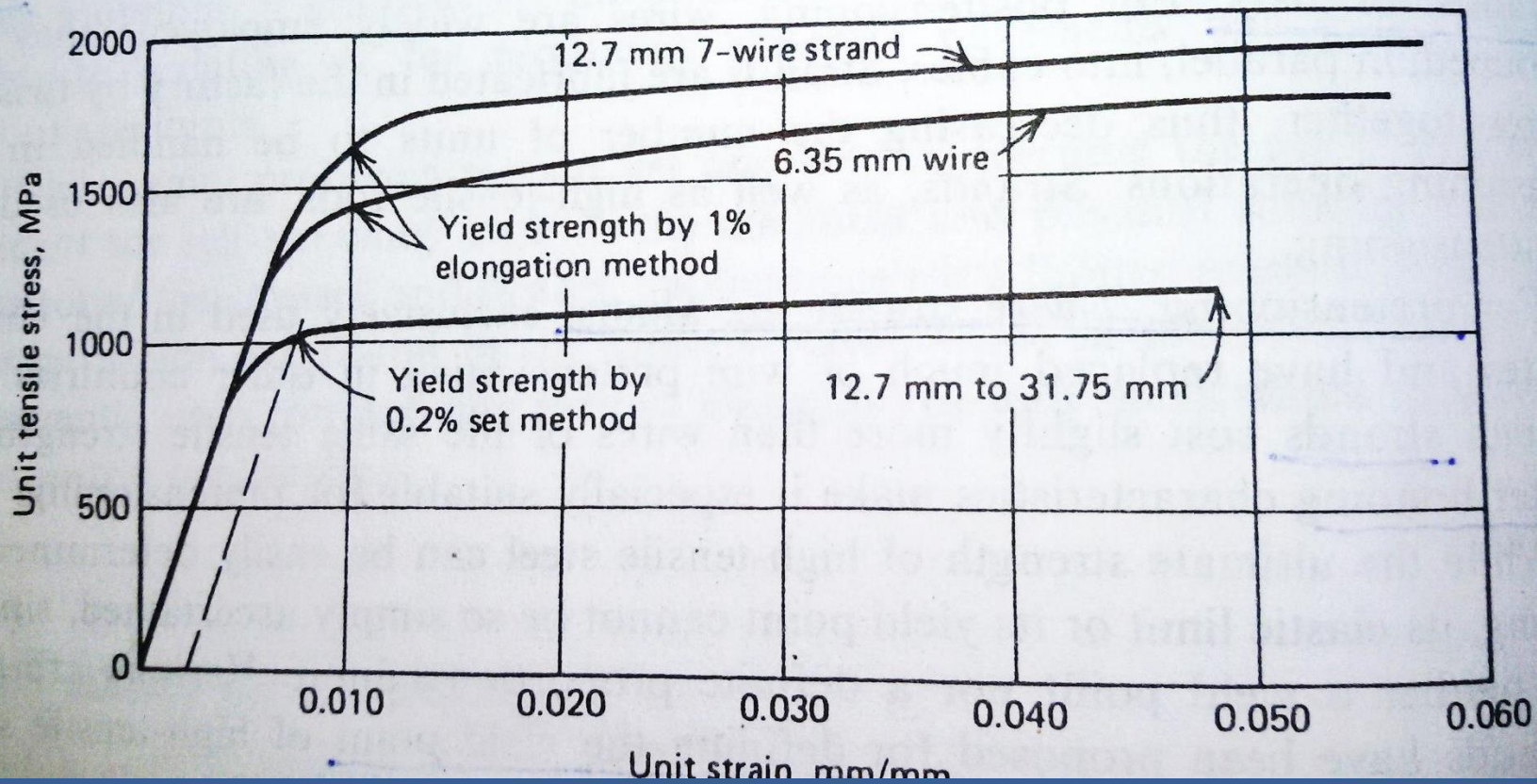

Table 5.9.3-1—Stress Limits for Prestressing Tendons

Condition	Tendon Type		
	Stress-Relieved Strand and Plain High-Strength Bars	Low Relaxation Strand	Deformed High-Strength Bars
Pretensioning			
Immediately prior to transfer (f_{pbt})	$0.70f_{pu}$	$0.75f_{pu}$	—
At service limit state after all losses (f_{pe})	$0.80f_{py}$	$0.80f_{py}$	$0.80f_{py}$
Post-Tensioning			
Prior to seating—short-term f_{pbt} may be allowed	$0.90f_{py}$	$0.90f_{py}$	$0.90f_{py}$
At anchorages and couplers immediately after anchor set	$0.70f_{pu}$	$0.70f_{pu}$	$0.70f_{pu}$
Elsewhere along length of member away from anchorages and couplers immediately after anchor set	$0.70f_{pu}$	$0.74f_{pu}$	$0.70f_{pu}$
At service limit state after losses (f_{pe})	$0.80f_{py}$	$0.80f_{py}$	$0.80f_{py}$

Table 5.9.4.2.1-1—Compressive Stress Limits in Prestressed Concrete at Service Limit State after Losses, Fully Prestressed Components

Location	Stress Limit
<ul style="list-style-type: none"> In other than segmentally constructed bridges due to the sum of effective prestress and permanent loads 	$0.45f'_c$ (ksi)
<ul style="list-style-type: none"> In segmentally constructed bridges due to the sum of effective prestress and permanent loads 	$0.45f'_c$ (ksi)
<ul style="list-style-type: none"> Due to the sum of effective prestress, permanent loads, and transient loads as well as during shipping and handling 	$0.60 \phi_w f'_c$ (ksi)

Table 5.9.4.2.2-1—Tensile Stress Limits in Prestressed Concrete at Service Limit State after Losses, Fully Prestressed Components

Bridge Type	Location	Stress Limit
Other Than Segmentally Constructed Bridges	Tension in the Precompressed Tensile Zone Bridges, Assuming Uncracked Sections	
	<ul style="list-style-type: none"> For components with bonded prestressing tendons or reinforcement that are subjected to not worse than moderate corrosion conditions 	0.19√f'c (ksi)
	<ul style="list-style-type: none"> For components with bonded prestressing tendons or reinforcement that are subjected to severe corrosive conditions 	0.0948√f'c (ksi)
	<ul style="list-style-type: none"> For components with unbonded prestressing tendons 	No tension
Segmentally Constructed Bridges	Longitudinal Stresses through Joints in the Precompressed Tensile Zone	
	<ul style="list-style-type: none"> Joints with minimum bonded auxiliary reinforcement through the joints sufficient to carry the calculated longitudinal tensile force at a stress of 0.5 fy; internal tendons or external tendons 	0.0948√f'c (ksi)
	<ul style="list-style-type: none"> Joints without the minimum bonded auxiliary reinforcement through joints 	No tension
	Transverse Stresses through Joints	
	<ul style="list-style-type: none"> Tension in the transverse direction in precompressed tensile zone 	0.0948√f'c (ksi)
Stresses in Other Areas		
	<ul style="list-style-type: none"> For areas without bonded reinforcement 	No tension
	<ul style="list-style-type: none"> In areas with bonded reinforcement sufficient to resist the tensile force in the concrete computed assuming an uncracked section, where reinforcement is proportioned using a stress of 0.5 fy, not to exceed 30 ksi 	0.19√f'c (ksi)
Principal Tensile Stress at Neutral Axis in Web		
<ul style="list-style-type: none"> All types of segmental concrete bridges with internal and/or external tendons, unless the Owner imposes other criteria for critical structures. 	0.110√f'c (ksi)	

Estimate prestress force required

The required number of strands is usually governed by concrete tensile stresses at the bottom fiber for load combination at Service III at the section of maximum moment or at the harp points. For estimating the number of strands, only the stresses at midspans are considered.

Bottom tensile stresses at midspan due to applied dead and live loads using load combination Service III is:

$$f_b = \frac{M_g + M_s}{S_b} + \frac{M_{SDL} + (0.8)(M_{LT} + M_{LL})}{S_{bc}}$$

where

f_b = concrete stress at the bottom fiber of the beam

M_g = Unfactored bending moment due to beam self-weight

M_s = Unfactored bending moment due to slab weight

M_{SDL} = Unfactored bending moment due to super imposed dead load

M_{LT} = Bending moment due to truck load plus impact

M_{LL} = Bending moment due to lane load

Substituting the bending moments and section modulus values, bottom fiber stresses at mid span is:

$$f_{bc} = \frac{(1209.98 + 1179.03)(12)}{10521.33} + \frac{(347.81)(12) + (0.8)(1423.00 + 602.72)(12)}{16876.83}$$
$$= 2.725 + 1.400 = 4.125 \text{ ksi}$$

At service load conditions, allowable tensile stress is

$$F_b = 0.19\sqrt{f'_c}$$

[LRFD Art. 5.9.4.2b]

where f'_c = beam concrete strength at service, ksi

$$F_b = 0.19\sqrt{5} = -0.425 \text{ ksi}$$

Required precompressive stress in the bottom fiber after losses:

Bottom tensile stress – allowable tensile stress at final = $f_b - F_b$

$$f_{pb} = 4.125 - 0.425 = 3.700 \text{ ksi}$$

Assuming the distance from the center of gravity of strands to the bottom fiber of the beam is equal to $y_{bs} = 2 \text{ in.}$

Strand Eccentricity at midspan:

$$e_c = y_b - y_{bs} = 24.75 - 2 = 22.75 \text{ in.}$$

Bottom fiber stress due to prestress after losses:

$$f_b = \frac{P_{pe}}{A} + \frac{P_{pe} e_c}{S_b}$$

where P_{pe} = effective prestressing force after all losses

$$3.700 = \frac{P_{pe}}{788.4} + \frac{22.75 P_{pe}}{10521.33}$$

Solving for P_{pe} we get,

$$P_{pe} = 1078.5 \text{ Kips}$$

Assuming final losses = 20% of f_{pi}

Assumed final losses = $0.2(202.5) = 40.5$ ksi

$$202.5 = 0.75 * 270$$
$$0.75 f_{pu}$$

The prestress force per strand after losses

= (cross sectional area of one strand) [f_{pi} – losses]

= $0.153(202.5 - 40.5) = 24.78$ Kips

Number of Strands Required = $1078.5/24.78 = 43.52$

Try 44 – ½ in. diameter, 270 ksi strands as an initial trial

Post tension

Initial prestress = $0.9 f_{py}$

Assume Loss = 20%

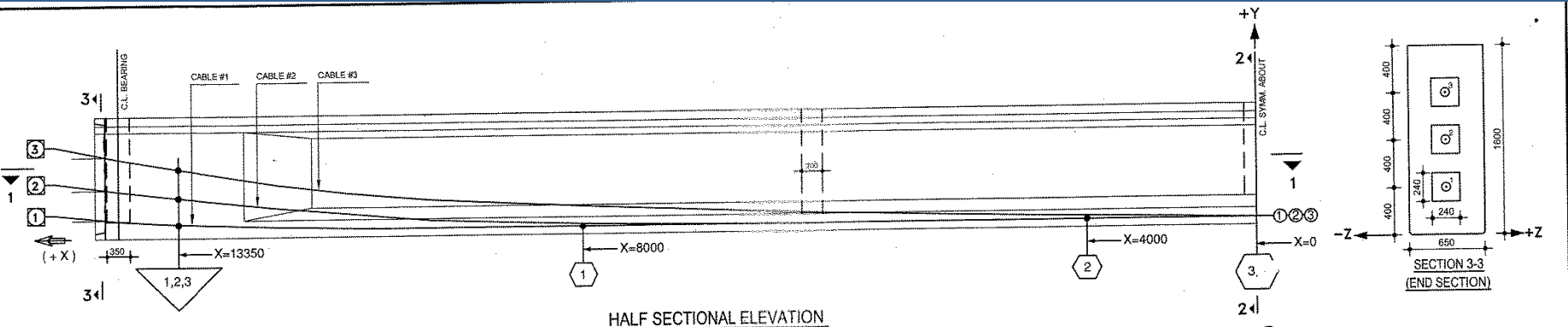

HALF SECTIONAL ELEVATION

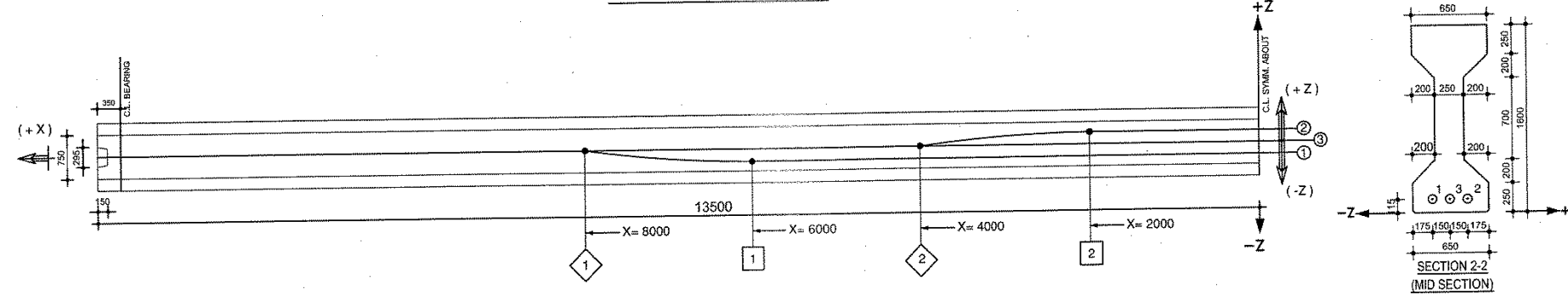

HALF SECTIONAL PLAN (SECTION 1-1)

TABLE

CABLE NO.	ORDINATES AT DISTANCE X FROM CENTRE																								ELONGATION AT EACH JACKING END (mm)	EMERGENCE ANGLE (°) AT END (Deg.)								
	13350		13000		12450		12000		11000		10000		9000		8000		7000		6000		5000		4000				3000		2000		1000		0	
	Y	Z	Y	Z	Y	Z	Y	Z	Y	Z	Y	Z	Y	Z	Y	Z	Y	Z	Y	Z	Y	Z	Y	Z			Y	Z	Y	Z	Y	Z		
1	400	0	371	0	318	0	279	0	207	0	156	0	115	0	115	0	115	-75	115	-150	115	-150	115	-150	115	-150	115	-150	115	-150	174	5.21		
2	800	0	756	0	680	0	621	0	503	0	400	0	313	0	242	0	186	0	147	0	123	0	115	0	115	75	115	150	115	150	115	150	172	7.61
3	1200	0	1149	0	1063	0	996	0	855	0	727	0	610	0	506	0	415	0	335	0	268	0	213	0	170	0	139	0	121	0	115	0	184	8.66

VERTICAL & HORIZONTAL PROFILE OF CABLES

LEGEND:

- INDICATES START OF CURVE IN ELEVATION
- INDICATES END OF CURVE IN ELEVATION
- INDICATES START OF CURVE IN PLAN
- INDICATES END OF CURVE IN PLAN
- INDICATES END OF CABLE
- INDICATES CABLE NUMBER

③
=0

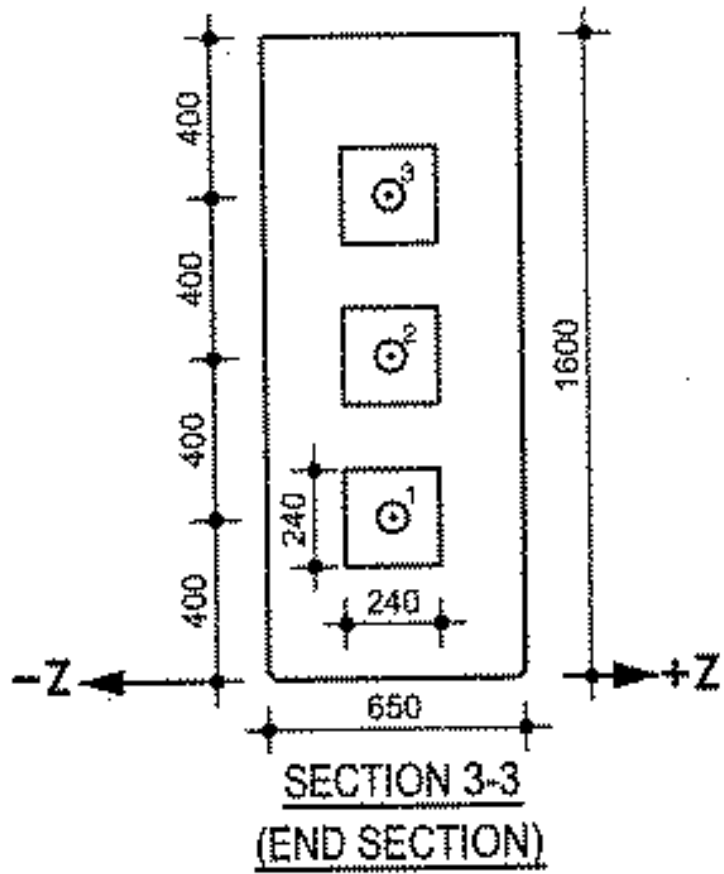

Z)
②
① ③

Z)

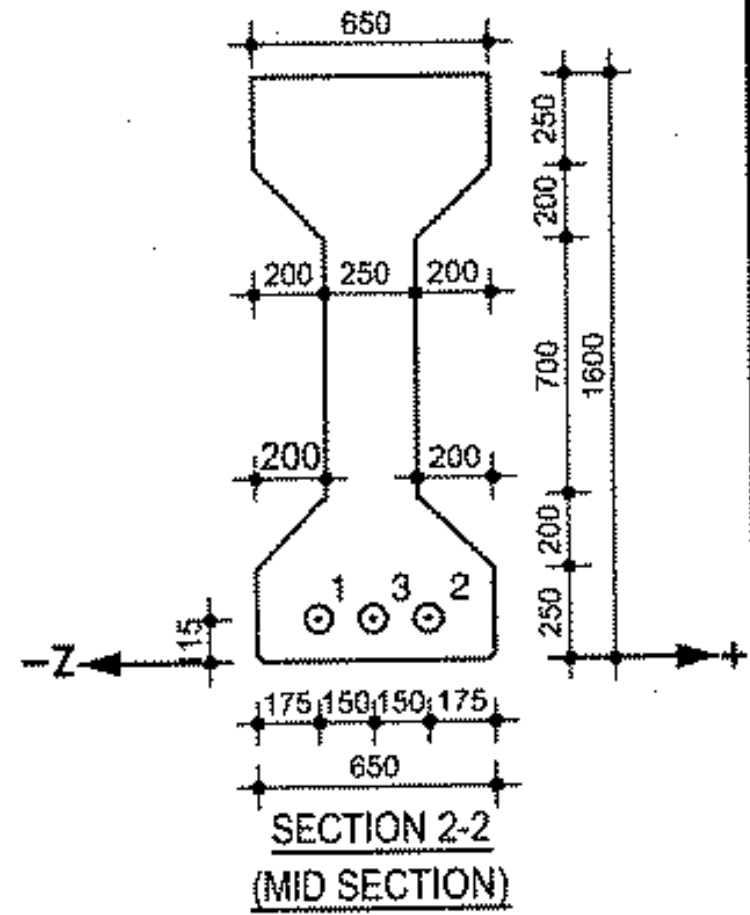

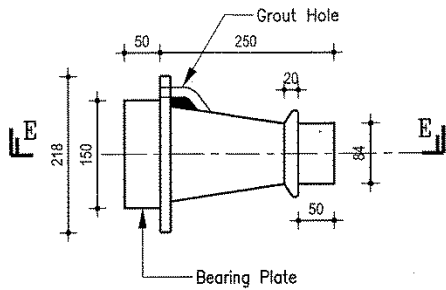

Freyssinet Branded 12T13 Anchorage

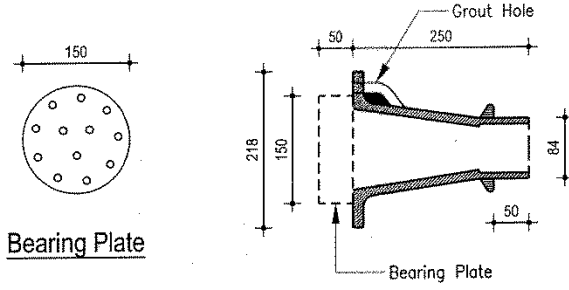

Bearing Plate

Section E-E

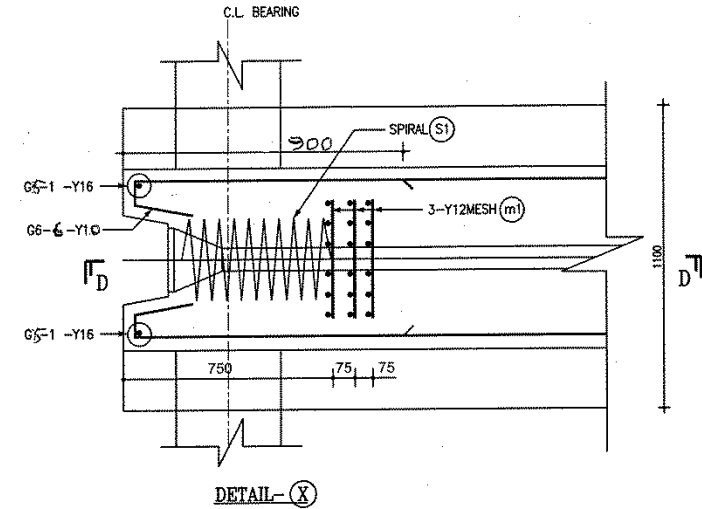

DETAIL-X

NOTES:

- ANCHORAGE MUST BE TESTED TO CONFIRM ITS CAPACITY APPLYING 95% OF ULTIMATE LOAD (2205 KN) AS PER STANDARD SPECIFICATION PRIOR TO USE
- HYDRAULIC LACKS FOR TENSIONING OPERATION MUST BE OF SAME BRANDED OF ANCHORAGE SYSTEM HAVING RECENT CALIBRATION
- TENSIONING OPERATION SHALL BE CARRIED OUT IN PRESENCE OF AN EXPERIENCED ENGINEER OR AS DIRECTED BY THE DESIGN UNIT, LGED
- THE PRE-STRESSING PARTY, IF SUBCONTRACTED, SHALL BE SELECTED TAKING PRIOR APPROVAL OF CONCERNED EXECUTIVE ENGINEER OR AS APPROVED BY DESIGN UNIT, LGED

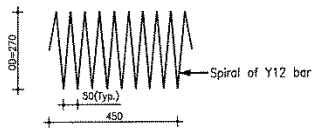

DETAILS OF SPIRAL S1

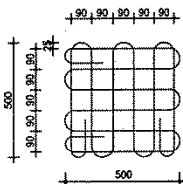
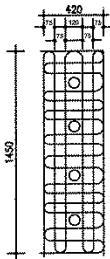

Y8 MESH REINF. ABOVE BEARINGS

Y12 MESH REINFORCEMENT (m1)

NOTES:

- ALL DIMENSIONS ARE IN mm UNLESS OTHERWISE MENTIONED
- VERTICAL SPACING OF MESH REINF. MAY BE ADJUSTED TO AVOID CLASHING WITH CABLES
- BENDING SCHEDULE OF SPIRAL AND MESH REINF. SHALL BE PREPARED AT SITE BEFORE FABRICATION & GET IT APPROVED.
- CONCRETE SHALL HAVE SPECIFIED CHARACTERISTIC COMPRESSIVE STRENGTH OF STANDARD CYLINDER OR CUBE (15 cm) AT 28 DAYS, ARE AS FOLLOWS
a) STANDARD CYLINDER CRUSHING STRENGTH, $f_c = 35 \text{ N/mm}^2$
b) STANDARD CUBE CRUSHING STRENGTH, $f_{cu} = 43 \text{ N/mm}^2$
- REINFORCING STEEL SHALL CONFORM TO ASTM A615-87 GRADE 40 DEFORMED BARS (MARKED 'Y') HAVING MINIMUM YIELD STRENGTH $F_y = 276 \text{ N/mm}^2$
- PRESTRESSING STEEL SHALL BE OF 12.7mm DIA. 7 PLY UNCOATED LOW RELAXATION STRAND CONFORMING TO AASHTO-M203 (GRADE-270) OR EQUIVALENT HAVING THE FOLLOWING STRENGTH:
(a) MINIMUM ULTIMATE TENSILE STRENGTH (UTS) $f'_s = 1861 \text{ N/mm}^2$ (183.7 KN PER STRAND)
(b) MINIMUM YIELD STRENGTH $f'_y = 1674 \text{ N/mm}^2$ (163.3 KN PER STRAND)
- CABLE SHALL BE CONSISTS OF 12 NOS. 12.7mm DIA STRAND (12T13) IN A SHEATHING/DUCT
- FOLLOWING PROPERTIES HAVE BEEN CONSIDERED IN THE DESIGN
AREA OF STRAND = 98.7 mm^2
AREA OF CABLE = 1184.4 mm^2
MODULES OF ELASTICITY OF STRAND = $1.95 \times 10^5 \text{ (N/mm}^2)$
AVERAGE SLP = 6mm
JACKING FORCE IN EACH CABLE = 1680 KN.

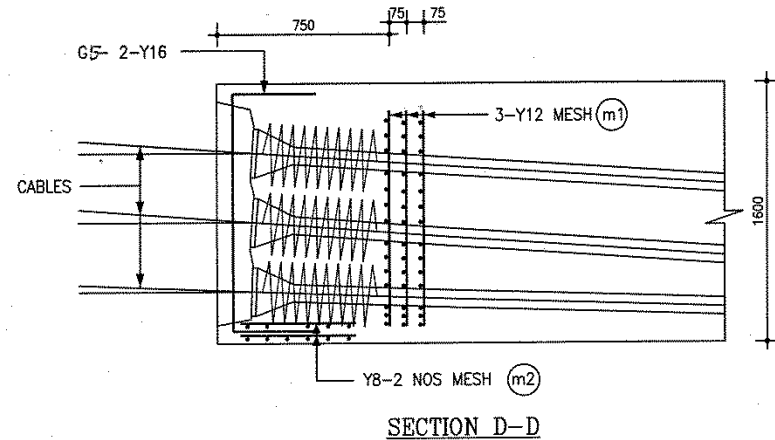

SECTION D-D

REVISION			
REV. NO.	DATE	DESCRIPTION	BY:

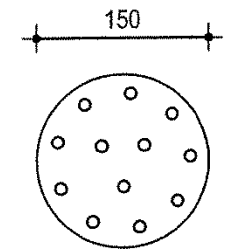
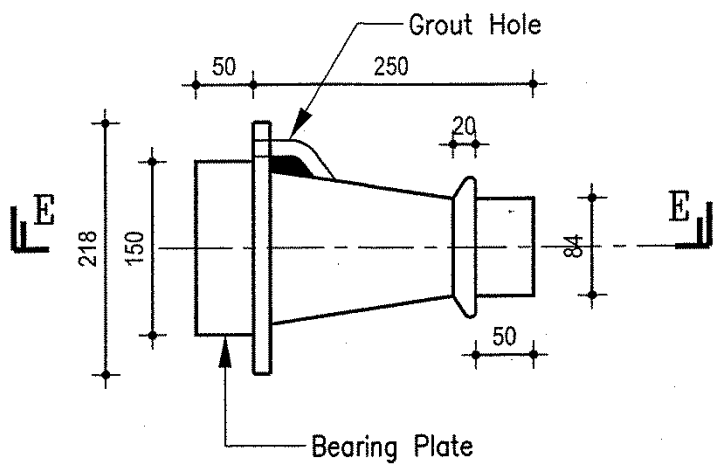

Bearing Plate

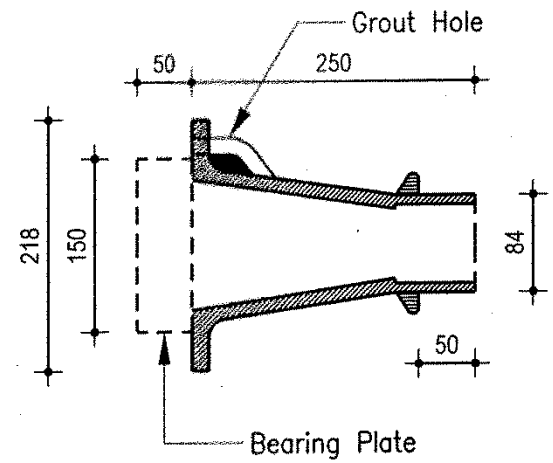

Section E-E

Freyssinet Branded 12T13 Anchorage

Check at transfer of prestress to girder

- At transfer, there is tension at top of girder and compression at bottom
- Check both these stresses are below allowable
- Only girder self wt
- Initial prestress
- Non composite section properties (only girder)

Flexural stress at transfer

Stress limits at transfer

Compression stress:

The allowable compression stress limit for pretensioned concrete components is calculated according to S5.9.4.1.1.

$$\begin{aligned} f_{\text{Compression}} &= -0.60(f'_{\text{ci}}) && \text{Initial concrete strength at the time of prestress} \\ &= -0.60(4.8 \text{ ksi}) \\ &= -2.88 \text{ ksi} \end{aligned}$$

Tension stress:

From Table S5.9.4.1.2-1, the stress limit in areas with bonded reinforcement sufficient to resist 120% of the tension force in the cracked concrete computed on the basis of an uncracked section is calculated as:

$$\begin{aligned} f_{\text{Tension}} &= 0.22\sqrt{f'_{\text{ci}}} && \text{Initial concrete strength at the time of prestress} \\ &= 0.22\sqrt{4.8} \\ &= 0.48 \text{ ksi} \end{aligned}$$

Stress calculations at transfer

Table 5.6-1 – Stresses at Top and Bottom of Beam at Transfer

Location (ft.) ⁽¹⁾	Girder self weight moment (k-ft) ⁽²⁾	F _{ps} at transfer (kips) ⁽³⁾	Stress at transfer	
			Top of beam (ksi)	Bottom of beam (ksi)
0	47	277.3	0.135	-0.654
1.75	153	924.4	0.451	-2.183
5.5	368	924.4	0.326	-2.055
11.0	656	993.7	0.209	-2.065
16.5	909	1,097.7	0.123	-2.171
22.0	1,128	1,097.7	-0.005	-2.040
27.5	1,313	1,271.0	-0.009	-2.358
33.0	1,464	1,271.0	-0.097	-2.269
38.5	1,580	1,271.0	-0.155	-2.209
44.0	1,663	1,271.0	-0.203	-2.160
49.5	1,711	1,271.0	-0.231	-2.132
54.5	1,725	1,271.0	-0.240	-2.120
55.0	1,725	1,271.0	-0.240	-2.123
60.5	1,705	1,271.0	-0.228	-2.135
66.0	1,650	1,271.0	-0.196	-2.168
71.5	1,562	1,271.0	-0.144	-2.220
77.0	1,439	1,271.0	-0.083	-2.284
82.5	1,282	1,271.0	0.009	-2.377
88.0	1,091	1,097.7	0.017	-2.063
93.5	865	1,097.7	0.149	-2.197
99.0	606	924.4	0.197	-1.923
104.5	312	924.4	0.358	-2.105
107.25	153	924.4	0.451	-2.200
109.0	47	277.3	0.135	-0.660

Definitions:

P_t = Initial prestressing force taken from Table 5.5-1 (kips)

A_g = Gross area of the basic beam (in^2)

e = Distance between the neutral axis of the noncomposite girder and the center of gravity of the prestressing steel (in.)

S_t = Section moduli, top of noncomposite beam (in^3)

S_b = Section moduli, bottom of noncomposite beam (in^3)

M_g = Moment due to the girder self weight only (k-ft)

Sample Calculations at 54 ft. – 6 in. From the CL of Bearing (55 ft. – 3 in. From Girder End) – Midspan of Noncomposite Beam

Girder top stress:

$$\begin{aligned}f_{\text{top}} &= -P_t/A_g + P_t e_{54.5}/S_t - M_g/S_t \\&= \frac{-1,271.0}{1,085} + \frac{1,271.0(31.38)}{20,588} - \frac{1,725(12)}{20,588} \\&= -0.239 \text{ ksi} < \text{Stress limit for compression (-2.88 ksi)} \quad \mathbf{OK}\end{aligned}$$

Girder bottom stress:

$$\begin{aligned}f_{\text{bottom}} &= -P_t/A_g - P_t e_{54.5}/S_b + M_g/S_b \\&= \frac{-1,271.0}{1,085} - \frac{1,271.0(31.38)}{20,157} + \frac{1,725(12)}{20,157} \\&= -2.123 \text{ ksi} < \text{Stress limit for compression (-2.88 ksi)} \quad \mathbf{OK}\end{aligned}$$

At final condition

- Compression at girder top and slab top
- Tension at girder bottom
- Check these stress levels against allowable

Final flexural stresses

Final flexural stress under Service I limit state

Maximum compression is checked under Service I limit state and maximum tension is checked under Service III limit state. The difference between Service I and Service III limit states is that Service I has a load factor of 1.0 for live load while Service III has a load factor of 0.8.

Stress limits

Compression stress:

From Table S5.9.4.2.1-1, the stress limit due to the sum of the effective prestress, permanent loads, and transient loads and during shipping and handling is taken as $0.6\phi_w f_c$ (where ϕ_w is equal to 1.0 for solid sections).

For prestressed concrete beams ($f_c = 6.0$ ksi)

$$\begin{aligned} f_{\text{Comp, beam1}} &= -0.6(6.0 \text{ ksi}) \\ &= -3.6 \text{ ksi} \end{aligned}$$

For deck slab ($f_c = 4.0$ ksi)

$$\begin{aligned} f_{\text{Comp, slab}} &= -0.6(4.0 \text{ ksi}) \\ &= -2.4 \text{ ksi} \end{aligned}$$

Girder compression check 1
Compression allowable stress
under all load +prestress

Slab compression check
Compression allowable stress
under Super DL+LL

From Table S5.9.4.2.1-1, the stress limit in prestressed concrete at the service limit state after losses for fully prestressed components in bridges other than segmentally constructed due to the sum of effective prestress and permanent loads shall be taken as:

$$\begin{aligned} f_{\text{Comp, beam 2}} &= -0.45(f_c) \\ &= -0.45(6.0) \\ &= -2.7 \text{ ksi} \end{aligned}$$

Girder compression check 2
Compression allowable stress
under all Dead Load +prestress

From Table S5.9.4.2.1-1, the stress limit in prestressed concrete at the service limit state after losses for fully prestressed components in bridges other than segmentally constructed due to live load plus one-half the sum of the effective prestress and permanent loads shall be taken as:

$$\begin{aligned} f_{\text{Comp, beam 3}} &= -0.40(f'_c) \\ &= -0.40(6.0) \\ &= -2.4 \text{ ksi} \end{aligned}$$

Girder compression check 3
Compression allowable stress
under LL+ ½(Dead Load
+prestress)

Tension stress:

From Table S5.9.4.2.2-1, the stress limit in prestressed concrete at the service limit state after losses for fully prestressed components in bridges other than segmentally constructed, which include bonded prestressing tendons and are subjected to not worse than moderate corrosion conditions shall be taken as the following:

$$\begin{aligned} f_{\text{Tensile}} &= 0.19\sqrt{f'_c} \\ &= 0.19\sqrt{6} \\ &= 0.465 \text{ ksi} \end{aligned}$$

Table 5.6-2 – Stresses in the Prestressed Beam

Location	Girder noncomposite moment	F_{ps} after losses	Composite dead load moment	Live load positive moment
(ft.) ⁽¹⁾	(k-ft) ⁽²⁾	(kips) ⁽³⁾	(k-ft) ⁽²⁾	(k-ft) ⁽²⁾
0	0	239.0	0	0
1.75	217	797.2	36	170
5.5	661	797.0	108	476
11.0	1,252	857.0	199	886
16.5	1,776	946.7	276	1,230
22.0	2,230	946.7	337	1,509
27.5	2,616	1,092.1	384	1,724
33.0	2,933	1,092.1	414	1,882
38.5	3,181	1,096.2	429	1,994
44.0	3,360	1,096.2	429	2,047
49.5	3,471	1,096.2	414	2,045
54.5	3,512	1,096.2	387	2,015
55.0	3,511	1,096.2	384	2,010
60.5	3,456	1,096.2	338	1,927
66.0	3,333	1,096.2	277	1,794
71.5	3,141	1,096.2	201	1,613
77.0	2,880	1,096.2	108	1,388
82.5	2,551	1,096.2	2	1,124
88.0	2,152	946.7	-121	825
93.5	1,686	946.7	-258	524
99.0	1,150	797.2	-452	297
104.5	546	797.2	-580	113
107.25	217	797.2	-670	58
109.0	0	239.0	-729	15

Table 5.6-2 – Stresses in the Prestressed Beam (cont.)

Location	Final stress under PS & DL		Stress under 1/2 (DL + P/S) + live load	Final stress under all loads		
	Top of beam	Bottom of beam		Top of beam	Bottom of beam	Top of slab
(ft.) ⁽¹⁾	(ksi) ⁽⁴⁾	(ksi) ⁽⁴⁾	(ksi) ⁽⁴⁾	(ksi) ⁽⁴⁾	(ksi) ⁽⁵⁾	(ksi) ⁽⁴⁾
0	0.140	-0.588	0.070	0.140	-0.588	0.000
1.75	0.333	-1.816	0.136	0.303	-1.755	-0.041
5.5	0.061	-1.519	-0.054	-0.023	-1.349	-0.116
11.0	-0.255	-1.283	-0.285	-0.412	-0.966	-0.215
16.5	-0.521	-1.158	-0.479	-0.739	-0.719	-0.298
22.0	-0.796	-0.861	-0.666	-1.064	-0.321	-0.365
27.5	-0.943	-0.969	-0.777	-1.249	-0.353	-0.417
33.0	-1.133	-0.767	-0.900	-1.467	-0.094	-0.454
38.5	-1.270	-0.631	-0.988	-1.623	0.081	-0.479
44.0	-1.374	-0.525	-1.050	-1.737	0.207	-0.490
49.5	-1.436	-0.465	-1.081	-1.799	0.266	-0.487
54.5	-1.455	-0.453	-1.085	-1.812	0.267	-0.475
55.0	-1.454	-0.455	-1.083	-1.810	0.263	-0.474
60.5	-1.414	-0.508	-1.049	-1.756	0.180	-0.448
66.0	-1.331	-0.609	-0.984	-1.649	0.032	-0.410
71.5	-1.206	-0.757	-0.889	-1.492	-0.181	-0.359
77.0	-1.046	-0.945	-0.769	-1.292	-0.449	-0.296
82.5	-0.835	-1.189	-0.617	-1.034	-0.787	-0.223
88.0	-0.670	-1.112	-0.481	-0.816	-0.817	-0.139
93.5	-0.374	-1.450	-0.280	-0.467	-1.263	-0.053
99.0	-0.116	-1.487	-0.111	-0.169	-1.381	0.031
104.5	0.250	-1.910	0.105	0.230	-1.870	0.092
107.25	0.458	-2.146	0.219	0.448	-2.125	0.121
109.0	0.269	-0.918	0.132	0.266	-0.913	0.141

Definitions:

- P_t = Final prestressing force taken from Design Step 5.4 (kips)
- S_{tc} = Section moduli, top of the beam of the composite section – gross section (in^3)
- S_{bc} = Section moduli, bottom of the beam of the composite section – gross section (in^3)
- S_{tsc} = Section moduli, top of slab of the composite beam (in^3)

- M_{DNC} = Moment due to the girder, slab, haunch and interior diaphragm (k-ft)
- M_{DC} = Total composite dead load moment, includes parapets and future wearing surface (k-ft)
- M_{LLC} = Live load moment (k-ft)

Sample Calculations at 54 ft. – 6 in. From the CL of Bearing (55 ft. – 3 in. From Girder End) – Midspan of Noncomposite Girder

Girder top stress after losses under sum of all loads (Service I):

$$\begin{aligned} f_{\text{top}} &= -P_t/A_g + P_t e_{54.5}/S_t - M_{\text{DNC}}/S_t - M_{\text{DC}}/S_{\text{tc}} - M_{\text{LLC}}/S_{\text{tc}} \\ &= \frac{-1,096.2}{1,085} + \frac{1,096.2(31.38)}{20,588} - \frac{3,512(12)}{20,588} - \frac{387(12)}{67,672} - \frac{2,015(12)}{67,672} \\ &= -1.010 + 1.671 - 2.047 - 0.069 - 0.357 \end{aligned}$$

$$= -1.812 \text{ ksi} < \text{Stress limit for compression under full load } (-3.6 \text{ ksi}) \text{ OK}$$

Girder compression check 1
Compression allowable stress under all load +prestress

Girder top stress after losses under prestress and permanent loads:

$$\begin{aligned} f_{\text{top}} &= -P_t/A_g + P_t e_{54.5} / S_t - M_{\text{DNC}} / S_t - M_{\text{DC}} / S_{tc} \\ &= \frac{-1,096.2}{1,085} + \frac{1,096.2(31.38)}{20,588} - \frac{3,512(12)}{20,588} - \frac{387(12)}{67,672} \\ &= -1.010 + 1.671 - 2.047 - 0.069 \\ &= -1.455 \text{ ksi} < \text{Stress limit for compression under prestress and permanent loads } (-2.7 \text{ ksi}) \text{ OK} \end{aligned}$$

Girder compression check 2
Compression allowable stress under all Dead Load +prestress

Girder top stress under LL + 1/2(PS + DL) after losses:

$$\begin{aligned} f_{\text{top}} &= -P_t/A_g + P_t e_{54.5}/S_t - M_{\text{DNC}}/S_t - M_{\text{DC}}/S_{\text{tc}} - M_{\text{LL}}/S_{\text{tc}} \\ &= \frac{-1,096.2}{1,085(2)} + \frac{1,096.2(31.38)}{20,588(2)} - \frac{3,512(12)}{20,588(2)} - \frac{387(12)}{67,672(2)} - \frac{2,015(12)}{67,672} \\ &= -0.505 + 0.835 - 1.024 - 0.034 - 0.357 \\ &= -1.085 \text{ ksi} < \text{Stress limit for compression under LL + 1/2(DL + PS)} \\ &\quad \text{load (-2.4 ksi) } \mathbf{OK} \end{aligned}$$

Girder compression check 3
Compression allowable stress
under LL+ 1/2(Dead Load
+prestress)

Girder bottom stress (Service III):

$$\begin{aligned}f_{\text{bottom}} &= -P_t/A_g - P_t e_{54.5}/S_b + M_{\text{DNC}}/S_b + M_{\text{DC}}/S_{bc} + M_{\text{LLC}}/S_{bc} \\&= \frac{-1,096.2}{1,085} - \frac{1,096.2(31.38)}{20,157} + \frac{3,512(12)}{20,157} + \frac{387(12)}{26,855} + \frac{0.8(2,015)(12)}{26,855} \\&= -1.010 - 1.707 + 2.091 + 0.173 + 0.720 \\&= 0.267 \text{ ksi} < \text{Stress limit for tension (0.465 ksi) } \mathbf{OK}\end{aligned}$$

Note 0.8

Girder bottom stress after losses under prestress and dead load:

$$\begin{aligned}f_{\text{bottom}} &= -P_t/A_g - P_t e_{54.5}/S_b + M_{\text{DNC}}/S_b + M_{\text{DC}}/S_{bc} \\&= \frac{-1,096.2}{1,085} - \frac{1,096.2(31.38)}{20,157} + \frac{3,512(12)}{20,157} + \frac{387(12)}{26,855} \\&= -1.010 - 1.707 + 2.091 + 0.173 \\&= -0.453 \text{ ksi} < \text{Stress limit for compression (-2.7 ksi) } \mathbf{OK}\end{aligned}$$

Checking if there is compression without LL and check against allowable

Deck slab top stress under full load:

$$\begin{aligned}f_{\text{top slab}} &= (-M_{\text{DC}}/S_{\text{tsc}} - M_{\text{LLC}}/S_{\text{tsc}})/\text{modular ratio between beam and slab} \\&= \left(-\frac{387(12)}{49,517} - \frac{1.0(2,015)(12)}{49,517} \right) / \left(\frac{4,696}{3,834} \right) \\&= (-0.094 - 0.488)/1.225 \\&= -0.475 \text{ ksi} < \text{Stress limit for compression in slab (-2.4 ksi) } \mathbf{OK}\end{aligned}$$

Longitudinal steel top of girder

Longitudinal steel at top of girder

The tensile stress limit at transfer used in this example requires the use of steel at the tension side of the beam to resist at least 120% of the tensile stress in the concrete calculated based on an uncracked section (Table S5.9.4.1.2-1). The sample calculations are shown for the section in Table 5.6-1 with the highest tensile stress at transfer, i.e., the section at 1.75 ft. from the centerline of the end bearing.

By integrating the tensile stress in Figure 5.6-2 over the corresponding area of the beam, the tensile force may be calculated as:

$$\begin{aligned}\text{Tensile force} &= 5(42)(0.451 + 0.268)/2 + 7.33(8.0)(0.268 + 0.0)/2 + 2[4(3)](0.268 + \\ & 0.158)/2 + 2[4(4)/2][0.012 + (0.158 - 0.012)(2/3)] + 2[3(13)/2][0.158 + \\ & (0.268 - 0.158)(2/3)] \\ &= 99.2 \text{ k}\end{aligned}$$

$$\begin{aligned}\text{Required area of steel} &= 1.2(99.2)/f_y \\ &= 119.0/60 \\ &= 1.98 \text{ in}^2\end{aligned}$$

$$\begin{aligned}\text{Required number of \#5 bars} &= 1.98/0.31 \\ &= 6.39 \text{ bars}\end{aligned}$$

Minimum allowable number of bars = 7 #5 bars

Use 8 #5 bars as shown in Figure 5.6-3

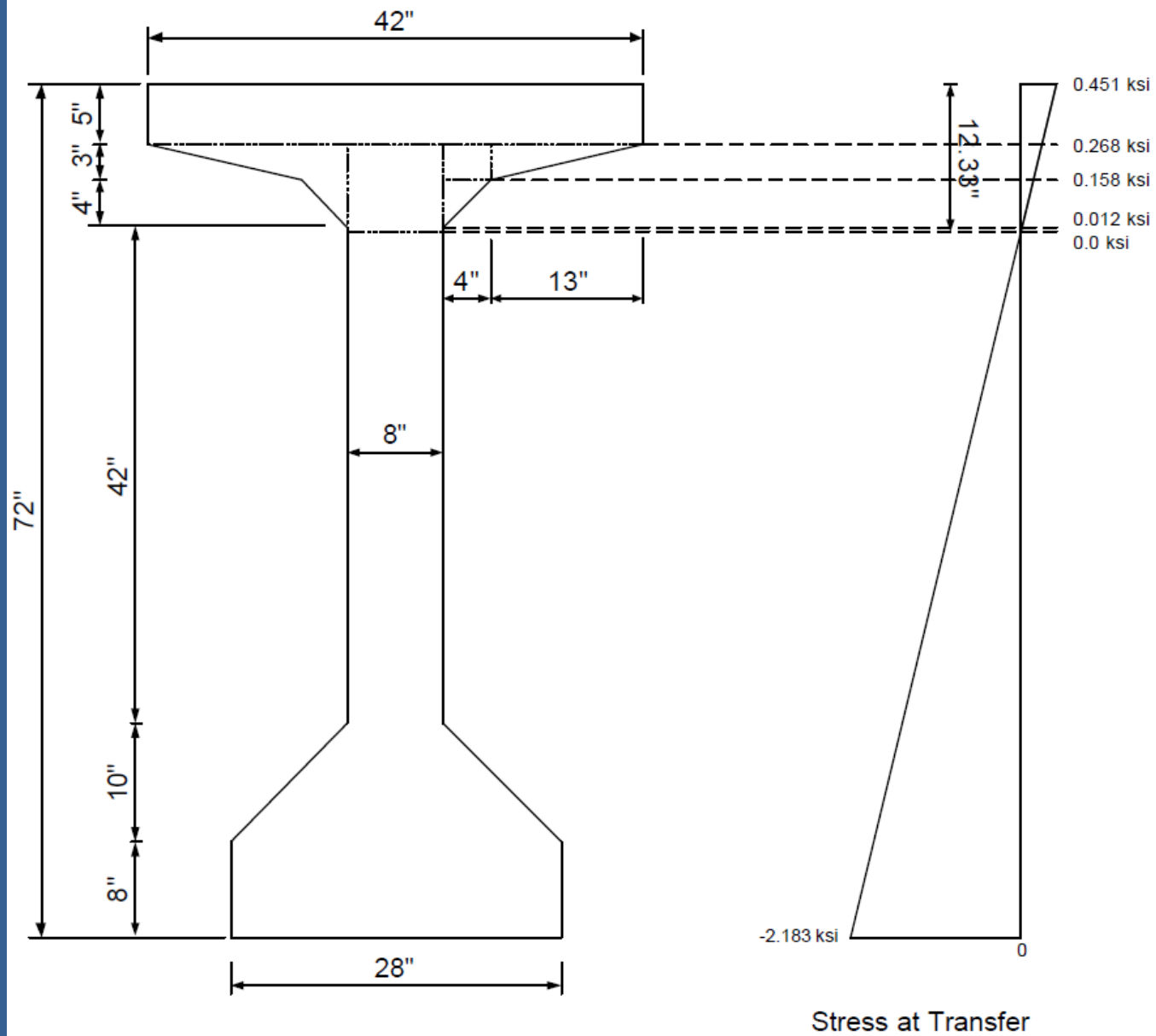

Figure 5.6-2 – Stress at Location of Maximum Tensile Stress at Transfer

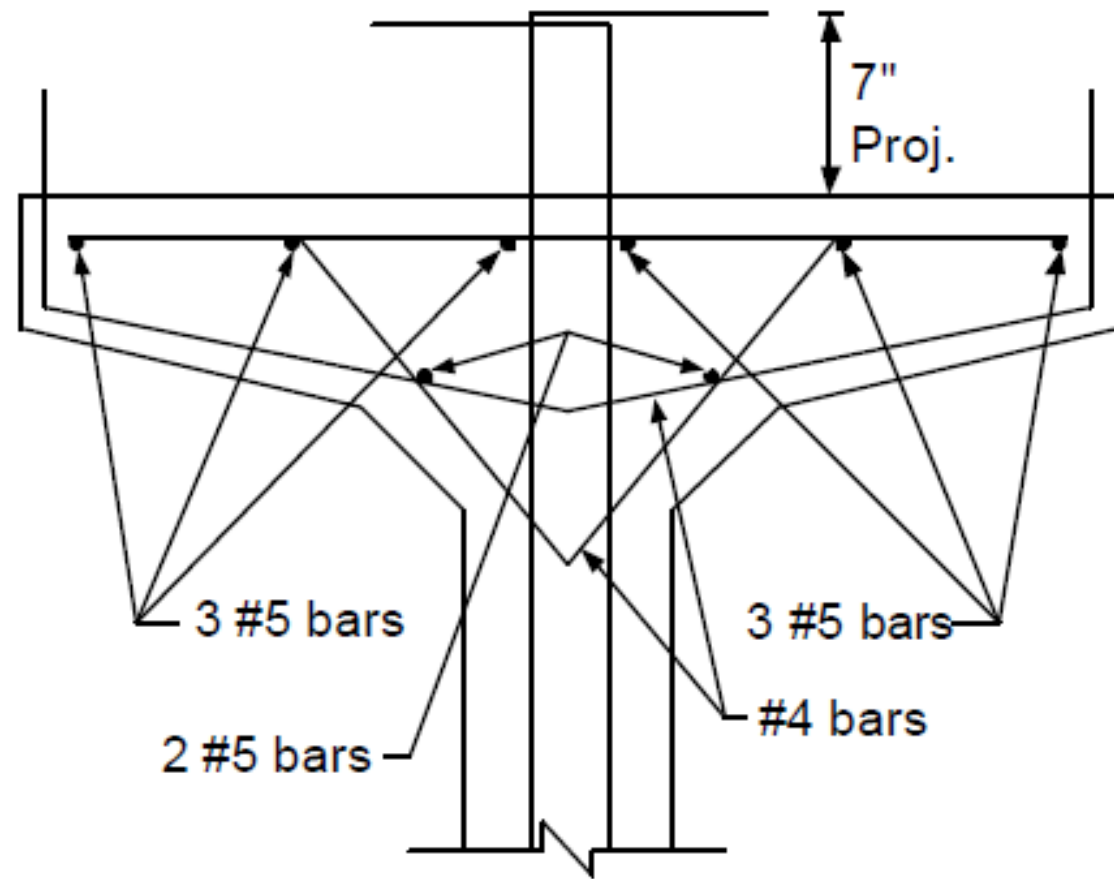

Figure 5.6-3 – Longitudinal Reinforcement of Girder Top Flange

Flexural resistance

Flexural resistance at the strength limit state in positive moment region (S5.7.3.1)

Sample calculations at midspan

c = distance between the neutral axis and the compressive face at the nominal flexural resistance (in.)

c = 5.55 in., which is less than the slab thickness, therefore, the neutral axis is in the slab and section is treated as a rectangular section. (See Design Step 5.5.1 for commentary explaining how to proceed if “ c ” is greater than the deck thickness.)

f_{ps} = stress in the prestressing steel at the nominal flexural resistance (ksi)

f_{ps} = 264.4 ksi

$$\begin{aligned}f_{ps} &= f_{pu}[1 - k(c/d_p)] \\ &= 270[1 - 0.28(5.55/74.5)] \\ &= 264.4 \text{ ksi}\end{aligned}$$

for rectangular section behavior (Eq. S5.7.3.1.1-4):

$$c = \frac{A_{ps} f_{pu} + A_s f_y - A'_s f'_y}{0.85 f'_c \beta_1 b + k A_{ps} \frac{f_{pu}}{d_p}}$$

T-sections where the neutral axis lies in the flange, i.e., “c” is less than the slab thickness, are considered rectangular sections.

From Table SC5.7.3.1.1-1:

$$k = 0.28 \text{ for low relaxation strands}$$

Assuming rectangular section behavior with no compression steel or mild tension reinforcement:

$$c = A_{ps} f_{pu} / [0.85 f'_c \beta_1 b + k A_{ps} (f_{pu} / d_p)]$$

For the midspan section

$$\begin{aligned}\text{Total section depth, } h &= \text{girder depth} + \text{structural slab thickness} \\ &= 72 + 7.5 \\ &= 79.5 \text{ in.}\end{aligned}$$

$$\begin{aligned}d_p &= h - (\text{distance from bottom of beam to location of P/S steel force}) \\ &= 79.5 - 5.0 \\ &= 74.5 \text{ in.}\end{aligned}$$

$$\beta_1 = 0.85 \text{ for 4 ksi slab concrete (S5.7.2.2)}$$

$$\begin{aligned}b &= \text{effective flange width (calculated in Section 2 of this example)} \\ &= 111 \text{ in.}\end{aligned}$$

$$\begin{aligned}c &= 6.73(270)/[0.85(4)(0.85)(111) + 0.28(6.73)(270/74.5)] \\ &= 5.55 \text{ in.} < \text{structural slab thickness} = 7.5 \text{ in.}\end{aligned}$$

The assumption of the section behaving as a rectangular section is correct.

The factored flexural resistance, M_f , shall be taken as ϕM_n , where M_n is determined using Eq. S5.7.3.2.2-1.

Factored flexural resistance in flanged sections (S5.7.3.2.2)

$$M_n = A_{ps}f_{ps}(d_p - a/2) + A_s f_y (d_s - a/2) - A'_s f'_y (d'_s - a/2) + 0.85f'_c(b - b_w)\beta_1 h_f(a/2 - h_f/2)$$

(S5.7.3.2.2-1)

The definition of the variables in the above equation and their values for this example are as follows:

$$A_{ps} = \text{area of prestressing steel (in}^2\text{)}$$
$$= 6.73 \text{ in}^2$$

$$f_{ps} = \text{average stress in prestressing steel at nominal bending resistance}$$
$$\text{specified in Eq. S5.7.3.1.1-1 (ksi)}$$
$$= 264.4 \text{ ksi}$$

d_p = distance from extreme compression fiber to the centroid of prestressing tendons (in.)
= 74.5 in.

A_s = area of nonprestressed tension reinforcement (in^2)
= 0.0 in^2

f_y = specified yield strength of reinforcing bars (ksi)
= 60 ksi

d_s = distance from extreme compression fiber to the centroid of nonprestressed tensile reinforcement (in.), NA

A'_s = area of compression reinforcement (in²)
= 0.0 in²

f_y = specified yield strength of compression reinforcement (ksi), NA

d'_s = distance from the extreme compression fiber to the centroid of compression reinforcement (in.), NA

f'_c = specified compressive strength of concrete at 28 days, unless another age is specified (ksi)
= 4.0 ksi (slab)

b = width of the effective compression block of the member (in.)
= width of the effective flange = 111 in. (See Design Step 5.5.1 for commentary for the determination of the effective width, b, when the calculations indicate that the compression block depth is larger than the flange thickness.)

b_w = web width taken equal to the section width “b” for a rectangular section (in.), NA

β_1 = stress block factor specified in S5.7.2.2, NA

h_f = compression flange depth of an I or T member (in.), NA

a = $\beta_1 c$; depth of the equivalent stress block (in.)
= 0.85(5.55)
= 4.72 in.

The second, third and fourth terms in Eq. S5.7.3.2.2-1 are equal to zero for this example.

Substituting,

$$\begin{aligned}M_n &= 6.73(264.4)[74.5 - (4.72/2)] \\ &= 128,367/12 \\ &= 10,697 \text{ k-ft}\end{aligned}$$

Therefore, the factored flexural resistance, M_r , shall be taken as:

$$M_r = \phi M_n \quad (\text{S5.7.3.2.1-1})$$

where:

$$\begin{aligned}\phi &= \text{resistance factor as specified in S5.5.4.2 for flexure in prestressed} \\ &\quad \text{concrete} \\ &= 1.0\end{aligned}$$

$$\begin{aligned}M_r &= 1.0(10,697 \text{ k-ft}) \\ &= 10,697 \text{ k-ft}\end{aligned}$$

The maximum factored applied moment for Strength I limit state is 8,456 k-ft (see Table 5.3-2)

$$M_r = 10,697 \text{ k-ft} > M_u = 8,456 \text{ k-ft} \quad \mathbf{OK}$$

Check if section is over-reinforced

Limits for reinforcing (S5.7.3.3)

The maximum amount of prestressed and nonprestressed reinforcement must be such that:

$$c/d_e \leq 0.42 \quad (\text{S5.7.3.3.1-1})$$

where:

$$c = 5.55 \text{ in. (see Section 5.5.1)}$$

$$d_e = 74.5 \text{ in. (same as } d_p \text{ since no mild steel is considered)}$$

$$\begin{aligned} c/d_e &= 5.55/74.5 \\ &= 0.074 < 0.42 \quad \mathbf{OK} \end{aligned}$$

Check minimum required reinforcement (S5.7.3.3.2)

Critical location is at the midspan of the continuous span = 55 ft. from the end bearing.

All strands are fully bonded at this location.

According to S5.7.3.3.2, unless otherwise specified, at any section of a flexural component, the amount of prestressed and nonprestressed tensile reinforcement shall be adequate to develop a factored flexural resistance, M_r , at least equal to the lesser of:

1.2 times the cracking strength determined on the basis of elastic stress distribution and the modulus of rupture, f_r , on the concrete as specified in S5.4.2.6.

OR

1.33 times the factored moment required by the applicable strength load combinations specified in Table 3.4.1-1.

The cracking moment, M_{cr} , is calculated as the total moment acting on the beam when the maximum tensile stress equals the modulus of rupture.

$$f_r = -P_t/A_g - P_t e/S_b + M_{DNC}/S_b + M_{DC}/S_{bc} + M/S_{bc}$$

where:

$$\begin{aligned} M_{DNC} &= \text{factored using Service I limit state, see Table 5.3-1} \\ &= 3,511 \text{ k-ft} \end{aligned}$$

$$\begin{aligned} M_{DC} &= \text{factored using Service I limit state, see Table 5.3-1} \\ &= 384 \text{ k-ft} \end{aligned}$$

$$\begin{aligned} P_t &= f_{pf} A_{strand} N_{strands} \\ &= 1,096.2 \text{ k (from Table 5.6-2)} \end{aligned}$$

$$\begin{aligned} A_g &= 1,085 \text{ in}^2 \\ e_{54.5'} &= 31.38 \text{ in.} \\ S_b &= 20,157 \text{ in}^3 \\ S_{bc} &= 26,855 \text{ in}^3 \end{aligned}$$

$$\begin{aligned} f_r &= 0.24 \sqrt{f'_c} && \text{(S5.4.2.6)} \\ &= 0.24 \sqrt{6} \\ &= 0.587 \text{ ksi} \end{aligned}$$

$$0.587 = \frac{-1,096.2}{1,085} - \frac{1,096.2(31.38)}{20,157} + \frac{3,511(12)}{20,157} + \frac{384(12)}{26,855} + \frac{M}{26,855}$$

Solving for M, the additional moment required to cause cracking, in this equation:

$$\begin{aligned} M &= 27,983/12 \\ &= 2,332 \text{ k-ft} \end{aligned}$$

$$\begin{aligned} M_{cr} &= M_{DNC} + M_{DC} + M \\ &= 3,511 + 384 + 2,332 \\ &= 6,227 \text{ k-ft} \end{aligned}$$

$$\begin{aligned} 1.2M_{cr} &= 1.2(6,227) \\ &= 7,472 \text{ k-ft} \end{aligned}$$

The applied factored moment, M_u , taken from Table 5.3-2 is 8,456 k-ft (Strength I)

$$1.33(8,456) = 11,246 \text{ k-ft}$$

M_r has to be greater than the lesser of $1.2M_{cr}$ and $1.33M_u$, i.e., 7,472 k-ft.

M_r also has to be greater than the applied factored load $M_u = 8,456$ k-ft (strength requirement)

$M_r = 10,697$ k-ft, therefore, both provisions are **OK**

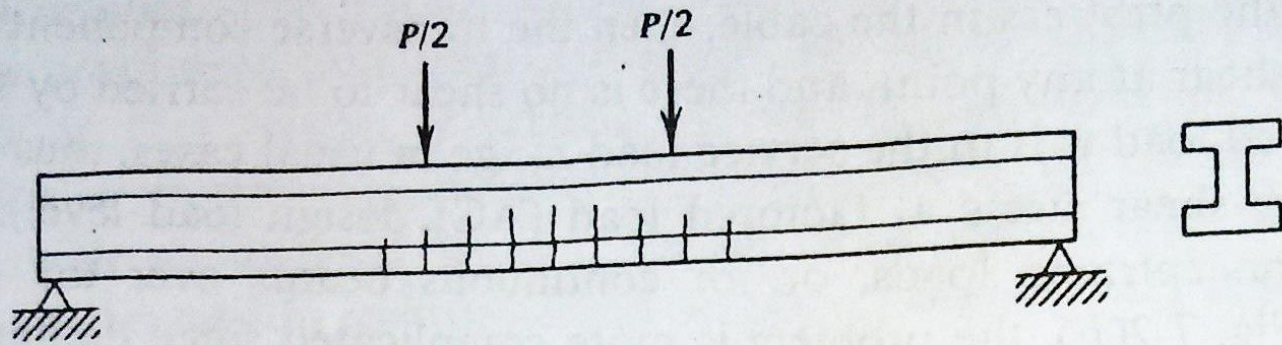

(a) Initial Flexural Cracking (P slightly more than service load for typical beam)

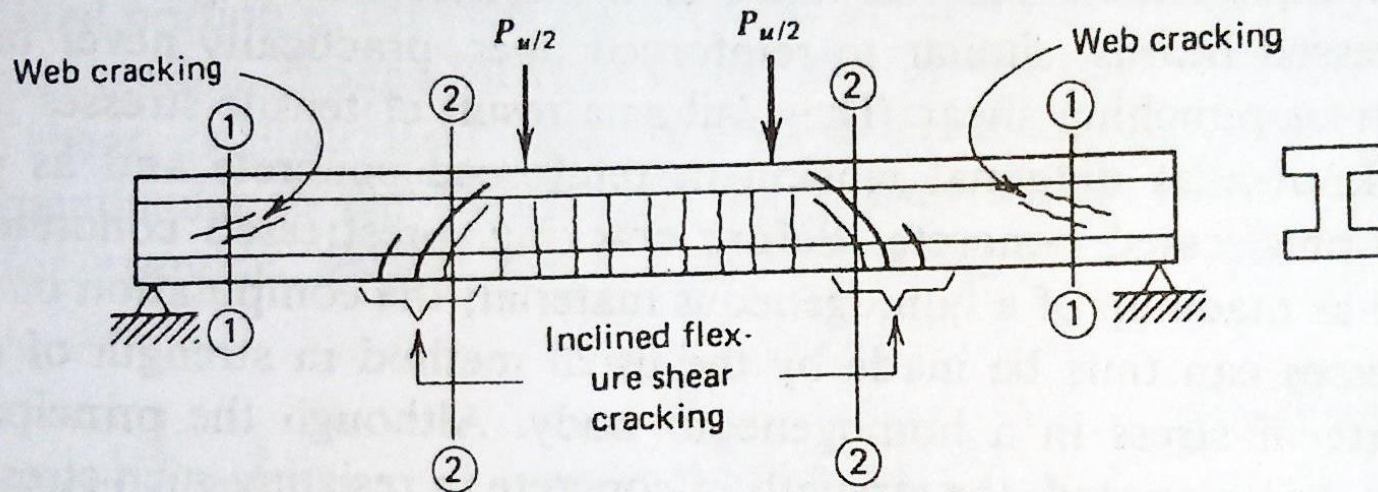

(b) Flexure-Shear Cracking at Factored Load

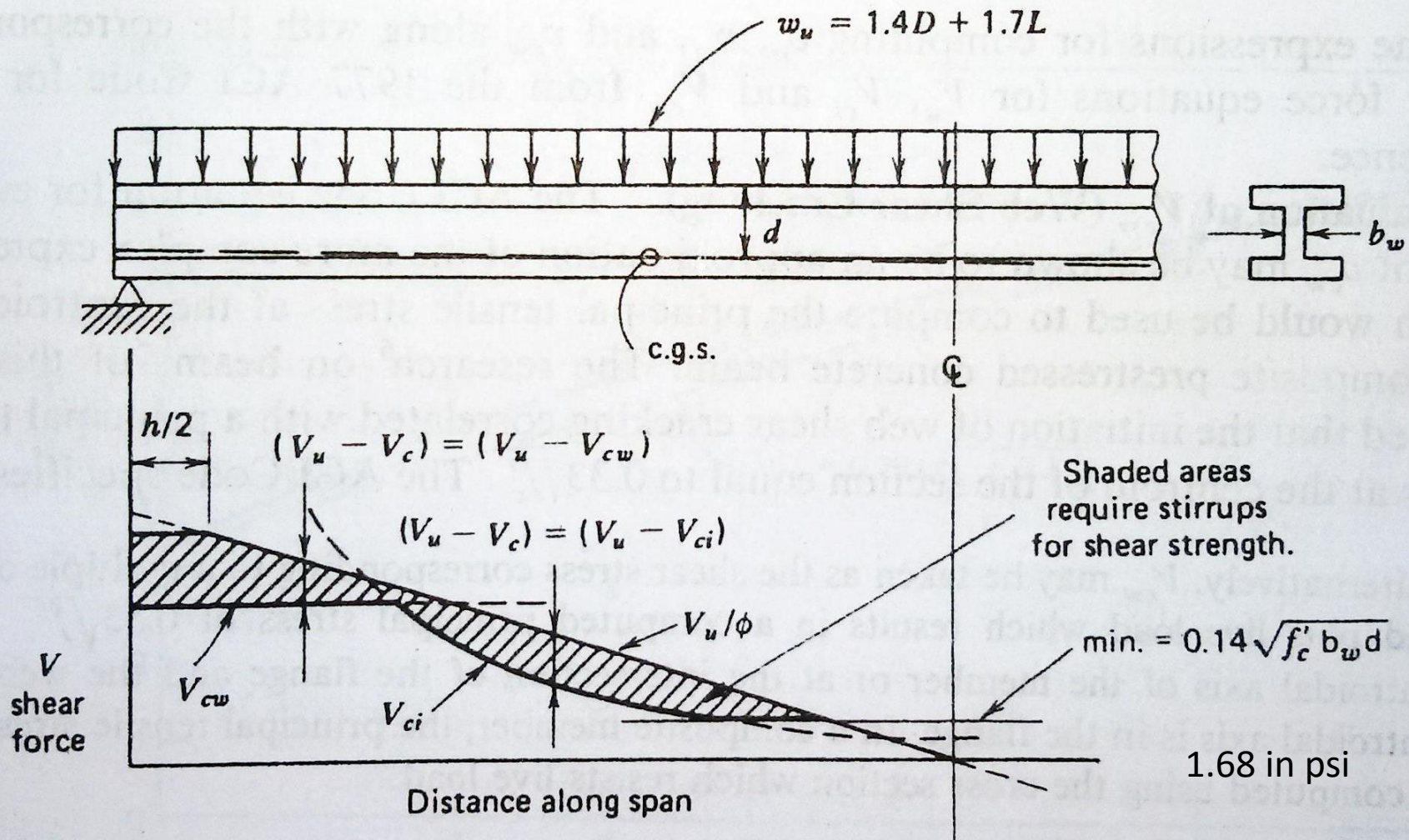

Shear design

The factored shear resistance, V_r , shall be taken as:

$$V_r = \phi V_n \quad (5.8.2.1-2)$$

V_n = nominal shear resistance specified in Article 5.8.3.3 (kip)

ϕ = resistance factor as specified in Article 5.5.4.2

5.8.2.4—Regions Requiring Transverse Reinforcement

Except for slabs, footings, and culverts, transverse reinforcement shall be provided where:

- $V_u > 0.5\phi(V_c + V_p)$ (5.8.2.4-1)

or

- Where consideration of torsion is required by Eq. 5.8.2.1-3 or Eq. 5.8.6.3-1

where:

V_u = factored shear force (kip)

V_c = nominal shear resistance of the concrete (kip)

V_p = component of prestressing force in direction of the shear force; $V_p = 0$ when the simplified method of 5.8.3.4.3 is used (kip)

ϕ = resistance factor specified in Article 5.5.4.2

5.8.2.5—Minimum Transverse Reinforcement

Except for segmental post-tensioned concrete box girder bridges, where transverse reinforcement is required, as specified in Article 5.8.2.4, the area of steel shall satisfy:

$$A_v \geq 0.0316 \sqrt{f'_c} \frac{b_v s}{f_y} \quad (5.8.2.5-1)$$

where:

A_v = area of a transverse reinforcement within distance s (in.²)

b_v = width of web adjusted for the presence of ducts as specified in Article 5.8.2.9 (in.)

s = spacing of transverse reinforcement (in.)

f_y = yield strength of transverse reinforcement (ksi)

5.8.2.7—Maximum Spacing of Transverse Reinforcement

The spacing of the transverse reinforcement shall not exceed the maximum permitted spacing, s_{max} , determined as:

- If $v_u < 0.125 f'_c$, then:

$$s_{max} = 0.8d_v \leq 24.0 \text{ in.} \quad (5.8.2.7-1)$$

- If $v_u \geq 0.125 f'_c$, then:

$$s_{max} = 0.4d_v \leq 12.0 \text{ in.} \quad (5.8.2.7-2)$$

where:

v_u = the shear stress calculated in accordance with Article 5.8.2.9 (ksi)

d_v = effective shear depth as defined in Article 5.8.2.9 (in.)

5.8.2.9—Shear Stress on Concrete

The shear stress on the concrete shall be determined as:

$$v_u = \frac{|V_u - \phi V_p|}{\phi b_v d_v} \quad (5.8.2.9-1)$$

where:

ϕ = resistance factor for shear specified in Article 5.5.4.2

b_v = effective web width taken as the minimum web width, measured parallel to the neutral axis, between the resultants of the tensile and compressive forces due to flexure, or for circular sections, the diameter of the section, modified for the presence of ducts where applicable (in.)

d_v = effective shear depth taken as the distance, measured perpendicular to the neutral axis, between the resultants of the tensile and compressive forces due to flexure; it need not be taken to be less than the greater of $0.9 d_e$ or $0.72h$ (in.)

in which:

$$d_e = \frac{A_{ps} f_{ps} d_p + A_s f_y d_s}{A_{ps} f_{ps} + A_s f_y} \quad (5.8.2.9-2)$$

Finding d_v

C5.8.2.9

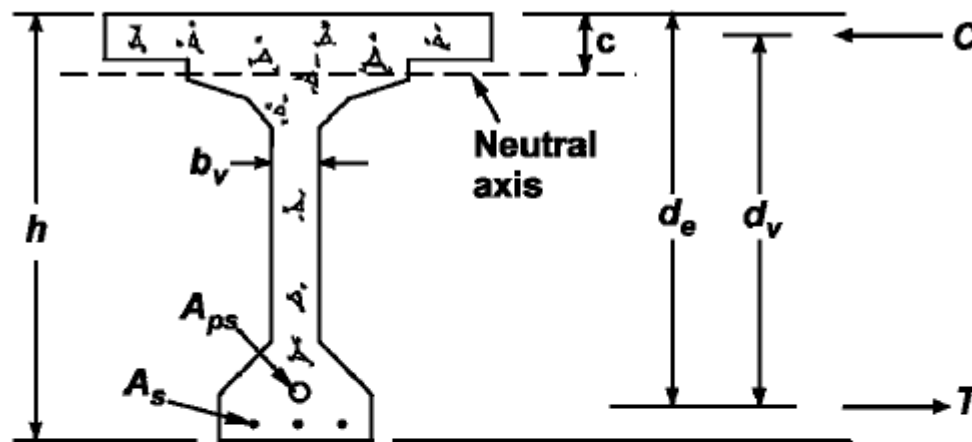

Figure C5.8.2.9-1—Illustration of the Terms b_v and d_v

For flexural members, the distance between the resultants of the tensile and compressive forces due to flexure can be determined as:

$$d_v = \frac{M_n}{A_s f_y + A_{ps} f_{ps}}$$

(C5.8.2.9-1)

5.8.3.3—Nominal Shear Resistance

The nominal shear resistance, V_n , shall be determined as the lesser of:

$$V_n = V_c + V_s + V_p \quad (5.8.3.3-1)$$

$$V_n = 0.25 f'_c b_v d_v + V_p \quad (5.8.3.3-2)$$

in which:

$$V_c = 0.0316 \beta \sqrt{f'_c} b_v d_v, \text{ if the procedures of Articles 5.8.3.4.1 or 5.8.3.4.2 are used} \quad (5.8.3.3-3)$$

V_c = the lesser of V_{ci} and V_{cw} , if the procedures of Article 5.8.3.4.3 are used

$$V_s = \frac{A_v f_y d_v (\cot \theta + \cot \alpha) \sin \alpha}{s} \quad (5.8.3.3-4)$$

where $\alpha = 90$ degrees, Eq. 5.8.3.3-4 reduces to:

$$V_s = \frac{A_v f_y d_v \cot \theta}{s} \quad (C5.8.3.3-1)$$

where:

- b_v = effective web width taken as the minimum web width within the depth d_v as determined in Article 5.8.2.9 (in.)
- d_v = effective shear depth as determined in Article 5.8.2.9 (in.)
- s = spacing of transverse reinforcement measured in a direction parallel to the longitudinal reinforcement (in.)
- β = factor indicating ability of diagonally cracked concrete to transmit tension and shear as specified in Article 5.8.3.4

- θ = angle of inclination of diagonal compressive stresses as determined in Article 5.8.3.4 (degrees); if the procedures of Article 5.8.3.4.3 are used, $\cot \theta$ is defined therein
- α = angle of inclination of transverse reinforcement to longitudinal axis (degrees)
- A_v = area of shear reinforcement within a distance s (in.²)
- V_p = component in the direction of the applied shear of the effective prestressing force; positive if resisting the applied shear; $V_p = 0$ when Article 5.8.3.4.3 is applied (kip)

5.8.3.4.3—Simplified Procedure for Prestressed and Nonprestressed Sections

For concrete beams not subject to significant axial tension, prestressed and nonprestressed, and containing at least the minimum amount of transverse reinforcement specified in Article 5.8.2.5, V_n in Article 5.8.3.3 may be determined with V_p taken as zero and V_c taken as the lesser of V_{ci} and V_{cw} , where:

V_{ci} = nominal shear resistance provided by concrete when inclined cracking results from combined shear and moment (kip)

V_{cw} = nominal shear resistance provided by concrete when inclined cracking results from excessive principal tensions in web (kip)

V_{ci} shall be determined as:

$$V_{ci} = 0.02\sqrt{f'_c}b_v d_v + V_d + \frac{V_i M_{cre}}{M_{max}} \geq 0.06\sqrt{f'_c}b_v d_v \quad (5.8.3.4.3-1)$$

where:

V_d = shear force at section due to unfactored dead load and includes both DC and DW (kip)

V_i = factored shear force at section due to externally applied loads occurring simultaneously with M_{max} (kip)

M_{cre} = moment causing flexural cracking at section due to externally applied loads (kip-in)

M_{max} = maximum factored moment at section due to externally applied loads (kip-in)

M_{cre} shall be determined as:

$$M_{cre} = S_c \left(f_r + f_{cpe} - \frac{M_{dnc}}{S_{nc}} \right) \quad (5.8.3.4.3-2)$$

where:

- f_{cpe} = compressive stress in concrete due to effective prestress forces only (after allowance for all prestress losses) at extreme fiber of section where tensile stress is caused by externally applied loads (ksi)
- M_{dnc} = total unfactored dead load moment acting on the monolithic or noncomposite section (kip-in.)
- S_c = section modulus for the extreme fiber of the composite section where tensile stress is caused by externally applied loads (in.³)
- S_{nc} = section modulus for the extreme fiber of the monolithic or noncomposite section where tensile stress is caused by externally applied loads (in.³)

In Eq. 5.8.3.4.3-1, M_{max} and V_i shall be determined from the load combination causing maximum moment at the section.

V_{cw} shall be determined as:

$$V_{cw} = (0.06\sqrt{f'_c} + 0.30f_{pc})b_vd_v + V_p \quad (5.8.3.4.3-3)$$

where:

f_{pc} = compressive stress in concrete (after allowance for all prestress losses) at centroid of cross section resisting externally applied loads or at junction of web and flange when the centroid lies within the flange (ksi). In a composite member, f_{pc} is the resultant compressive stress at the centroid of the composite section, or at junction of web and flange, due to both

V_p is part of V_{cw} by the method in Article 5.8.3.4.3 and thus V_p need be taken as zero in Eq. 5.8.3.3-1.

prestresses and moments resisted by precast member acting alone.

V_s shall be determined using Eq. 5.8.3.3-4 with $\cot \theta$ taken as follows:

where $V_{ci} < V_{cw}$:

$$\cot \theta = 1.0$$

where $V_{ci} > V_{cw}$:

$$\cot \theta = 1.0 + 3 \left(\frac{f_{pc}}{\sqrt{f'_c}} \right) \leq 1.8 \quad (5.8.3.4.3-4)$$

START

Given: b_v , d_v , M_{max} , f'_c , V_p , N_u , V_u , M_u , f_{pc} , f_{pu} , and A_p ,
where f'_c is in ksi

Increase
the section

yes

$$V_u > 0.18 f'_c b_v d_v + V_p$$

0.25

Reinforced concrete members

$$V_c = 0.06 \sqrt{f'_c} b_v d_v$$

Prestressed concrete members

V_c is the lesser of

$$V_{ci} = 0.02 \sqrt{f'_c} b_v d_v + \frac{V_i M_{cre}}{M_{max}} \geq 0.06 \sqrt{f'_c} b_v d_v$$

and

$$V_{cw} = (0.06 \sqrt{f'_c} + 0.30 f_{pc}) b_v d_v + V_p$$

where $M_{cre} = S_c (f_r + f_{cpe} - M_{dnc} / S_{nc})$.

Required shear strength for shear reinforcement:

$$V_s = V_u / \phi - V_c \text{ where } \phi = 0.9.$$

Web shear reinforcement:

$$A_v / s = \frac{V_s}{f_y d_v \cot \theta} \text{ or } (A_v / s)_{min}$$

whichever is larger. The value of $\cot \theta$ is taken as follows:

For reinforced concrete members:

$$\cot \theta = 1.0$$

For prestressed concrete members:

$$\text{If } V_{ci} < V_{cw} \text{ or } M_u > M_{cr} \quad \cot \theta = 1.0$$

$$\text{otherwise, } \cot \theta = 1.0 + 3 \frac{f_{pc}}{\sqrt{f'_c}} \leq 1.8.$$

END

Critical section for shear near the end support

According to S5.8.3.2, where the reaction force in the direction of the applied shear introduces compression into the end region of a member, the location of the critical section for shear is taken as the larger of $0.5d_v \cot \theta$ or d_v from the internal face of the support (d_v and θ are measured at the critical section for shear). This requires the designer to estimate the location of the critical section first to be able to determine d_v and θ , so a more accurate location of the critical section may be determined.

Based on a preliminary analysis, the critical section near the end support is estimated to be at a distance 7.0 ft. from the centerline of the end bearing. This distance is used for analysis and will be reconfirmed after determining d_v and θ .

Shear analysis for a section in the positive moment region

Sample Calculations: Section 7.0 ft. from the centerline of the end bearing

Determine the effective depth for shear, d_v

d_v = effective shear depth taken as the distance, measured perpendicular to the neutral axis, between the resultants of the tensile and compressive forces due to flexure; it need not be taken to be less than the greater of $0.9d_e$ or $0.72h$ (S5.8.2.9)

h = total depth of beam (in.)
= depth of the precast beam + structural slab thickness
= $72 + 7.5 = 79.5$ in. (notice that the depth of the haunch was ignored in this calculation)

d_e = distance from the extreme compression fiber to the center of the prestressing steel at the section (in.). From Figure 2-6,
= $79.5 - 5.375 = 74.125$ in.

Assuming rectangular section behavior with no compression steel or mild tension reinforcement, the distance from the extreme compression fiber to the neutral axis, c , may be calculated as:

$$c = A_{ps}f_{pu} / [0.85f_c\beta_1b + kA_{ps}(f_{pu}/d_p)] \quad (S5.7.3.1)$$

$$\beta_1 = 0.85 \text{ for 4 ksi slab concrete} \quad (S5.7.2.2)$$

$$\begin{aligned} b &= \text{effective flange width} \\ &= 111 \text{ in. (calculated in Section 2.2)} \end{aligned}$$

Area of prestressing steel at the section = $32(0.153) = 4.896 \text{ in}^2$

$$c = 4.896(270) / [0.85(4)(0.85)(111) + 0.28(4.896)(270/74.125)]$$

$$= 4.06 \text{ in.} < \text{ structural slab thickness} = 7.5 \text{ in.}$$

The assumption of the section behaving as a rectangular section is correct.

Depth of compression block, $a = \beta_1 c = 0.85(4.06) = 3.45$ in.

Distance between the resultants of the tensile and compressive forces due to flexure:

$$\begin{aligned} &= d_e - a/2 \\ &= 74.125 - 3.45/2 \\ &= 72.4 \text{ in.} \end{aligned} \quad (1)$$

$$\begin{aligned} 0.9d_e &= 0.9(74.125) \\ &= 66.71 \text{ in.} \end{aligned} \quad (2)$$

$$\begin{aligned} 0.72h &= 0.72(79.5) \\ &= 57.24 \text{ in.} \end{aligned} \quad (3)$$

$$d_v = \text{largest of (1), (2) and (3)} = 72.4 \text{ in.}$$

Notice that $0.72h$ is always less than the other two values for all sections of this beam. This value is not shown in Table 5.7-1 for clarity.

The End

AASHTO I Beams

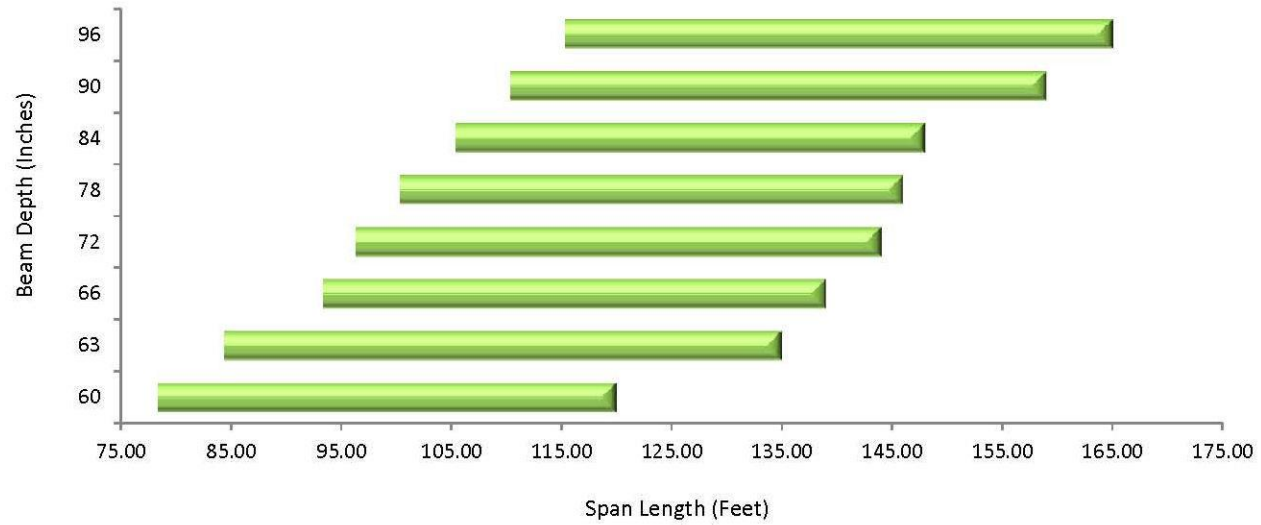

AASHTO I-BEAMS																				
				Depth Data (in.)						Flange Data (in.)				Basic Beam Properties						
Beam Designation	Top Flange Width (in.) W2	Bottom Flange Width (in.) W1	Depth (in.) D	T2	D1	B3	C	B1	T1	X1	B4	B2	Web Thickness (in.) W3	Conc. (CY/ft.)	Area (in. ²)	Yb (in.)	I (in. ⁴)	S _t (in. ³)	S _b (in. ³)	WT/FT. (KIPS)
28/63	42	28	63	5	3	4	33	10	8	13	4	10	8	0.261	1013	31.96	521162	16788	16308	1.057
28/66	42	28	66	5	3	4	36	10	8	13	4	10	8	0.267	1037	33.43	567180	18028	17564	1.081
28/72	42	28	72	5	3	4	42	10	8	13	4	10	8	0.279	1085	36.38	733319	20588	20157	1.130
28/78	42	28	78	5	3	4	48	10	8	13	4	10	8	0.291	1133	39.34	898984	23251	22854	1.178
28/84	42	28	84	5	3	4	54	10	8	13	4	10	8	0.304	1181	42.29	1085040	26016	25655	1.231
28/90	42	28	90	5	3	4	60	10	8	13	4	10	8	0.316	1229	45.26	1292348	28883	28557	1.280
28/96	42	28	96	5	3	4	66	10	8	13	4	10	8	0.328	1277	48.22	1521775	31850	31559	1.328

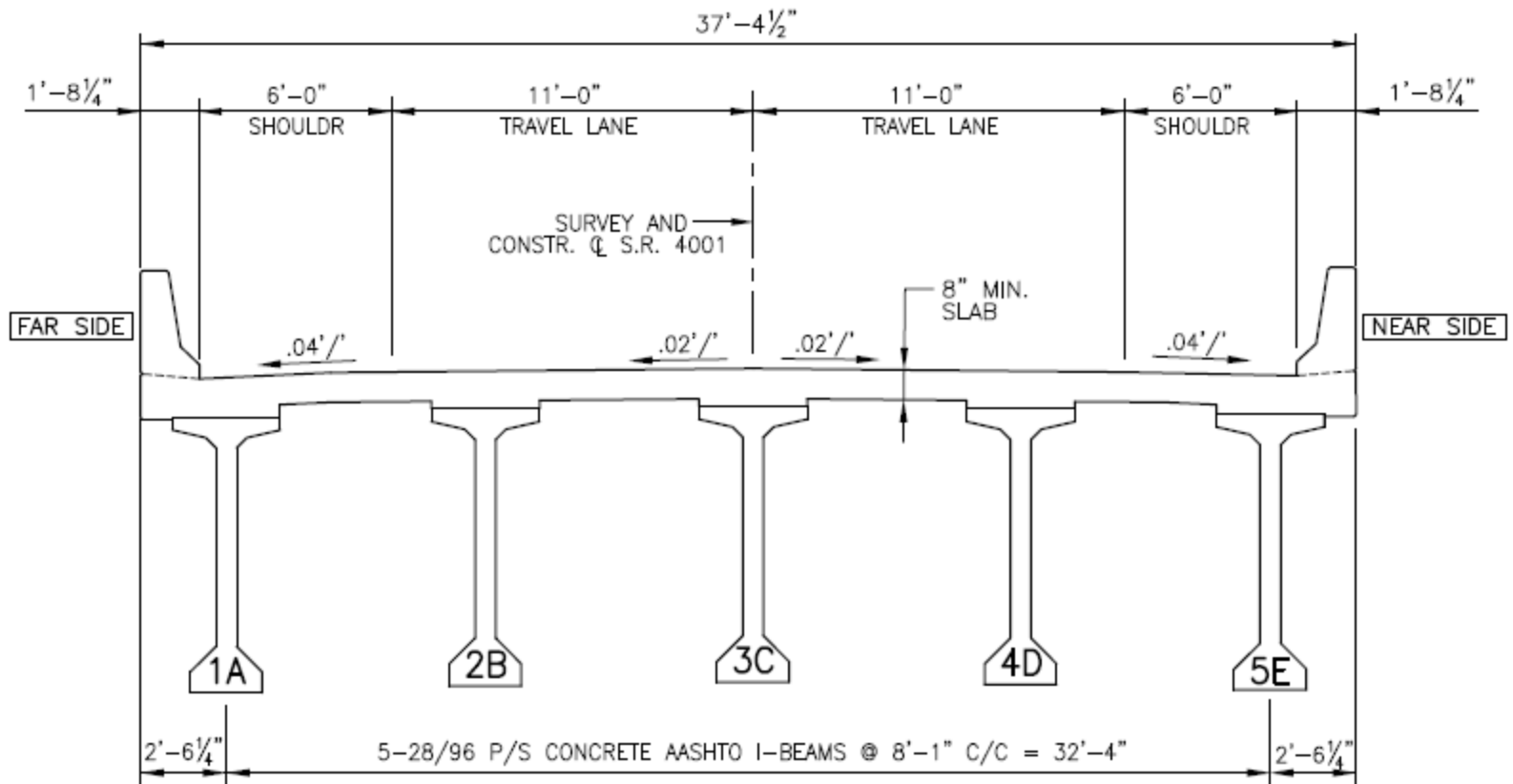

LOOKING STATIONS AHEAD
TYPICAL BRIDGE SECTION
 NO SCALE

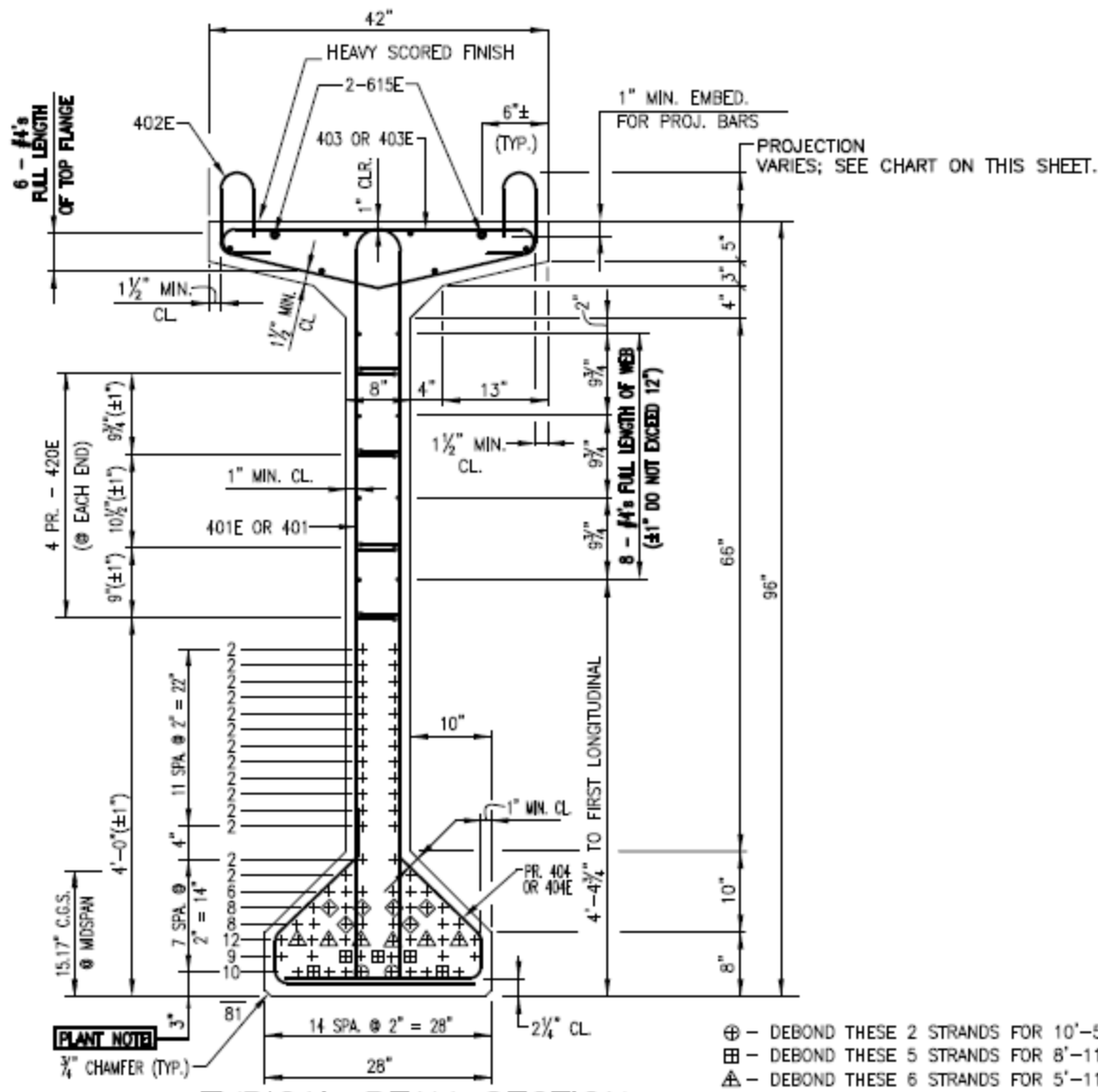

TYPICAL BEAM SECTION
NO SCALE

- ⊕ - DEBOND THESE 2 STRANDS FOR 10'-5" FROM BOTH ENDS OF BEAM.
- ⊞ - DEBOND THESE 5 STRANDS FOR 8'-11" FROM BOTH ENDS OF BEAM.
- ⊠ - DEBOND THESE 6 STRANDS FOR 5'-11" FROM BOTH ENDS OF BEAM.
- ⊕ - DEBOND THESE 6 STRANDS FOR 3'-11" FROM BOTH ENDS OF BEAM.

81- 1/2" Ø "SPECIAL" LOW RELAXATION STRANDS @ 33.82 K/STRAND

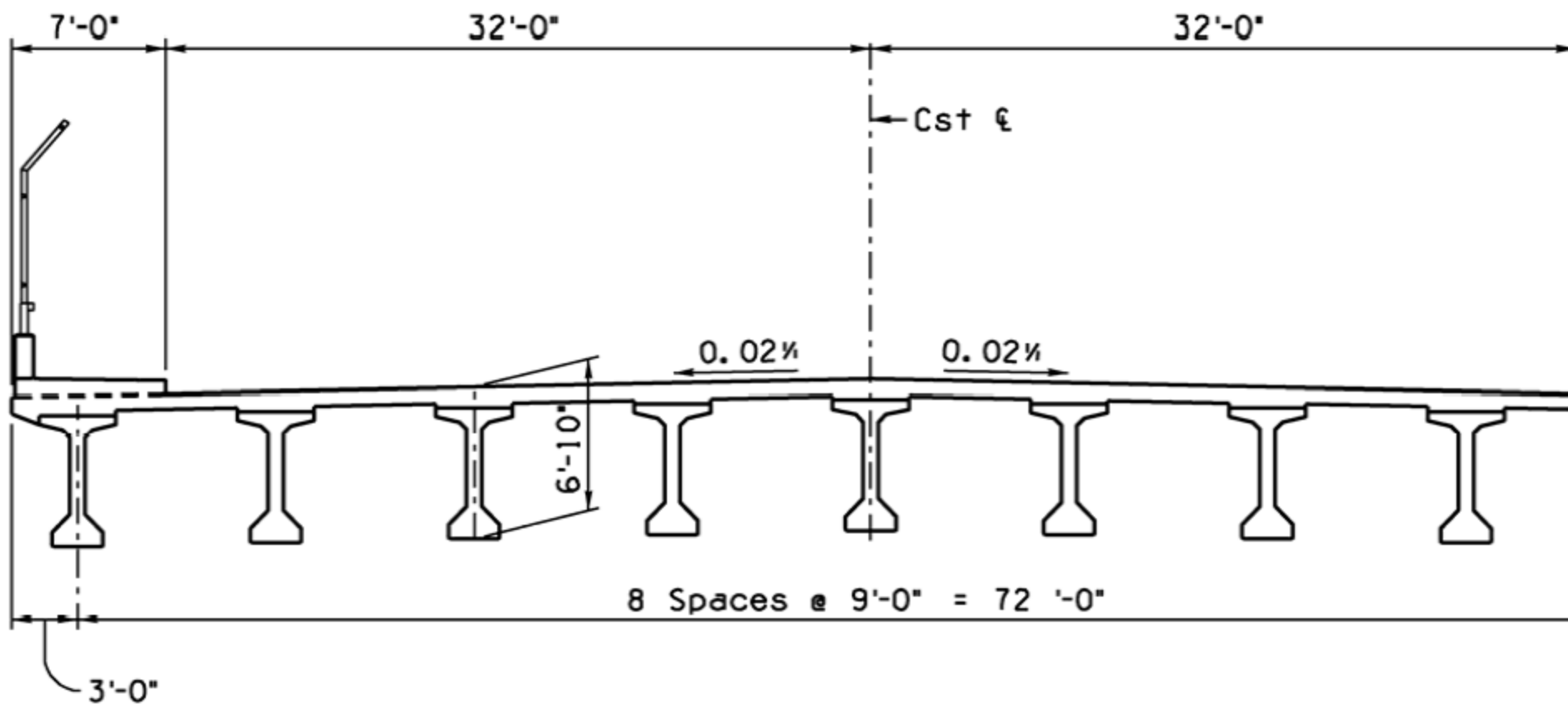

TYPICAL SECTION

Figure 2

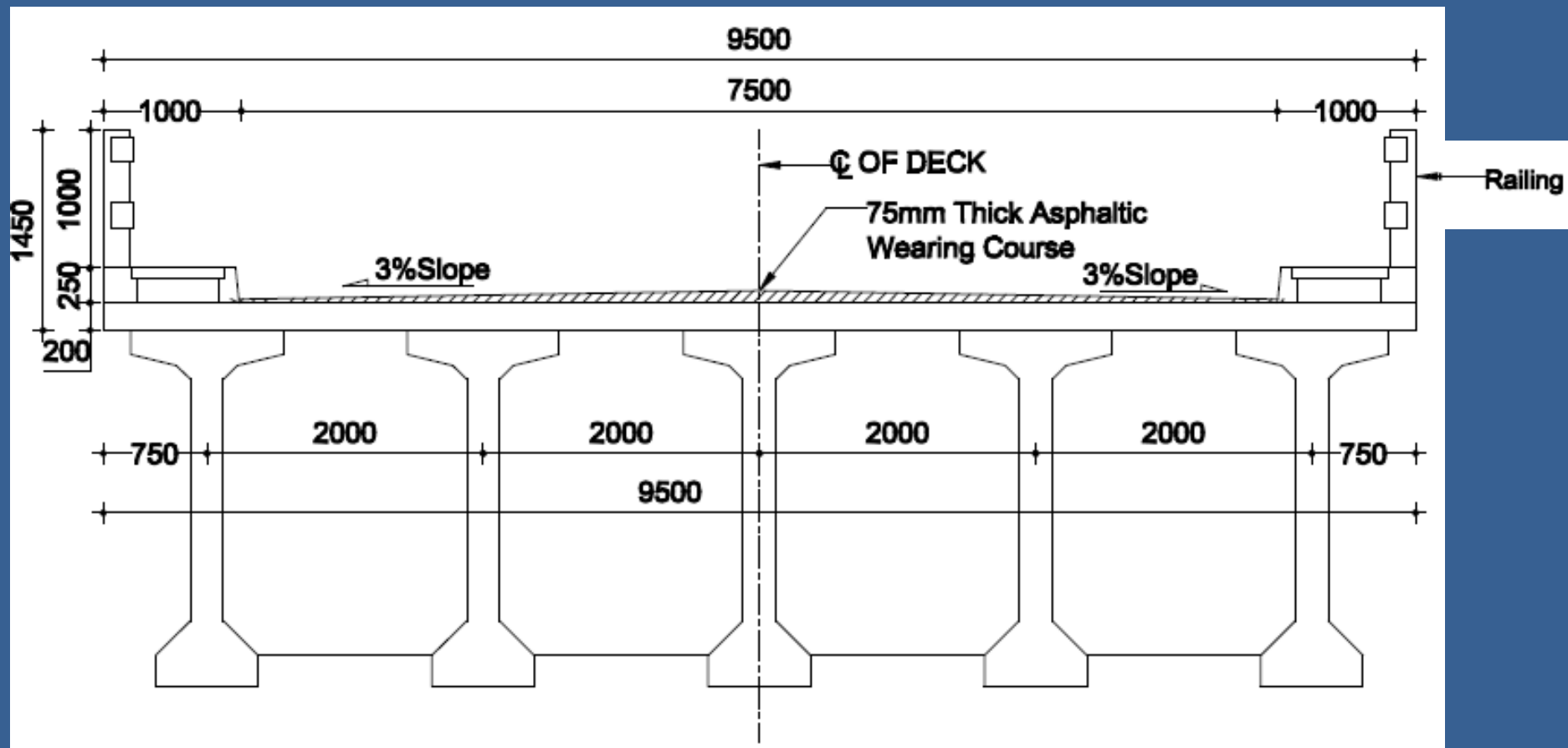

BRIDGE DECK SECTION A-A

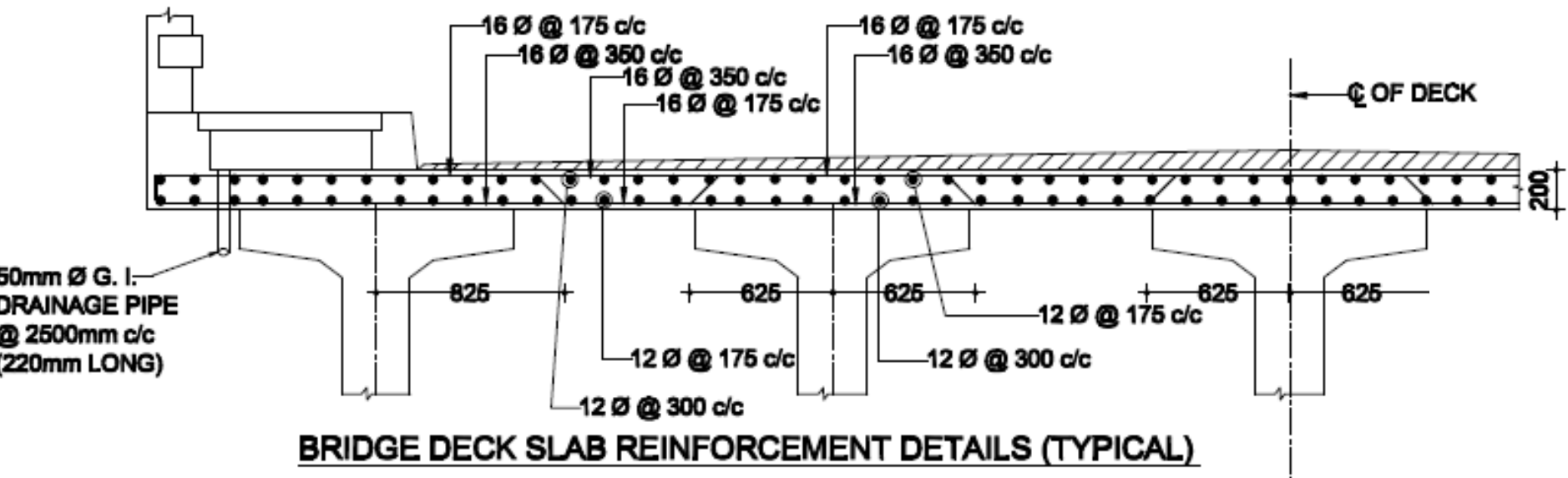

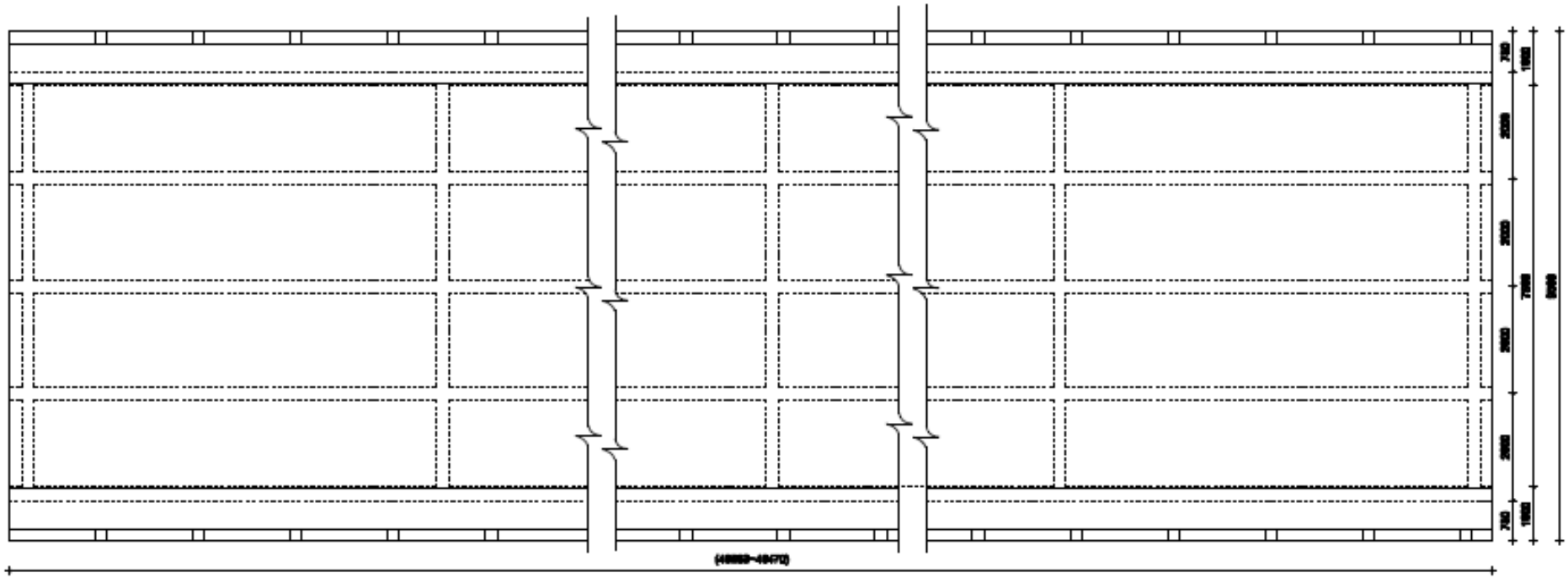

TYPICAL BRIDGE DECK PLAN

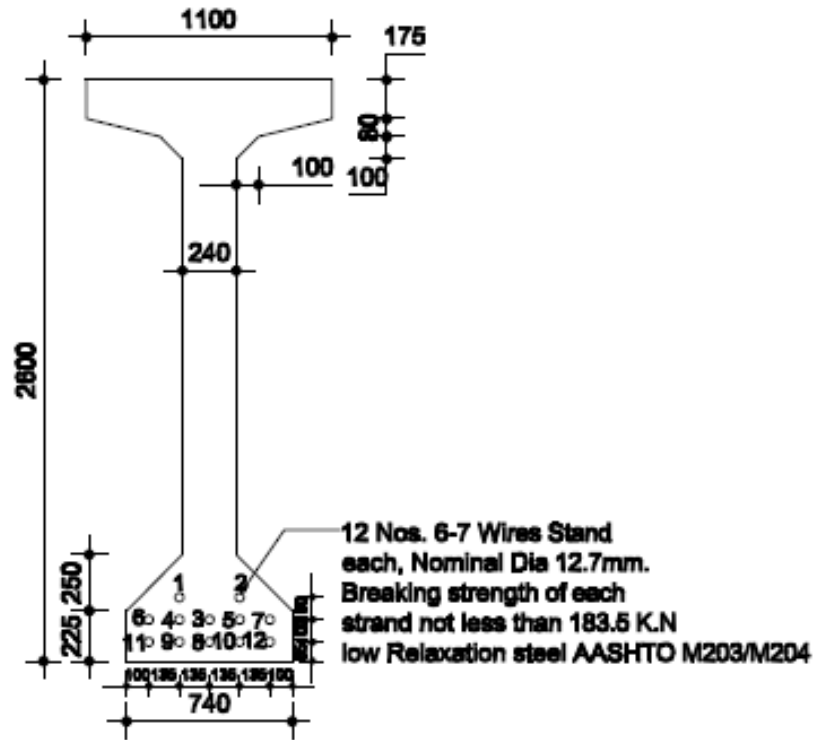
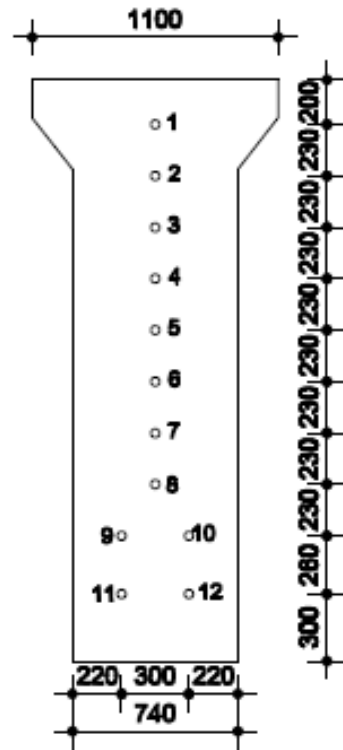
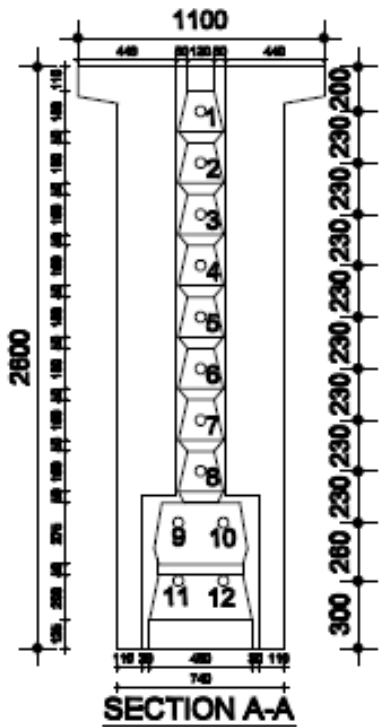

SECTION AT END
(SHOWING LOCATION OF CABLES)

SECTION AT C. L.
(SHOWING LOCATION OF CABLES)

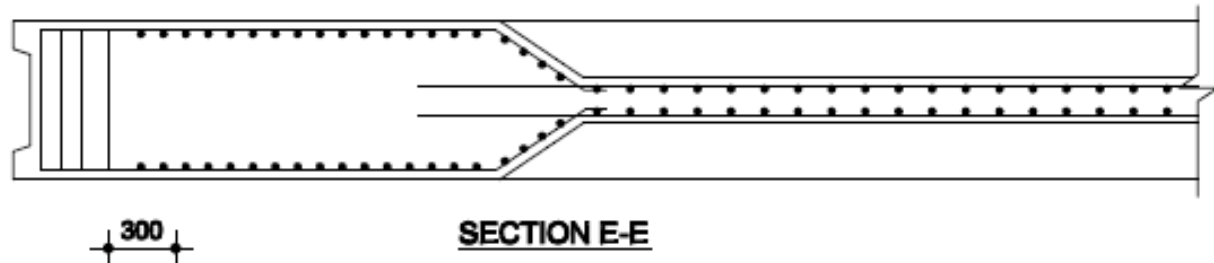

/ RELAXION

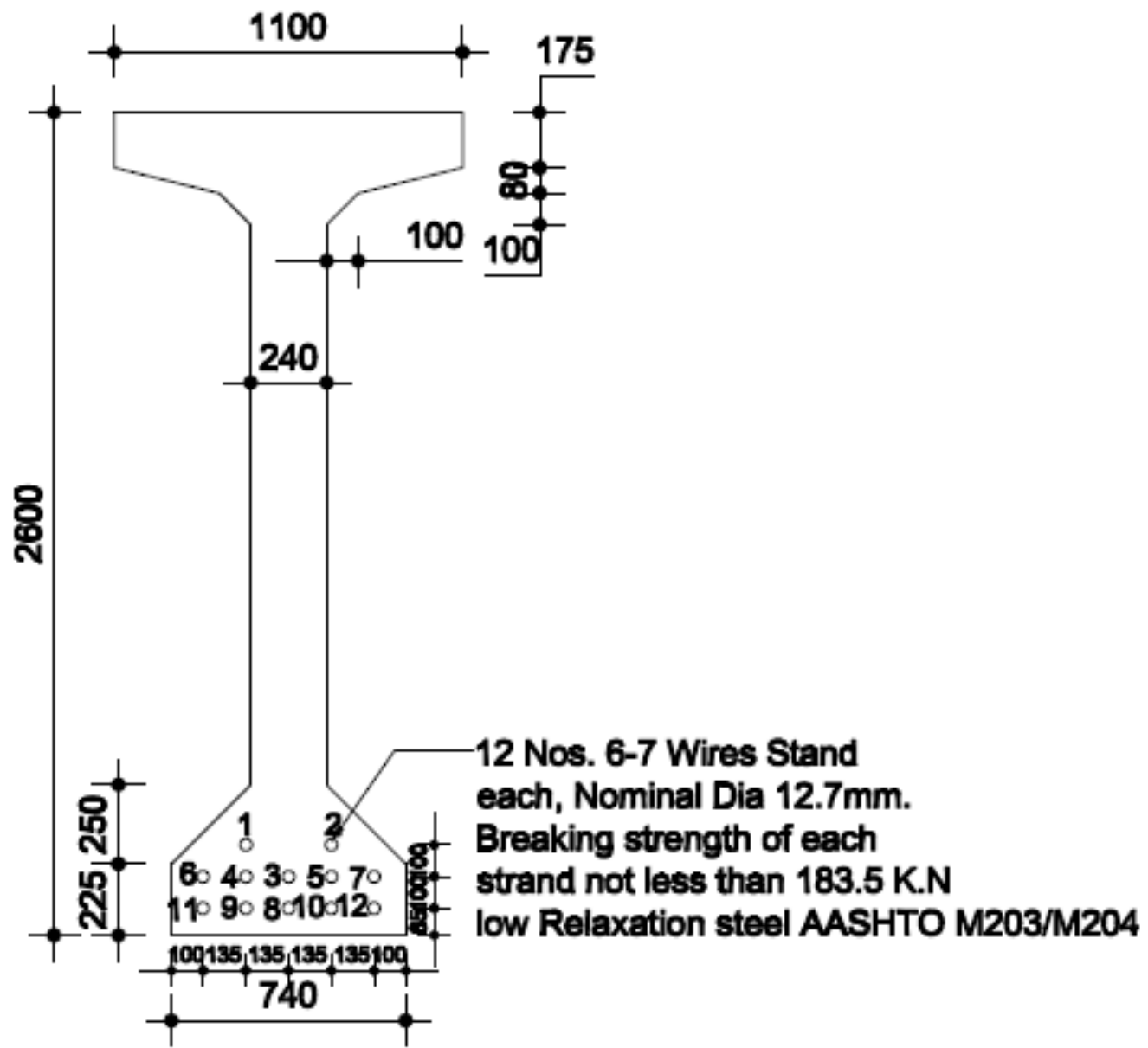

**SECTION AT C. L.
(SHOWING LOCATION OF CABLES)**

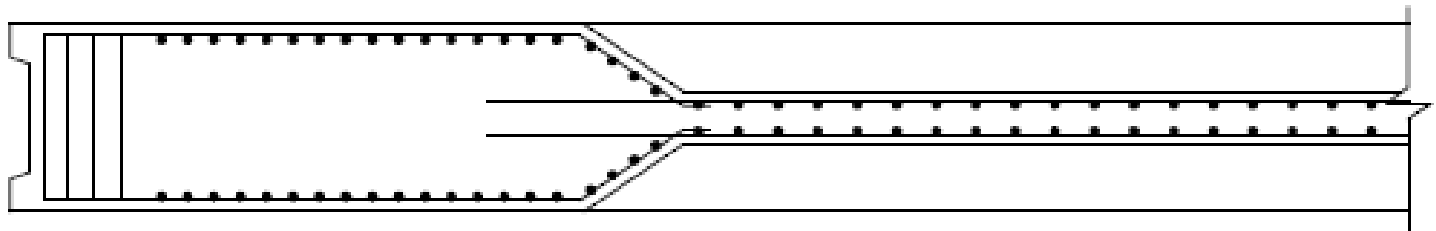

300

SECTION E-E

MESH(4 NOS)

E

E

THE FIRST MESH SHALL BE
 PLACED AT 30mm FROM THE
 IN SIDE FACE OF THE ANCHOR
 BEARING PLATE.

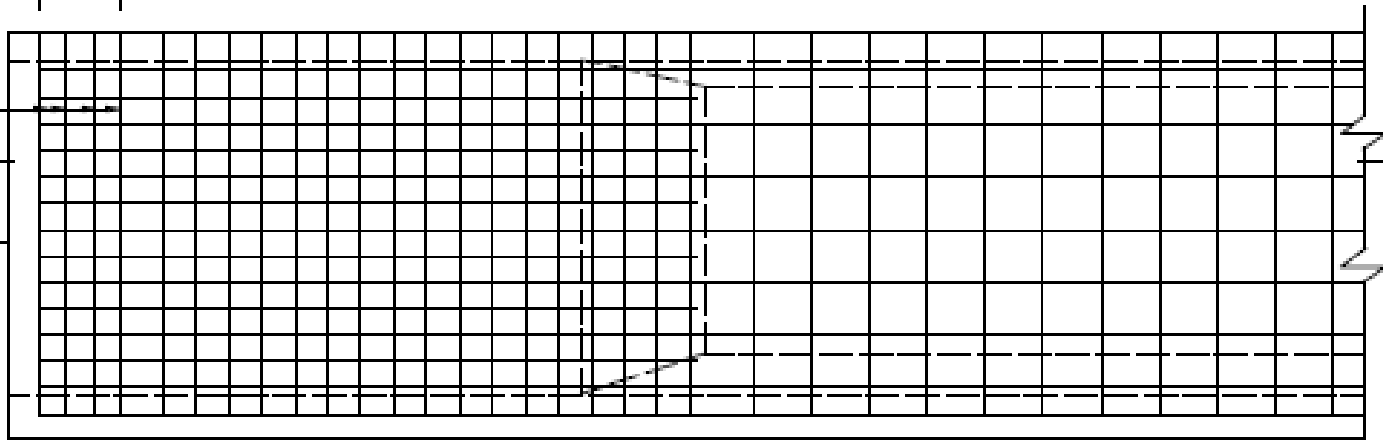

DETAIL OF END BLOCK

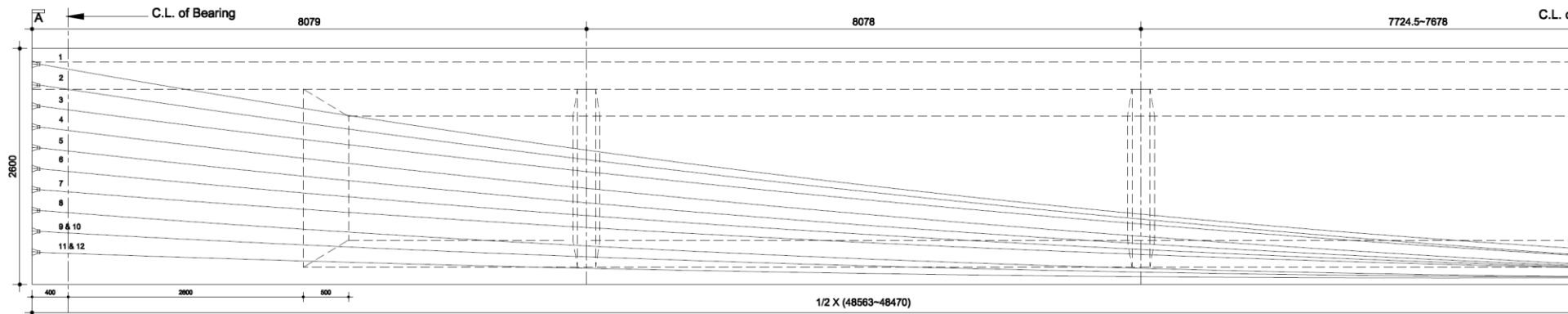

Distance of center line (mm)	0	2000	4000	6000	8000	10000	12000	14000	16000	18000	20000	22000	24000	24281.5-24235
Cable no. 1	285	299	343	415	515	645	804	991	1207	1452	1725	2028	2359	2400
Cable no. 2	285	298	336	401	490	606	747	914	1106	1325	1569	1838	2134	2170

HALF ELEVATION OF GIRDER SHOWING PRESTRESSING CABLE

Distance of center line (mm)	0	2000	4000	6000	8000	10000	12000	14000	16000	18000	20000	22000	24000	24281.5~24235
Cable no. 1	285	299	343	415	515	645	804	991	1207	1452	1725	2028	2359	2400
Cable no. 2	285	298	336	401	490	606	747	914	1106	1325	1569	1838	2134	2170
Cable no. 3	185	197	233	293	376	484	615	771	950	1153	1380	1631	1906	1940
Cable no. 4	185	195	227	278	351	445	559	694	850	1026	1224	1442	1681	1710
Cable no. 5	185	194	220	264	326	405	503	617	749	899	1067	1252	1455	1480
Cable no. 6	185	192	214	250	301	366	446	540	649	773	910	1063	1229	1250
Cable no. 7	185	191	208	236	276	327	390	464	549	646	754	873	1004	1020
Cable no. 8	85	90	104	128	162	205	258	320	392	474	565	666	776	790
Cable no. 9 & 10	85	88	98	114	137	166	201	243	292	347	408	476	551	560
Cable no. 11 & 12	85	86	91	98	108	122	138	157	179	204	231	262	296	300

CABLE PROFILE FROM SOFFIT OF GIRDER (Y CO-ORDINATES IN mm)

Distance of center line (mm)	0	2000	4000	6000	8000	10000	12000	14000	16000	18000	20000	22000	24000	24281.5~24235
Cable no. 1	-135	-114	-94	-76	-61	-47	-34	-24	-16	-9	-4	-1	0	0
Cable no. 2	+135	+114	+94	+76	+61	+47	+34	+24	+16	+9	+4	+1	0	0
Cable no. 3	0	0	0	0	0	0	0	0	0	0	0	0	0	0
Cable no. 4	-135	-114	-94	-76	-61	-47	-34	-24	-16	-9	-4	-1	0	0
Cable no. 5	+135	+114	+94	+76	+61	+47	+34	+24	+16	+9	+4	+1	0	0
Cable no. 6	-270	-228	-188	-152	-122	-94	-68	-48	-32	-18	-8	-2	0	0
Cable no. 7	+270	+228	+188	+152	+122	+94	+68	+48	+32	+18	+8	+2	0	0
Cable no. 8	0	0	0	0	0	0	0	0	0	0	0	0	0	0
Cable no. 9	-135	-135	-135	-136	-137	-138	-139	-140	-142	-143	-145	-147	-150	-150
Cable no. 10	+135	+135	+135	+136	+137	+138	+139	+140	+142	+143	+145	+147	+150	+150
Cable no. 11	-270	-251	-234	-218	-204	-191	-181	-171	-164	-158	-154	-151	-150	-150
Cable no. 12	+270	+251	+234	+218	+204	+191	+181	+171	+164	+158	+154	+151	+150	+150

NOTES:

CABLE PROFILE IN THE TRANSVERSE DIRECTION (X CO-ORDINATES IN mm)

NOTES:

CABLE PROFILE IN THE TRANSVERSE DIRECTION

1. 28 DAYS CYLINDER CRUSHING STRENGTH OF PRESTRESSED GIRDER SHALL BE $f_c=35$ MPa (5000 psi) AND CRUSHING STRENGTH OF CONCRETE AT THE TIME OF TRANSFER OF PRESTRESSING FORCE SHALL BE 28 MPa (4000 psi) MINIMUM.
2. STRESSING SEQUENCE OF CABLE 5, 6, 7, 8, 3, 4, 9,10, 1, 2, 11, 12.
3. ALL CABLES SHALL BE STRESSED FROM BOTH ENDS AT A TIME USING DOUBLE JACK TO REDUCE FRICTIONAL LOSS.
4. THE DATUM PRESSURE SHALL BE CORRECTLY DETERMINED FOR CABLE EXTENSION AND JACK PRESSURE PRIOR TO COMMENCEMENT OF TENSION.
5. AFTER TENSIONING OF ALL CABLES GROUTING SHALL BE INJECTED UNDER PRESSURE FROM ONE END UNTILL EJECTED FROM OTHER END. GROUTING PRESSURE SHALL BE 20KG/SQ
6. MINIMUM 28 DAYS COMPRESSIVE STRENGTH OF GROUT SHALL BE $f_c=25$ MPa AND SHALL CONSIST OF ORDINARY PORT LAND CEMENT, WATER AND ADMIXTURE.
7. COMPOSITION OF GROUT SHALL BE 50KG PORT LAND CEMENT, 17 LITRE OF WATER, 1KG OF APPROVED PLASTICIZER.

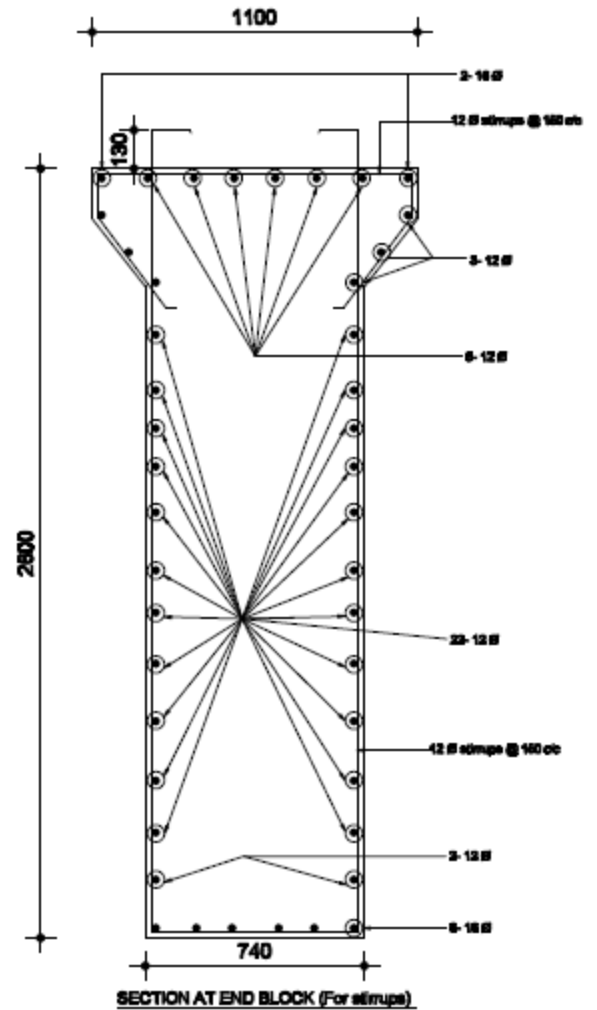
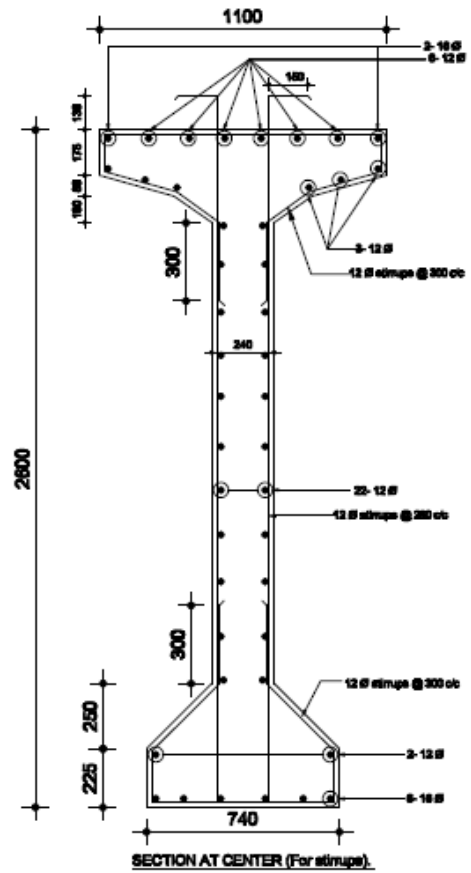

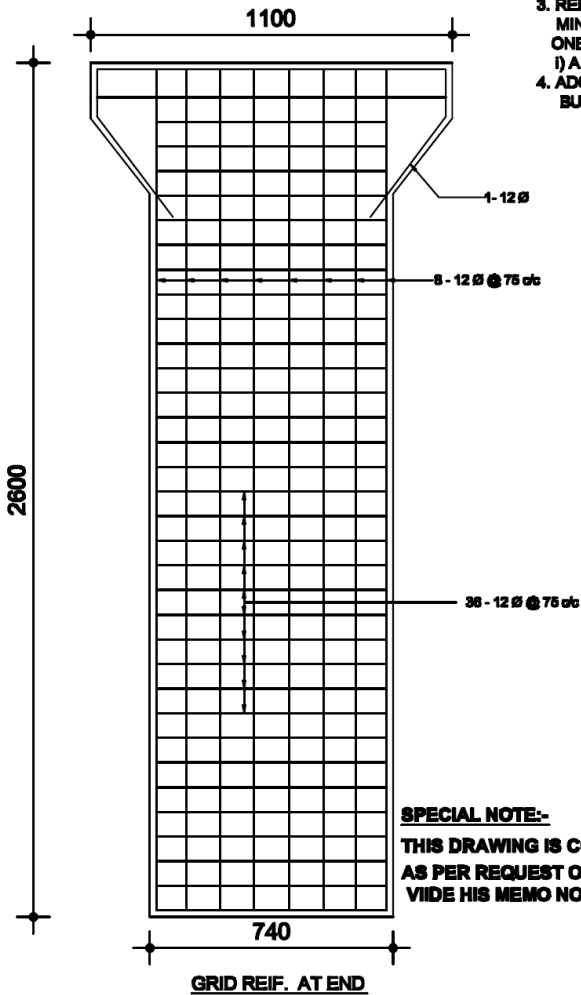

NOTE:

1. ALL DIMENSIONS ARE IN MILIMETER EXCEPT OTHER WISE MENTIONED.
2. CONCRETE SHALL HAVE A COMPRESSIVE STRENGTH $f_c=35 \text{ N/mm}^2$ (5000 p. s. l.) AT 28 DAYS ACCORDING TO ASTM C39.
3. REINFORCING BARS SHALL BE HIGH TENSILE DEFORMED BARS HAVING MINIMUM YIELD STRENGTH $f_y=415 \text{ N/mm}^2$ (60000 p. s. l.) CONFORMED TO ONE OF THE FOLLOWING ASTM SPECIFICATIONS.
i) A 615 M ii) A 616 M iii) A 706 M
4. ADOPTED FROM THE ORIGINAL DRAWING OF BRTC, BUET RI. NO. 5578/88-00/CE, DATE:22-06-2000

SPECIAL NOTE:-

THIS DRAWING IS COPIED FROM DRG. NO. B.D.D I/W $\frac{87}{2000}$ T, DATED:- 19-10-2000, AS PER REQUEST OF THE EXECUTIVE ENGINEER, RHD, ROAD DIVISION GOPALGONJ, VIIDE HIS MEMO NO. C-20/2032, DATED:-30-12-2009.

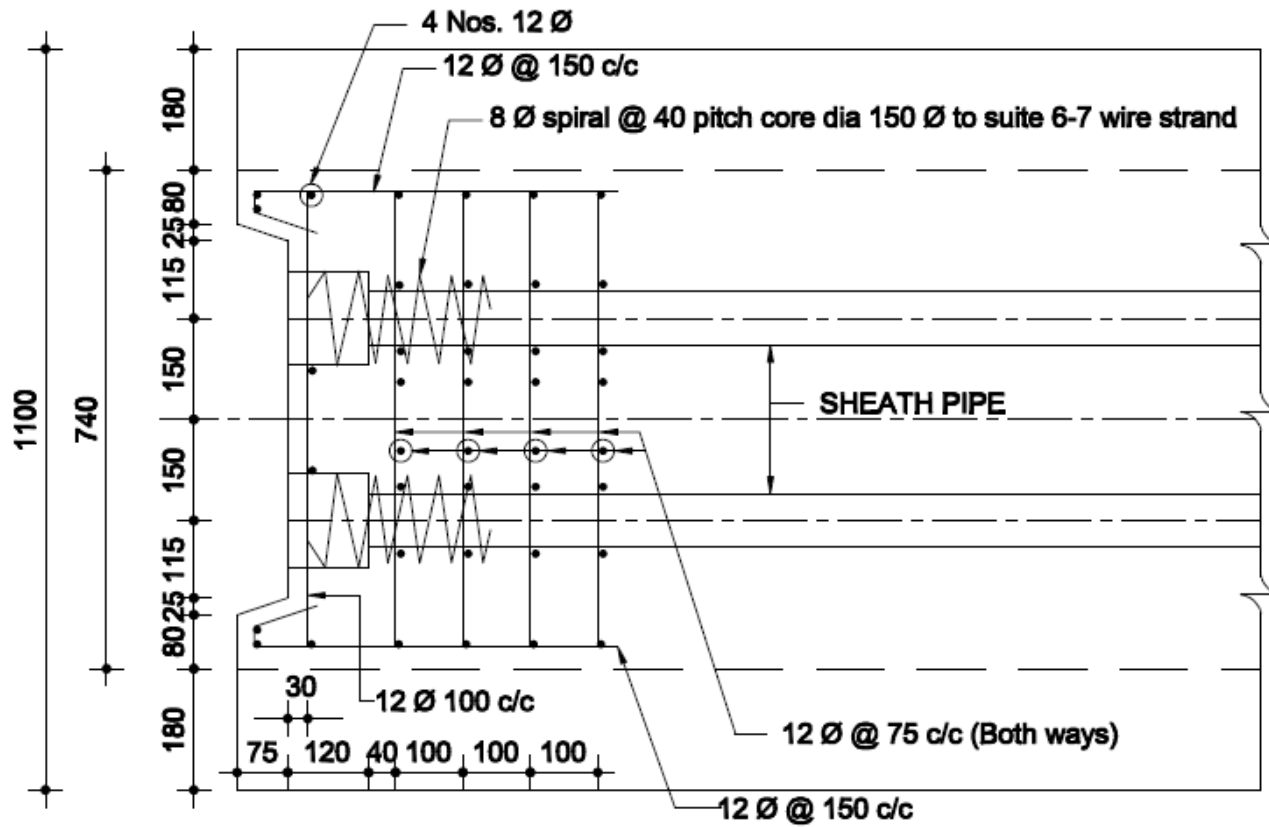

END BLOCK REINF. (For two cables)

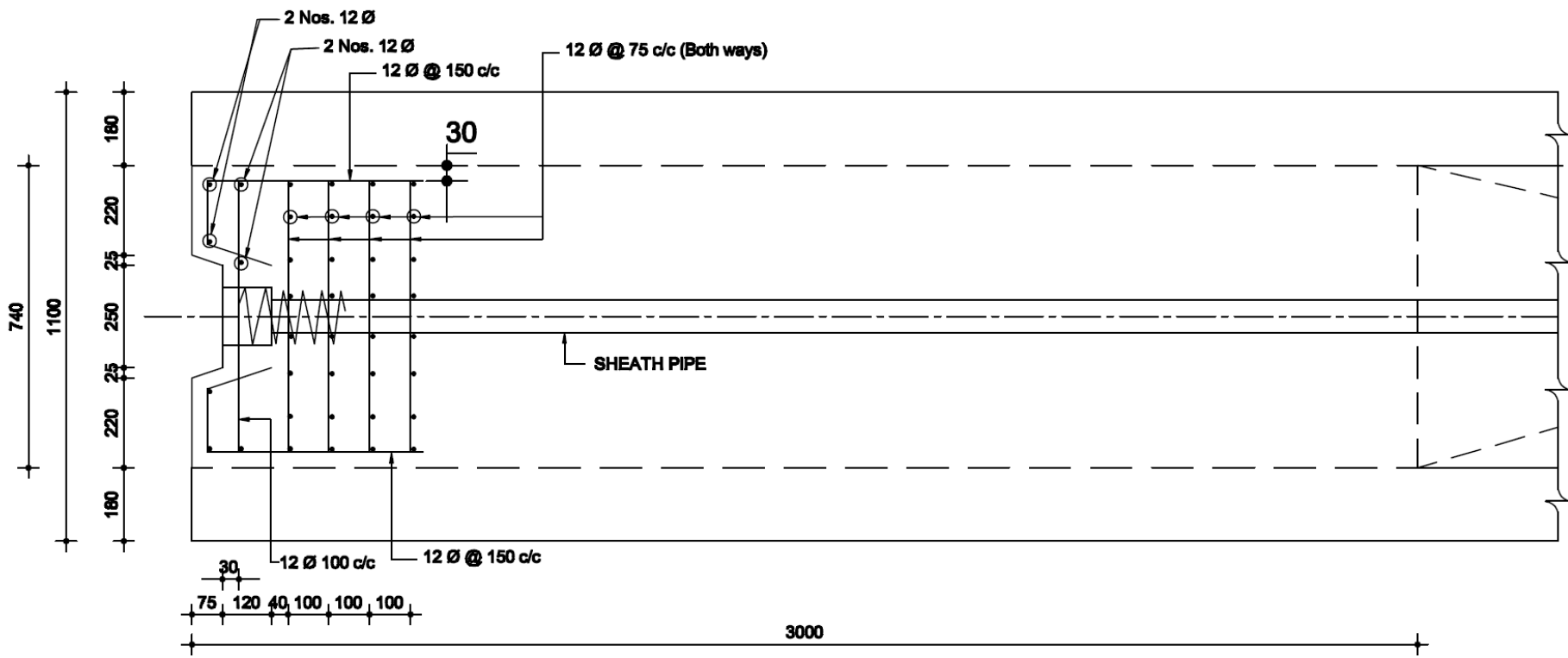

END BLOCK REINF. (For single cable)

DEAD LOAD CALCULATION

Calculate the dead load of the bridge superstructure components for the controlling interior girder. Values for the exterior girder have also been included for reference. The girder, slab, haunch, and exterior diaphragm loads are applied to the noncomposite section; the parapets and future wearing surface are applied to the composite section.

Interior girder

Girder weight

$$DC_{\text{girder (I)}} = A_g(\gamma_{\text{girder}})$$

where:

$$\begin{aligned} A_g &= \text{beam cross-sectional area (in}^2\text{)} \\ &= 1,085 \text{ in}^2 \end{aligned}$$

$$\begin{aligned} \gamma &= \text{unit weight of beam concrete (kcf)} \\ &= 0.150 \text{ kcf} \end{aligned}$$

$$\begin{aligned} DC_{\text{girder (I)}} &= (1,085/144)(0.150) \\ &= 1.13 \text{ k/ft/girder} \end{aligned}$$

Deck slab weight

The total thickness of the slab is used in calculating the weight.

$$\text{Girder spacing} = 9.667 \text{ ft.}$$

$$\text{Slab thickness} = 8 \text{ in.}$$

$$\begin{aligned} DC_{\text{slab (I)}} &= 9.667(8/12)(0.150) \\ &= 0.967 \text{ k/ft/girder} \end{aligned}$$

Concrete diaphragm weight

A concrete diaphragm is placed at one-half the noncomposite span length.

Location of the diaphragms:

Span 1 = 54.5 ft. from centerline of end bearing

Span 2 = 55.5 ft. from centerline of pier

For this example, arbitrarily assume that the thickness of the diaphragm is 10 in. The diaphragm spans from beam to beam minus the web thickness and has a depth equal to the distance from the top of the beam to the bottom of the web. Therefore, the concentrated load to be applied at the locations above is:

$$\begin{aligned} DC_{\text{diaphragm}} &= 0.15(10/12)[9.667 - (8/12)](72 - 18)/12 \\ &= 5.0625 \text{ k/girder} \end{aligned}$$

The exterior girder only resists half of this loading.

Parapet weight

According to the S4.6.2.2.1, the parapet weight may be distributed equally to all girders in the cross section.

Parapet cross-sectional area = 4.33 ft^2

$$\begin{aligned}DC_{\text{parapet}} &= 4.33(0.150) = 0.650 \text{ k/ft} \\ &= 0.650/6 \text{ girders} \\ &= 0.108 \text{ k/ft/girder for one parapet}\end{aligned}$$

Therefore, the effect of two parapets yields:

$$DC_{\text{parapet}} = 0.216 \text{ k/ft per girder}$$

Future wearing surface

Interior girder

$$\text{Weight/ft}^2 = 0.030 \text{ k/ft}^2$$

$$\text{Width} = 9.667 \text{ ft.}$$

$$\begin{aligned}DW_{\text{FWS (I)}} &= 0.030(9.667) \\ &= 0.290 \text{ k/ft/girder}\end{aligned}$$

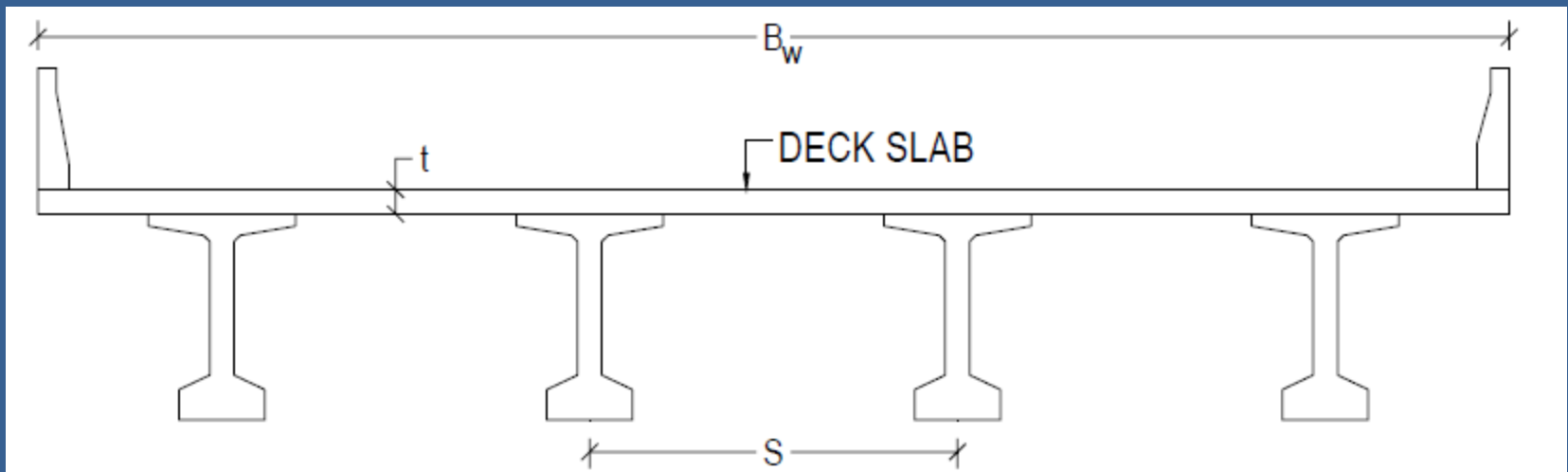

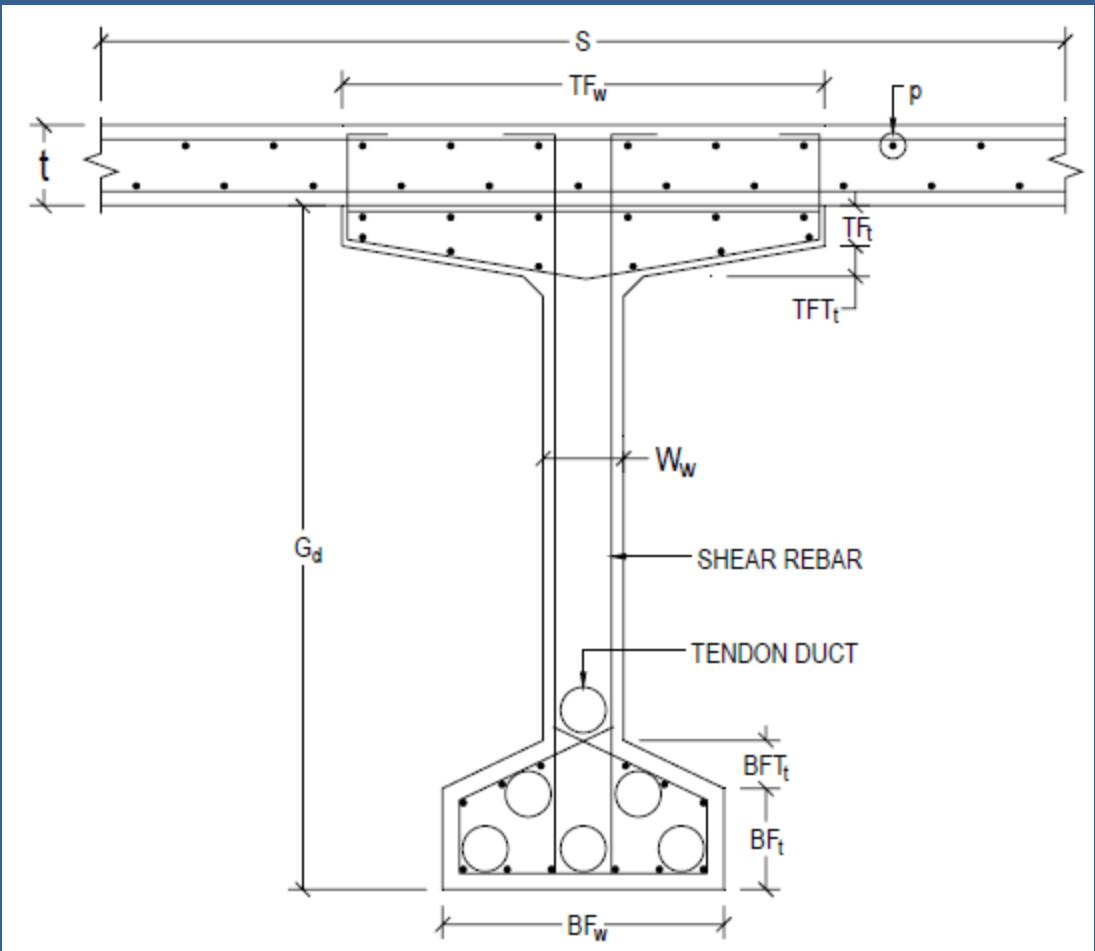

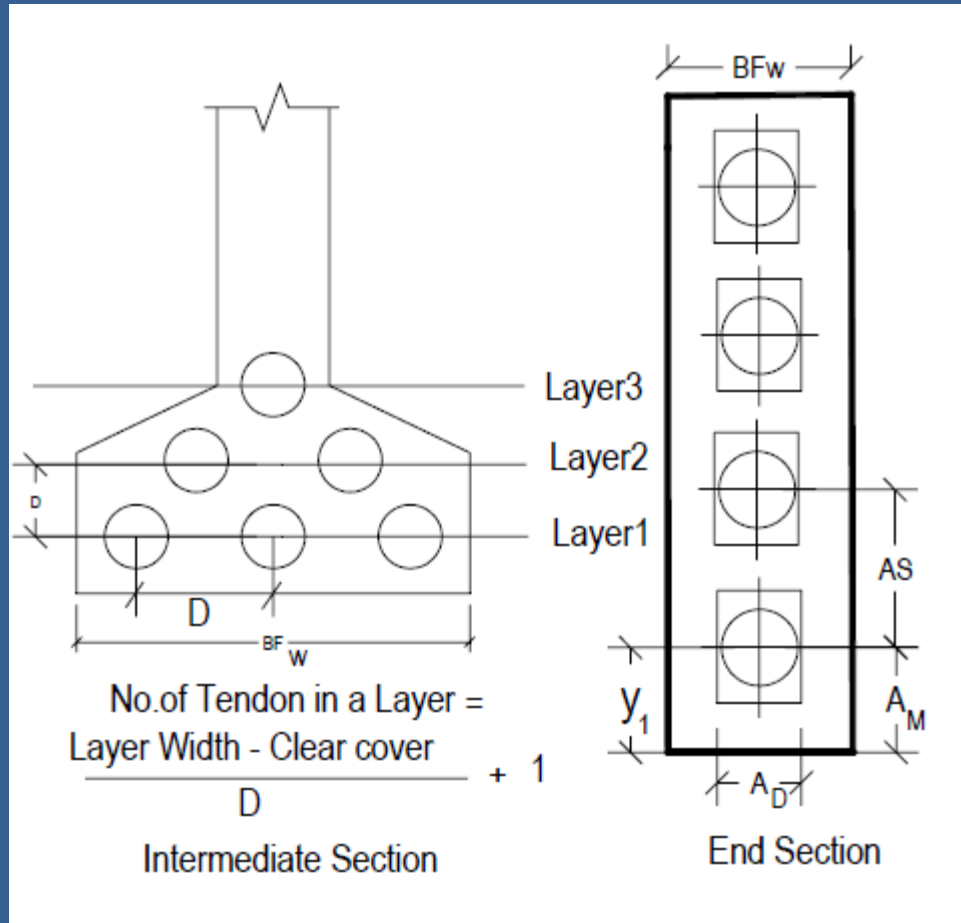

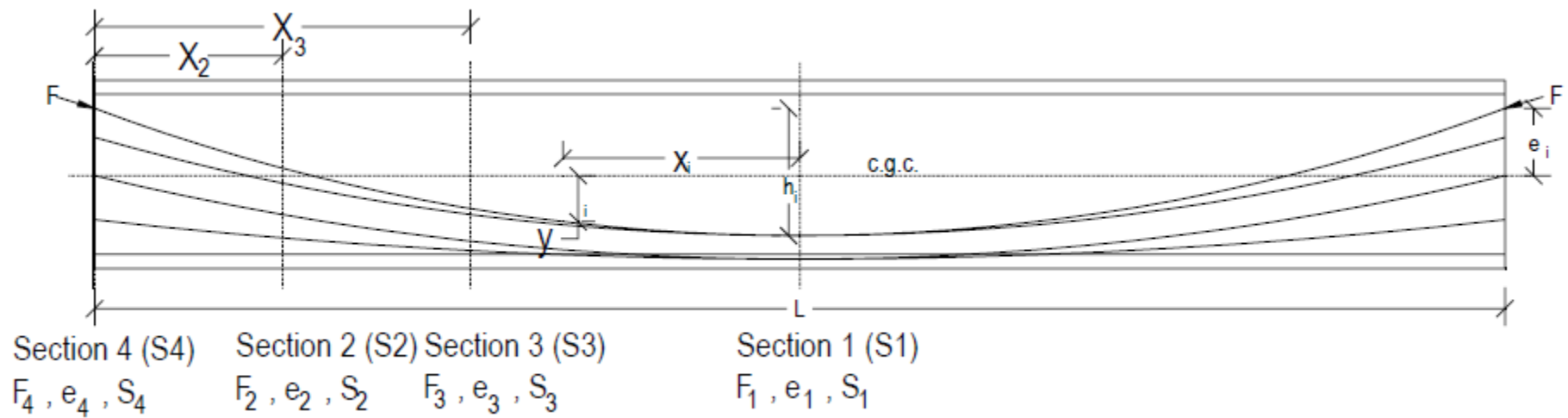

Minimum Cover

- Minimum clear cover for reinforcing steel and prestressing steel (5.12.3)
- Adjustments for Water-Cement Ratio:
 - For $W/C < 0.4$, the concrete tends to be dense; therefore can use only 80% of the value in the table (i.e. multiply by **0.8**)
 - For $W/C > 0.5$, the concrete tends to be porous; the value in the table must be increase by 20% (i.e. multiply by **1.2**)
- If there is no initial **overlay** of wearing surface, should add another 10 mm to the clear cover on the **top surface** to allows for some wear and tear

Table 5.12.3-1 - Cover for Unprotected Main Reinforcing Steel (mm)

SITUATION	COVER (mm)
Direct exposure to salt water	100
Cast against earth	75
Coastal	75
Exposure to deicing salts	60
Deck surfaces subject to tire stud or chain wear	60
Exterior other than above	50
Interior other than above	
● Up to No. 36 bar	40
● No. 43 and No. 57 bars	50
Bottom of cast-in-place slabs	
● Up to No. 36 bar	25
● No. 43 and No. 57 bars	50
Precast soffit form panels	20
Precast reinforced piles	
● Noncorrosive environments	50
● Corrosive environments	75
Precast prestressed piles	50
Cast-in-place Piles	
● Noncorrosive environments	50
● Corrosive environments	
- General	75
- Protected	75
● Shells	50
● Auger-cast, tremie concrete, or slurry construction	75

Strip Method

- Strip method is an approximate analysis method in which the deck is subdivided into strips perpendicular to the supporting components (girder)

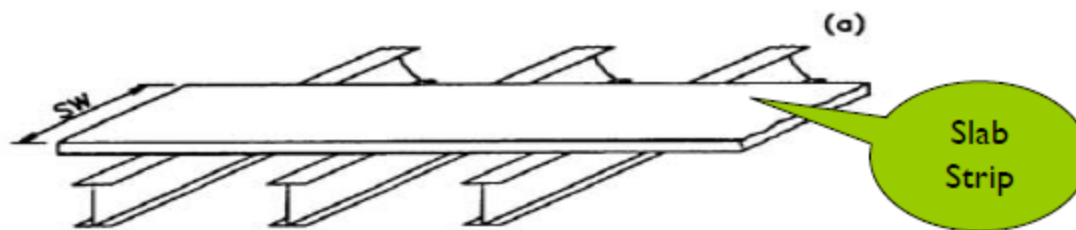

- The slab strip is now a continuous beam and can be analyzed using classical beam theory and designed as a one-way slab



Strip Method - Procedures

- ❑ Slab is modeled as beams and with girders as supports
- ❑ Wheel loads are placed (transversely) on this slab to produced the maximum effect

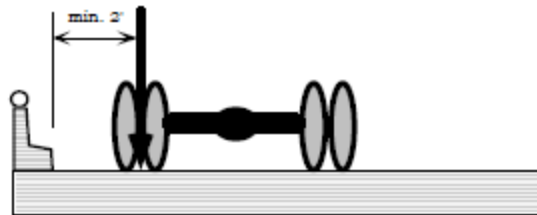

- ❑ Determine the maximum moment (M^+ and M^-) based on classical beam theory
- ❑ Determine the width of strip for each M^+ and M^- case
- ❑ Divide the maximum moment by the width of strip to get the moment per 1 unit width of slab
- ❑ Design an RC slab for this moment – the reinforcement required will be for 1 unit width of slab (this is for the *primary* direction)
- ❑ The reinforcement in the *secondary* direction may be taken as a percentage of those in the primary direction