

DO ANGLES HAVE GRADE?

BSRM Xtrong Grade 345 Angle



Why should you use BSRM Xtreme 345?

- BUET tested and produced from finest quality billet
- Perfect weight and standard quality
- 40% stronger and 20% cost efficient than ordinary angles
- Angle is straight and surface is smooth, hence low labor cost
- Perfect length, size and thickness
- Safe for welding
- More length per ton
- Edges are uniform so there is no wastage



UNIT WEIGHT, DIMENSIONS, AND LENGTH IN UNIT WEIGHT OF EQUAL LEG STEEL ANGLES AS PER BDS ISO 657-1:2008

LEG LENGTH (mm)	THICKNESS (mm)	AREA (mm ²)	UNIT MASS (Kg. / M)	LENGTH (Meter / Ton)	LENGTH (Feet / Ton)	KG / Feet	Feet / Kg.	MASS OF 20 FEET (Kgs.)
25	3	141	1.11	903.46	2963.4	.338	2.96	6.75
25	4	184	1.44	692.33	2270.8	.439	2.28	8.81
30	3	171	1.34	744.96	2443.5	.408	2.45	8.18
30	4	224	1.76	568.70	1865.3	.536	1.86	10.72
35	4	264	2.07	482.53	1582.7	.631	1.58	12.64
35	5	325	2.55	391.96	1285.6	.777	1.29	15.56
40	3	231	1.81	551.47	1808.8	.552	1.81	11.06
40	4	304	2.39	419.04	1374.5	.729	1.37	14.55
40	5	375	2.94	339.70	1114.2	.896	1.12	17.95
45	4	344	2.70	370.32	1214.6	.823	1.21	16.47
45	5	425	3.34	299.74	983.1	1.018	.98	20.34
50	4	384	3.01	331.74	1088.1	.918	1.09	18.38
50	5	475	3.73	268.19	879.7	1.137	.88	22.74
50	6	564	4.43	225.87	740.8	1.35	.74	27.00
60	5	575	4.51	221.55	726.7	1.375	.72	27.52
60	6	684	5.37	186.24	610.9	1.637	.61	32.74
60	8	896	7.03	142.17	466.3	2.14	.47	42.89
						0.00		
65	6	744	5.84	171.22	561.6	1.78	.56	35.61
65	8	976	7.66	130.52	428.1	2.33	.43	46.72
70	6	804	6.31	158.44	519.7	1.92	.52	38.48
75	6	864	6.78	147.44	483.6	2.07	.48	41.36
75	8	1136	8.92	112.14	367.8	2.72	.37	54.38
80	6	924	7.25	137.87	452.2	2.21	.45	44.23
80	8	1216	9.55	104.76	343.6	2.91	.34	58.20
80	10	1500	11.78	84.93	278.6	3.59	.28	71.80
90	7	1211	9.51	105.19	345.0	2.9	.35	57.96
90	8	1376	10.80	92.58	303.7	3.29	.30	65.86
90	9	1539	12.08	82.77	271.5	3.68	.27	73.66
90	10	1700	13.35	74.93	245.8	4.07	.24	81.37
100	8	1536	12.06	82.94	272.0	3.68	.27	73.52
100	10	1900	14.92	67.05	219.9	4.55	.22	90.94
100	12	2256	17.71	56.47	185.2	5.4	.18	107.98

SECTIONAL PROPERTIES OF EQUAL LEG ANGLES AS PER BDS ISO 657-1:2008

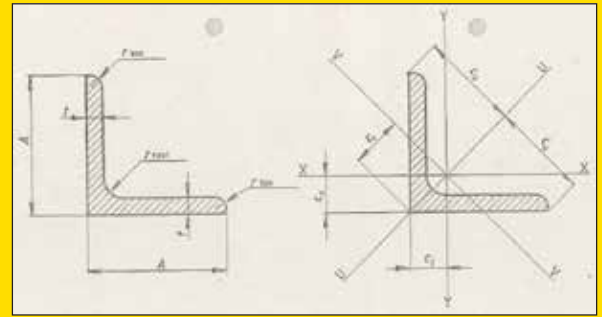

Designation	Mass kg/m	Sectional Area cm ²	Dimensions			Distances of Centre of gravity			Sectional Properties About Axes							
			A mm	t mm	r _{root} mm	Cx=Cy cm	Cu cm	Cv cm	X-X'=Y-Y'			U-U'		V-V'		
									I _x =I _y cm ⁴	I _{xy} =I _{yx} cm ⁴	I _{yz} =I _{zy} cm ⁴	I _u cm ⁴	I _v cm ⁴	I _{uv} cm ⁴	Z _v cm ³	
(1)	(2)	(3)	(4)	(5)	(6)	(7)	(8)	(9)	(10)	(11)	(12)	(13)	(14)	(15)	(16)	(17)
25 x 25 x 3 25 x 25 x 4	1.12 1.45	1.42 1.85	25 25	3 4	3.5 3.5	0.723 0.762	1.77 1.77	1.02 1.08	0.803 1.02	0.751 0.741	0.452 0.586	1.27 1.61	0.945 0.931	0.334 0.430	0.484 0.482	0.326 0.399
30 x 30 x 3 30 x 30 x 4	1.35 1.78	1.74 2.27	30 30	3 4	5 5	0.835 0.878	2.12 2.12	1.18 1.24	1.40 1.80	0.899 0.892	0.649 0.850	2.22 2.85	1.13 1.12	0.585 0.754	0.581 0.577	0.496 0.607
35 x 35 x 4 35 x 35 x 5	2.09 2.57	2.67 3.28	35 35	4 5	5 5	1.00 1.04	2.47 2.47	1.42 1.48	2.95 3.56	1.05 1.04	1.18 1.45	4.68 5.64	1.32 1.31	1.23 1.49	0.678 0.675	0.865 1.01
40 x 40 x 3 40 x 40 x 4 40 x 40 x 5	1.84 2.42 2.97	2.35 3.08 3.79	40 40 40	3 4 5	6 6 6	1.07 1.12 1.16	2.83 2.83 2.83	1.52 1.58 1.64	3.45 4.47 5.43	1.21 1.21 1.20	1.18 1.55 1.91	5.45 7.09 8.60	1.52 1.52 1.51	1.44 1.86 2.26	0.783 0.777 a0.773	0.949 1.17 1.38
45 x 45 x 4 45 x 45 x 5	2.74 3.38	3.49 4.30	45 45	4 5	7 7	1.23 1.28	3.18 3.18	1.75 1.81	6.43 7.84	1.36 1.35	1.97 2.43	10.2 12.4	1.71 1.70	2.68 3.26	0.876 0.871	1.53 1.80
50 x 50 x 4 50 x 50 x 5 50 x 50 x 6	3.06 3.77 4.47	3.89 4.80 5.69	50 50 50	4 5 6	7 7 7	1.36 1.40 1.45	3.54 3.54 3.54	1.92 1.99 2.04	8.97 11.0 12.8	1.52 1.51 1.50	2.46 3.05 3.61	14.2 17.4 20.3	1.91 1.90 1.89	3.73 4.55 5.34	0.979 0.973 0.968	1.94 2.29 2.61
60 x 60 x 5 60 x 60 x 6 60 x 60 x 8	4.57 5.42 7.09	5.82 6.91 9.03	60 60 60	5 6 8	8 8 8	1.64 1.69 1.77	4.24 4.24 4.24	2.32 2.39 2.50	19.4 22.8 29.2	1.82 1.82 1.80	4.45 5.29 6.89	30.7 36.1 46.1	2.30 2.29 2.26	8.03 9.44 12.2	1.17 1.17 1.16	3.46 3.96 4.86
65 x 65 x 6 65 x 65 x 8	5.91 7.73	7.53 9.85	65 65	6 8	9 9	1.80 1.89	4.60 4.60	2.55 2.67	29.2 37.5	1.97 1.95	6.21 8.13	46.3 59.4	2.48 2.46	12.1 15.6	1.27 1.26	4.74 5.84
70 x 70 x 6	6.38	8.13	70	6	9	1.93	4.95	2.73	36.9	2.13	7.27	58.5	2.68	15.3	1.37	5.60
75 x 75 x 6 75 x 75 x 8	6.85 8.99	8.73 11.4	75 75	6 8	9 9	2.05 2.14	5.30 5.30	2.90 3.02	45.8 59.1	2.29 2.27	8.41 11.0	72.7 93.8	2.89 2.85	18.9 24.5	1.47 1.46	6.53 8.09
80 x 80 x 6 80 x 80 x 8 80 x 80 x 10	7.34 9.63 11.9	9.35 12.3 15.1	80 80 80	6 8 10	10 10 10	2.17 2.26 2.34	5.65 5.66 5.68	3.07 3.19 3.30	55.8 72.2 87.5	2.44 2.43 2.41	9.57 12.6 15.4	88.5 115 139	3.08 3.06 3.03	23.1 29.9 36.4	1.57 1.56 1.55	7.55 9.37 11.0
90 x 90 x 7 90 x 90 x 8 90 x 90 x 9 90 x 90 x 10	9.61 10.9 12.2 15.0	12.2 13.9 15.5 17.1	90 90 90 90	7 8 9 10	11 11 11 11	2.45 2.50 2.54 2.58	6.36 6.36 6.36 6.36	3.47 3.53 3.59 3.65	92.5 104 116 127	2.75 2.74 2.73 2.72	14.1 16.1 17.9 19.8	147 166 184 201	3.46 3.45 3.44 3.42	38.3 43.1 47.9 52.6	1.77 1.76 1.76 1.75	11.0 12.2 13.3 14.4
100 x 100 x 8 100 x 100 x 10 100 x 100 x 12	12.2 15.0 17.8	15.5 19.2 22.7	100 100 100	8 10 12	12 12 12	2.74 2.82 2.90	7.07 7.07 7.07	3.87 3.99 4.11	145 177 207	3.06 3.04 3.02	19.9 24.6 29.1	230 280 328	3.85 3.83 3.80	59.9 73.0 85.7	1.96 1.95 1.94	15.5 18.3 20.9

NOTES:

1. Member countries may choose, to be included in their national standards, the sizes which are required to meet their demand. For the angles so chosen, only thicknesses which can be rolled in their mills to meet the demand of the users may be selected from the list of thicknesses corresponding to equal angles in BDS ISO 657-1: 2008 table 1.

2. The sectional area has been calculated using the formula

$$S = [(2A - t) - 0.2146(r^2 \text{root} - 2r^2 \text{toe})] \times 1/100$$

Where:

S is the sectional area, in square centimetres; t is the thickness, in millimetres;

r_{root} is the root radius, in millimetres; r_{toe} is the toe radius, in millimetres;

A is the leg length, in millimetres;

3. Mass is calculated on the basis of density of steel 7.85 kg/dm³.

STEEL CHEMISTRY FOR EQUAL LEG ANGLES AS PER ISO 630 – 3: 2012 (E)

Grade	C% max	Si% max	Mn% max	P% max	S% max	Cu% max	Ni% max	Cr% max	Mo% max	V% max	Nb% max	V+Nb% max	Ti% max
SG 345	0.20	0.55	1.60	0.035	0.04	b	b	b	b	b	b	b	b

'b' There is no specific requirement of these elements but the presence of these elements should be reported for C.E. value calculation of welding purpose.

Element	Range	Deviation
Carbon	>0.15 < 0.24	0.04
Silicon	< 0.55	0.05
Mn.	<1.70	0.10
Phos	< 0.04	0.01
Sulfur	<0.05	0.01

MECHANICAL PROPERTIES OF EQUAL LEG ANGLES AS PER ISO 630 – 3: 2012 (E)

Grade	Yield	Tensile	Eln%	Eln%	Eln%
	MPa	MPa	5D	2"	8"
SG 345	345	450 - 620	17	19	17

Elongation% values can be reported in either one of the 3 approved gauge lengths. The yield strength is minimum and the tensile strength has a minimum and maximum range

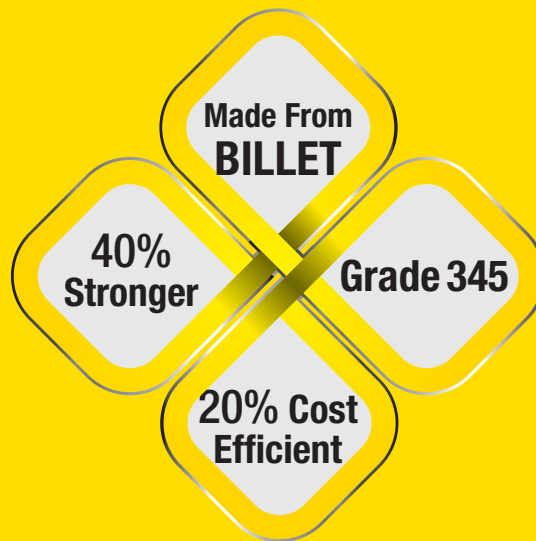

Corporate Office

Ali Mansion, 1207/1099 Sadarghat Road, Chittagong-4000, Bangladesh
Tel: +880 31 2854901-10, Fax: +880 31 610101
E-mail: mail@bsrm.com, Web: www.bsrm.com

Dhaka Corporate Office

Mahbub Castle (1st, 2nd & 4rd Floor), 35/A Purana Paltan Line, VIP Road, Dhaka-1000, Bangladesh
Tel: +880 2 8311994, 8313119, 8313135, 9344138, 9358135
Fax: +880 2 8312905, E-mail: dhaka@bsrm.com