

**LECTURE NOTES  
ON**

**CE 351: TRANSPORTATION ENGINEERING I:  
TRANSPORT & TRAFFIC DESIGN  
(3.00 CREDIT HOURS)**

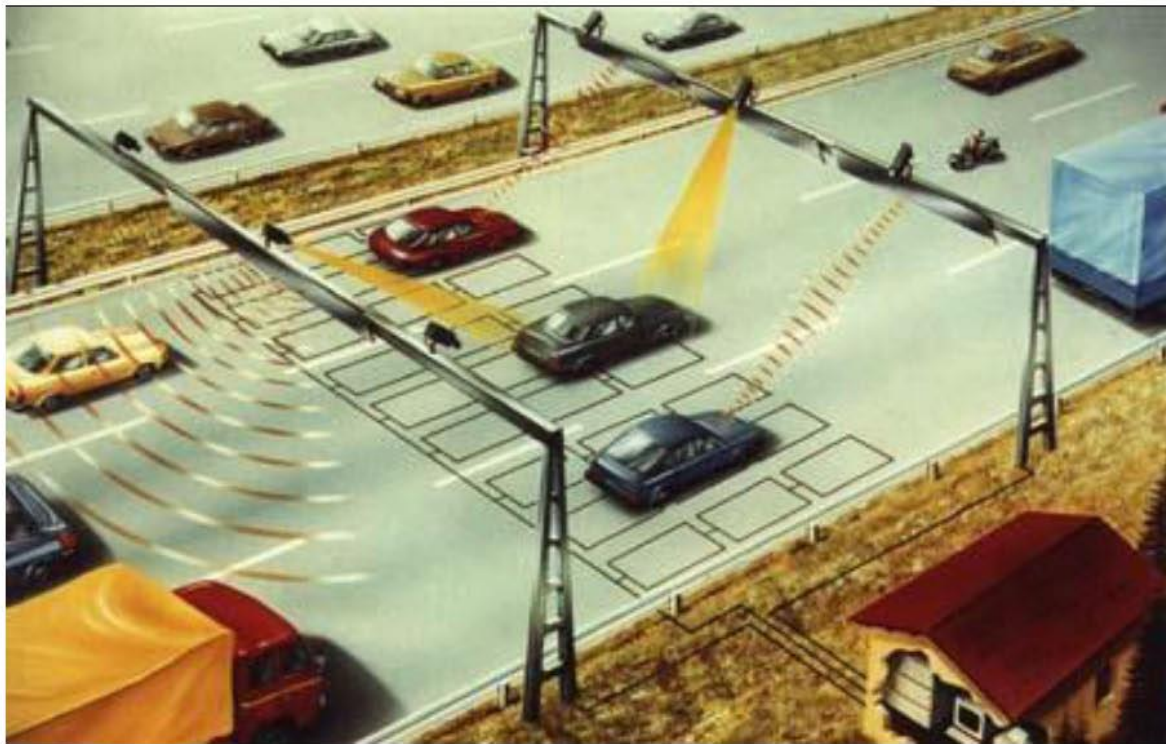

**BY  
PRF. DR. MD. SHAMSUL HOQUE**



**DEPARTMENT OF CIVIL ENGINEERING  
BANGLADESH UNIVERSITY OF ENGINEERING & TECHNOLOGY  
BUET, DHAKA-1000**

**CE 351: Transportation Engineering I: Transport & Traffic Design**  
(3.00 Credit)

**Syllabus**

***Dr. Alamgir M. Hoque***

- Introduction to transportation engineering;
- Development of transportation systems;
- Elements of transportation systems;
- Transportation in Bangladesh;
- Modal share

***Dr. Hasib M. Ahsan***

- Transport Planning concepts;
- Collection, study and analysis of basic data;
- Highway location and surveys;
- Geometric design of highways:
- Element of design,
- Cross-section elements,
- Curves and sight distances,
- Road intersections

***Dr. Shamsul Hoque***

- Traffic engineering:
- The road/traffic system,
- Vehicle and traffic characteristics;
- Traffic control devices;
- Traffic studies;
- Parking; Roadway lighting; and
- Terminals.

**Class Distribution**

Class 1	Introduction
Class 2	Traffic Engineering
Class 2 & 3	The Road/traffic System
Class 3 & 4	Vehicle and Traffic Characteristics
Class 5, 6, & 7	Traffic Studies

Class Test 1

Class 8 & 9	Traffic Control Devices
Class 10 & 11	Parking

Class Test 2

Class 12	Lighting
Class 13	Terminals
Class 14	Overview

### Reference books

**Kadiyali, L.R.,**

"Traffic Engineering and Transport Planning", Second Edition, 1983.

**Singh, G. C.,**

"Highway Engineering", Third Edition, 1991.

**Wright, P.H. and Paquette, R.J.**

"Highway Engineering", Fifth Edition, 1993.

**O'Flaherty, C.A.,**

"Highways and Traffic", Volume 1, Second Edition, 1983.

**Matson, M.T. and Hurd, W.F.,**

"Traffic Engineering", McGraw-Hill, 1955.

## Modern Trend in Transport Industry

### Main Objectives

- Control of trip demands
- Distribution of peak periods
- Encouraging public, bicycle and walking modes

### Modern Trend

- Planning & policies**
  - Integrated land use and transport planning
  - Modular city & zonal concept (self-contained)
  - Multipurpose usage of same r.o.w
  - Segregated Public transport facilities (Automatic People Mover)
  - Integrated walking and bike facilities
  - Restricting private modes
  - IT based communication backbone coupled with smart policies viz. paper less administration/services, place independent jobs, virtual shopping, e-bank, e-commerce, distant education system etc.
- Construction**
  - Built Operate and Transfer (BOT) concept
  - Auto soil compaction
  - Use of Modified binder
  - Recycling
- Intelligent Transport System (ITS)**
  - Smart Road
    - Magnetic vehicle track
    - Equipped with roadside/embedded/gantry - fiber optics, sensors, detectors, beckon, VMS, CCTV, etc.
  - Smart Vehicle
    - Built-in telematics
    - Built-in safety features
    - Auto emergency phone
    - Built-in theft proof feature
    - Renewable fuel (echo friendly vehicle)
- Public Transport**
  - Driver-less, demand responsive, non-stop, fast, smart payment
  - Interactive passenger information system
- Traffic Control & Management**
  - Dynamic drivers & passengers information system
  - Demand responsive & adaptive traffic control system
  - Auto toll/Congestion pricing (virtual toll plaza: smart card & transponder)
  - Auto surveillance
  - Dynamic fleet management system

### Factors which make ITS feasible are:

- Smart on-line remote data acquisition and transmission devices**
  - Satellite communication (GSM)
  - Global Positioning System (GPS)
  - Detectors/sensors/beckons
  - Auto detection technique – machine vision image processing & pattern recognition
- Smart on-line data processing and storage devices**
  - Fast & compact computer
  - Compact Disk (CD)
- Smart on-line information system**
  - Internet/Information Technology (IT)
  - Geographical Information System (GIS)

## TRAFFIC ENGINEERING

### Definition

Traffic engineering is the science of

- ❑ measuring traffic and travel, the study of basic laws relating to traffic flow and generation, and
- ❑ application of this knowledge to the professional practice of planning, designing, and operating traffic systems to achieve safe, efficient and convenient movement of persons and goods.

### History

- ❑ Traffic Engineering as it is known today has evolved gradually with increase in traffic (veh. & ped.)
- ❑ Initially it was limited to application of simple rules and regulations such as left driving rule, road signs, marking, and intersection control by flag etc.
- ❑ Subsequent analysis of traffic operations and road accidents led to the realization the traffic regulations and other methods of traffic control should be based on proper engineering studies.
- ❑ In consequence as extension of traffic regulations - many new traffic control and management techniques were devised viz. speed zoning, traffic signals, turn restrictions, parking restrictions, bus priorities, one-way street etc.
- ❑ Eventually it become evident that the planning and design of efficient road network largely depends upon the integrated land-use & transport policies and effective demand management (road pricing to control & distribution peak hours)
- ❑ Modern traffic engineering measures are mostly restrictive and dynamic in nature and largely depend on public transport facilities and information technology (IT).

### Objectives

- ❑ to improve overall roadway capacity
- ❑ to ensure safety
- ❑ since both vehicle-vehicle and vehicle-pedestrian conflicts reduce roadway capacity and cause accident risk – overall objective is to minimize these conflicts so as to make the most economic use of the existing roadway facilities

### Traffic engineering includes

- ❑ studies and analysis of traffic characteristics and flow parameters
  - ❑ geometric design (mainly improvement)
  - ❑ planning of regulatory measures
  - ❑ design and application of control devices
- ❑ functional planning of road network

### Why TE is so essential now-a-days?



Because of

- ❑ Increased urbanization process
- ❑ Increased traffic demand - phenomenal growth in traffic specially within urban areas
- ❑ Difficulties in expanding roadway facilities within built up areas
- ❑ Congestion become chronic in every where
- ❑ Increased air pollution
- ❑ Increased accident numbers
- ❑ Road network become larger

Therefore, there is a need to maximize the utilization of existing facilities by better traffic management and control measures.

### Bottlenecks - Causes of congestion

For better management of road network, the traffic engineers must know the common causes of congestion and accident.

#### Causes of Congestion

##### *External (geometric) Factors*

- ❑ road intersections
- ❑ railway crossings
- ❑ narrow road/bridge/culverts
- ❑ inconsistent roadway width
- ❑ poor turning radius
- ❑ side frictions
  - ❑ scattered parking/non-motor activities along road
  - ❑ frequent side roads entries

- bus stops/parking near junctions
- road side cut/unfinished repair of road side pavement
- poor roadway environment
  - poor road discipline
  - uncontrolled pedestrian crossing
  - poor road surface condition
  - speed breaker
  - poor sight distance
  - poor lighting
  - poor drainage facility

**Internal (traffic) factors**

- heterogeneous traffic stream
- high volume of traffic (demand > capacity)

**Safety problems arise mainly**

**from conflicts:**

- at intersections
- along on-street parking
- where pedestrian activities are high
- at blind spots - viz. bends, spots with poor sight distance/lighting facilities etc.

**due to:**

- poor road surface condition
- faulty road geometry
- poor traffic operating condition - lack of traffic control devices
- drivers faults
- mechanical failure

**Traffic engineering tools**



**Physical measures**

**To control vehicular movements**

- road signals/signs/markings
- road divider/channelisation/island
- exclusive turning lane - flaring/widening of intersection
- slip road
- bus lay-by
- speed breakers
- segregated bus lane
- grade separation etc.

**To control standing vehicles**

- on/off street parking
- off street load/unloading for freight vehicles
- terminals etc.

**To control pedestrian movements**

- guard rail/median/pedestrian barriers
- side walk
- cross walk
  - un-signalized – Zebra crossing
  - signalized (time separated/sharing)
  - grade separated (space separated)
    - underpass
    - overpass

**Regulatory measures**

- banning right turn
- one-way operation
- junction clear-way
- speed control
- parking control
- access control
- road pricing etc.

## ROAD-TRAFFIC SYSTEM

### Introduction

The Road-Traffic system is a complex interaction among four components -

- Road
- Vehicles
- Road users
- Environment

### ROAD

It comprises as follows:

- Links
- Intersections
- Footpath/Shoulder
- Fly-over/Tunnel
- Foot over/under bridge
- Bus lay-by/Terminal areas
- Parking areas
- Loading/unloading areas
- Channel/islands/medians etc.
- Road bridges/culverts
- Traffic control devices

### Roadway types

A. Geographical area or location-wise

- Rural Road
- Urban Road

B. Function-wise

- Rural Road
  - National Highways
  - Regional Highways
  - Feeder Road A
  - Feeder Road B
- Urban Road
  - Primary/Main/Arterial Road
  - Secondary Road
  - Local Road

C. Standard-wise

- Full access control, Expressway/Motorway, with grade separated junctions
- Partial/No access control with at-grade intersection

D. Usage-wise

- Commuter road
- All purpose road
- By-pass
- Distributor/Ring road
- Feeder/Collector road
- Slip/access road
- Service road
- Frontage road

E. Operation-wise

- Single Carriageway/Undivided Road
- Dual Carriageway/Divided Road
- Two way
- One-way
- Lane/non-lane based

F. Investment-wise

- Public Road - Free
- Private: Build, Operate and Transfer (BOT) – tolled road

## Type of Junctions

### Basic form-wise

- At-grade
  - Cross
  - Skewed
  - Tee
  - Wye
  - Staggered
  - roundabout
- Grade separated interchange
  - trumpet
  - diamond
  - clover-leaf
  - roundabout/rotary

### Operation-wise

- Uncontrolled
- Controlled
  - Priority Controlled
  - Signalized

## VEHICLES

### Types of Vehicle

- Propulsion force wise
  - Motorized
    - Truck
      - Large
        - Single
        - Articulated
          - Trailer
          - Semi-trailer
      - Small
      - Mini/Pickup
    - Bus
      - Large
        - Single-deck
        - Double-deck
      - Mini
      - Micro
    - Car/Jeep etc.
    - Motorcycles
    - Other non-conventional
  - Non-motorized
    - Rickshaw
    - Bicycle
    - Other non-conventional (animal driven)
- Service/usage-wise
  - Private
  - Public
    - Mass transit – bus, tempo, tram, trolley buses, Light rail transit (LRT) etc.: use shared carriageway
    - Rapid transit – underground rail/metro/tube, elevated guide-way, LRT system etc.: use segregated carriageway
    - Personalized transit
      - Para-transit - rickshaw, auto rickshaw
      - Taxi service
      - Rent-a-Car/hired car
- Carrier-wise
  - Passenger vehicles
  - Freight vehicles

- Fuel/energy type wise
  - Petrol/Diesel
  - Compressed Natural Gas
  - Electricity
  - Solar
  - Fuel cell
  - Hybrid
- Driving force wise
  - Two-wheel (2WD)
  - Four-wheel drive (4WD)

#### **Types of Vehicle Maneuver**

- crossing
- merging
- diverging
- lane changing
- overtaking
- turning
- weaving

#### **ROAD USERS**

Comprises:

- Drivers
- Passengers
- Pedestrians

#### **ROADWAY ENVIRONMENT**

Include elements which influence traffic operating condition:

- Roadway geometric conditions – standard of road, surface condition, horizontal & vertical alignment
- Traffic control & regulation
- Road side management – pedestrian/parking/access control
- Lighting condition

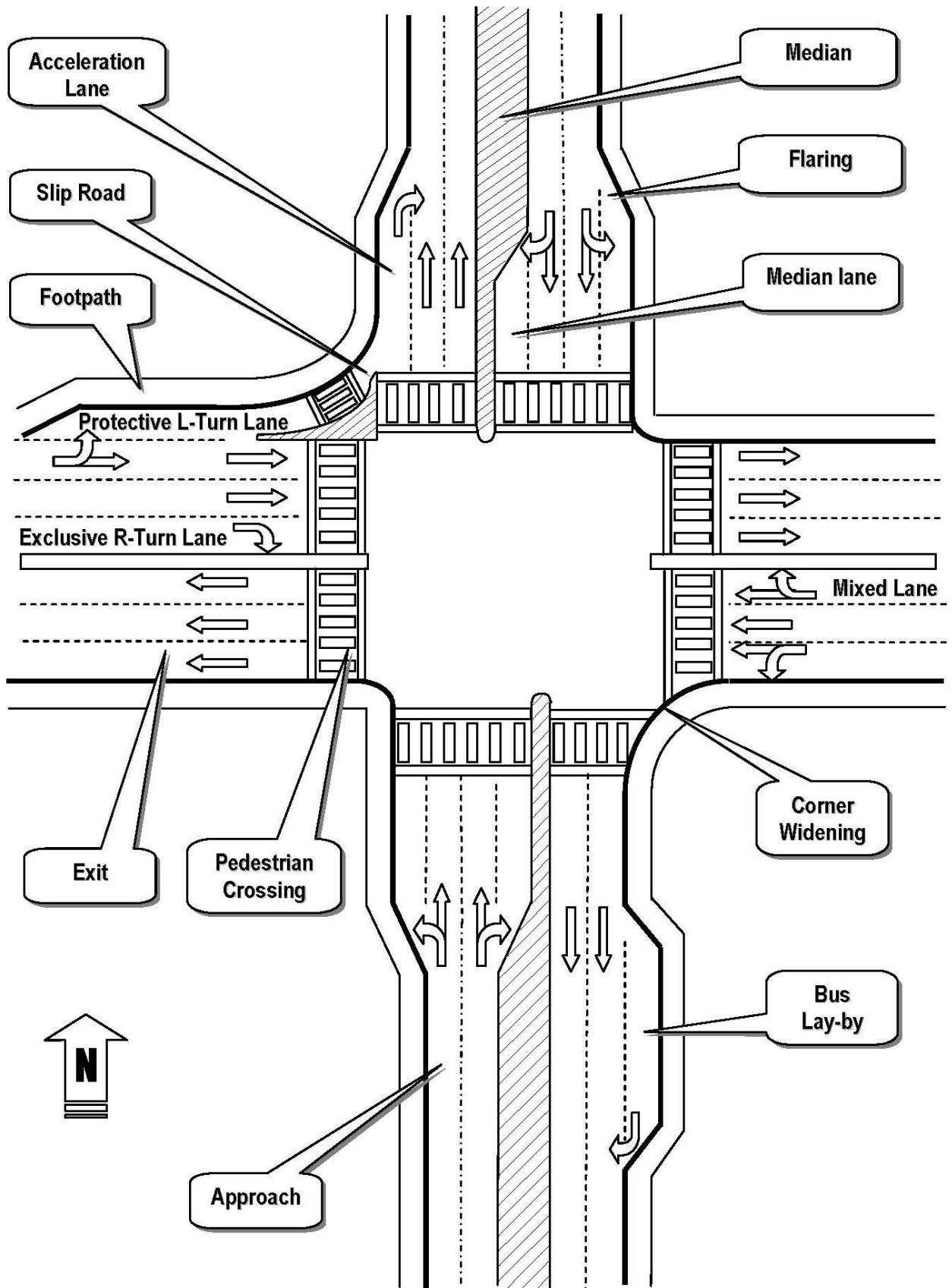

## ELEMENTS OF A TYPICAL IMPORTANT & BUSY JUNCTION

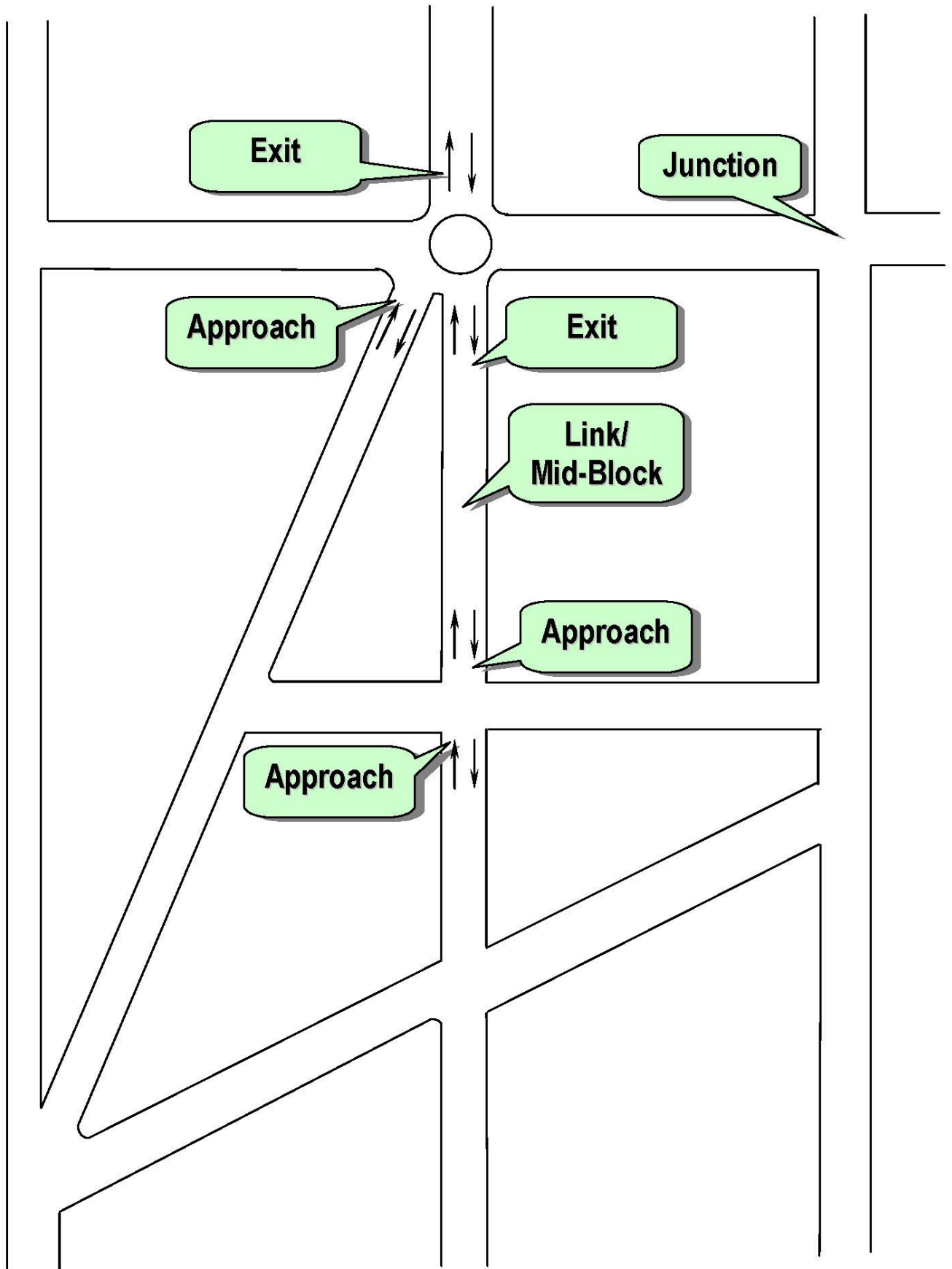

## ILL PLANNED ROAD NETWORK

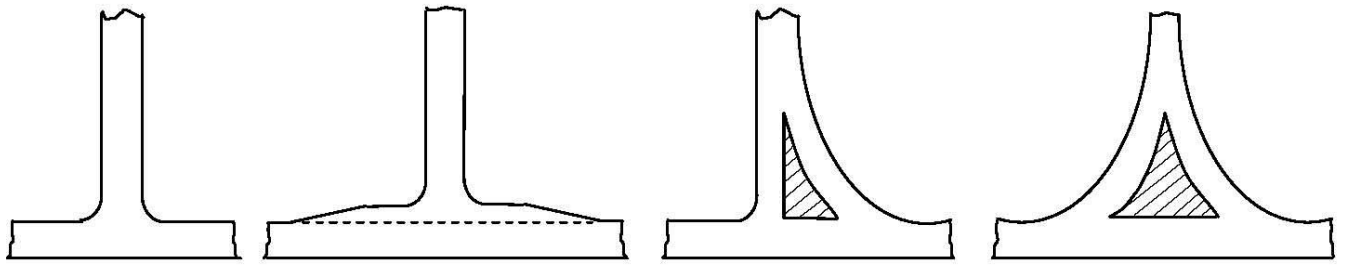

**Unchannelized T**

**Flared T**

**Channelized T**

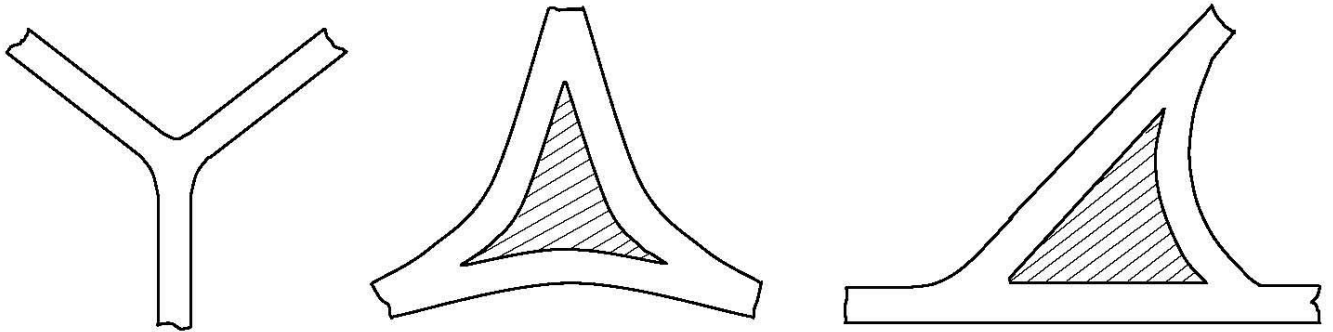

**Unchannelized Y**

**Channelized Y**

### 3 - LEG INTERSECTIONS

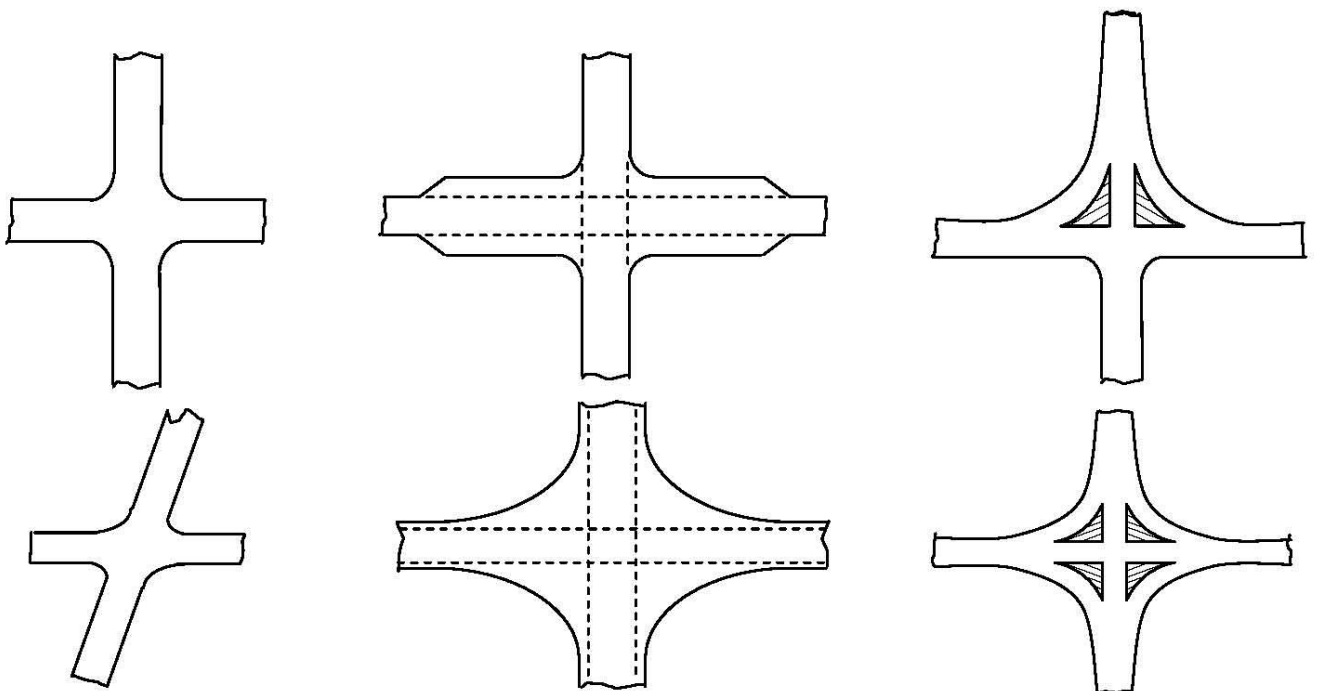

**Unchannelized Cross**

**Flared Cross**

**Channelized Cross**

### 4 - LEG INTERSECTIONS

**Left Staggered**

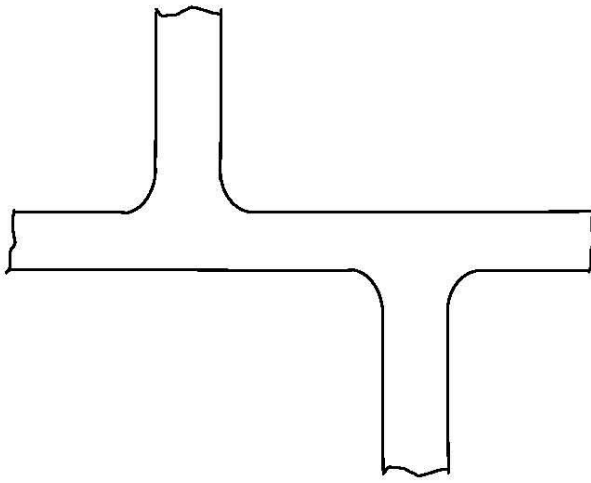

**Right Staggered**

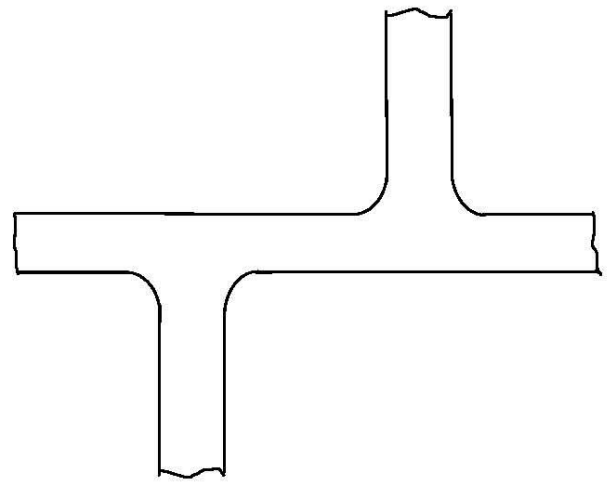

**STAGGERED INTERSECTIONS**

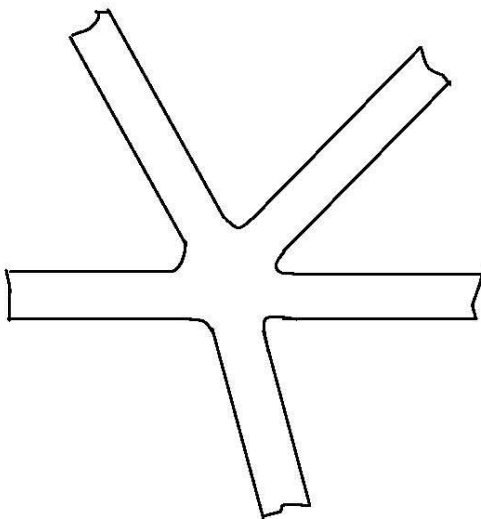

**Multileg**

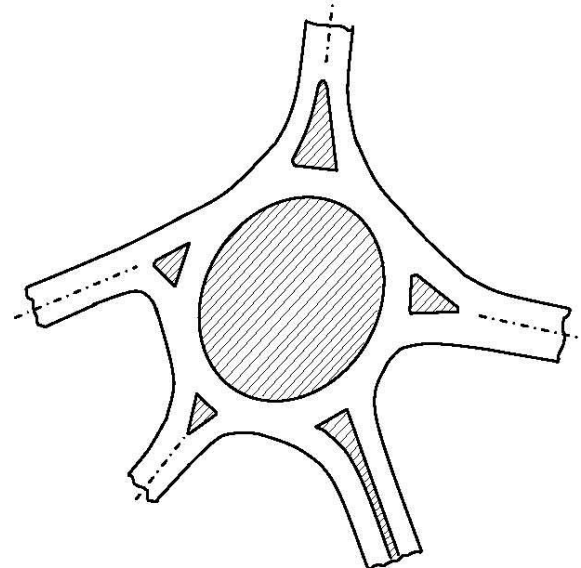

**Rotary/Roundabout**

**MULTI - LEG INTERSECTIONS**

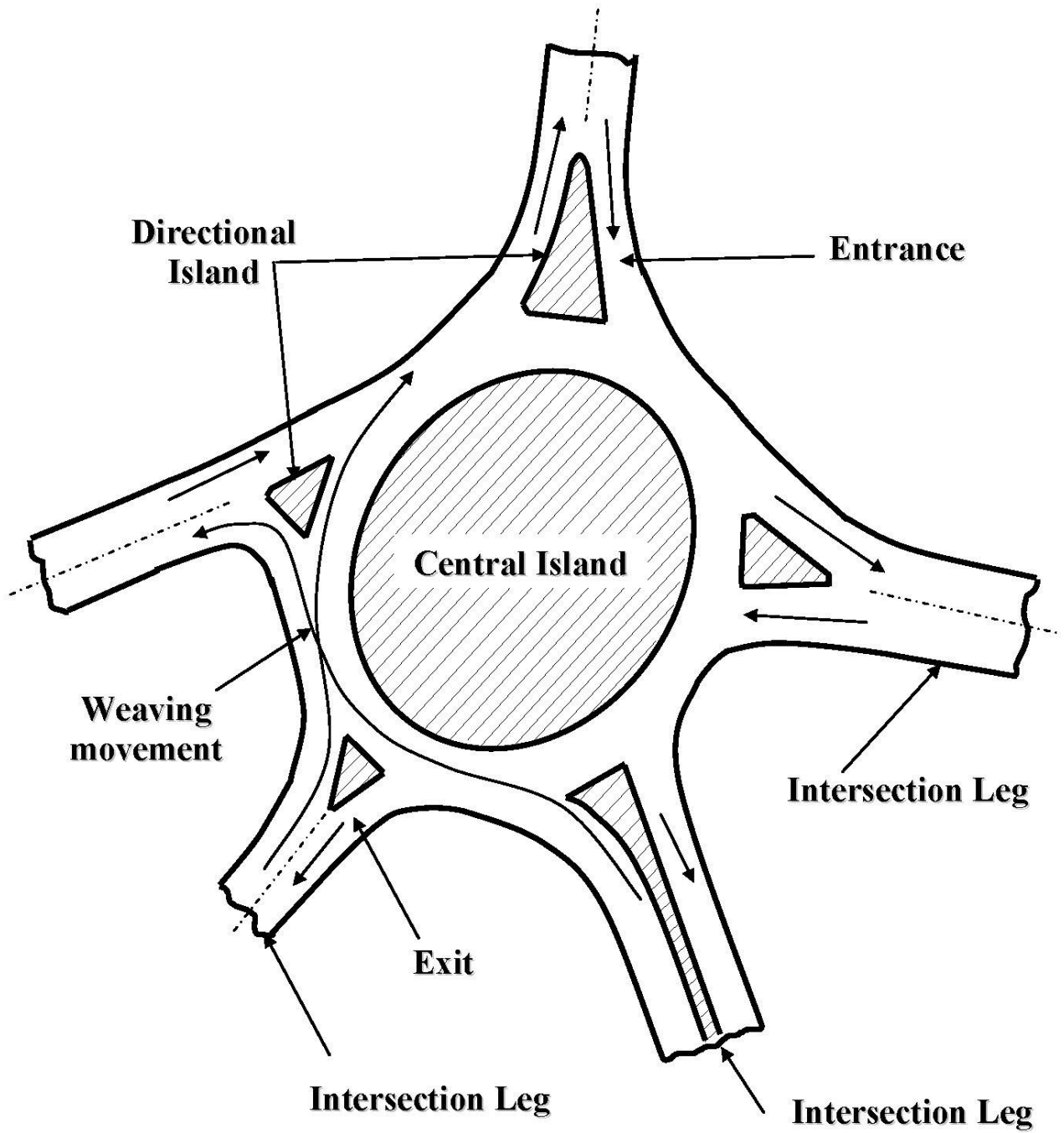

## ROTARY/ROUNDAABOUT

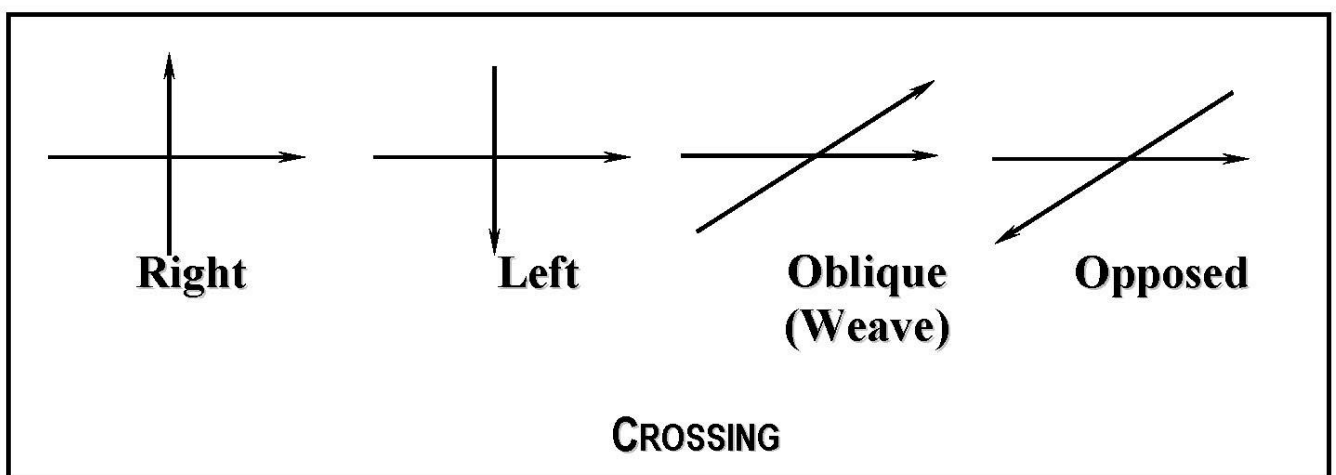
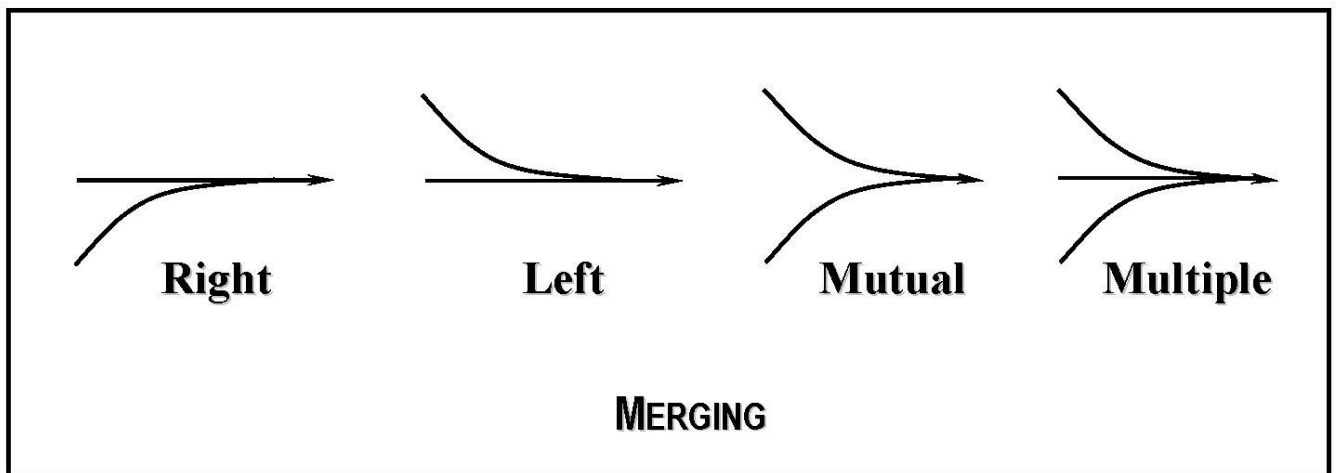
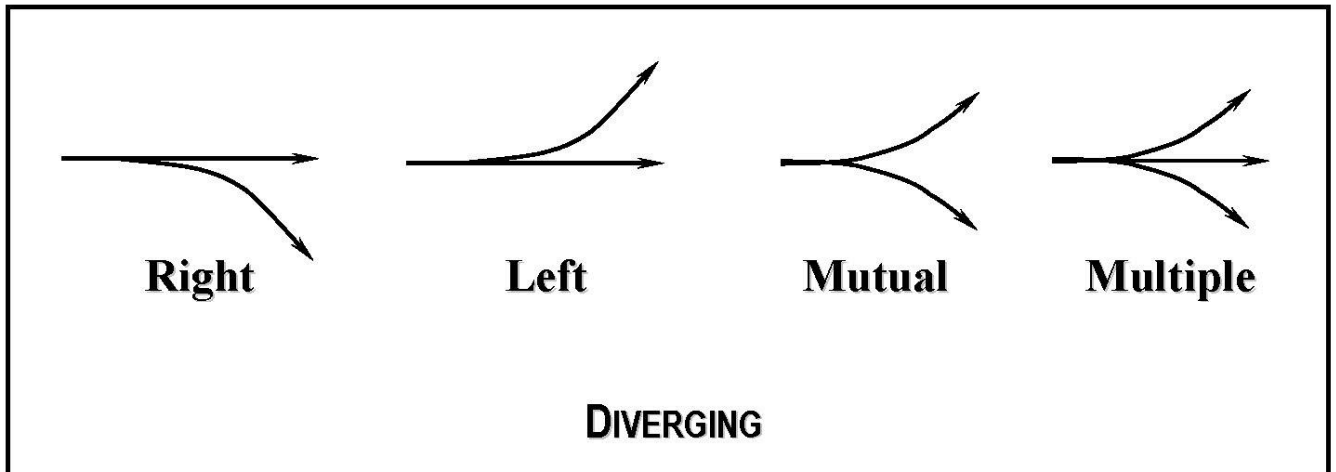

## DIFFERENT VEHICULAR MANEUVERS AT INTERSECTIONS

## TRAFFIC CHARACTERISTICS

### General

- Study of traffic characteristics include
  - Vehicular characteristics
  - Road User's Characteristics
- Traffic engineer has to design and operate the traffic facilities that will be used by pedestrian, cyclists and motorists. As such a proper understanding of the behavior of the road user and the vehicle characteristics is necessary for this purpose.
- Vehicular and traffic characteristics affect highway planning, design, improvement or operational aspects of traffic engineering. As such design/improvement/control and regulations of roadway features should be compatible with its users for safe and efficient movements.

### Vehicular Characteristics

- It would be impracticable and uneconomical if roadway is designed to accommodate all types of vehicles. Generally, roadway is design for design vehicle that will enjoy safe driving and full level of service (LOS) – whereas, extreme users will get lower safety and LOS.
- A vehicle that represents the design standards is termed as **design vehicle**. Whose properties are fixed based on statistical analysis of population – 50<sup>th</sup> percentile (mean) value; 85<sup>th</sup> percentile or maximum value etc. depending on the purpose of use i.e. fixing turning path, parking lot design etc. Characteristics of design vehicle actually fix all the dimensions of the road.
- The various vehicular characteristics affecting the road design can be classified as
  - Static characteristics and
  - Dynamic characteristics.

### Static/physical Characteristics

- **Axle load** - Weight of vehicle affects
  - structural design of
    - pavement – number of layers, thickness of each layer, material requirements etc.
    - bridge/fly-over/grade separator
  - fixing gradient of roads in rolling terrain, ramp, bridge approach etc. and it is depend on vehicles' weight/power ratio
- **Width** - Width of Vehicle affects
  - lane width
  - shoulder width
  - width of parking bay
- **Length** - Length of vehicle affects
  - design of horizontal alignment i.e. determination of extra widening and minimum turning radius
  - passing sight distance
  - parking facility (bay & isle)
  - roadway capacity
- **Height** - Height of vehicle affects
  - clearance to be provided under the structures e.g. under-bridge, over-bridge, sign-post gantry, electric services lines, etc.

### Dynamic Characteristics

- **Speed** - It is such a factor that controls most of the geometric standards of the highway viz.
  - horizontal and vertical alignment design
  - limiting radius
  - grade
  - length of transition curve
  - super-elevation
  - stopping/overtaking sight distance
  - width of pavement on straight and curves
  - capacity/LOS
  - intersection design and control (fixing amber period, co-ordinated signal design, stop sign, etc. )
  - skid resistance
- **Acceleration/Deceleration (braking) performance**
  - acceleration capability influences junction capacity, safe passing distance etc.
  - maximum deceleration rate is required to know safe stopping distance

## ROAD USER'S CHARACTERISTICS

### General

- Road users e.g. pedestrians and drivers are most complex and least understood element of roadway system
- As road users are a major part of the system, human limitations and behavior must be understood and taken into account in all traffic engineering and design matters
- It has been found that over 90 per cent of all highway accidents are due to errors of judgment
- As such it is of paramount importance for a traffic engineer to study the factors which directly or indirectly influence the manner and rate at which errors occur
- The behavior of a road user depends upon the factor like education, environment and training
- Driver's driving education/road sense can be improved by strict licensing/road safety education policy
- As for pedestrians there is no scope for formal education and they are most exposed vulnerable group comprising largest road users group especially within urban area – they need protection by law. Priority on right-of-way is given to pedestrian. Therefore, it is the driver's responsibility for safety of pedestrian and as such his behavior in this regard is very important.

### Driver Characteristics

Drivers' characteristics are involved in

- accommodating roadway environment during driving or adopting safe speed according to roadway environment:
  - curved/straight
  - poor surface condition
  - lane width
  - poor access controlled
  - density of traffic
  - approaching towards priority junction
  - negotiating bottlenecks: intersections, speed breakers, bridges, pedestrian crossing, side roads,
  - day/night, weather condition: sunny/foggy/rainy
- gap acceptance
- lane change/overtaking
- crossing junction at the end of green period (stopping/not stopping)
- keeping headway with the leader
- roadway sign design (letter height/size and placement – color perception, depth of vision, speed)
- street lighting design (fixing level of illumination – depending on drivers' ability to see)
- roadway markings design (color and intensity of retro-reflective markings)
- licensing control

### Factors affecting the road user characteristics

The factors which affects behavior of road users are:

- Physical factors** - this includes
  - eye-sight/vision
  - hearing power
  - other defects/disabilities
  - fatigue, alcohol or drugs, illness etc. are the temporary physical characteristics which affect reaction time, judgment time, alertness
- Mental factors** - this includes
  - intelligence
  - education, skill, knowledge
  - experience/training of the drivers
- Psychological factors** - this includes
  - impatience
  - attentiveness
  - ability to follow regulation and
  - maturity

### Reaction Time

The time interval between seeing, hearing, or feeling, and the starting to do something in response to the stimulus of a traffic or highway situation is called "reaction time". Ideally, this response of the driver requires time for the following psychological process:

- Perception** - which involves seeing the stimuli along with other perceived objects
- Identification or intellect** - which involves the identification and understanding of the stimuli

- **Emotion or judgment** - which involves the decision making process, in which a determination is made as to the proper course of action (to stop, pass, merge, cross, move laterally, or blow horn etc.)
- **Volition or reaction** - which involves the execution of the decision

However, this sequence does not typically occur in emergency/ surprised situations. Rather, perception of a dangerous situation is frequently followed by emotional response without the intervening stage of intellection. As this emotional response is very quick and sudden almost reflex-like, often provides undesirable/disorganized response in the face of a hazardous situation.

#### PIEV

- The total time required to perceive and complete a reaction to a stimulus is the sum of the times necessary for perception, identification, emotion, and violation. This total reaction time is often referred to as the PIEV time.
- The time required for reacting properly and safely (after making proper evaluation of all pertaining factors) can vary from about 0.5 sec for simple situations to as much as 3 or 4 sec for more complex situations.
- PIEV time is required to determine
  - safe-stopping sight distance
  - safe approach speeds at intersection
  - amber/clearance time interval for traffic signals
- PIEV time increases with
  - complexity of situation
  - gravity of the event (people generally react quicker to very strong stimuli than to weak ones)
  - vehicle speed
  - drivers' age
  - physical deficiencies
  - mental/emotional state/psychological conditions – which temporary distract attention/ concentration/alertness of driving or make less responsive to stimuli:
- Besides above factors PIEV time depends on
  - speed of vehicle
  - even location of roads etc. – within built-up drivers remain extra vigilant/alert and always expect surprise situation, in contrast driving in open rural highway is very relaxed and less attentive
- PIEV design value
  - design value is usually based upon the normal range of road users (85th percentile group) and not upon the abnormal. (design would be uneconomical if extreme values are considered)
  - brake reaction time recommended by AASHTO for (perception time = 1.5 sec)
    - rural area – 1.0 sec (PIEV = 2.5 sec)
    - urban area - 0.75 or 1.0 sec (PIEV = 2.25 – 2.5 sec)

### Pedestrian Characteristics

#### General

- important especially in urban areas
- pedestrian actions are less predictable than those of drivers – as many pedestrians consider themselves “outside the law” in traffic matters
- they are hard to enforce
- pedestrians are more often disobey traffic control devices than are drivers

#### Crossing Characteristics

- in generally pedestrians tends to walk in a path that represents the shortest distance or most convenient route between two points
- they often cross at mid-block instead of using crosswalks
- pedestrians also have a basic resistance to change grades when crossing roadways
- they don't voluntarily make use of special pedestrian facilities such as underpasses or overpasses

#### References

- Institute of Traffic Engineers*, “Traffic Engineering Handbook”, Third Edition, 1965.  
*Institute of Traffic Engineers*, “Transportation and Traffic Engineering Handbook”, Second Edition.  
*Matson, M.T. and Hurd, W.F.*, “Traffic Engineering”, McGraw-Hill, 1955.  
*Kadiyali, L.R.*, “Traffic Engineering and Transport Planning”, Second Edition, 1983.

## TRAFFIC SURVEYS/STUDIES

### Need for Traffic Survey

Traffic engineers and planners need information about traffic for a variety of purposes in the course of their work of managing the road and traffic system viz.

- Planning and designing traffic facilities, including the selection of geometric standards, economic analysis, and the determination of priorities
- Determining the need for traffic control devices such as signs, traffic signals, pavement markings, school & pedestrian crossings
- Studying the effectiveness of introduced schemes
- Diagnosing given situations & finding appropriate solutions
- Forecasting the effects of projected strategies
- Calibrating and validating traffic models.

Traffic surveys are the means of obtaining information for these purposes. Specifically, the main purposes of traffic surveys may be summarized as follows:

- Traffic Monitoring
- Traffic Control and Management
- Traffic Enforcement
- Traffic Forecasting
- Model Calibration and Validation

### Traffic Studies includes

- Inventories of road-traffic physical features
- Traffic stream characteristics - volume, speeds, density, occupancy studies etc.
- Capacity studies of streets and intersections
- System usage studies
  - Travel time and delay
  - Origins and destinations
- Travel demand - Home interview survey
- Studies of road users cost
  - Value of travel time (VOT)
  - Vehicle operating cost (VOC)
- Parking supply & demand studies
- Axle load survey
- Mass transit performance and usage studies
- Traffic accident studies
- Environmental impact studies of transport (noise, air pollution etc.)

### Methods of Data Collection and Analysis

Methods of collection and analysis of traffic data are changing rapidly with advancement of auto data collection system. New equipment is enabling wider ranges of data for longer duration to be collected more reliably and at lower cost than was possible with earlier forms of equipment. At the same time, advancement of statistical techniques and relevant user friendly software are enabling these data to be interpreted in new ways.

### Data may be acquired:

- Directly using
  - Manual method
  - Automatic recording devices
  - Interviews/Questionnaire survey
- Indirectly using
  - Video recording
  - Post card survey

Much of the data collected is used to define the limiting parameters and modal values. Since the amount of data involved is large statistical methods are widely used to reduce the task.

### **Bangladesh**

- ❑ Lack of qualified traffic engineers
- ❑ Traffic engineering profession has not been recognized at the institutional level
- ❑ Little importance of data/monitoring system
- ❑ No systematic collection of comprehensive data
- ❑ Lack of data based planning and program implementation - many improvements done without benefit/cost analysis (over-passes)

### **References**

1. NAASRA, Guide to traffic engineering practice, Sydney, 1976.

# TRAFFIC VOLUME STUDY

## Introduction

Volume data are needed in research, planning, designing and regulation phases of traffic engineering and are also used in establishing priorities and schedules of traffic improvements. The traffic engineer must acquire general knowledge of traffic volume characteristics in order to measure and understand the magnitudes, composition, and time and route distributions of volume for each area under his jurisdiction.

## Definitions

### Volume/flow

The total number of vehicles that pass over a given point or section of a lane or roadway during a given time interval. It may be expressed in terms of annual, daily, hourly, or sub-hourly periods; usually in vph or vpd. Volume is an actual number of vehicles observed or predicted to passing a point during a given interval.

### Rate of flow

The equivalent hourly rate at which vehicles pass over a given point or section of a lane or roadway during a given time interval less than 1 hr. usually 15 min. It represents the number of vehicles passing during a time interval less than 1 hr, but expressed as an equivalent hourly rate.

### Average Daily Traffic (ADT)

The volume during a given time period (in the whole days greater than one day but less than one year) divided by the number of days in that time period and expressed in terms of veh/day or vpd.

### Average Annual Daily Traffic (AADT)

It is the total yearly volume divided by the number of days in a year and expressed in terms of veh/day or vpd.

### Design Hourly Volume

It is the economic hourly flow of future year, which is used for designing geometric features of roadway. It is chosen in such a way that during the design period it should not be exceeded too often or too much.

## Scope Of Traffic Volume Studies

The traffic volume count study is carried out to get following useful information:

- magnitudes, classifications and the time & directional split of vehicular flows
- proportions of vehicles in the traffic stream
- hourly, daily, yearly and seasonal variations of vehicular flows
- flow fluctuation on different approaches at a junction or different parts of a road network system

## Objectives

The **purposes** for carrying out traffic volume count are as follows:

### Design purposes

- structural and geometric design of pavements, bridge, and other highway facilities
- intersection design including minimum turning path, channelization, flaring, traffic control devices viz. traffic signs, markings, signals based on approach volume and turning proportions
- pedestrian volume study is useful for designing side walks, pedestrian crossing etc.

### Improvement purposes

- to allocate limited maintenance budget rationally it is important to know the traffic volume carried by a particular roadway section in order to decide the importance of the road and fixing its relative priority
- in order to improve the roadway operating condition it is important to know the traffic volume
  - to examine the existing operating/service condition of a roadway section
  - to check the need for (warrant) traffic control devices
  - to determine the type of improvement measure need to be taken
  - to measure the effectiveness of a traffic control measure

### Planning purposes

- accurate information on the amount of traffic on the roads is vital for the planning of both road maintenance and improvement policies
- traffic volume network analysis helps in deciding/planning if there is need for
  - improvement or
  - expansion in terms of constructing missing links, by-pass, alternative road etc.

### Dynamic Traffic Management Purposes

- Up to date and continuous flow/congestion information is essential for optimizing
  - traffic signal design and thereby improving junction performance
  - network productivity by providing information to the road users

### Other Purposes

- estimation of highway use
- measurement of current demand of a facility
- estimation of trends
- economic feasibility evaluation
- computation of accident rates - accidents/100m vehicle-miles

### Types of Flow/Volume

<b>Interrupted flow</b>	Flow at stopped and go situation
<b>Uninterrupted flow</b>	When the flow is smooth
<b>Saturation flow</b>	The maximum hourly rate of an approach at a signalized junction
<b>Service flow rate</b>	The maximum hourly rate of a roadway section during a given period under prevailing roadway condition
<b>Free flow</b>	When drivers face no restriction in driving and can maintain their desired speeds
<b>Forced flow</b>	When lane changing opportunity decreases with increasing traffic volume and drivers are forced to follow slow leaders
<b>Stable/steady flow</b>	When demand is well below the roadway capacity and the average rate of flow remains almost constant with time
<b>Unstable flow</b>	When demand is at or near or exceed the roadway capacity and the average rate of flow fluctuates largely with time
<b>Peak flow</b>	Flow at peak periods
<b>Off-peak flow</b>	Flow at off peak/lean periods
<b>Contra flow</b>	- for repair works: an arrangement on a large road by which traffic going in both directions uses only one side of the road - for bus priority: an special arrangement on one-way street by which only bus is allowed to go in opposite direction
<b>Tidal flow</b> 	When traffic flows in both direction exhibit unbalanced characteristics at peak periods viz. morning rush at in-bound lanes due to commuter traffic and in the evening the same is true for the out-bound lanes.
<b>Induced flow</b>	Flow that is generated because of new or improved roadway facility

### Methods of Counting

- Manual Counting Method**– following are the most common forms of manual counting methods:

**Direct Method** - data is collected by using hand tally and manual counters/enumerators

#### Advantages

- besides traffic volume, vehicle classification and turning proportions can be obtained
- data can be use immediately after collection

#### Disadvantages

- not practicable for long duration count and when flow is high
- counts become error prone specially when volume is high
- no scope for cross check
- weather susceptible

**Indirect Method** - data is collected using video camera

**Advantages**

- besides traffic volume several traffic parameters can be obtain from the same recorded film
- scope for cross check ensures quality data
- it is applicable even if volume is high or road width is very large
- suitable for non-lane based traffic operation

**Disadvantages**

- required suitable elevated place for filming operation
- data can not be use immediately after collection - required manual transcription of recorded film which is very tedious and time consuming
- not suitable for long duration counts
- susceptible to intensity of light

**Automatic Counting Method** – following are the most common forms of auto counting techniques:

**Contact system** - viz tube, loop, piezo detectors/sensors

- based on **pneumatic** action
- based on **mechanical** actuation
- based on **magnetic** actuation
- based on **piezo-electric** actuation

**Contact-less system**

- based on **electrical/optical** actuation by interruption of a light beam falling on a photoelectric cell as vehicle passes
- radar devices** based on Doppler principle (phase shift of the reflected energy)
  - ultra sound** imaging
  - infra red** imaging (sensing heat-radiation)
- based on two-way **micro-wave** communication between vehicle (Electronic Tag/Smart Card) & counting station
- based on **CCTV/video image processing** machine vision technique (pattern recognition)

**Advantages**

- suitable for long duration/continuous counts
- useful for permanent counting station
- able to get data in usable format (no need of data entry) & on line data collection facility
- less expensive
- weather friendly
- no street surface dug up (unlike loop) is required for contact-less methods; they are installed at or above the road surface level

**Disadvantages**

- most of the methods required strict lane discipline
- difficult to detect non-motorized vehicles specially using the contact based detectors
- can classify only few distinct classes of vehicle (with increase in vehicle classes calibration/auto-recognition process become more error prone)
- data is not as accurate as that from manual method (required comprehensive & routine calibration)
- usually do not provide directional count (as detection become difficult)
- installation and maintenance costs are high; needed over-head gantry or road side tower

**Counting Periods**

The count can be for any duration and depends on the objective of the study or the information needed. Generally:

- Short duration count at peak periods is conducted for operational studies including those for roadway improvement & maintenance and traffic control & management
- Long duration count is conducted for transport planning and design

**Factors Affecting Traffic Volumes**

**Composition of Traffic Volumes**

- Different types of vehicle within the traffic stream makes it difficult to express flow in terms of vehicle. Flow value is calculated by converting all the vehicles to a common type usually the passenger 'car'.



- PCE** – It is the method of expressing various types of vehicles having different characteristics in a common equivalent unit. It is needed to remove the effects of traffic composition from flow calculation. One car is

considered as one unit. In respect of its road occupancy and operational requirements each type of vehicle is equivalent to a number of passenger cars and this is called the **Passenger Car Equivalent/Unit (PCE/PCU)**. PCE is directly related to capacity value.

- **Periodic Variation in Traffic Volumes**
  - Hourly flow rates fluctuate throughout the day and night
  - Daily volume vary considerably throughout the week
  - Traffic flow also fluctuate with seasons

#### **Presentation of Traffic Data**

- **For network analysis** - In the form of **traffic flow maps** along the routes surveyed. Which shows clearly the magnitude of traffic volume (ADT) for any given location or relative flow level (or flow distribution by routes) within a network. This type of presentation is important for planning, design, traffic management & regulation, and maintenance purposes.
- **For design/regulations/improvement of intersection** - In the form of **flow diagrams/chart** showing hourly volume along with directional split and in the form of **flow fluctuation** showing the changes of flow variations with time. Useful for junction improvement, demand-responsive signal design, banning right turn etc.)
- **For planning future extensions & design of new road** - In the form of **trend chart** showing volume trends over period of years and in the form of **annual hourly flow variation chart** in order to calculate design hourly volume

#### **References**

**Institute of Traffic Engineers**, "Transportation and Traffic Engineering Handbook", Second Edition.

**O'Flaherty, C.A.**, "Highways and Traffic", Volume 1, Second Edition, 1983.

**Transportation Research Board**, "Highway Capacity Manual", Special Report 209, Third Edition, 1994.

## Traffic Counting Summary Sheet

(Directional Daily Traffic Volume)

Location: East Toll Plaza

Direction: E to W

Day: Friday

Date: 24-May-02

Hours	L. Bus	M. Truck	L. Vehicle	S. Bus	S. Truck	M. Cycle	L. Truck	Total
	LB	MT	LV	SB	ST	MC	LT	
6 - 7	8	69	7	2	2	2	0	89
7 - 8	10	57	13	1	1	3	1	85
8 - 9	20	55	23	1	2	6	1	108
9 - 10	35	43	30	2	1	8	1	120
10-11	53	33	35	1	1	11	0	133
11-12	78	27	47	2	1	12	0	168
12-13	95	39	58	4	2	13	0	210
13-14	71	35	59	3	2	12	0	182
14-15	51	33	57	2	1	13	0	158
15-16	45	33	60	3	1	15	0	158
16-17	38	40	62	3	1	20	0	165
17-18	33	45	49	3	1	17	0	148
18-19	43	54	41	3	2	9	0	151
19-20	33	60	32	1	2	4	0	132
20-21	29	77	27	0	2	3	0	138
21-22	34	88	18	1	1	1	0	143
22-23	45	96	13	1	1	2	0	160
23-24	48	98	11	0	2	0	0	159
24 - 1	58	78	9	1	2	0	0	148
1 - 2	71	78	9	2	1	0	0	160
2 - 3	35	77	7	0	2	0	0	122
3 - 4	13	66	6	0	1	0	0	86
4 - 5	6	53	6	0	1	0	0	66
5 - 6	6	47	3	0	1	0	0	57
Total	958	1382	681	37	31	152	5	3245

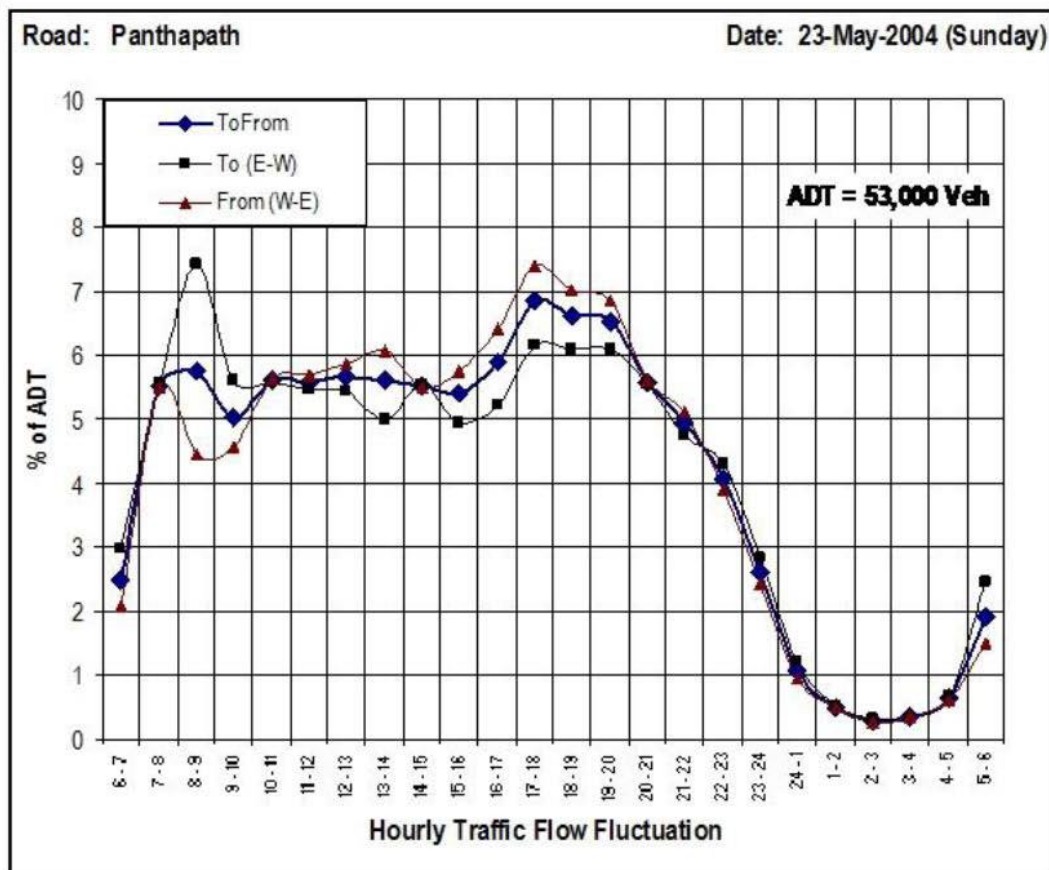
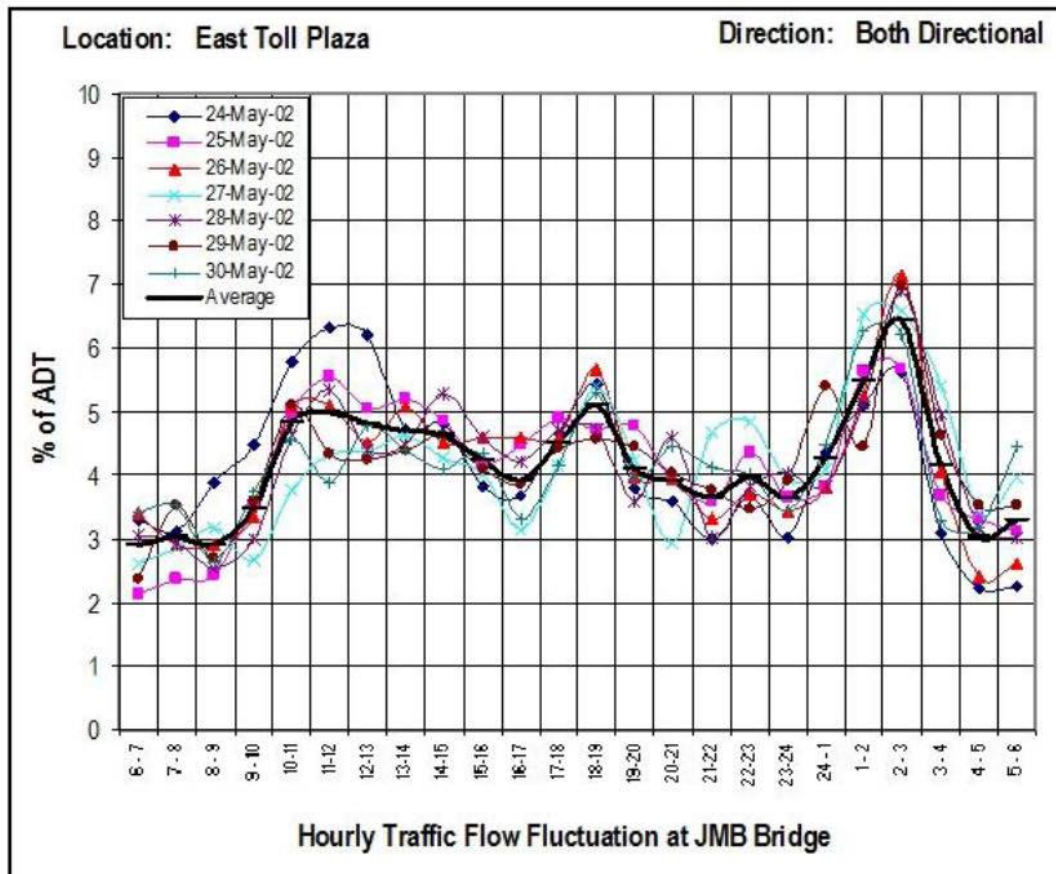

**FLOW DIAGRAM**  
**GRAPHIC SUMMARY OF VEHICLE MOVEMENTS**

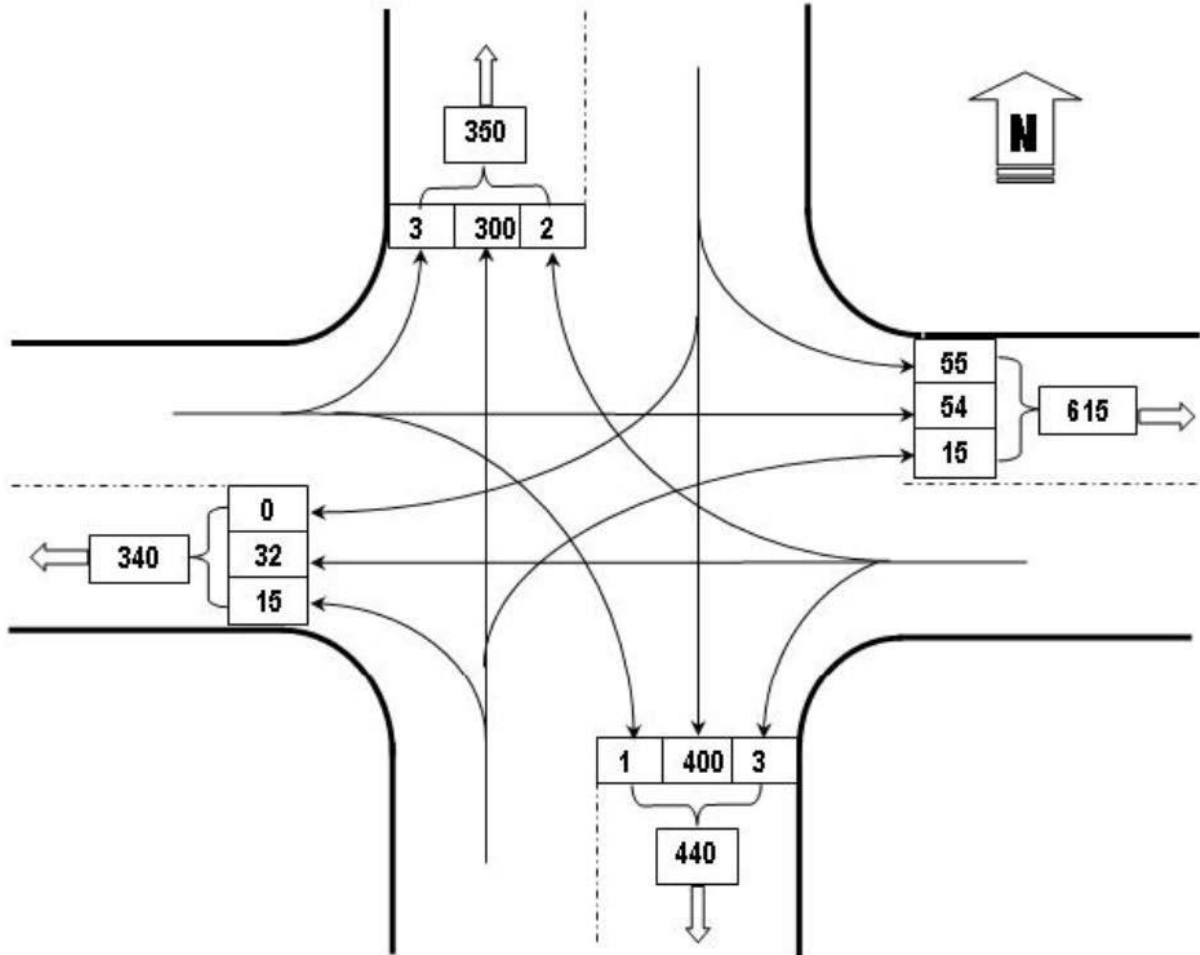

**Notes: All Traffic Movements in PCU/hr**  
**Counting Period: 0830 to 0903 AM**

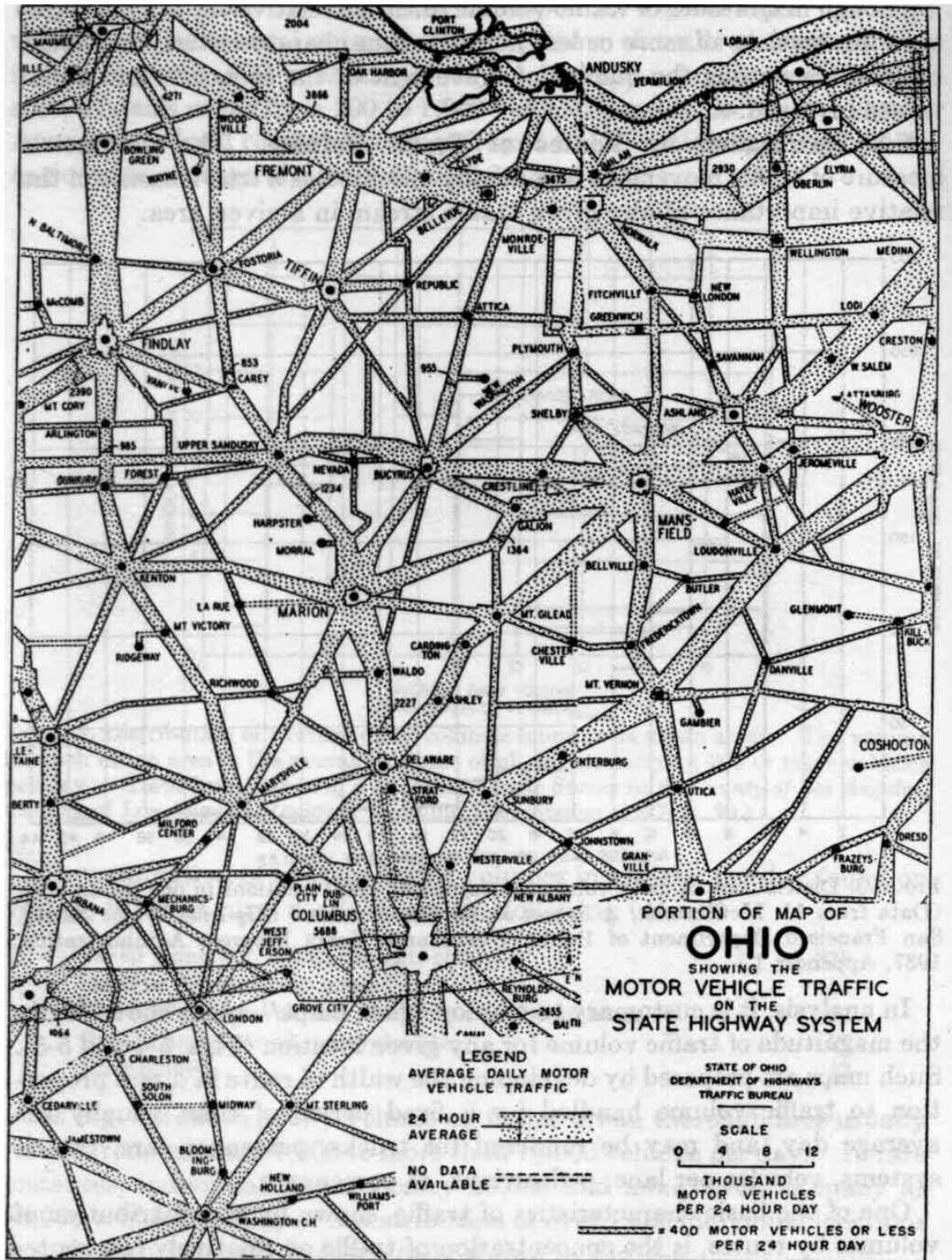
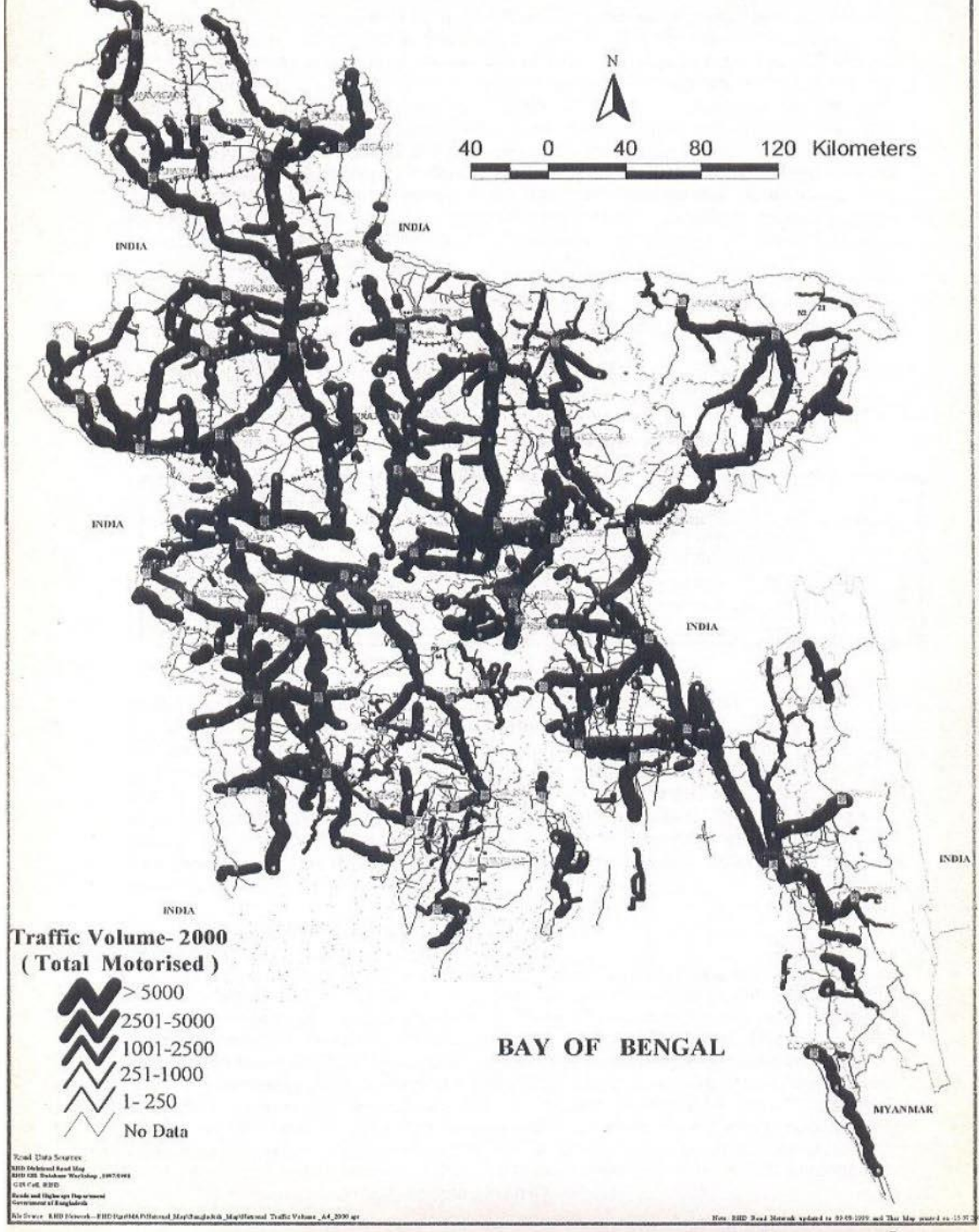
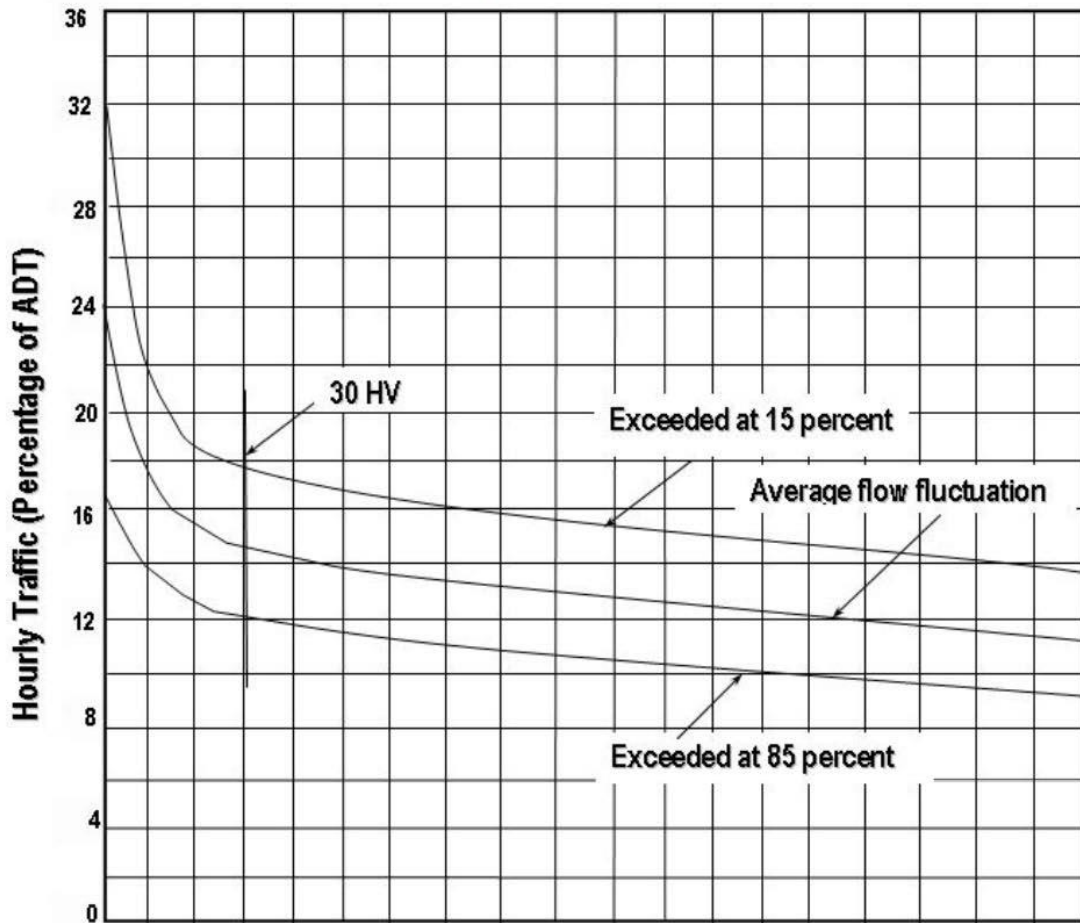

FIG. 5-4. State traffic flow map.

# RHD Road Traffic Volume in Bangladesh - 2000



**ANNUAL HOURLY FLOW VARIATION CHART  
(FOR TYPICAL RURAL HIGHWAY)**



**No. Of Hours In One Year With Hourly Volume Greater Than That Shown**

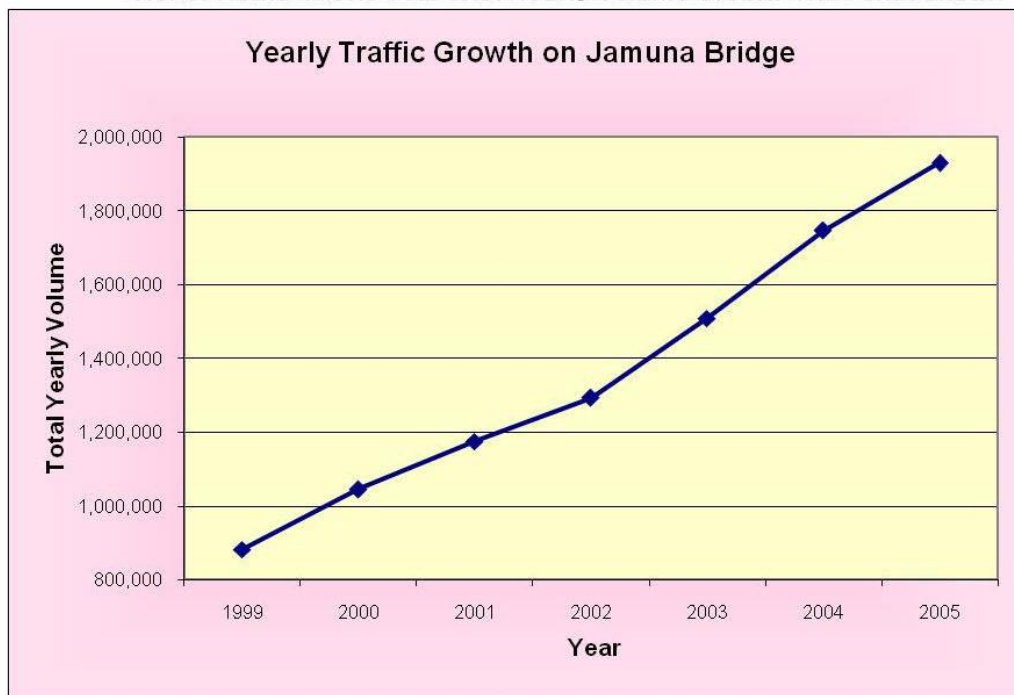



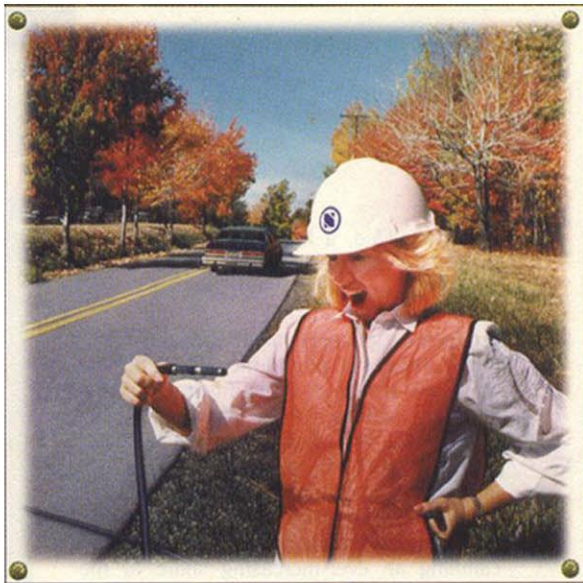
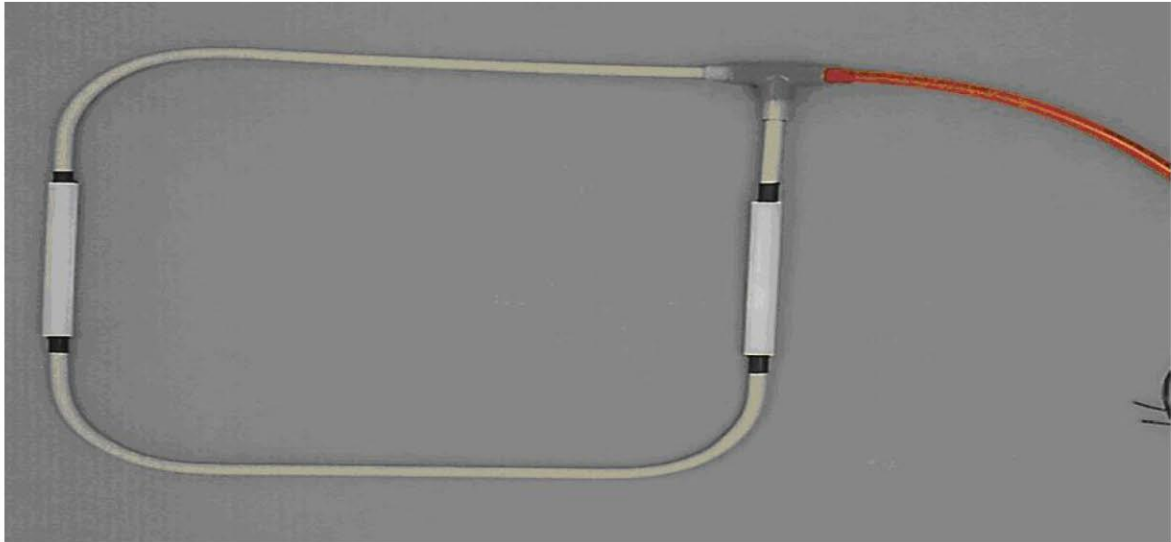

## Integrate Laser Systems

MDL's industrial laser sensors to accurately profile and classify vehicles

LaserAce® IM is an industrial laser sensor designed to be integrated into systems to output speed, height, vehicle count, classification or trigger cameras for optical character recognition (OCR) applications. Due to the laser beam being very narrow, precision measurement is made directly to vehicles without interference from other objects.

A diagram illustrating the laser sensor's application. A red car is shown on a road. Two vertical lines represent laser beams directed at the car. To the right, a blue box contains a black line graph showing the profile of the car, demonstrating how the sensor measures the vehicle's height and shape.

# HIGHLY ACCURATE

**The Hi-Star® Portable Traffic Counter and Classifier**  
*represents the latest technology in magnetic sensing for computing speed and classification.*

**FEATURES:**

- Totally Self-Contained - No External Sensors, Loops or Tubes!
- Rugged Die-Cast Aluminum Case
- Easy Installation and Removal
- Vehicle Magnetic Imaging Sensor Technology
- Full Alpha/Numeric Heading
- Presence, Occupancy and Volume
- 8-Bins of Length, 15-Bins of Speed
- Count Intervals: 1 Minute to 2 Hours
- Rechargeable NiMH Batteries
- Underwater/Underground Operation
- Protective Cover Keeps Unit Safe Under Heavy Traffic Conditions
- User-Friendly Highway Data Management (HDM) software

**Manage Intersections or a Single Lane...**

**...Then Download the Data into the Software!**  
*From the stored data, a number of valuable reports and graphs can be generated depicting all types of traffic related information.*

## detection & CLASSIFICATION

**1**

**2a**

**2b**

**3**

1: typical sun 'burn-out' experienced with visible-light camera technology; 2: typical sun image capture quality using the new IR camera technology, which works equally well with dark- (2a) and light-coloured (2b) plate backgrounds; 3: night-time image capture using the new IR cameras

## Estimate of ADT, AWT, AADT from Short Counts

### Ref. Traffic and Highway Engineering by Grabber, p 114.

If traffic data are collected continuously for a long period and presented for a number of consecutive days, weeks, months, years etc. then the repetitive nature of the variation will be observed, since the pattern of the hourly, weekly, monthly variations will be similar for all years, although the actual volumes may not necessary be the same.

There are two approaches for the estimation of ADT, AADT from short counts:

1. Factor approach - previously established expansion factors from continuous count are used.
2. Regression approach

#### Factor Approach:

a. Hourly expansion factors, HEF = 
$$\frac{\text{total 24-hr vol.}}{\text{vol. for particular hr.}}$$

These factors are used to expand counts of durations shorter than 24 hr. to 24-hr vol.

b. Daily expansion factors, DEF = 
$$\frac{\text{average total weekly vol.}}{\text{avg. vol. for particular day}}$$

Thses factors are used to determine weekly vol. from counts of 24-hr duration.

c. Monthly expansion factors, MEF = 
$$\frac{\text{AADT}}{\text{ADT for particular month}}$$

These factors are used to determine AADT from the ADT for a given month.

**Table 1 Hourly Expansion Factors for a Rural Primary Road**

Hour	Vol.	HEF	Hour	Vol.	HEF
6:00-7:00 a.m.	294	42.01	6:00-7:00 p.m.	743	16.6
7:00-8:00 a.m.	426	28.99	7:00-8:00 p.m.	706	17.5
8:00-9:00 a.m.	560	22.05	8:00-9:00 p.m.	606	20.4
9:00-10:00 a.m.	657	18.8	9:00-10:00 p.m.	489	25.3
10:00-11:00 a.m.	722	17.11	10:00-11:00 p.m.	396	31.2
11:00-12:00 p.m.	667	18.52	11:00-12:00 a.m.	360	34.3
12:00-1:00 p.m.	660	18.71	12:00-1:00 a.m.	241	51.2
1:00-2:00 p.m.	739	16.71	1:00-2:00 a.m.	150	82.3
2:00-3:00 p.m.	832	14.84	2:00-3:00 a.m.	100	124
3:00-4:00 p.m.	836	14.77	3:00-4:00 a.m.	90	137
4:00-5:00 p.m.	961	12.85	4:00-5:00 a.m.	86	144
5:00-6:00 p.m.	892	13.85	5:00-6:00 a.m.	137	90.2
Total daily volume = 12350					

**Table 2 Daily Expansion Factors for a Rural Primary Road**

Day of Week	Volume	DEF
Sunday	7,895	9.515
Monday	10,714	7.012
Tuesday	9,722	7.727
Wednesday	11,413	6.582
Thursday	10,714	7.012
Friday	13,125	5.724
Saturday	11,539	6.51
Total weekly volume = 75,122		

**Table 3 Monthly Expansion Factors for a Rural Primary Road**

Day of Week	ADT	MEF
January	1350	1.756
February	1200	1.976
March	1450	1.635
April	1600	1.482
May	1700	1.395
June	2500	0.948
July	4100	0.578
August	4550	0.521
September	3750	0.632
October	2500	0.948
November	2000	1.186
December	1750	1.355
Total yearly ADT volume =		28450
AADT =		2371

**Problem:**

A traffic engineer urgently needs to determine AADT on a rural primary road that has the volume distribution characteristics shown in Tables 1, 2 & 3. The engineer collected data shown below on a Tuesday during the month of May. Determine the AADT of the road.

Hour	Volume
7:00-8:00 a.m.	400
8:00-9:00 a.m.	535
9:00-10:00 a.m.	650
10:00-11:00 a.m.	710
11:00-12:00 p.m.	650

**Solution:**

\* Estimate the 24-hr vol. for Tuesday using the factors given in Table 1:

$$\frac{(400 \times 28.99 + 535 \times 22.05 + 650 \times 18.8 + 710 \times 17.11 + 650 \times 18.52)}{5}$$
$$= 11960$$

\* Adjust the 24-hr volume for Tuesday to an average volume for the week using the factors given in Table 2:

$$\text{Total 7-day volume} = 11960 \times 7.727$$
$$\text{Average 24-hr volume} = \frac{11960 \times 7.727}{7} = 13202$$

\* Since the data were collected in May use the factor shown in Table 3 to obtain the AADT:

$$\text{AADT} = 13202 \times 1.395 = 18417$$

## SPEED STUDIES

### Introduction

- It is a basic measure of traffic and roadway performance
- Influence the traveler in selecting routes or transportation modes

### Definition

Speed – The rate of movement of a vehicle, generally expressed in fps, kph or mph.

### Objectives

The main objectives of speed studies are:

- Capacity studies
- Geometric design
- Accident analysis
- Economic studies
- Performance study of a traffic control measures (before & after studies)
- Planning and designing traffic control measures viz:
  - Traffic signal design
  - Designing road signs
  - Designing parking crossings
  - Establishing speed limits
  - Speed zoning
  - Placing speed breaker etc.

### Factors Affecting Speeds

Vehicles speed depend on:

- Roadway geometric, operating and surface conditions
- Amount of side frictions
- Traffic conditions
- Location along the road
- Time of the day
- Weather conditions

### Types of Speeds



- **Time-mean speed** : The speed obtained when the sum of all values is divided by the number of observation. It gives *arithmetic mean* of the spot speeds vehicles passing a point. Useful for traffic regulation purposes.

$$\bar{v}_t = \frac{\sum v_t}{n}$$



where:  $v_t$  = individual speeds  
 $n$  = no. of observation

- **Space-mean speed** : The speed obtained when speeds are averages over space. It gives the *harmonic mean* of the speeds of vehicles passing a point, on a highway, during an interval. Useful for establishing speed-flow relationship.

$$\bar{V}_s = \frac{n}{\sum 1/\bar{v}_t} = \frac{nS}{t}$$

where:  $s$  = space distance  
 $t$  = mean travel time.

### Example

The following travel times were observed for 4 vehicles traversing a 1 mile segment of highway:

Vehicle	Time (min)
1	1.6
2	1.2
3	1.5
4	1.7

Calculate the space and time mean speeds of the vehicles.

$$\begin{aligned}
 \text{Time Mean Speed} &= [(1/1.6)+(1/1.2)+(1/1.5)+(1/1.7)]/4 \\
 &= 0.68 \text{ miles per minute} = 40.8 \text{ mph} \\
 \text{Space Mean Speed} &= 4/(1.6+1.2+1.5+1.7) \\
 &= 0.67 \text{ miles per minute} = 40.0 \text{ mph}
 \end{aligned}$$

### Different Forms of Speed

- Spot speed** : instantaneous speed of a vehicle at a pt.
- Running speed** : average speed while in motion
- Journey speed** : overall speed including stops
- Operating speed** : the highest overall speed
- Free flow speed** : when drivers face no restriction in driving and can maintain their desired speeds.
- Safe speed** : 85<sup>th</sup> percentile speed
- Design speed** : 98<sup>th</sup> percentile speed
- Median speed** : 50<sup>th</sup> percentile speed
- Modal speed** : speed at the highest frequency
- Pace** : is a range of speed; usually taken in 10 mph or 15 kmph increment
- Speed limits** : upper limit at 85<sup>th</sup> percentile speed  
lower limit at 15<sup>th</sup> percentile speed



### Methods of Speed Measurement

**Spot/Time-mean speed** - measured at free flow/unobstructed conditions by using:

- Manual method - measuring travel time over a short distance
- Automatic methods
  - Radar speed meters
  - Pressure contact strip
  - Video camera method
  - Tachometer/graph

**Travel/Space-mean speed** - measured at existing operating condition by using:

- License plate method
- Floating car method - by use of test vehicle
- Elevated observer method

### Presentation of Speed Data

Graphically in the form of

- Histogram & frequency curve
- Cumulate frequency distribution curve
- Statistical distribution

### Problem

Following data was collected while conducting spot speed studies at certain stretch of a road within the urban area. Determine:

- average speed of traffic stream
- modal speed and pace of the traffic stream.
- upper and lower values of speed limits for regulation
- design speed for checking the geometric design

**Solution**

Speed Range (kmph)	No. of vehicle observed (f)	Mid- speed, V (kmph)	% Frequencies	Cumulative % Frequencies
0 - 5	0	2.5	0.00	0.00
5 - 10	5	7.5	0.61	0.61
10 - 15	18	12.5	2.19	2.80
15 - 20	40	17.5	4.87	7.66
20 - 25	110	22.5	13.38	21.05
25 - 30	200	27.5	24.33	45.38
30 - 35	250	32.5	30.41	75.79
35 - 40	120	37.5	14.60	90.39
40 - 45	40	42.5	4.87	95.26
45 - 50	20	47.5	2.43	97.69
50 - 55	11	52.5	1.34	99.03
55 - 60	6	57.5	0.73	99.76
60 - 65	2	62.5	0.24	100.00
65 - 70	0	67.5	0.00	100.00
<b>Total</b>	<b>822</b>			

$$V_{avg} = \frac{\text{Sum}(f \cdot V)}{\text{Sum}(f)}$$

$$= 30.73 \text{ mph}$$

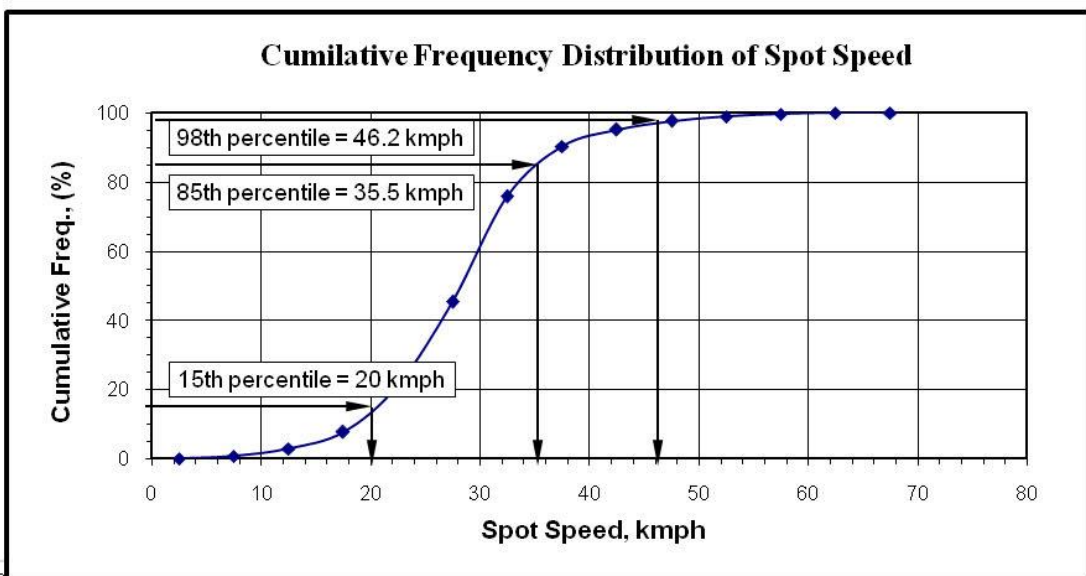
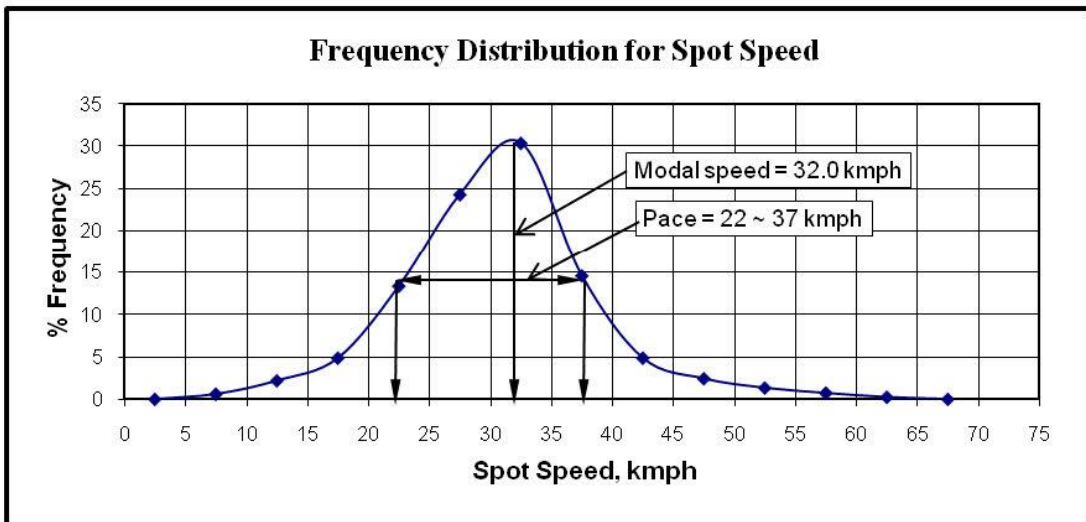

## Comparison of Mean Speeds

Ref. Traffic and Highway Engineering by Grabber, p 97.

- \* Before-after study of spot-speeds is needed to measure the effectiveness of a counter measure. 
- \* This is done by comparing the difference between two sample mean speeds by using statistical Z-test.
- \* Assuming that two sample means are from the same distribution.
- \* In traffic engineering studies, it is usual to perform the test at 95% confidence level.

**Check if**  $Z = |u_1 - u_2|/S_d > Z_{\text{critical}}$

Where;  $S_d = \text{sqrt}[S_1^2/n_1 + s_2^2/n_2]$

$u_1$  = mean speed of before study

$u_2$  = mean speed of after study

$n_1$  = sample size for before study

$n_2$  = sample size for after study

$S_d$  = standard deviation of the difference in means

$S_1$  = standard deviation for before study

$S_2$  = standard deviation for after study

$Z_{\text{critical}}$  = Critical value at a particular confidence level  
= 1.96 at 95% C.L. or 5% LOS

### Problem:

Spot speed data were collected at a section of highway during and utility maintenance work. The speed characteristics are given below. Determine whether there was any significant difference between the average speed at the 95% confidence level.

$$\begin{array}{ll} u_1 = 35.5 \text{ mph} & u_2 = 38.7 \text{ mph} \\ S_1 = 7.5 \text{ mph} & S_2 = 7.4 \text{ mph} \\ n_1 = 250 & n_2 = 280 \end{array}$$

### Solution:

$$\begin{aligned} S_d &= \sqrt{S_1^2/n_1 + S_2^2/n_2} \\ &= \sqrt{7.5^2/250 + 7.4^2/280} \\ &= 0.65 \text{ mph} \end{aligned}$$

$$Z_{\text{critical}} = 1.96 \text{ at } 95\% \text{ confidence level}$$

$$\begin{aligned} \text{Now, } Z &= |u_1 - u_2|/S_d \\ &= |35.5 - 38.7|/0.65 \\ &= 4.92 \end{aligned}$$

As  $Z > Z_{\text{critical}}$ , it can be concluded that the difference in mean speeds is significant at 95% confidence level.



## DELAY STUDIES

### Introduction

- It is a modified form of the speed study
- It measures the average journey time

### Objectives

- To find out the locations, causes and duration of the delay/congestion
- To prescribe the remedied measures of congestion
- To assess the quality/efficiency of road network
- For economic evaluation of improvement measures
- To evaluate the performance of particular measure
- For travel demand management/route guidance

### Causes of Delay

- Fixed/Geometric delay** — Delay incurred due to roadway geometry. It occurs mainly due to road intersections/signals, narrow road/bridges, sharp horizontal and vertical curves etc. It is unavoidable and almost same for all vehicles.
- Operational Delay**  — It is mainly caused by road-side and inter-vehicular frictions such as:
  - road side parking
  - road side non-motor activities
  - road side pedestrians movements and random crossings
  - bus stoppage near intersections
  - high traffic volume and lack of roadway capacity
  - merging, turning, lane changing/overtaking or weaving maneuvers etc.

Traffic engineers are interested about the operational delay which is fluctuating in nature and controllable.

### Delay/Congestion

Indicates the situation when extra time is needed to travel through a roadway facility.

### Types of Delay/Congestion

- Non-recurrent Delay**: which is unpredictable in nature and occurs due to the following random events:
  - flow break down at peak periods (make shock wave - which quickly amplify and propagate to down stream)
  - accidents 
  - special events (sports, national events etc.)
  - signal malfunction etc.
- Recurrent Delay**: which occurs periodically at particular locations and particular time of a day.
  - daily morning/evening peak periods congestion due to rush commuter movements
  - congestion other than the peak periods on all purposes roads due to increased flow level

### Data Collection Methods

- Manual**
  - Floating car method
  - Random car selection method
- Auto data acquisition techniques**
  - based on road occupancy rate - presence inductive loop detectors
  - based on vehicles speeds - radar devices (ultra sound/ infrared beams)
  - based on travel time - between
    - two consecutive CCTVs with machine vision license plate reader (LPR) system
    - two gantries with microwave transmitters and in-vehicle electronic card/tag system
  - based on in-vehicle tachometer and GPS antenna

### Presentation of results

Speed and delay data may be presented in tabular or graphical form to show speeds and speed variation profiles along the route being studied together with the locations, causes and duration of delays.



## ORIGIN AND DESTINATION (O-D) SURVEYS

### Introduction

- ❑ Traffic volume counts give the amount of traffic passing at specified locations on the road but they do not indicate where traffic desires to travel i.e. its origin and its destination.
- ❑ An origin and destination survey is designed to obtain such information about the movements of vehicles and passengers within an area.

### Objectives

- ❑ To know the terminal points of a trips, direction of travel, selection of routes and trip lengths
- ❑ For transportation planning, design and operation of road-network and terminals (particularly the location, design and programming new or improving highways, by-pass, terminals, regulations etc.).
- ❑ For planning and designing public transport and parking facilities etc.
- ❑ For economic evaluation of alternative plans.

### Common Method of Collecting O-D Data

- ❑ **Matching license/registration plate numbers** - at the points of entry and exit of a cordon area; plate nos. can be recorded manually or using video camera.
- ❑ **Post card survey** - Cards are handed to drivers as they pass the station. Stations can be located where the vehicles have to proceed slowly (usually at junctions/bridge entrances etc.)
  - ❑ Cards should have prepaid postage and be self-addressed
  - ❑ The number of question is limited to five or six
  - ❑ Wording of questions should be very simple
  - ❑ Different colors may be used to distinguish between census stations
  - ❑ Advance publicity is essential to ensure public co-operations
- ❑ **Road side interview** - Drivers are stopped with the help of police and questioned about their
  - ❑ Origin , destination & trip length and purpose
  - ❑ Route choice to reach destination
  - ❑ Location of stops & purposes
- ❑ **Tag-or sticker method** - Pre-coded tags are placed on vehicles as they enter into the study area and removed as they leave the area. The time, station and direction of travel are recorded on the tags.
- ❑ **Telephone interview** - need advance publicity
- ❑ **Home interview** - It is very expensive and usually conducted when, besides O-D data, comprehensive information is required for planning & designing new transport strategies.

### Presentation of results

The results are usually expressed in the form of desire-line-graphs - which represent trip nos. between zone of origin to destination. The greater the band thickness the greater being the number of trips. The desire lines density easily reflects the necessity of new links, diversions, by-passes, regulations etc.

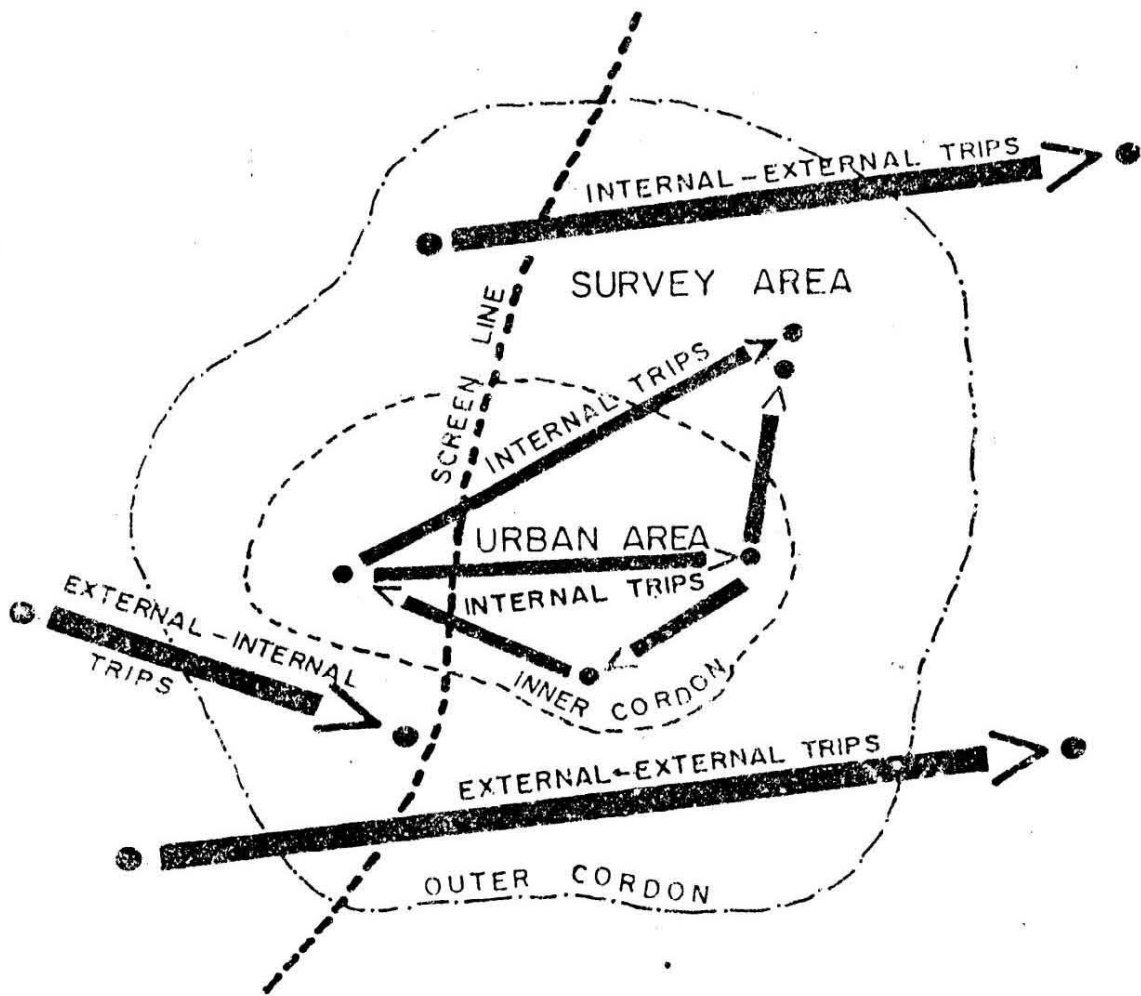

\* Fig. 3 DIAGRAMMATIC REPRESENTATION OF BASIC MOVEMENT

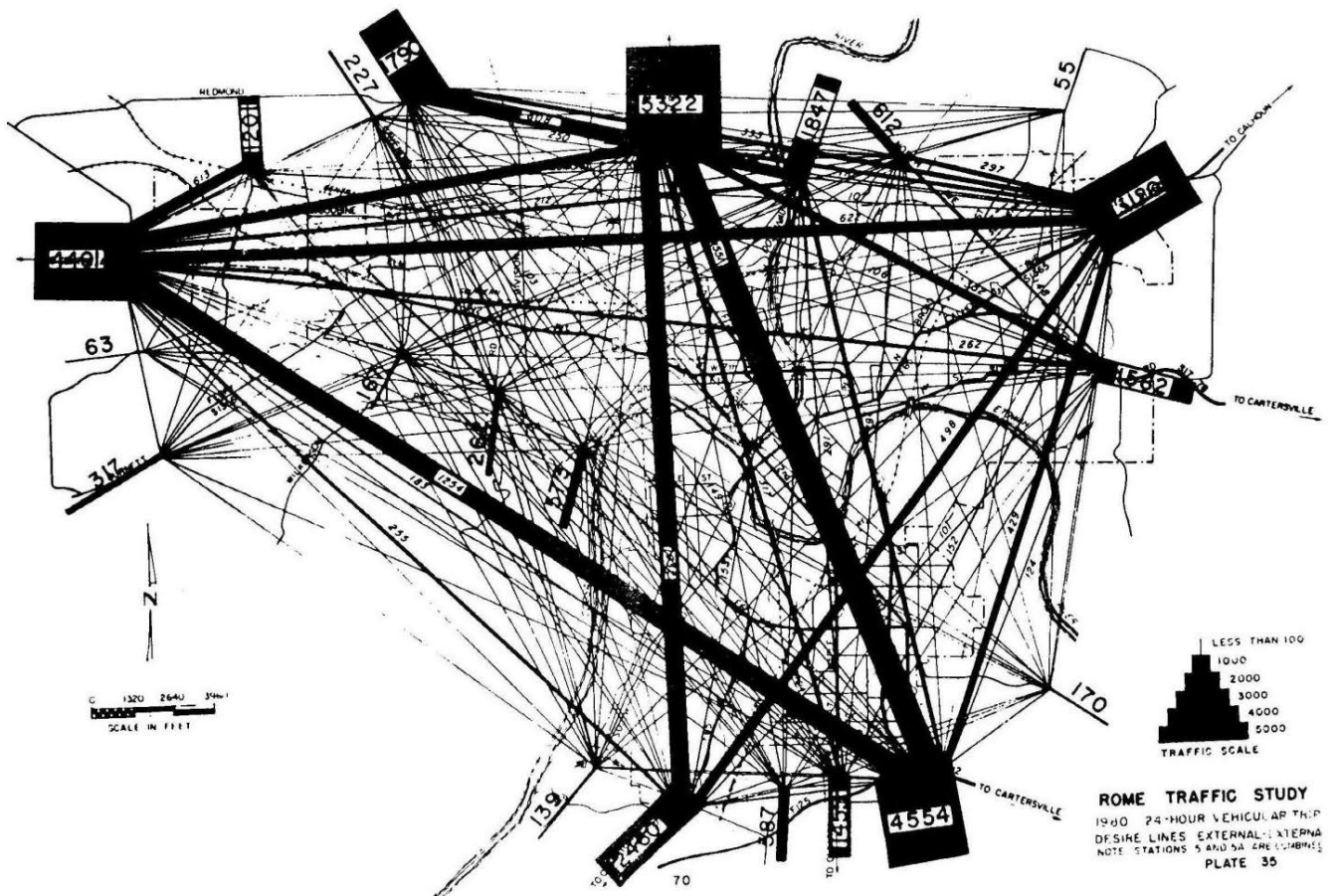
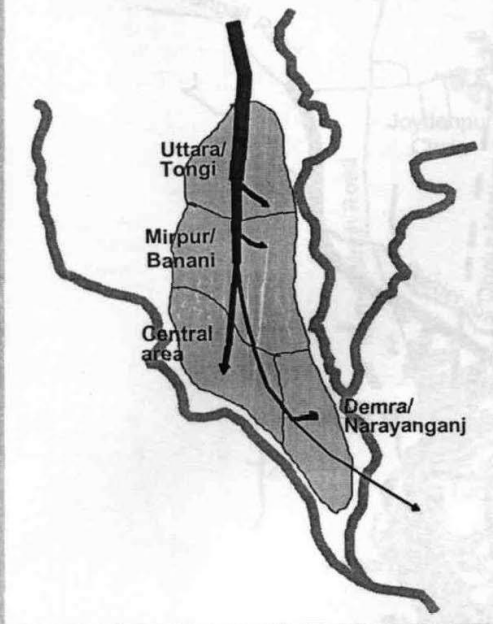

FIGURE 3-6 A desire line map. (Courtesy Georgia Department of Transportation.)

# Dhaka Eastern Bypass Study

From Mymensingh Road



From Chittagong Road

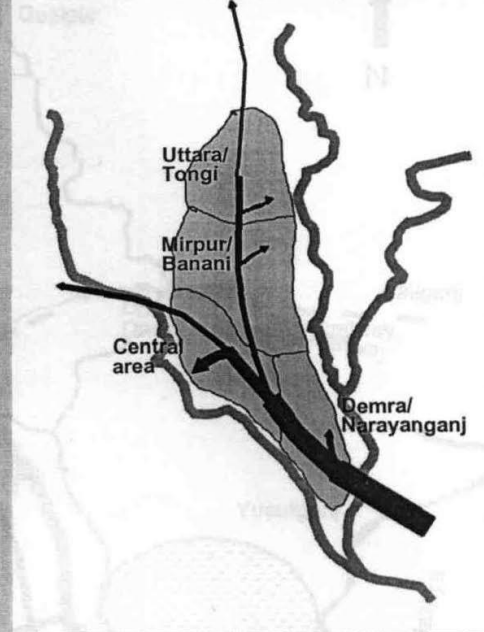

From Aricha Road

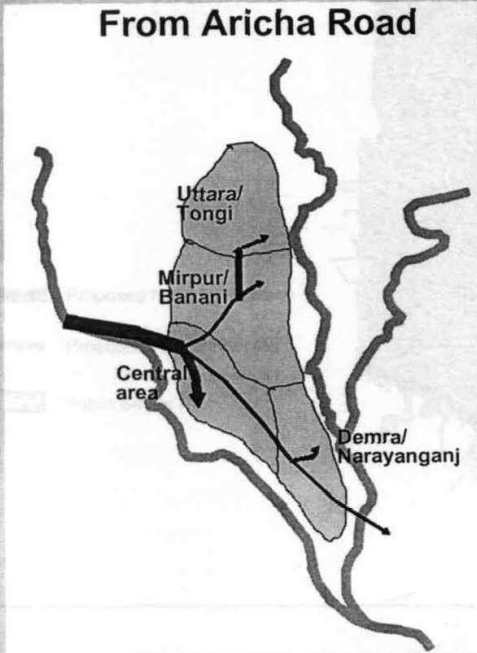

From Mawa Road

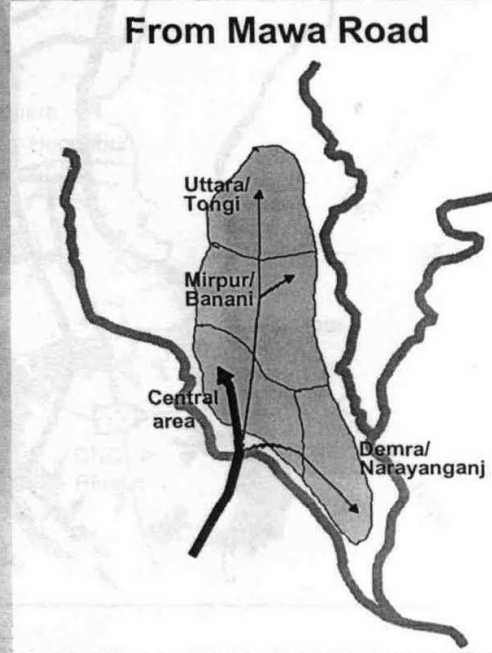

Dhaka Eastern Bypass Study  
Destination Patterns Within Dhaka  
Trucks

Halcrow Fox

Fig. No. 2.3

## PARKING STUDIES

### Introduction

- Parking studies mainly for car
- Usually conducted for urban areas with high demand for parking
- Parking is essential for business & commercial activities
- It should be an integral part of roadway system and provision of off-street parking spaces should be considered at the urban planning stage
- It is roughly estimated that out of 8,760 hours in a year, the car runs on an average for only 400 hours (4.5%), leaving 8,360 hours when it is parked.
- Parking control has potential to improve roadway capacity and safety

### Problems Associated with Uncontrolled On-street Parking

- Reduce roadway capacity (as it reduces effective width of road and parking/unparking maneuver interrupts free flow of vehicles) and consequently
  - causes congestion
  - causes serious economic losses to the community (due to increase of journey time, delay, vehicle operating cost, pollution etc.)
- Encourage road side non-motor activities (increase side frictions)
- Unmarked/uncontrolled parking leads less efficient use of road side spaces
- Loss of revenue
- Makes roadway operation unsafe and haphazard
  - in general on-street parking maneuver contribute to about 10% vehicular accidents (due to reversing from angle park) and 8-10% of pedestrian fatalities
  - common causes of parking related accidents
    - searching parking space and stopping suddenly
    - moving out from stopped position and merging with main stream traffic
    - due to reversing from parallel park (hitting children at the rear end)
    - careless opening of the doors of parked vehicles
    - pedestrian crossings near the parked vehicles, etc. (obstruct sight distance)

### Objectives of Parking Studies

- To obtain information regarding supply and demand of parking spaces
- To develop systematic on-street parking facilities/ regulations (i.e. road side management)
- To improve existing on-street facilities (i.e. updating parking regulations/time limits, fees etc.)
- To develop new off-street parking facilities (i.e. fixing type, size, location, regulation etc. of parking facilities)

### Parking Studies Include

- Supply Surveys** - To know parking supply/space available in the area under consideration by conducting:
  - Space inventories* – listing all the existing parking facilities and open spaces available for adopting as parking places as well as listing areas where parking should be prohibited (viz. Bus stops, clear-ways, driveways/entrances, safety zones etc.).
- Demand Surveys** -To know parking demand including even who are searching for spaces by conducting:
  - Field observation* – recording location, type of vehicle, number of parking vehicles, duration of parking etc.
  - Interview* – questionnaire survey.

For proper implementation of a parking scheme, besides parking supply and demand, information regarding roadway capacity and flow fluctuations in both directions of road is to be known.

### Parking should be prohibited at

- Intersections
- Narrow Streets
- Driveways
- Pedestrian crossing
- Curvature and grade conditions
- Road bridges & tunnel
- Heavy pedestrian concentrations areas
- Priority locations - bus stops, fire hydrants etc.

### Types of Parking Facilities

- ❑ **On-street/curb parking**
  - ❑ vehicles parked along the curb
  - ❑ usually for short stay
  - ❑ very convenient for the people (less walking)
  - ❑ preferably parallel method of parking
  - ❑ may be of charged or free
- ❑ **Off-street parking**
  - ❑ when parking places are provided away from the road curb
  - ❑ usually for long stay
  - ❑ requires walking of quite a large distance to reach the destination
  - ❑ preferably angle parking with common isle
  - ❑ types
    - ❑ back street (specially where there is no or minimum through traffic movements)
    - ❑ surface car parks/parking lots
    - ❑ multi-storied car parks
      - ❑ self parking system – using ramps
      - ❑ auto parking system – using elevators
    - ❑ basement car parks – usually for private uses

### Common Methods of Parking

- ❑ **Parallel parking**
  - ❑ Total space required for parking and unparking maneuvers is least
  - ❑ Parked vehicle takes least roadway width but consumes maximum curb length
  - ❑ Maneuver is very difficult, as for proper parking and unparking some forward and backward movements are essential (especially high skill is necessary to park between two vehicles)
  - ❑ Relatively parking maneuver takes more time than unparking maneuver
  - ❑ Near-side door opening and get down from car using off-side is unsafe and need extra care
  - ❑ It is usually recommended for road with narrow width or with high volume of through traffic
- ❑ **Angle parking**
  - ❑ Total space required for parking and unparking maneuvers increases with increase in angle of parking
  - ❑ Parked vehicle takes more roadway width but consumes less curb length and it decrease as the angle of parking increases
  - ❑ Maneuver is more convenient/easier than parallel parking
  - ❑ Relatively parking maneuver takes less time than unparking maneuver and as such parking maneuver causes less interference to through traffic than the parallel parking. Whereas, unparking maneuver is not easily executed because most of the reversing, car has to project into the traffic lane to get an unobstructed view – this produces more interruption to through traffic and causes hazardous situation.
  - ❑ It is usually recommended for off street parking and on exceptionally wider road or road with low volume of through traffic.

### Design Parking Vehicle

- ❑ It is determined based on the dimension of 85<sup>th</sup> percentile of cars being used in the study area. For bay design there is a needed to add allowances for door openings and for isle design space required for parking and unparking maneuvers is to be considered. Suggested bay sizes for curbside parking (AUSTRALIA):

Angle of Parking Degree	Bay Width(m)	Bay Length(m)
0(parallel)	2.3	6.7
30	2.6	4.7
45	2.6	5.3
60	2.6	5.5
90	2.6	5.9

### For systematic development of parking facilities there is a need to

- ❑ identify areas suitable for on-street parking and mark them properly
- ❑ impose restriction on parking at unauthorized places
- ❑ improve walking facilities
- ❑ introduce parking charge and time limit
- ❑ know demand elasticity
- ❑ develop off-street parking

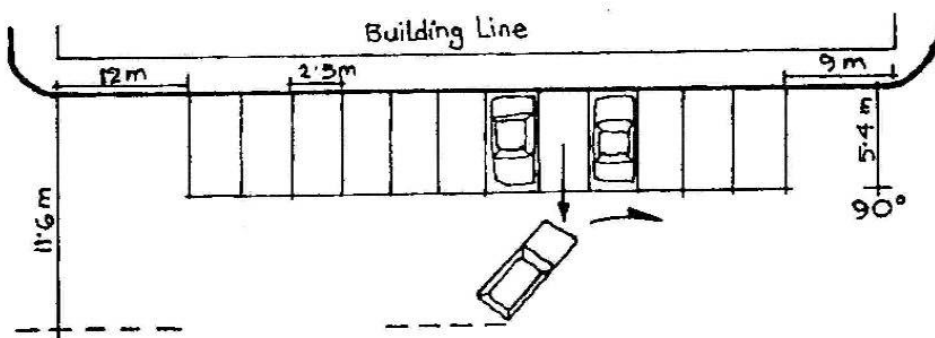
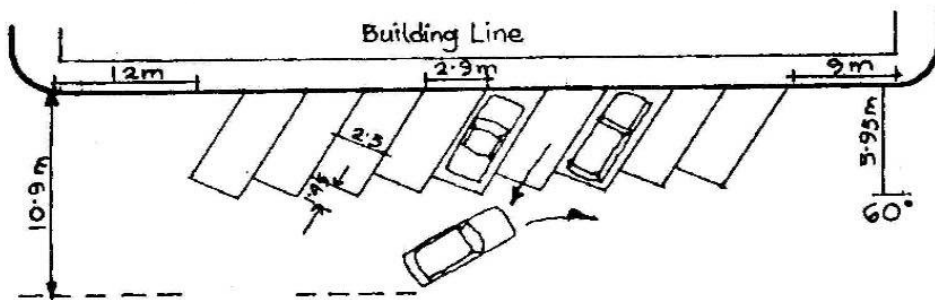
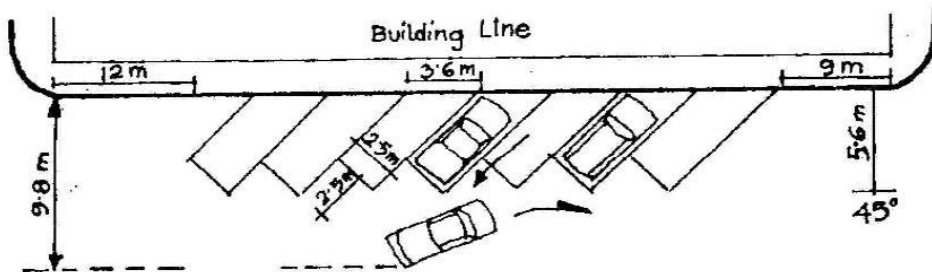
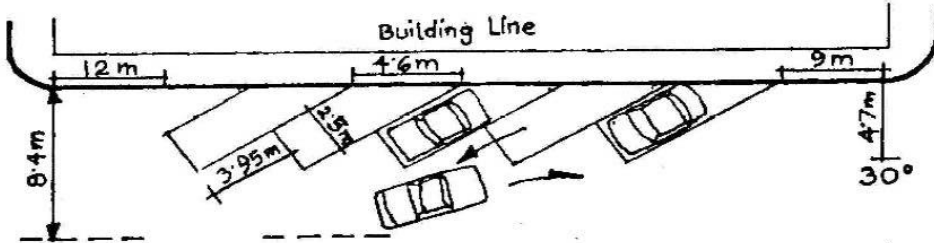
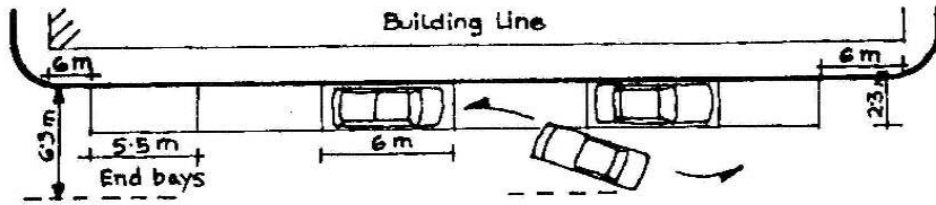

## Different Types of Parking Arrangements





**Multi-storied off street parkings**

## TRAFFIC CONTROL DEVICES

### Introduction

Traffic control devices include all

- signs
- markings
- signals

### Objectives

- to regulate
- to warn
- to guide traffic movements and thereby
- to ensure safe and smooth flow of traffic movements

### General requirements

Traffic control devices sh



- fulfill a need** – must be reasonable and appropriate for the traffic requirements at the locations used
- command attention & respect of drivers and pedestrians** – must not be used where it is not warranted; otherwise it will invite drivers to disregard and to have less respect for traffic control devices in general
- convey a clear, simple meaning** - legible at long range and understandable at a glance
- be place so as to give users time for proper response**
- be uniform in design and application** – the size, shape, color of the device/letter/symbol, mounting height, siting and lighting should be uniform and consistent
- be visible both at day & night**
- be maintained at high standard** - to ensure legibility and visibility
- generally as some control devices impose restriction on vehicle movements – it is recommended that
  - these should **be use conservatively** to avoided disrespect by the drivers – if used in excess, tend to lose their effectiveness.
  - moreover, these should **not be used alone**, where enforcement is required to compel drivers to obey them.

### How these requirements are met?

- design
- placement
- uniformity
- operation
- maintenance

## TRAFFIC SIGNS

### Introduction

Traffic signs are mainly used to

- inform drivers about regulations
- adjust their lane position, speed
- guide them to reach their points of interest



### Classification

Functional classes of traffic signs are:

- Mandatory Signs** (shall follow)
    - inform users of traffic laws or regulations
    - the violation of these signs is a legal offence
  -   these are usually circular in shape with red border, white background
  - Examples
    - Regulatory
      - slow/slop
      - keep right
      - restriction on speed, size, weight
      - one way traffic etc.
    - Prohibitory
      - no right/left/U turn
      - no entry for vehicle types
      - no overtaking
      - no horn
      - no waiting/parking etc.
    - Special mandatory signs for priority typed intersections
      - STOP
        - used when vision is obstructed
        - USA/UK practice – octagonal, red background, white border
      - YIELD/GIVE WAY
        - used when vision is not obstructed and stop is needed only when necessary
        - USA/UK practice – triangular pointing down ward
- Warning or Cautionary Signs** (should follow)
  - These are known as safety signs
  - Not always an offense if not complied with
  - Usually equilateral triangle or diamond in shape
  - These signs convey message to warn about potentially hazardous conditions ahead and where some caution/attention is required for examples:
    - side road
    - junctions
    - level crossing
    - zigzag/slippery road
    - sharp bend
    - road hump
    - narrow bridge
    - school, hospital, cinema hall etc.
- Informatory or Guide Signs** (may follow)
  - These signs show the direction of important places of interests and are used to guide road users along route to make the travel convenient, safe and comfortable
  - Used at a location where the motorist would be in doubt
  - Informatory signs do not lose their effectiveness by over-use and as such it is desirable to use them as frequent as is necessary
  - Usually rectangular in shape
  - Examples
    - route direction
    - points of interests
    - mile stone/distance

### Placement of Signs

- should be located on the left side of the road
- for roads in open/rural area – not be more than 2m from the near side of the carriageway
- for roads in built up area – not more than 0.5m
- for multilane highways, overhead sign is necessary

### Height of Signs

Post height is measured from the pavement surface

- open area – 1.5m
- built-up area – 2.1m

### Size of Lettering

Should be such that they can be easily read when vehicles are moving

- USA practice – size is related to type of highway
- UK practice – based on empirical formula

### New Trend



- increasing use of icons, logos and symbols instead of using letters and words
- increasing use of Variable Message Signs (VMS)

#### VMS:

Conventional signs are very rigid in the sense that they carry fixed and limited information for all road-traffic environments. Whereas, VMS display-panels are used to display real time traffic information. Capable of displaying graphics and/or alphanumeric messages. They are more responsive to the field conditions. Need electricity and data communication facilities.

Display Types	LCD, bulb/amp matrix, LED pixels, flip
Latest VMS	wireless, with solar panels and radio control

### Bangladesh

- absence of complete "Highway Manual"
- faulty designs (inconsistent size, color, wording, incorrect height, placement etc.)
- absence of required signs at potentially hazardous locations
- misuse of signs,
- obstructed signs
- poor maintenance
- existence of misleading signs
- lack of supplementary markings
- presence of a large number of illiterate road users
- eventually all these above factors contributed to lost the respect & effectiveness of traffic signs as controlling device and in consequence, with time a tendency has developed among the road users to ignore the signs
- as power failure is very common, use of retro-reflective signs/markings would be most appropriate even within the city areas

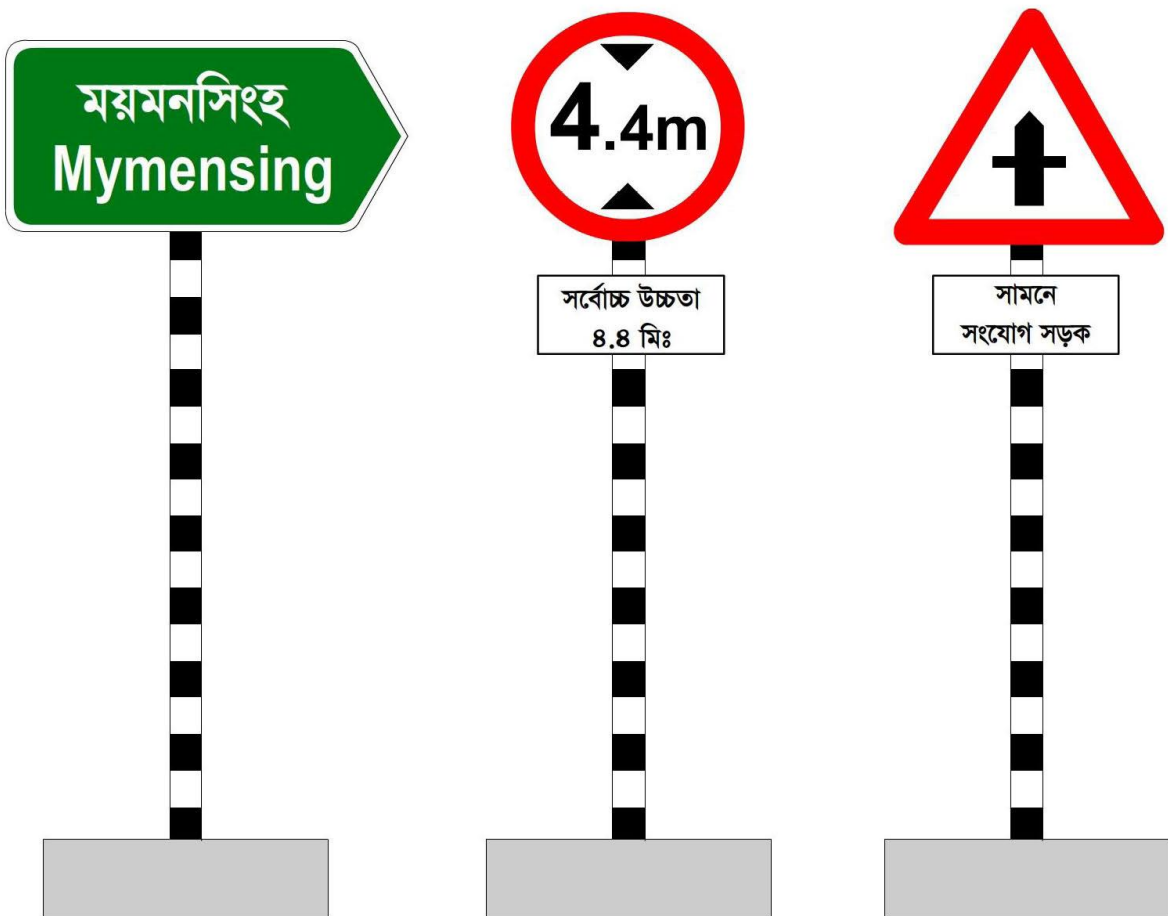
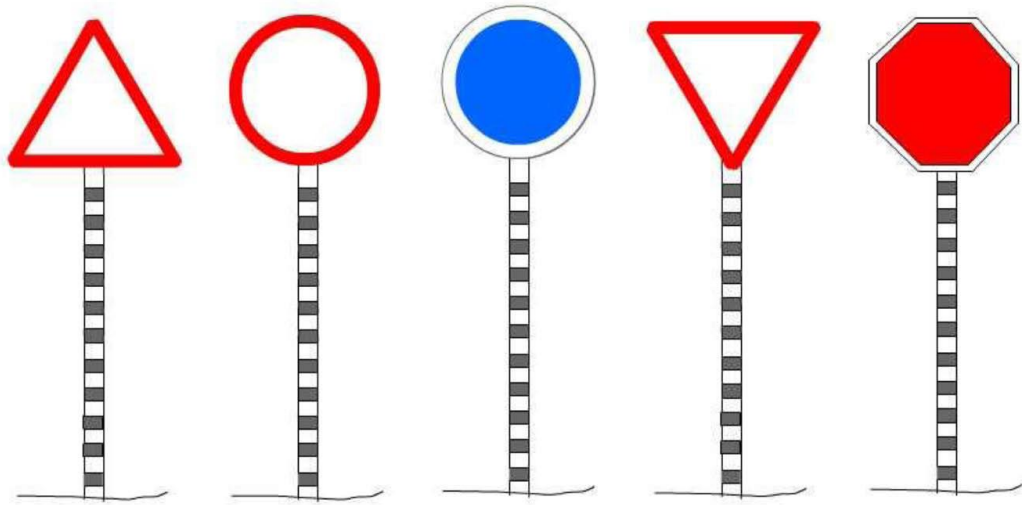



সামনে স্কুল  
SCHOOL



সামনে  
ডানে বাঁক



সামনে  
দুর্বল সেতু

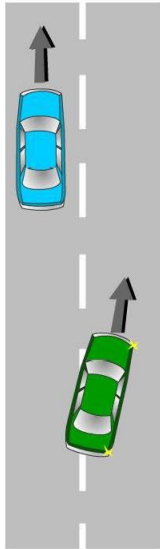
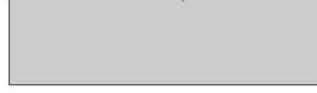
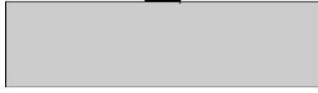

রাস্তার মাঝ বরাবর ভাঙ্গা  
লাইন থাকায়- আশে পাশের  
গাড়ির অবস্থান অনুকূলে থাকলে  
উভয় দিক থেকেই ওভারটেক  
করা যাবে।

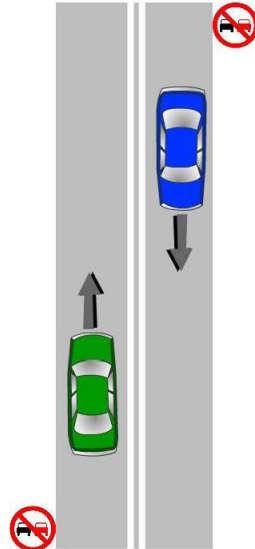

মাঝ বরাবর দ্বৈত অখণ্ড লাইন  
থাকাতে - কোন দিক থেকেই  
ওভারটেক করা যাবে না।  
এটা ট্রাফিক আইল্যান্ড বুঝায়।

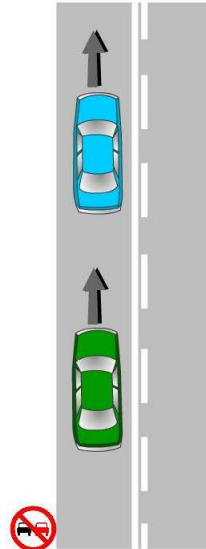

গাড়ি চলাচলের যে দিকে ভাঙ্গা  
লাইন আছে শুধু সেই দিকের  
গাড়ি ওভারটেক করতে পারবে  
বিধায় এখানে সবুজ রং এর  
গাড়িটি ওভারটেক করতে পারবে না।

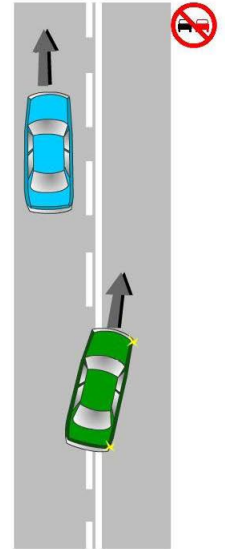

এখানে সবুজ রং এর গাড়িটি  
ওভারটেক করতে পারবে কিন্তু  
বিপরীত দিক থেকে আগত কোন  
গাড়ি ওভারটেক করতে পারবে না।

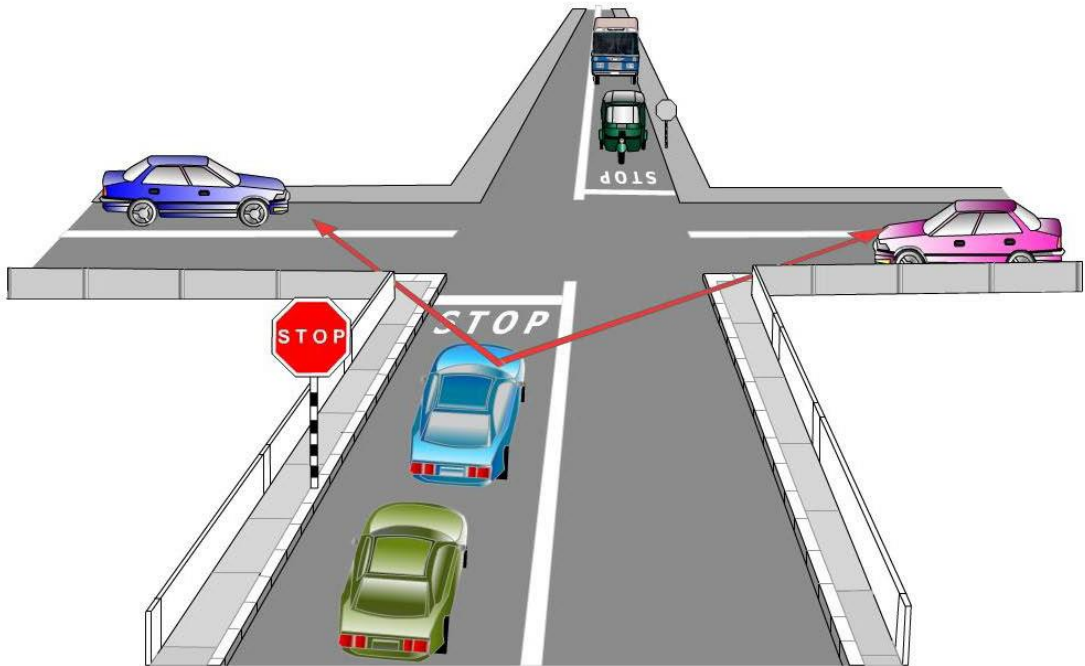
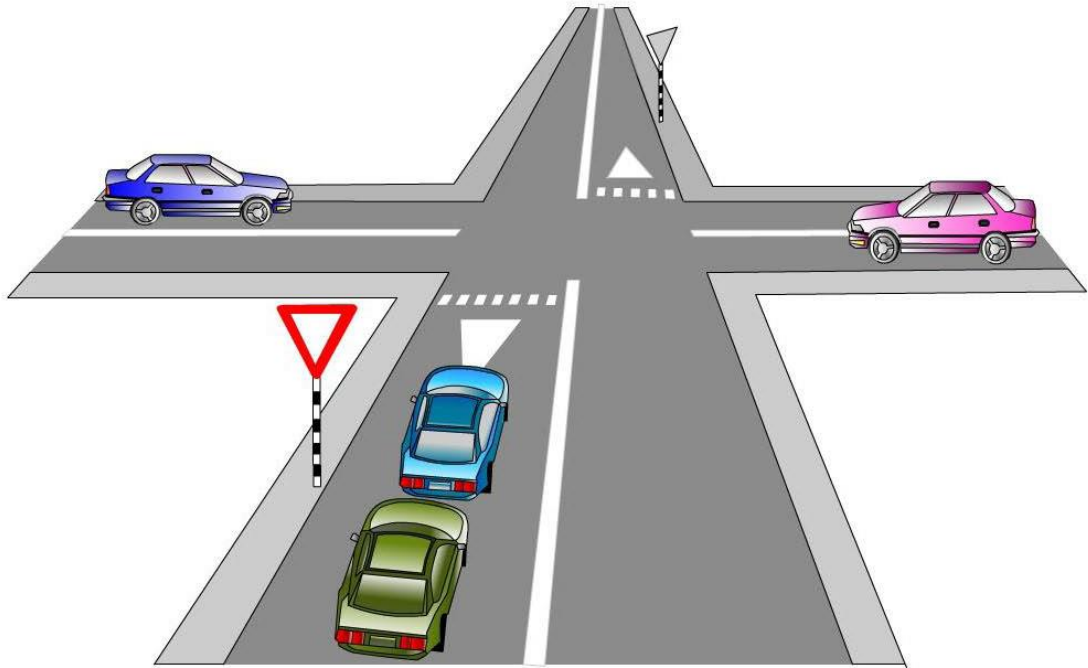

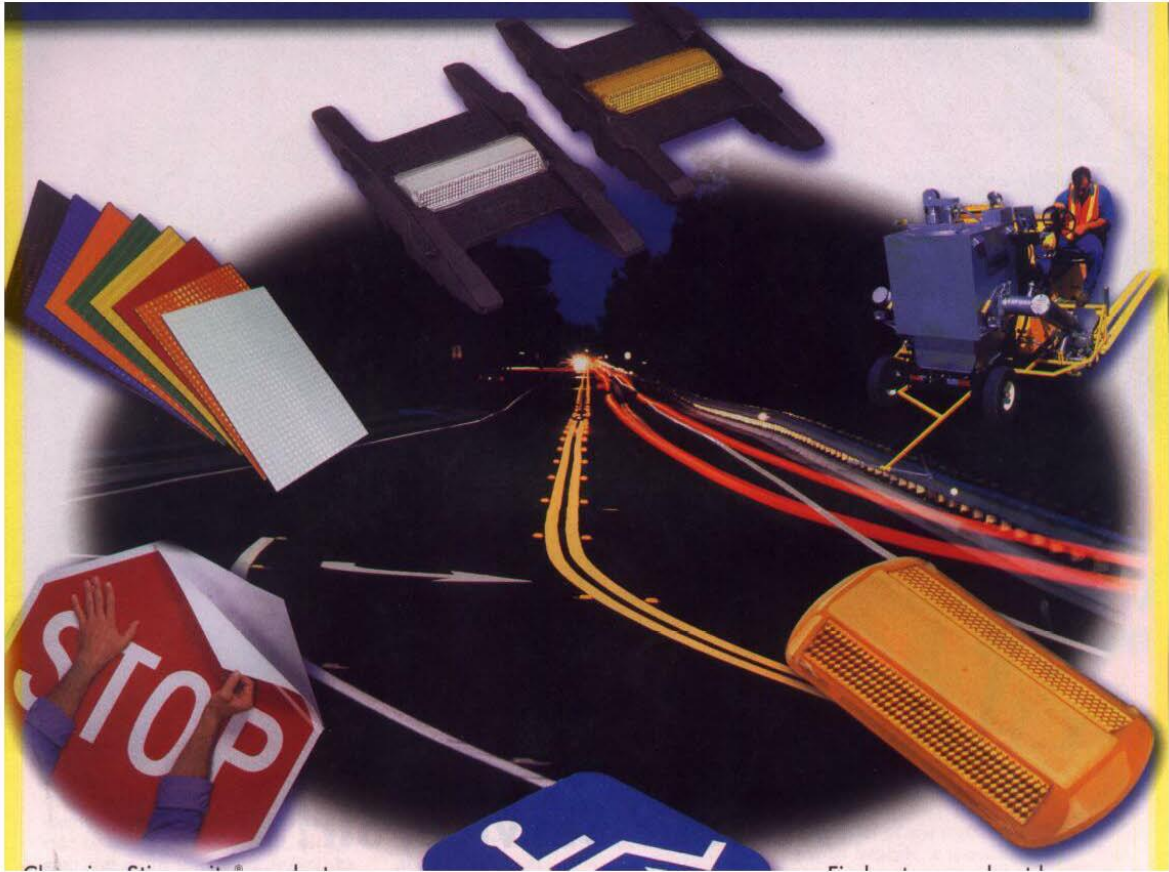

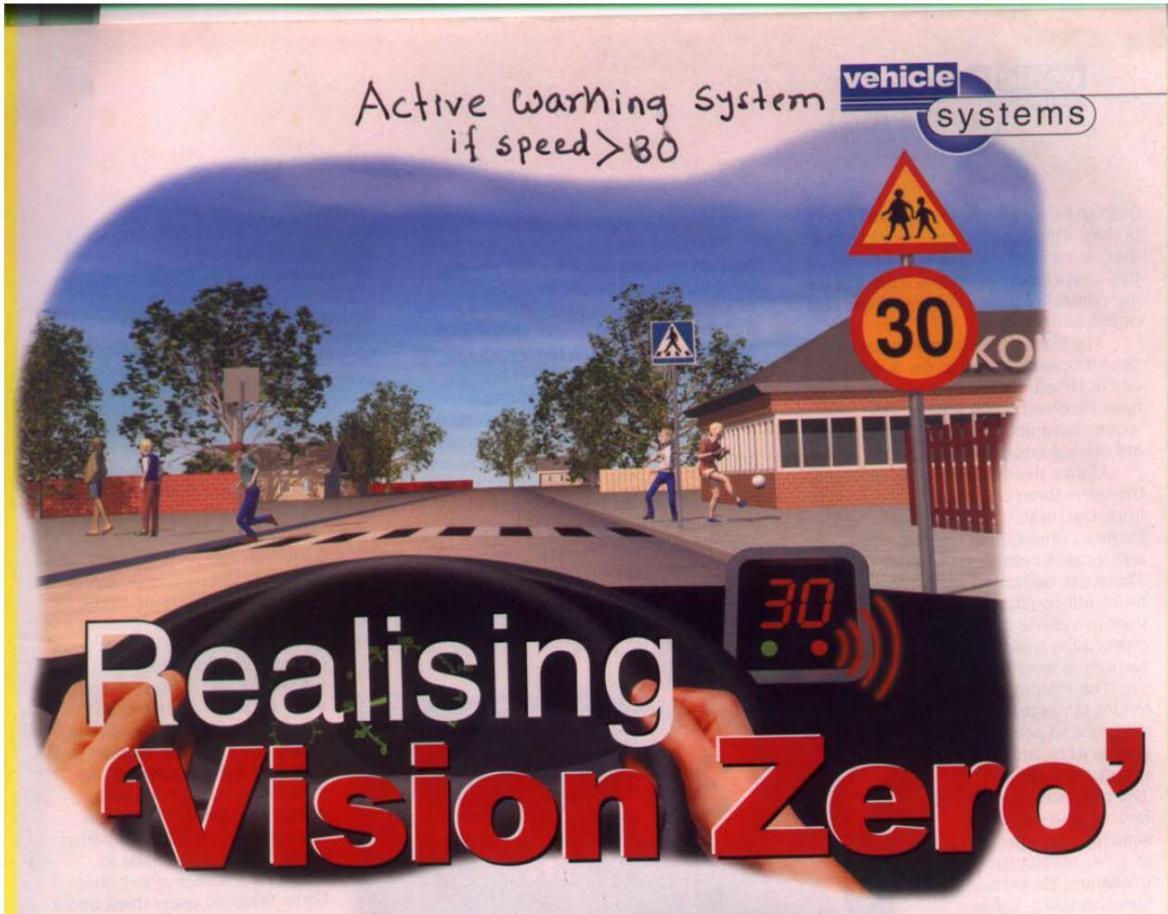

## ROAD MARKINGS

### Introduction

- Road markings are used as a means of controlling and guiding traffic
- They promote road safety and bring about smooth flow of traffic
- Markings consist of paint on the pavement and curb to convey traffic regulations and warnings to drivers
- Markings may be used alone or in combination with traffic signs or signals

### Compared to traffic signs, road markings:

- provides a continuous message to the driver
- convey message to the driver without distracting his attention from the carriageway
- reduces environmental impact (signs can be ugly)
- very expensive
- weather susceptible - ineffective in heavy rain or snow
- less durable - continually wearing away
- less effective at congested traffic condition

### Types of Road Markings

Road marking can be classified as:

- Pavement markings
- Object/curb markings

### Used in the forms of

- Lines
- Stripes
- Words
- Symbols
- Raised Markers

### Markings Materials

- Paint - thermoplastic cement paint (non-reflective/reflective)
- Self-adhesive plastic/aluminum sheet
- Studs (raised marking)
- Glass beads are used to produce retro-reflective/cats-eyes effects of the markings - to aid night driving especially in rural open areas.

### Color Convention (UK)

- White for normal carriageway markings
- Yellow for restrictive markings viz. waiting/parking restrictions, keep clear markings at bus stop, box junction, near school etc.
- Back & white for pedestrian crossings

### Pattern Convention (UK)

- Broken lines are permissive in character
- Solid lines are restrictive in character
- Double lines indicated maximum restrictions

### New Trend

Conventional road markings are effective only at dry weather not during rainy condition as rain water cover the markings and hinder reflection. New type of highly durable plastic retro-reflective material is being used in 4mm thick layer to give lane markings which is visible even during wet (usually 2mm rain water film) condition - it is less expensive than that of cats-eye stud type markings.

### Bangladesh

- use of normal domestic paints for pavement markings
- no uniformity/consistency of road markings
- absence of required markings at potentially hazardous locations
- most of the road users are not aware of the meaning of road markings

## লেকচার-৭,৮: যানবাহন নিয়ন্ত্রণের কৌশলসমূহ

### সড়কপথের আড়াআড়ি গুরুত্বপূর্ণ কিছু রোড মার্কিং

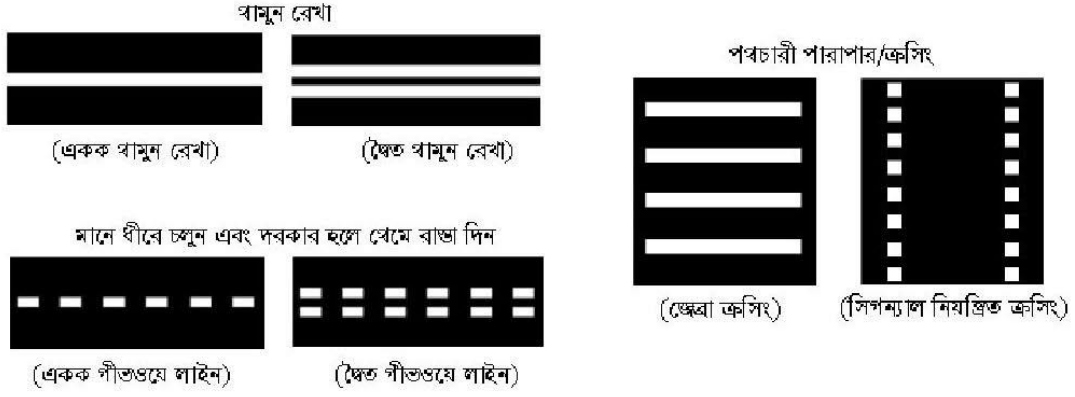

ড্রাইভার ইন্ট্রাকটর প্রশিক্ষন কোর্স

## লেকচার-৭,৮: যানবাহন নিয়ন্ত্রণের কৌশলসমূহ

### সড়কপথ বরাবর গুরুত্বপূর্ণ কিছু রোড মার্কিং



ড্রাইভার ইন্ট্রাকটর প্রশিক্ষন কোর্স

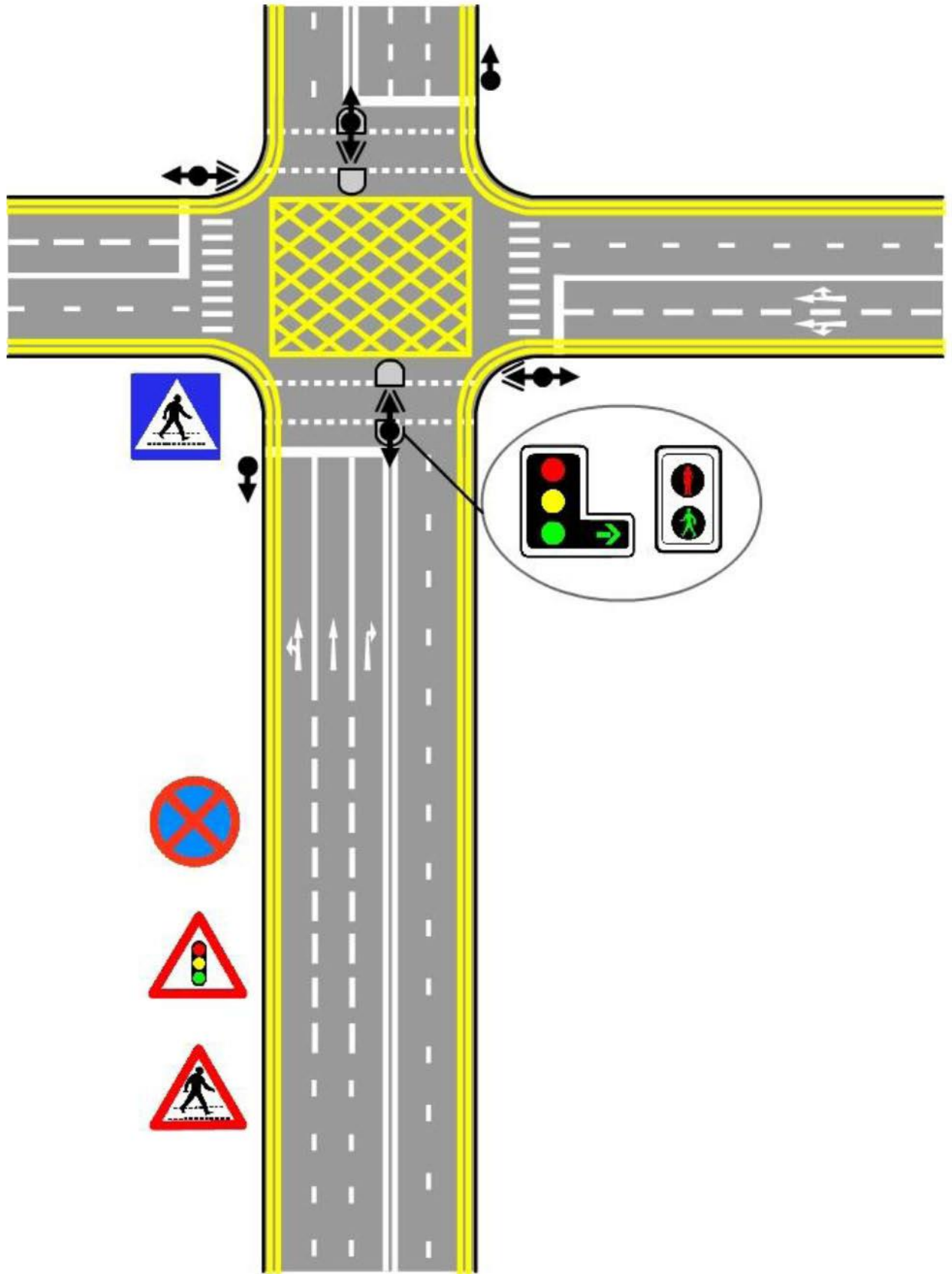

**DIFFERENT ROAD SIGNS AND MARKINGS**

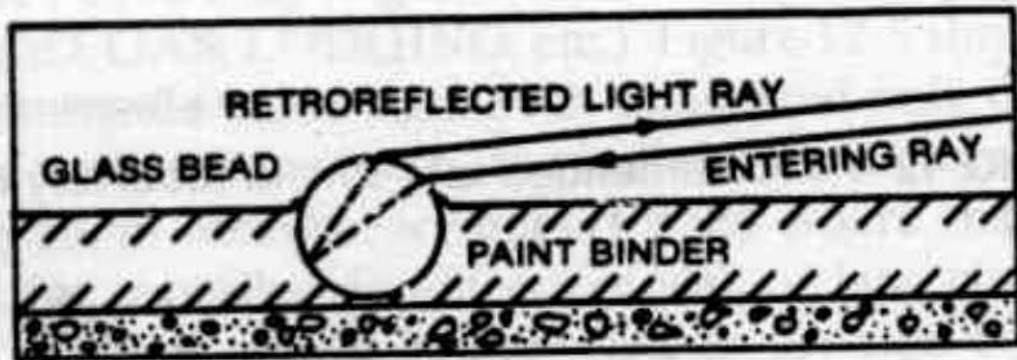
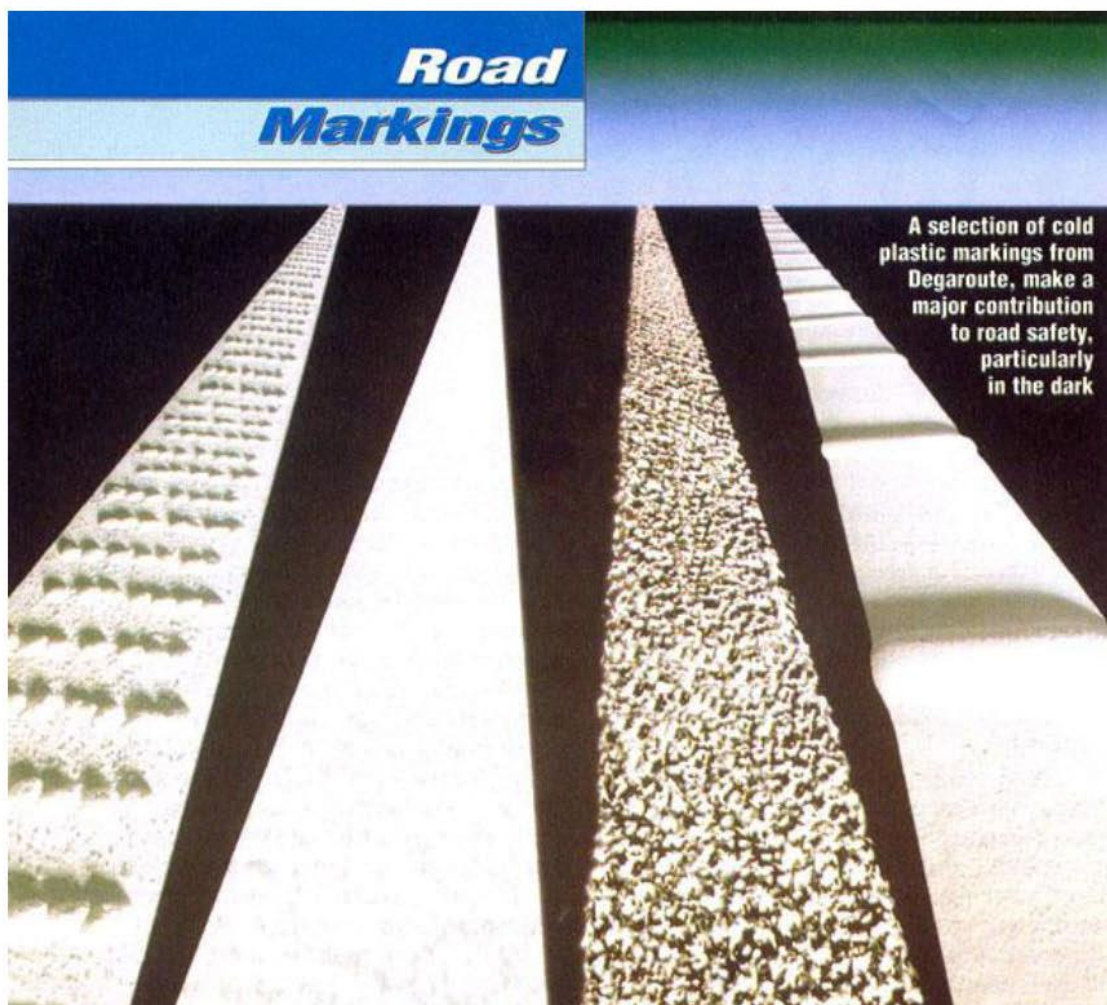

FIGURE 12-6 Glass-bead retroreflection. (Courtesy Federal Highway Administration.)



**TACTILE MARKINGS**

## TRAFFIC SIGNAL

### Introduction

- ❑ it is a physical device which is used to control traffic movement at the junction
- ❑ it replaces the priority regulation of junction operation
- ❑ it assigns the right-of-way by splitting green time to the various traffic movements

### Warrants

- ❑ when traffic flow at uncontrolled/priority-controlled junction becomes high and thereby increases:
  - ❑ traffic conflicts and overall delay;
  - ❑ accidents probability;
- ❑ when manual operation of junction with the help of traffic police becomes very difficult and expensive

### Advantages

- ❑ provide for orderly movement of traffic
- ❑ increase traffic handling capacity of the intersection
- ❑ reduce the frequency of certain types of accidents especially right angle and pedestrian
- ❑ provide for nearly continuous movement of traffic at desired speed along a given route by co-ordination

### Disadvantages

- ❑ at off-peak periods signal controllers with fixed time & plan cause unnecessary delay and increase drivers irritation - in consequence promote disrespect of the signal indication
- ❑ increase in certain types of accidents (especially rear-end collisions- at dilemma zones)

### Signal Installation Considerations

- ❑ Signal should only be used where they are warranted and where they will be respected - traffic signal that cannot be enforced and is routinely disobeyed will weaken the overall level of respect for traffic signals
- ❑ Traffic signals should be kept functioning with quick repair times so that drivers continue to rely on traffic signals.

### Type of Signal Controller

- ❑ **Fixed-time Controllers** (off-line system)
  - ❑ With fixed-time signals the green periods, and hence the cycle times, are predetermined and of fixed duration.
  - ❑ The controllers are simple and relatively cheaper but they are necessarily inflexible and require careful setting.
  - ❑ The controllers can accommodate more than one signal plan to make it more demand responsive.
  - ❑ Can be used as:
    - ❑ *Isolated control system* - for a single intersection
    - ❑ *Linked/coordinated control system* - for closely spaced junctions in a corridor
      - ❑ *Simultaneous* - All the signals along the controlled section display the same aspect of signal to the same traffic stream at the same time. This type of system encourages speeding as some drivers try to pass as many intersections as possible before the signals change.
      - ❑ *Progressive* - The cycle time for each intersection in the system is common but the green periods are staggered in relation to each other according to the distance between intersections and the desired road speed. This system is suitable for streets where distances between intersections are almost equal.
- ❑ **Vehicle-actuated Demand Responsive Controllers** (Online/ real time system)
  - ❑ With this the green times are related to the traffic demands and provision is there to omit a particular phase if there is no traffic.
  - ❑ Need to install detectors on all approaches
  - ❑ Delay is minimized globally
  - ❑ Used as isolated and as well as coordinated system

- **Modern Computer based area coordinated controllers**
  - **Area Traffic Control (ATC) System** – With this system green time calculation is made **instantly** based on prefixed delay minimizing algorithm
  - **Adaptive/Self Optimizing Traffic Control System** – With this system green time calculation is made **beforehand** using smart prediction model. It uses artificial intelligence (AI) to acquire knowledge and to refine existing prediction model.

## Isolated Traffic Signal Design

### Terminology

- **Signal sequence** – Green -> Amber -> Red -> Red/Amber
- **Phase** - That part of a cycle allocated to a stream or combination of two or more streams having the right of way simultaneously.
- **Filter signals** - it is mounted alongside the main signals to permit movement of vehicles in the direction shown by the green arrow even though the main signal is showing red.
- **Amber period/Clearance time (a)** - to allow vehicles to clear the junction. Usually 3 secs; ù high speeds junction 3-6 secs.
- **Inter-green period (I)** - the time from the end of the green period to the phase losing right-of-way to the beginning of the green period of the phase gaining right-of-way.
- **Optimum cycle length (C<sub>o</sub>)** - the cycle time which gives the least average delay to all vehicles using the intersection
- **Lost time (l)** - the time which is effectively lost to traffic movement in a phase because of starting delays and the falling-off discharge rate during the amber period.
- **Effective green time (g)** - the time during the cycle when traffic flows freely discharge through the green aspect at the maximum rate; it is the sum of the green period and the amber period less the lost time for the particular phase
- **All-red period** - a red period between the amber and red/amber shown to all approaches in order to allow vehicles to clear the junction safely before starting of the next phase: it is usually needed:
  - when junction is large
  - when there are slow moving vehicles in the traffic stream
  - when there are right turning vehicles left over at the end of the phase
  - when pedestrian movements are high in all directions and demand "pedestrian only" phase
- **Saturation flow (S)** - the maximum rate of discharge for a particular approach.

### Important Relationships

- Cycle time,  $C = \int (s, q, L)$ ; where, s = saturation flow/capacity; q = arrival flow/demand; L = lost times
- Intergreen,  $I = a + \text{all-red}$
- Cycle time,  $C = \sum G + \sum I$
- green period,  $G = g + L_i + L_f$ ; where, g = Effective green; L<sub>i</sub>, L<sub>f</sub> = initial and final lost time
- Total lost time/cycle,  $L = \sum \text{all-red} + \sum \text{lost time}$   
 $= \sum (I - a) + \sum (L_i + L_f)$
- Right-of-way  $= G + A = g + \text{lost time}$
- Maximum/dominant ratio of flow (q) to saturation flow (s) for a given phase of critical lane,  $y = q/s$
- Optimum cycle,  $C_o = (1.5 L + 5)/(1 - Y)$  in seconds; where,  $Y = y_1 + y_2 \dots y_n$ ; n = total no. of phase in cycle
- For optimum conditions,  
 Green time split:  $g_1/g_2 = y_1/y_2 = (C_o - L)/Y$

### Local Problems

- No. standard for signal setting & design:
- Set at far away from the intersections and encourage drivers to stop beyond the signal mast.
- Signals are installed even where they are not warranted.
- Signal light size (lens dia.) and lumination is inadequate.
- Cycle times and phasing are judgment based; amber clearance phases are short and inadequate for safe rickshaw clearance and above all a single timing plan is maintained throughout the day.
- Traditionally, drivers watch the policeman rather than the signals.
- Un-enforced signals discourages drivers compliance in general and thereby weakening the overall level of respect for traffic signals.

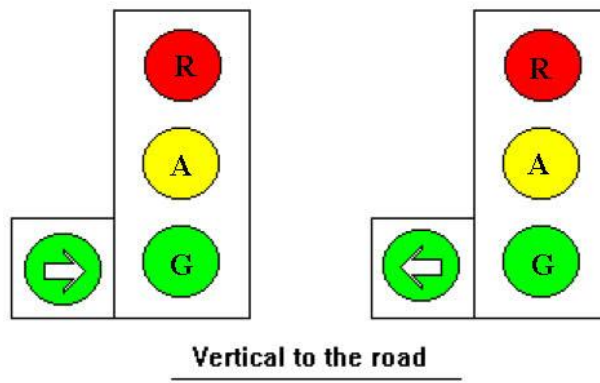
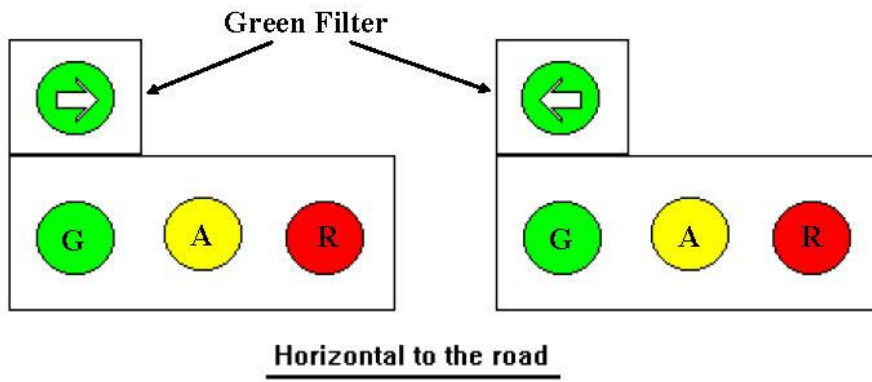
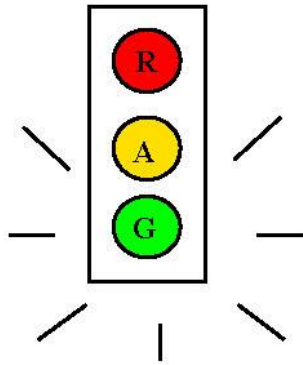

**PLACEMENT OF SIGNALS PROPOSED BY BRTA**

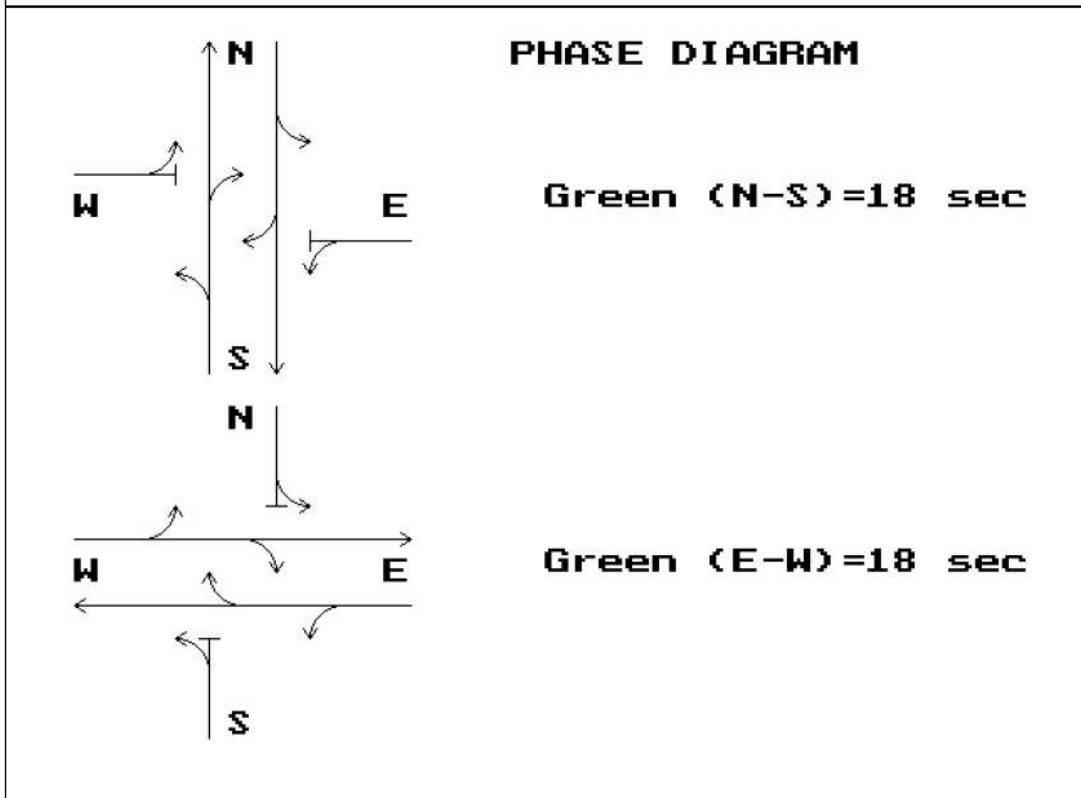
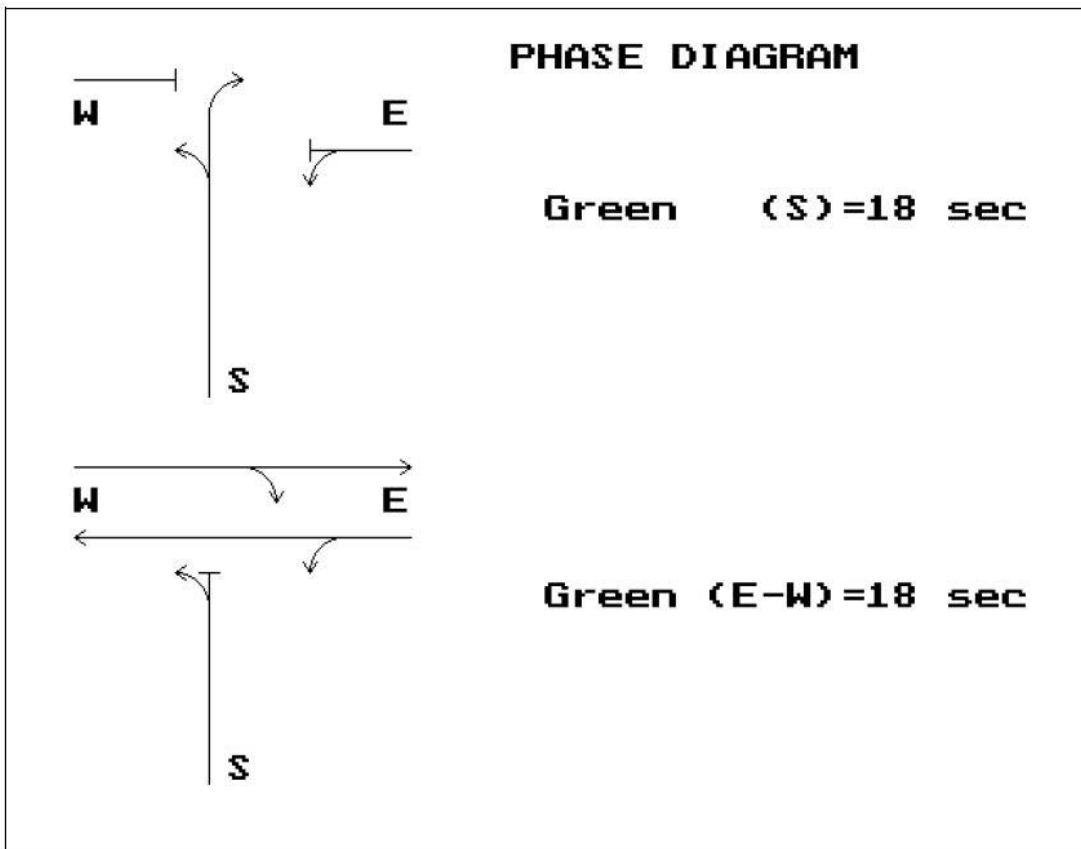

**TRAFFIC MOVEMENTS IN A TWO-PHASE SYSTEM**

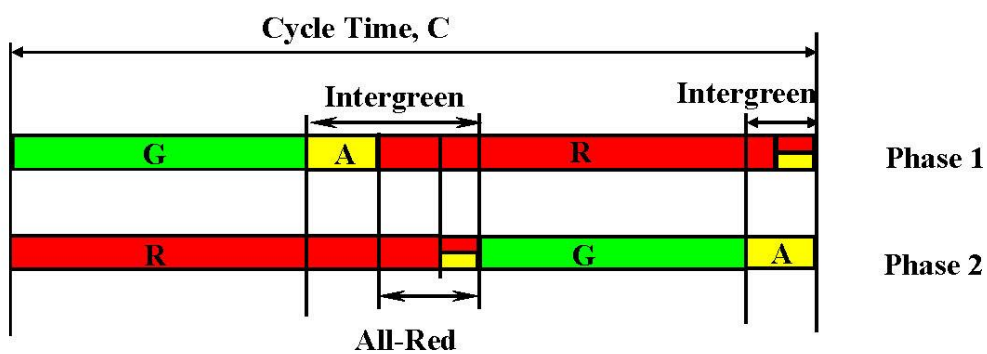
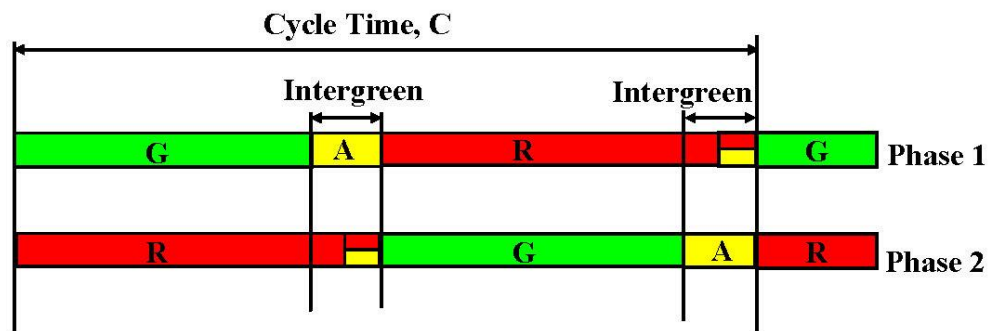

EXAMPLE OF INTERGREEN & ALL-RED PERIODS

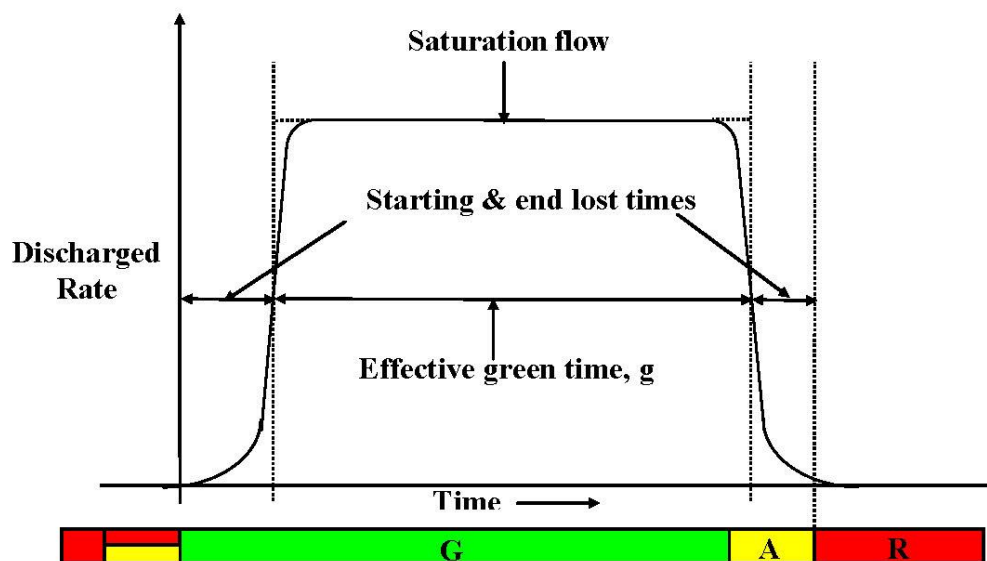
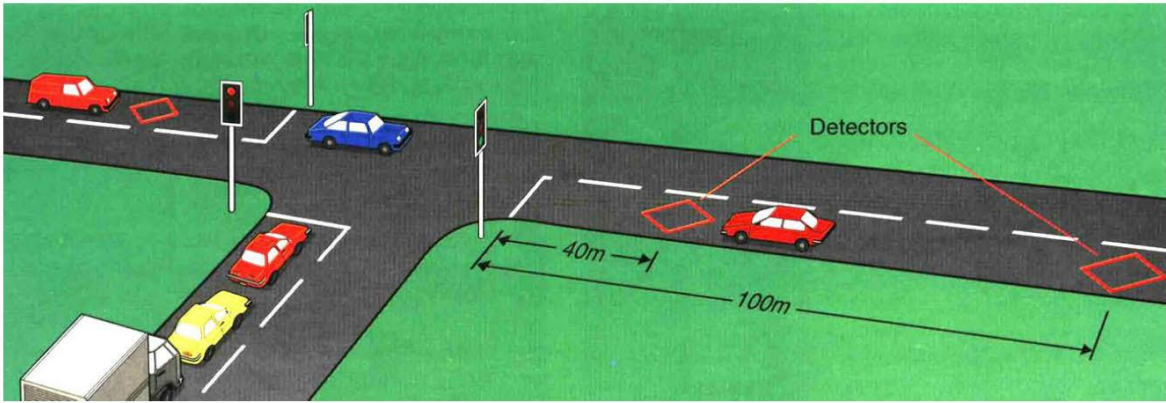

Illustration of saturation flow and lost times at traffic signals



Modern Trend



- ❑ For greater brightness use of LED/Fiber optic cluster instead of single incandescent based lighting system
- ❑ Display of digital clock signal along with signal (Count Down)
- ❑ Increasing use of adaptive/ self optimizing signal controller



ISO 9001 quality, modular design, low energy consumption, low maintenance, superior light intensity, clear symbol display, longevity, reliability

Electronic Regulatory  
time control of  
turning restric-

[www.lta.gov.sg](http://www.lta.gov.sg)  
[www.stee.st.com.sg](http://www.stee.st.com.sg)

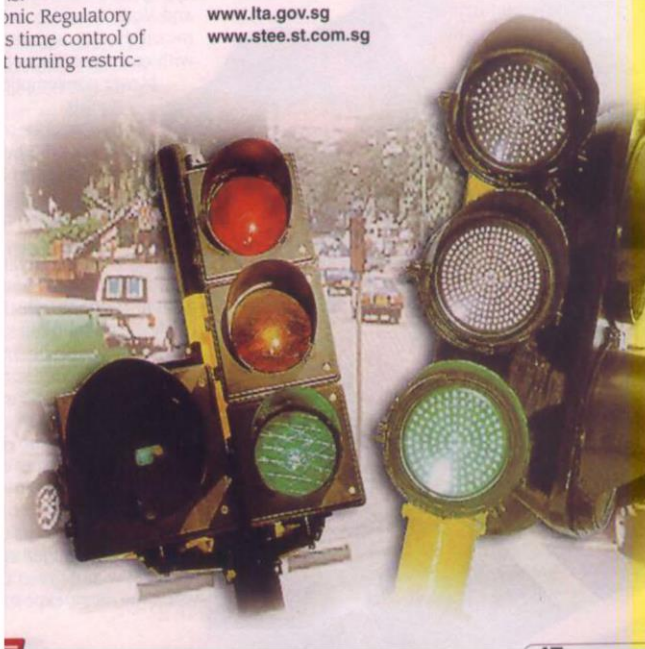

Hewlett Packard's white LEDs can be used in VMS and for emergency lighting



### Problem 1:

Design a two-phase signal of an isolated cross-junction for the following data:

Amber (a) in sec	3			
Red-Amber in sec	2			
	N-S	E-W		
Inter green, (i) in sec	6	7		
Lost time, (l) in sec	3	2		
	North	South	East	West
Arrival Flow (pcu/hr)	400	450	560	458
Sat. flow (pcu/hr)	1800	1780	1850	1780

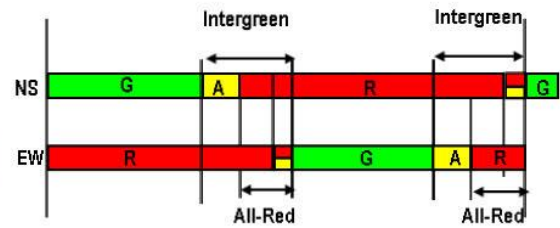

### Solution

	North	South	East	West
$y = \text{flow}/\text{sat. flow} =$	0.22	0.25	0.30	0.26
$y_{\text{dominating}} =$		0.25		0.30
$Y = y_{\text{NS}} + y_{\text{EW}} =$	0.56			
$L = \text{all red} + \text{green-ends lost times} = \text{sum}(i-a) + \text{sum}(l)$	$= 3 + 4 + 3 + 2 = 12 \text{ sec}$			
Optimum cycle time, $C_0 = [1.5 L + 5]/[1 - Y]$	$= [1.5 * 12 + 5]/[1 - 0.56] = 53 \text{ sec}$			
Total effective green time, $C_0 - L$	$= 53 - 12 = 41 \text{ sec}$			
Effective green for NS arm, $g_{\text{NS}} = y_{\text{NS}} * (C_0 - L) / Y$	$= 19 \text{ sec}$			
Effective green for EW arm, $g_{\text{EW}} = y_{\text{EW}} * (C_0 - L) / Y$	$= 22 \text{ sec}$			
Green + Amber period for NS arm, $g_{\text{NS}} + l$	$= 22 \text{ sec}$			
Green + Amber period for EW arm, $g_{\text{EW}} + l$	$= 24 \text{ sec}$			

$G_{\text{NS}} =$	19 s
Inter-green, NS =	6 s
$G_{\text{EW}} =$	21 s
Inter-green, EW =	7 s
Cycle time, $C_0 =$	53 s

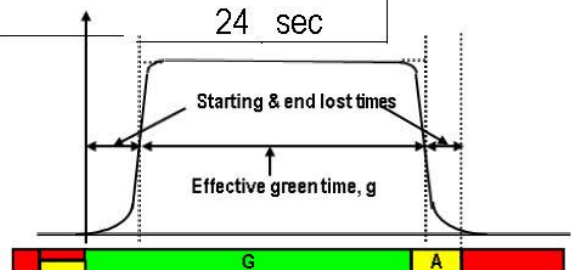

**Problem 2:**

Design a two-phase signal of an isolated cross-junction for the following data:

Amber (a) in sec	3			
Red-Amber in sec	2			
	N-S	E-W		
Inter green, (i) in sec	9	6		
Lost time, (l) in sec	3	2		
	North	South	East	West
Arrival Flow (pcu/hr)	550	650	900	800
Sat. flow (pcu/hr)	2200	2300	2800	3000

**Solution**

	North	South	East	West
$y = \text{flow}/\text{sat. flow} =$	0.25	0.28	0.32	0.27
$y_{\text{dominating}} =$		0.28		0.32
$Y = y_{\text{NS}} + y_{\text{EW}} =$	0.60			
L = all red + green-ends lost times = $\text{sum}(i-a) + \text{sum}(l)$				
				$= 6 + 3 + 3 + 2 =$
				14 sec
Optimum cycle time, $C_0 = [1.5 L + 5]/[1-Y] = [1.5 * 14 + 5]/[1 - 0.6]$				
				$=$ 66 sec
Total effective green time, $C_0 - L = 66 - 14 =$ 52 sec				
Effective green for NS arm, $g_{\text{NS}} = y_{\text{NS}} * (C_0 - L) / Y =$ 24 sec				
Effective green for EW arm, $g_{\text{EW}} = y_{\text{EW}} * (C_0 - L) / Y =$ 28 sec				
Green + Amber period for NS arm = $g_{\text{NS}} + l =$ 27 sec				
Green + Amber period for EW arm = $g_{\text{EW}} + l =$ 30 sec				

$G_{\text{NS}} =$	24 s
Inter-green, NS =	9 s
$G_{\text{EW}} =$	27 s
Inter-green, EW =	6 s
Cycle time, $C_0 =$	66 s

### Bar Diagram: Problem 1

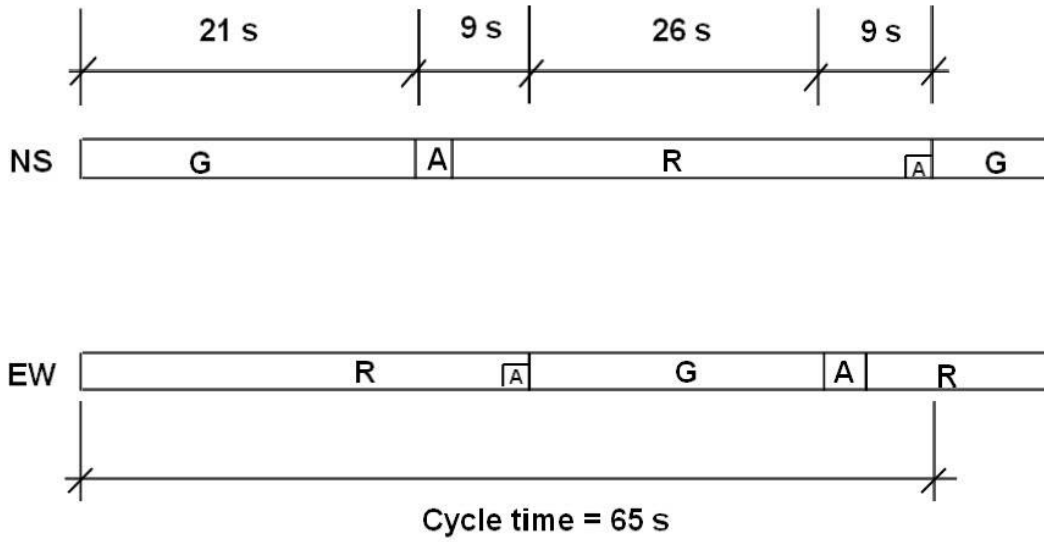

### Bar Diagram: Problem 2

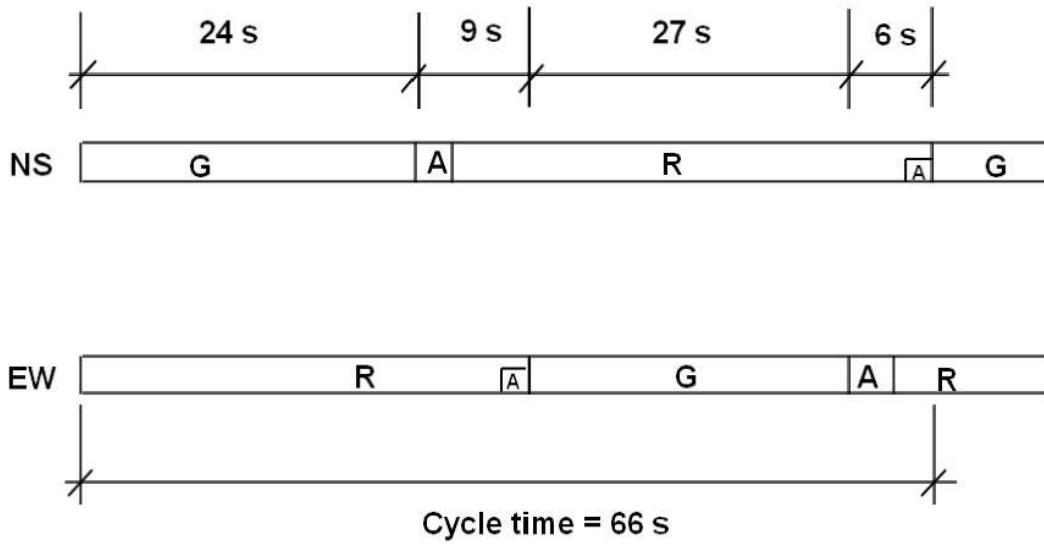

## STREET LIGHTING

### Introduction

- Perception requires greater time at low level of illumination
- Good visibility is a prerequisite to good traffic operation
- For night driving on roads, although all the motor vehicles have their own head lights which are quite sufficient, still adequate lighting on roads is essential for other road users viz. non-motorized vehicles (cycles, rickshaws, carts etc.), pedestrian – who have not their own lights
- A large proportion of the road accidents are caused in the night and one of the main reasons is the insufficient lighting
- In the absence of street light, drivers are forced to use dip-beam of head-lights – which causes glaring problem and often lead to severe accidents

### Objectives/Possible Benefits



Adequate street lighting -

- Enable road users to see clearly the roadway
- Make drivers confident in their maneuvers
- Encourages use of full roadway width
- Reduces use of dip-beam
- Reduces night time crime
- Improves personal security
- Promotes business

### Key Locations: Where Needed Adequate Street Lighting

Following locations/objects need more lights than that of straight roads

- where there are high proportions of pedestrians, cyclists or other poorly lit road users including animals
- intersections where both vehicular and pedestrian flow is high
- sharp bend, summit curves, tunnels pedestrian crossing areas, bridge sites, level crossings, other bottlenecks/places where there are restraints on traffic movements etc.
- hazardous objects like – road humps, channelizing islands etc.

### Arrangement/Layout of Street Lighting

- Single side
- Both sides
  - Staggered
  - Opposite
- Central
  - One head/arm
  - Two heads/double arms

### Types of Light Sources/Lamps

- Tungsten lighting/incandescent filament
- Tubular fluorescent
- Sodium lighting (low pressure vapor)
- Mercury lighting (vapor)

### Installation Requirements

To get uniform lit road surface, the following issues should be considered carefully:

- Mounting height
- Spacing
- Overhang
- Luminous intensity/brightness
- Surface type

## Design of Street Lighting

Design means fixing spacing and arrangement of lighting post.

### a) Determination of spacing

$$\begin{aligned}\text{Average pavement illumination} &= \text{Total effective illumination/Total area to be illuminate} \\ &= (L \times C_u)/(S \times W)\end{aligned}$$

Where;

- L = Lumen output of light source (strength of source)
- $C_u$  = Co-efficient of utilization (i.e. effective lumen of light on the pavement, which depends on the ratio of road width and mounting height)
- S = Spacing of light post
- W = Width of pavement

### **Procedure to find different design parameters**

- Actual average illumination = required illumination x pavement reflection factor**
- Use Table 1 and 2 to find out actual average illumination for
  - average illumination requirement and
  - pavement reflectance
- L (for particular source) = efficiency x total wattage**
- Use Table 3 to calculate lumen output, L for
  - type of source (fluorescent, sodium, mercury etc.)
  - wattage of source
  - its lighting efficiency in lumen/watt
- Actual utilization factor,  $C_u$  = utilization factor \* maintenance factor**
- Use Figure – 1 to find out effective utilization factor,  $C_u$  for
  - road width/post height ratio and
  - maintenance factor

### b) Arrangement/Layout of Street Lighting

Use Table 4 to select lighting layout

## Problems

An urban secondary road, with 50ft pavement width having a reflectance of 10%, carries a maximum of 1000 vph at night-time in both directions. Design lighting system of the road considering sodium light source with mounting height of 40ft and a maintenance factor of 0.8. Draw the lighting layout.

## Solution

### **i) Actual Average Illumination (AAI):**

From Table – 1; average recommended illumination = 0.8 L/ft<sup>2</sup>

From Table – 2; adjustment factor for surface reflectance = 1

Therefore, AAI = 0.8 x 1 = 0.8

### **ii) Lumen Output of Light Source**

Taking: Efficiency of light = 100 lumens/watt

Wattage = 150 watts

Lumen Output = Source efficiency x wattage = 100 x 150 = 15,000 Lumen

From Figure 1; for ratio = width/height = 50/40 = 1.25;  $C_u$  = 0.35

Effective  $C_u$  = 0.35 x maintenance factor = 0.35 x 0.8 = 0.28

As we know, AAI = (Lumen Output x  $C_u$ )/(Spacing x width of pavement)

Therefore, Spacing = (15000 x 0.28)/(0.8 x 50) = 105ft

### **Proposed Lighting Layout:**

Considering the width of pavement (SEE Table 1), it is proposed that the lighting posts would be placed on both sides of the road in staggered arrangement with post -

- Spacing = 130 ft;
- Mounting height = 40 ft;
- Overhang = 10 ft

TABLE 1 RECOMMENDED AVERAGE ILLUMINATION (LUMENS/FT<sup>2</sup>)

Pedestrian traffic <sup>(1)</sup>	Vehicular traffic <sup>(2)</sup> (vph)			
	Very light (< 150 vph)	Light (150 – 500 vph)	Medium (500 – 1,200 vph)	Heavy (> 1,200 vph)
Heavy	-	0.8	1.0	1.2
Medium	-	0.6	0.8	1.0
Light	0.2	0.4	0.6	0.8

Notes: (1) Heavy: As on main business street  
 Medium: As on secondary business streets  
 Light: As on local streets  
 (2) Night hour flow in both directions

TABLE 2 ADJUSTMENT FACTORS FOR RECOMMENDED AVERAGE ILLUMINATION VALUES

Surface Reflectance	Adjustment Factors
3 % or less	1.5
10%	1.0
20% or more	0.75

TABLE 3 LIGHTING SOURCE CHARACTERISTICS

Source Types	Expected Life (hrs)	Lighting Efficiency (Lumens/Watt)	Wattage (Watt)
Tungsten	1000	8 – 14	Up to 1000
Fluorescent	6000	50 – 75	Up to 250
Sodium	6000	100 – 120	Up to 160
Mercury	7500	20 – 60	Up to 400

FIGURE 1 CO-EFFICIENT OF UTILIZATION CURVES (FOR LIGHT DISTRIBUTION TYPE III)

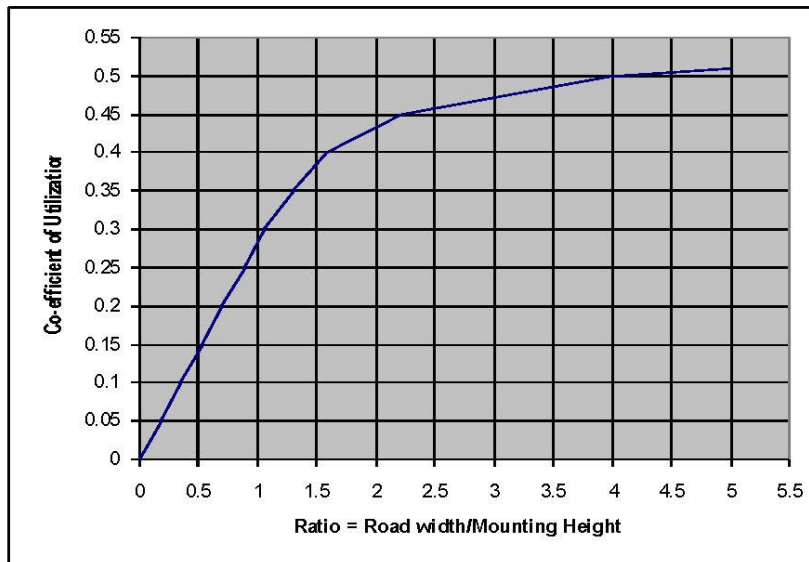

Note: Due to poor maintenance, the actual co-efficient of utilization is reduced by a factor usually 0.8 (i.e. taken as 80%).

TABLE 4 RECOMMENDED ARRANGEMENT OF STREET LIGHTING

Type of Arrangement	Pavement Width
One side	Width ≤ 30ft
Both sides – Staggered	30ft > Width ≤ 60ft
Both sides – Opposite	Width > 60ft



## TERMINALS

### Background



While in motion, larger sized vehicles viz. buses/trucks cause significant effects on traffic operation – as they

- are slow
- occupy large road space
- have poor maneuver capability
- require large turning radius
- take longer time for loading and unloading

Moreover, uncontrolled parking of these empty vehicles has many adverse effects on traffic operation. In this regard, terminal facility is considered as a measure of traffic control and management.

### Objectives

- To provide regulated loading/unloading and parking/ repairing facilities for buses
- To provide regulated parking/repairing facilities for empty trucks

## BUS TERMINALS

### Introduction

- Terminals provide bus layover areas, where passengers loading/unloading are taken place
- In a town, it is desirable to provide a properly designed bus terminal to handle exclusively long distance inter-city bus traffic
- The terminals should be planned for the anticipated future traffic in the design year

### Location

- Bus terminals should preferably be outside the congested portions of the town (out skirt of the city)
- If a town has ring road, ideal location in many cases is on the ring road

### Regulations

To ensure proper functioning and effective use, terminals should

- be regulated and controlled properly
- have queue discipline
- maintain strict scheduling and ensure minimum layover at the queue
- not be allowed to use for repair purposes

### Terminal Requirements

- Terminal should be planned in such a way that one-way circulation of buses is achieved
- Due to heavy passengers activities, measure (barrier, sufficient waiting place, etc.) should be taken to ensure passengers movements not conflicts with vehicular movements
- The platforms, where passengers wait should be raised
- Provision for facilities such as cafeteria, book-stalls, phone booth, toilets etc. should be provided
- Terminals should have feeder/transit facilities – scheduled bus, train etc. services (i.e. easily accessible)
- Parking facilities for cars, taxis, par-transit etc. should be provided liberally
- Should have separate/isolated space for long time stay, fuelling facilities, workshop etc.

## TRUCK TERMINALS (FOR COMMERCIAL/FREIGHT TRAFFIC)

### Introduction

- ❑ Loading and unloading of goods by trucks on the roadside makes demands upon the spaces, which are reserved for pedestrian as well as for moving vehicles
- ❑ The problem can be controlled by permitting loading and unloading
  - ❑ only between lean period or
  - ❑ permitting loading and unloading only at specific locations
- ❑ Empty trucks need spaces for parking – terminal is the best solution where repairing, waiting for assignment can be done without interrupting traffic movements
- ❑ Truck traffic needs control on
  - ❑ parking for empty vehicles and
  - ❑ loading/unloading areas and time of operation
- ❑ Terminal should be located at the fringes of the cities/on important arterial routes/close to major generators of commercial activities
- ❑ Should have ancillary facilities such as loading/unloading platform, weight bridge, storage, fuelling facilities, workshop etc. in addition to the parking area
- ❑ For single unit trucks – a bay size of 3.75m X 7.5m is adequate and about 600 – 750 trucks can be accommodated in a parking area of one hector

### Terminology



- ❑ **Terminal** - a place for the use of passengers joining or leaving a bus, ship etc. and freight loading/unloading of trucks.
- ❑ **Depot** - a place where buses/trucks are kept and repair.
- ❑ **Workshop** - where heavy repairs and jobs on vehicles are done .

### Bangladesh

#### Local Experiences

- ❑ Excessive layover/stopover make terminal inefficient
- ❑ Being used for repair and garage purposes
- ❑ Uncoordinated/unscheduled services (because of many bus owners)
- ❑ Poor queuing discipline
- ❑ Competition for attracting passengers (fighting for passenger)
- ❑ Drop-off/pick-up passengers at the entrance/exit of terminals
- ❑ Hoodliganism/trade union activities make terminal unsafe place for the passengers



## Street Lighting

Street Lighting



Street Lighting



Prof. Dr. Md. Shamsul Hoque, BUET

CE 351

## Street Lighting

### Introduction

- For night driving good visibility is a prerequisite for safer traffic operation
- Although all the motor vehicles have their own head lights, still adequate lighting is essential for other road users viz. NMV, pedestrian
- Perception requires greater time at low level of illumination
- A large proportion of the road accidents are caused in the night and one of the main reasons is the insufficient lighting
- Absence of street light, forced drivers to use high-beam of head-lights – which causes **glaring problem** and often lead to severe accidents



Prof. Dr. Md. Shamsul Hoque, BUET

CE 351

## Street Lighting

### Objectives/Possible Benefits

Adequate street lighting -

- Enable road users to see clearly the roadway
- Make drivers confident in their maneuvers
- Encourages use of full roadway width
- Reduces use of High-beam
- Reduces night time crime
- Improves personal security
- Promotes business



Prof. Dr. Md. Shamsul Hoque, BUET

CE 351

## Street Lighting

### Key Locations: Needed Adequate Street Lighting

Following locations/objects need more lights than that of straight roads -

- where there are high proportions of poorly lit road users viz. pedestrians, NMVs
- intersections where both vehicular and pedestrian flow are high
- hazardous sections like -  
roundabout, sharp bend, summit curves, bridge, tunnels, level crossings  
other bottlenecks/places where there are restraints on traffic movements etc.
- hazardous objects like – road humps, channelizing islands etc.



Prof. Dr. Md. Shamsul Hoque, BUET

CE 351

## Street Lighting

### Arrangement/Layout of Street Lighting



- Single side
- Both sides
  - Staggered
  - Opposite
- Central
- Single post single arm
- Single post double arms
- Single post multiple arms
- Single post with flower arrangement



### Types of Light Sources/Lamps



- Tungsten lighting/incandescent filament
- Tubular fluorescent
- Sodium lighting (low pressure vapor)
- Mercury lighting (vapor)



Prof. Dr. Md. Shamsul Hoque, BUET

CE 351

## Street Lighting

### Installation Requirements

To get uniform lit road surface, the following issues should be considered carefully:

- Mounting height
- Spacing
- Overhang
- Luminous intensity/brightness
- Surface type

**Design of Street Lighting** - means fixing spacing & arrangement of lighting post.

a) Determination of spacing

$$\text{Avg. pavt. illumination} = \frac{\text{Total effective illumination}}{\text{Total area to be illuminate}} = \frac{(L \times C_u)}{(S \times W)}$$

Where;

L = Lumen output of light source (strength of source)

C<sub>u</sub> = Co-efficient of utilization

S = Spacing of light post; W = Width of pavement

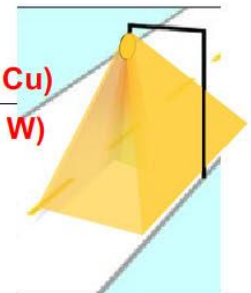

Prof. Dr. Md. Shamsul Hoque, BUET

CE 351

## Street Lighting

TABLE 1 RECOMMENDED AVERAGE ILLUMINATION (LUMENS/FT<sup>2</sup>)

Pedestrian traffic <sup>(1)</sup>	Vehicular traffic <sup>(2)</sup> (vph)			
	Very light (<150 vph)	Light (150 – 500 vph)	Medium (500 – 1,200 vph)	Heavy (>1,200 vph)
Heavy	-	0.8	1.0	1.2
Medium	-	0.6	0.8	1.0
Light	0.2	0.4	0.6	0.8

Notes: (1) Heavy: As on main business street  
 Medium: As on secondary business streets  
 Light: As on local streets  
 (2) Night hour flow in both directions

TABLE 2 ADJUSTMENT FACTORS FOR RECOMMENDED AVERAGE ILLUMINATION VALUES

Surface Reflectance	Adjustment Factors
3 % or less	1.5
10%	1.0
20% or more	0.75

## Street Lighting

TABLE 3 LIGHTING SOURCE CHARACTERISTICS

Source Types	Expected Life (hrs)	Lighting Efficiency (Lumens/Watt)	Wattage (Watt)
Tungsten	1000	8 – 14	Up to 1000
Fluorescent	6000	50 – 75	Up to 250
Sodium	6000	100 – 120	Up to 160
Mercury	7500	20 – 60	Up to 400

## Street Lighting

FIGURE 1 CO-EFFICIENT OF UTILIZATION CURVES (FOR LIGHT DISTRIBUTION TYPE III)

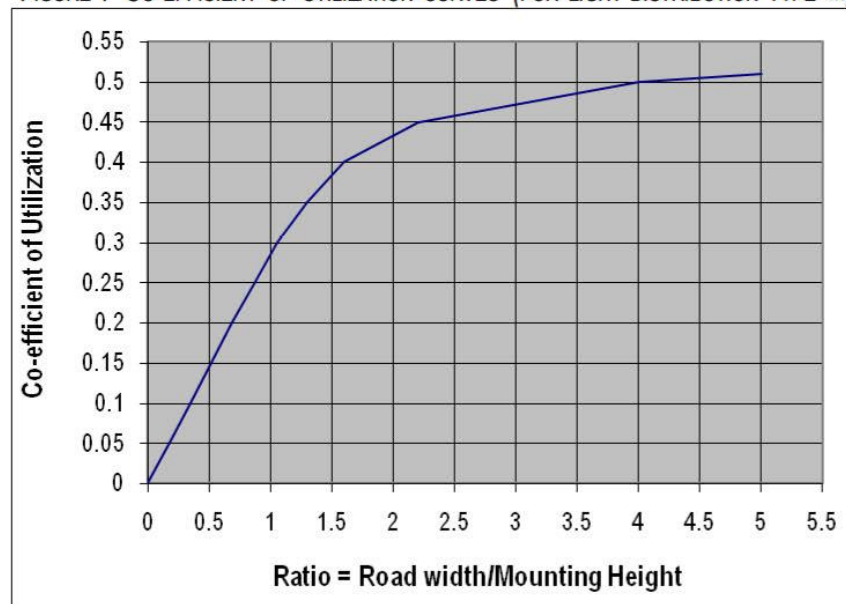

Note: Due to poor maintenance, the actual co-efficient of utilization is reduced by a factor usually 0.8 (i.e. taken as 80%).

## Street Lighting

### b) Arrangement/Layout of Street Lighting

TABLE 4 RECOMMENDED ARRANGEMENT OF STREET LIGHTING

Type of Arrangement	Pavement Width
One side	Width $\leq$ 30ft
Both sides – Staggered	30ft > Width $\leq$ 60ft
Both sides – Opposite	Width > 60ft

### Problems

An urban secondary road, with 50ft pavement width having a reflectance of 10%, carries a maximum of 1000 vph at night-time in both directions. Design lighting system of the road considering sodium light source with mounting height of 40ft and a maintenance factor of 0.8. Draw the lighting layout.

## Street Lighting

### Solution

Average Illumination (AAI):

From Table – 1; average recommended illumination = 0.8 L/ft<sup>2</sup>

From Table – 2; adjustment factor for surface reflectance = 1

Therefore, AAI = 0.8 x 1 = 0.8

Lumen Output of Light Source

Taking: Efficiency (Flat Deck) = 100 lumens/watt

Wattage = 150 watts

Total Output = Source efficiency x wattage

= 100 x 150 = 15,000 Lumen

From Figure 1; for ratio = width/height = 50/40 = 1.25;  $C_u = 0.35$

Effective  $C_u = 0.35 \times \text{maintenance factor} = 0.35 \times 0.8 = 0.28$

As we know,  $AAI = (\text{Lumen Output} \times C_u) / (\text{Spacing} \times \text{width of pavement})$

Therefore, Spacing =  $(15000 \times 0.28) / (0.8 \times 50) = 105\text{ft}$

Prof. Dr. Md. Shamsul Hoque, BUET

CE 351

## STREET LIGHTING

### Proposed Lighting Layout and Design:

Considering the width of pavement (SEE Table 4), it is proposed that the lighting posts would be placed on **both sides of the road in staggered** arrangement with post -

Spacing = 105 ft;

Mounting height = 40 ft;

Overhang = 10 ft

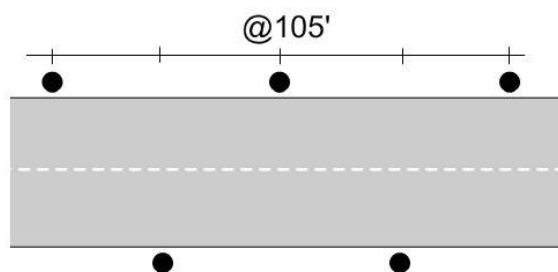

Plan : Both Staggered

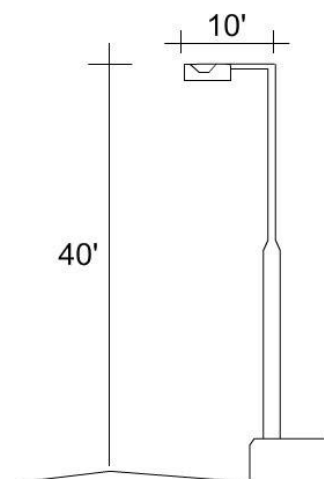

Elevation

Prof. Dr. Md. Shamsul Hoque, BUET

CE 351

## Terminals

Terminals



Terminals

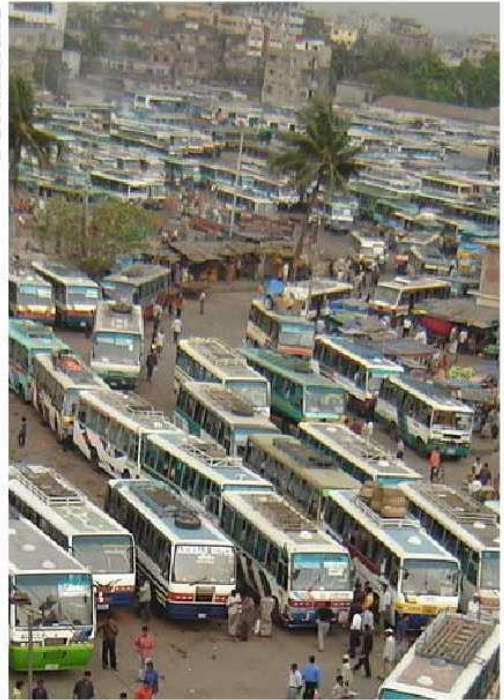

Prof. Dr. Md. Shamsul Hoque, BUET

CE 351

## Terminals

### Introduction

Larger sized veh(buses/trucks) cause significant effects on traffic operation – as they

- are slow
- occupy large road space
- have poor maneuver capability
- require large turning radius
- take longer time for loading and unloading



Terminal facility is considered as a measure of traffic control & management.

### Objectives

- To provide regulated loading/unloading and parking / repairing facilities for buses
- To provide regulated parking/repairing facilities for empty trucks

Prof. Dr. Md. Shamsul Hoque, BUET

CE 351

## Terminals

---

### BUS TERMINALS

#### Introduction

- T. provide bus layover & passengers loading/unloading facility
- In a town, it is desirable to provide a properly designed bus terminal to handle exclusively long distance inter-city bus traffic



#### Location

- Bus terminals should preferably be outside the congested portions of the town (out skirt of the city)
- If a town has ring road, ideal location in many cases is on the ring road

#### Regulations

To ensure proper functioning and effective use, terminals should

- be regulated and controlled properly
- have queue discipline
- maintain strict scheduling and ensure minimum layover at the queue
- not be allowed to use for repair purposes

## Terminals

---

### Terminal Requirements

- T. should be planned in such a way that 1-way circulation of buses is achieved
- Due to heavy passengers activities, measure should be taken to ensure passengers movements not conflicts with vehicular movements
- The platforms, where passengers wait should be raised
- Should have facilities such as cafeteria, book-stalls, phone booth, toilets etc.
- Terminals should have feeder/transit facilities – scheduled bus, train etc. services
- Parking facilities for cars, taxis, par-transit etc. should be provided liberally
- Should have /isolated space for long time stay, fuelling facilities, workshop etc



## Terminals

### TRUCK TERMINALS

- Roadside loading/unloading of goods affect both vehicular & pedestrian traffic
- Problem can be controlled by permitting loading/unloading
  - only between lean period or
  - permitting loading and unloading only at specific locations
- Terminal is the best solution where repairing, waiting for assignment can be done without interrupting traffic movements
- Terminal should be located at the fringes of the cities/on important arterial routes/close to major generators of commercial activities
- Should have ancillary facilities such as loading/unloading platform, weight bridge, storage, fuelling facilities, workshop etc.
- For single unit trucks – a bay size of 3.75m X 7.5m is adequate
- About 600-750 trucks can be accommodated in one hector land



Prof. Dr. Md. Shamsul Hoque, BUET

CE 351

## Terminals

### Terminology

- Terminal - a place for the use of passengers joining or leaving a bus, ship etc. and freight loading/unloading of trucks
- Depot - a place where buses/trucks are kept and repair
- Workshop - where heavy repairs and jobs on vehicles are done

### Local Situation

- Excessive layover/stopover make terminal inefficient
- T. being used for resting, repair and garage purposes i.e. as a depot & workshop
- Uncoordinated/unscheduled services (because of many bus owners)
- Terminal size become unusually large
- Poor queuing discipline
- Competition for attracting passengers (fighting for passenger)
- Drop-off/pick-up passengers at the entrance/exit of terminals
- Trade union activities make terminal unsafe place for the passengers



Prof. Dr. Md. Shamsul Hoque, BUET

CE 351

Organized Company Based Bus Operation System Need  
Smaller Sized Terminal

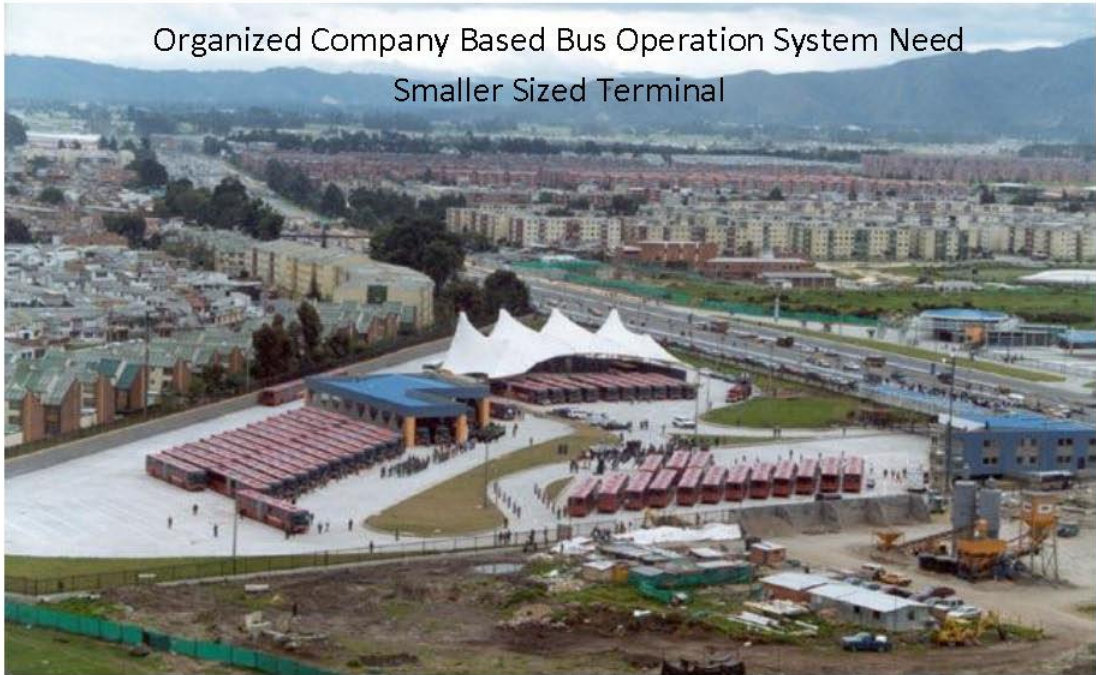

Disciplined Bus Parking

Nice Passenger Platform with Information System



## Unorganized Multi-owner Based Bus Operation



## Unorganized Multi-owner Based Bus System Demands Very Large Terminal



Unorganized Multi-owner Based Bus System Causes Indiscipline Terminal Operation



Uncontrolled On-Street Truck Parking Drastically Reduces Effective Width of Road

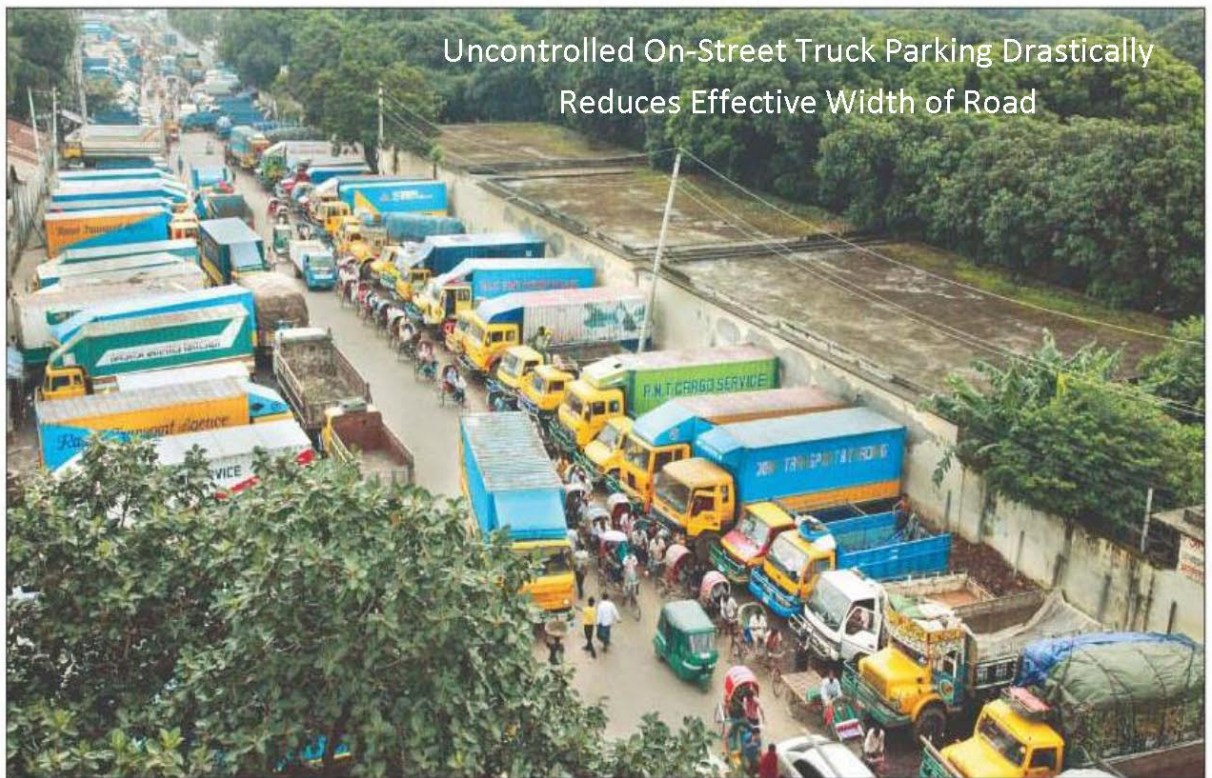



Day Time Entry Restrict without Truck Terminal Increases Road Side Frictions

**The End**

---

## Additional Slides

---

## CE 351: Transportation Engineering I: Transport & Traffic Design (for L4 T1; 3.00 Credit)

### Syllabus

---

#### Dr. Alamgir M. Hoque

- Introduction to transportation engineering;
- Development of transportation systems;
- Elements of transportation systems;
- Transportation in Bangladesh;
- Modal share

---

#### Dr. Hasib M. Ahsan

- Transport planning concepts;
- Collection, study and analysis of basic data;
- Highway location and surveys;
- Geometric design of highways:
- Element of design,
- Cross-section elements,
- Curves and sight distances,
- Road intersections

## CE 351: Transportation Engineering I: Transport & Traffic Design

### Dr. Shamsul Hoque

#### Traffic Engineering (TE):

- The road/traffic system,
- Vehicle and traffic characteristics;
- Traffic control devices;
- Traffic studies;
- Parking;
- Roadway lighting; and
- Terminals.

## CE 351: Transportation Engineering I: Transport & Traffic Design



### Class Distribution

Class 1 Introduction  
Class 2 Traffic Engineering  
Class 2 & 3 The Road/traffic System  
Class 3 & 4 Vehicle and Traffic Characteristics  
Class 5, 6, & 7 Traffic Studies

### Class Test 1

Class 8 & 9 Traffic Control Devices  
Class 10 & 11 Parking

### Class Test 2

Class 12 Lighting  
Class 13 Terminals  
Class 14 Overview



## CE 351: Transportation Engineering I: Transport & Traffic Design



### Reference Books:

- 
1. Kadiyali, L.R., "Traffic Engineering and Transport Planning", Latest Edition.
  2. Singh, G. C., "Highway Engineering", Latest Edition.
  3. Wright, P.H. and Paquette, R.J. "Highway Engineering", Sixth Edition, 1996.
  4. O'Flaherty, C.A., "Highways and Traffic", Volume 1, Second Edition, 1983.
  5. Matson, M.T. and Hurd, W.F., "Traffic Engineering", McGraw-Hill, 1955.
-

## Traffic Engineering



### Introduction :

Traffic engg. deals with the operational aspect of transportation engg.

It is the science of

- measuring traffic and travel, the study of basic laws relating to traffic flow and generation, and
- application of this knowledge to the professional practice of planning, designing, and operating traffic systems to achieve safe, efficient and convenient movement of persons and goods.



Prof. Dr. Md. Shamsul Hoque

## Traffic Engineering



### History

---

- Traffic Engineering as it is known today has evolved gradually with increase in traffic (veh.& ped.)
- Initially it was limited to application of simple rules and regulations such as left driving rule, road signs, marking, and intersection control by flag etc.
- Subsequent analysis of traffic operations and road accidents led to the realization the traffic regulations and other methods of traffic control should be based on proper **engineering studies**.



Prof. Dr. Md. Shamsul Hoque

## Traffic Engineering



### History *Contd.....*

- In consequence as extension of traffic regulations - many new traffic control and management techniques were devised viz. speed zoning, traffic signals, turn restrictions, parking restrictions, bus priorities, one-way street etc.
- Eventually it become evident that the planning and design of efficient road network largely depends upon the ***integrated land-use & transport policies*** and effective ***demand management*** (road pricing to control & distribute peak hours demand)



Prof. Dr. Md. Shamsul Hoque

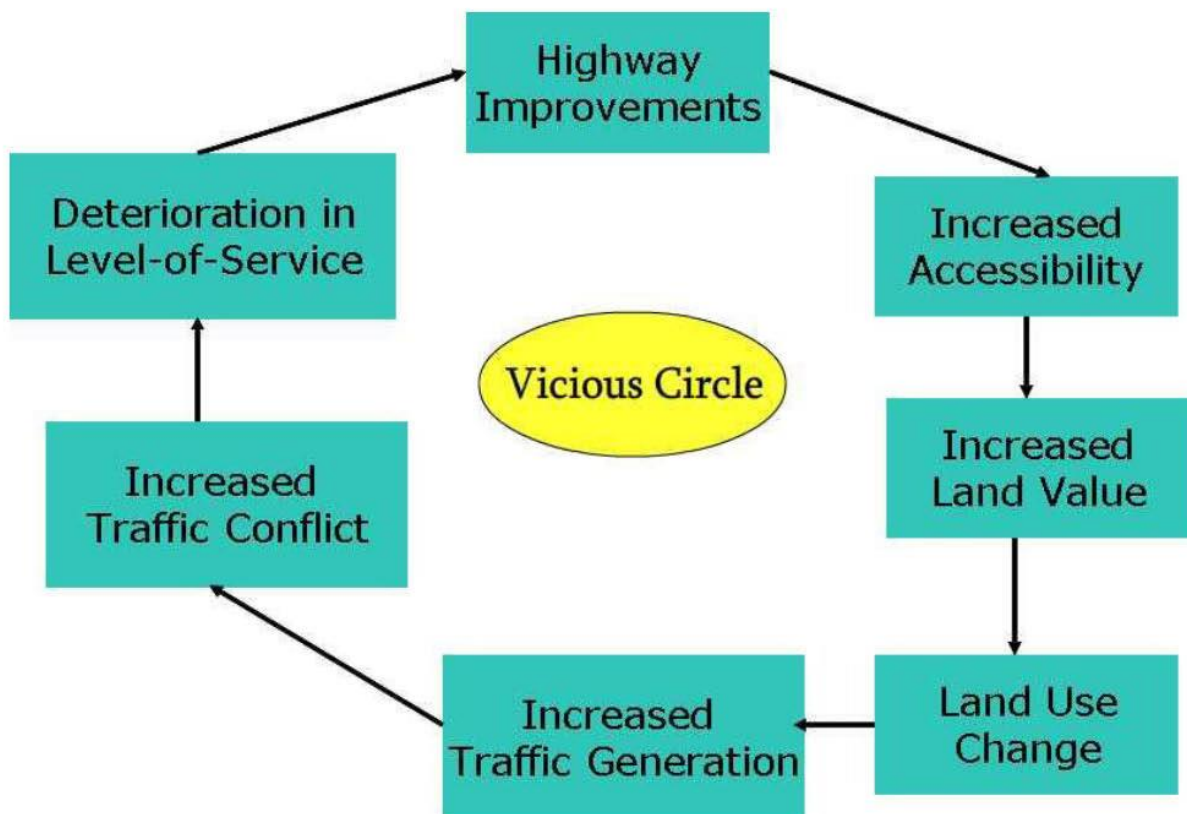

## Transportation-Land Use Cycle

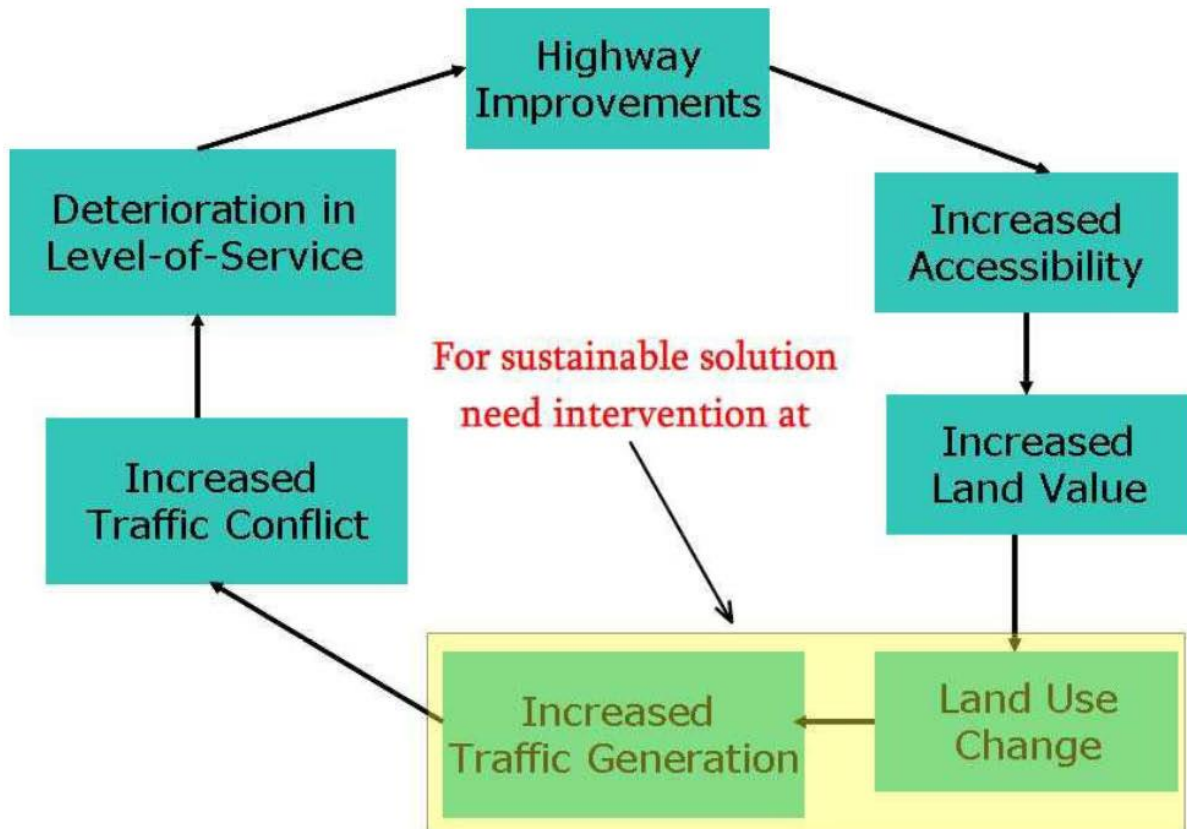

## Transportation-Land Use Cycle

CE - 351

### Traffic Engineering



#### History *Contd.....*

- **Modern traffic engineering measures** are mostly restrictive and dynamic in nature and largely depend on :
  - Public Transport Facilities and
  - Information Technology (IT).
- Side by side adhere TOD (Transit Oriented Development) approach



Prof. Dr. Md. Shamsul Hoque

## CONGESTION CAUSED BY SMALLER SIZED VEHICLES



*Prof. Dr. Md. Shamsul Hoque*



Karl Fjellstrom, ltdp-china.org

## Transit Oriented Development

## Traffic Engineering



### Traffic engineering includes :

- Studies and analysis of traffic characteristics and flow parameters
- Geometric design (mainly improvement)
- Planning of regulatory measures
- Design and application of control devices
- Functional planning of road network



Prof. Dr. Md. Shamsul Hoque

## Traffic Engineering



### Why TE is so essential now-a-days?

Because of

- Increased urbanization process
- Increased traffic demand - phenomenal growth in traffic
- Congestion become chronic in every where
- Difficulties in expanding roadway facilities within built up areas

Therefore, there is a need to maximize the utilization of existing facilities by better traffic management and control measures. Moreover, there is a need to tackle :

- Increased air pollution
- Increased accident numbers
- Increased road network



Prof. Dr. Md. Shamsul Hoque

## Traffic Engineering

For better management of road network, the traffic engineers must know the common causes of congestion and accident.

**Bottlenecks** - sources of flow interruption; which causes sudden decrease of vehicles' speed and roadway capacity. Bottlenecks are the main causes of congestion.

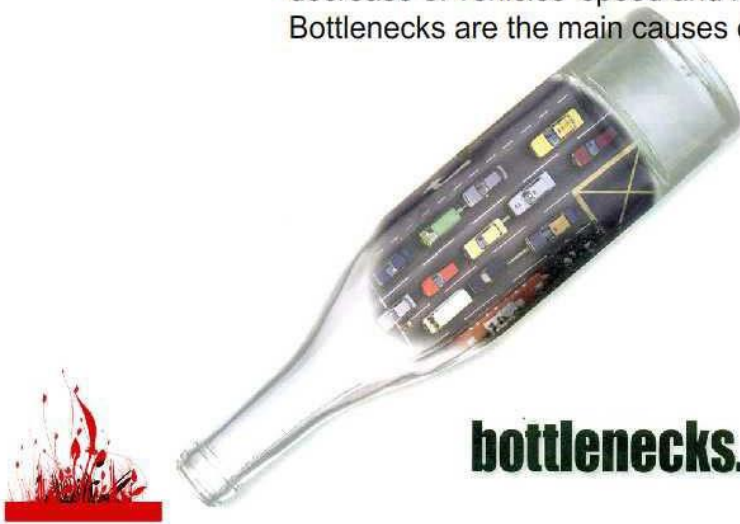

Prof. Dr. Md. Shamsul Hoque

## Traffic Engineering

### Common bottlenecks or Causes of Congestion

#### Geometric Factors

- road intersections
- railway crossings
- narrow road/bridge/culverts
- inconsistent roadway width
- poor turning radius/sharp bend

#### Road Side Frictions

- scattered parking/non-motor activities along road
- frequent side roads entries
- bus stops/parking near junctions
- road side cut/unfinished repair of road side pavement
- poor drainage facility

Prof. Dr. Md. Shamsul Hoque



**Junctions act as Bottleneck and causes Chronic Congestion**



**Road Side Frictions**

# Traffic Engineering

## Common bottlenecks or Causes of Congestion

Contd...

### Poor Roadway Environment

- poor road discipline
- uncontrolled pedestrian crossing
- poor road surface condition
- speed breaker
- poor lighting

### Traffic Internal Frictions

- due to mixed or heterogeneous traffic stream
- if traffic demand (volume) > roadway capacity
- due to undue conflicts with the turning movements



Prof. Dr. Md. Shamsul Hoque





CE - 351

## Traffic Engineering

### Safety problems arise mainly

- at intersections
- where pedestrian activities are high
- along on-street parking
- at blind spots - viz. bends, spots with poor sight distance/lighting facilities etc.

due to:

- poor road surface condition
- faulty road geometry
- poor traffic operating condition - lack of traffic control devices
- drivers faults
- mechanical failure



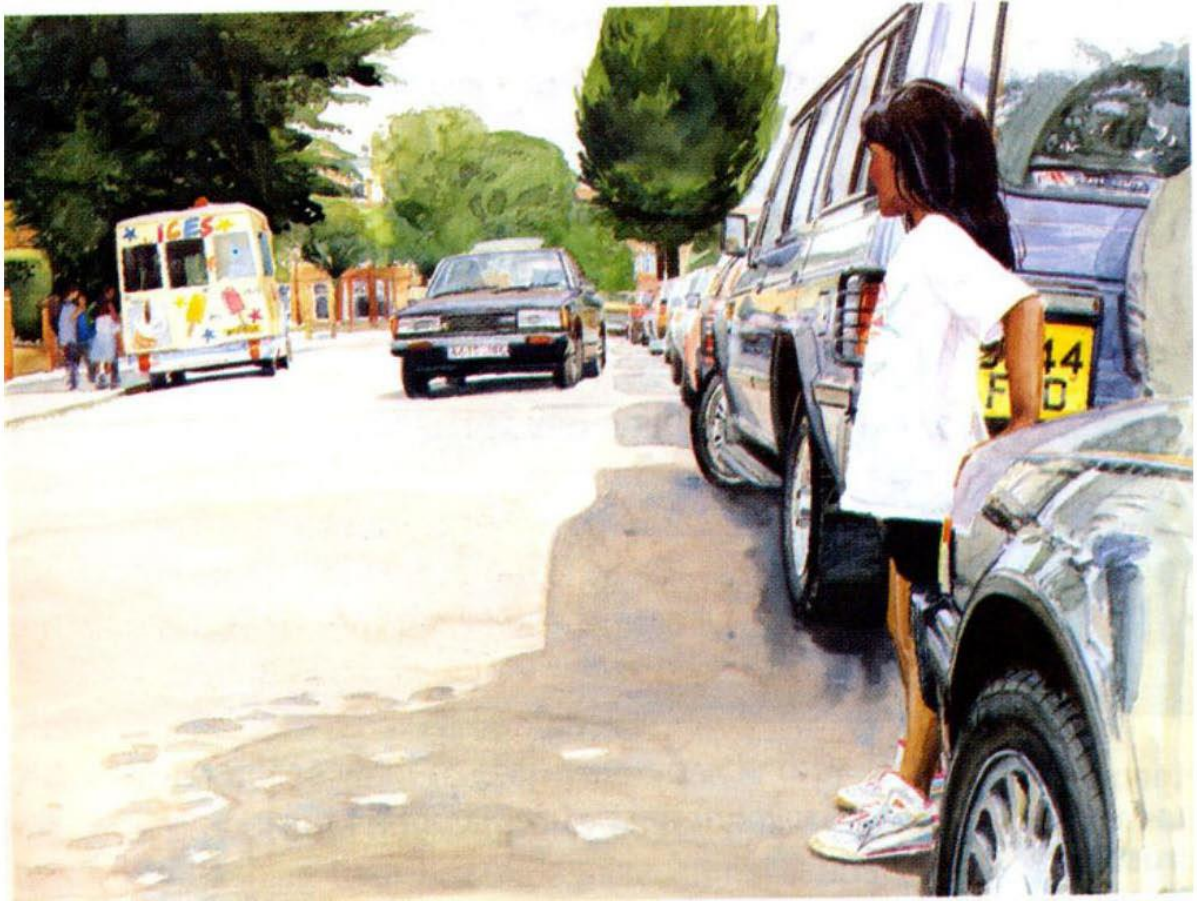

**Obstructed Vision**

CE - 351

## Traffic Engineering

### Traffic Engineering Tools

#### Physical tools/measures

##### A. To control vehicular movements

- road signals/signs/markings
- road divider/channelisation/island
- exclusive turning lane - flaring/widening of intersection
- service road/ring road/by-pass
- bus lay-by
- speed breakers
- segregated bus lane
- segregated non-motorized vehicle (NMV) lane
- grade separation etc.



*Prof. Dr. Md. Shamsul Hoque*



**Road with Channelized Footpath and Appropriate Carriageway Signs and Markings**



**Channelized Intersection with Exclusive Left Turning Lane**



Road with Service/Frontage Road to Compartmentalize Local Traffic from Through Traffic



Road with Nice Bus Lay-by/Pullout

# Traffic Engineering

## Physical tools/measures

Contd....

### B. To control standing vehicles

- on/off street parking
- off street load/unloading for freight vehicles
- park & ride facilities
- terminals etc.

### C. To control pedestrian movement

- guard rail/median/pedestrian barriers
- raised side walk/footpath
- cross walk
  - un-signalized – Zebra crossing
  - signalized (time separated/sharing)
  - grade separated (space separated)
    - underpass
    - overpass

Prof. Dr. Md. Shamsul Hoque



Planned On/Off Street Parking Facilities



**Park and Ride Facility**



**Organized Bike Facility to facilitate Mass Transit System**



**Pedestrian Guard/Picket Rail**



**Road with Nice Bus Lay-By and New Jersey Median Barrier**



**Road Side Continuous W-Beam Safety Barrier**



**Guide Posts with Retro-Reflective Object Markings to Aid Nighttime Driving**

# Traffic Engineering



---

## Regulatory measures

- banning right turn
  - one-way operation
  - tidal flow operation
  - junction clear-way
  - speed control
  - parking control
  - access control
  - road pricing etc.
- 



Prof. Dr. Md. Shamsul Hoque



Oneway Road Operation



Intersect with Junction Clearway (Double Yellow Line) and Box Operation



Traffic Operation with Electronic Road Pricing Measure

## Transportation System (যাতায়াত ব্যবস্থা)

Traditional Transportation: Physical movement of people & goods/freight from one place to another  
Modern Transportation : Virtual movement of information/documents



## Communication System (যোগাযোগ ব্যবস্থা)

The system which includes both physical and virtual movements

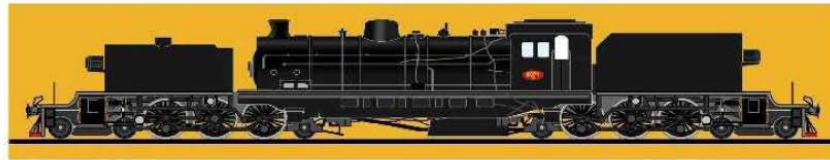

Prof. Dr. Md. Shamsul Hoque

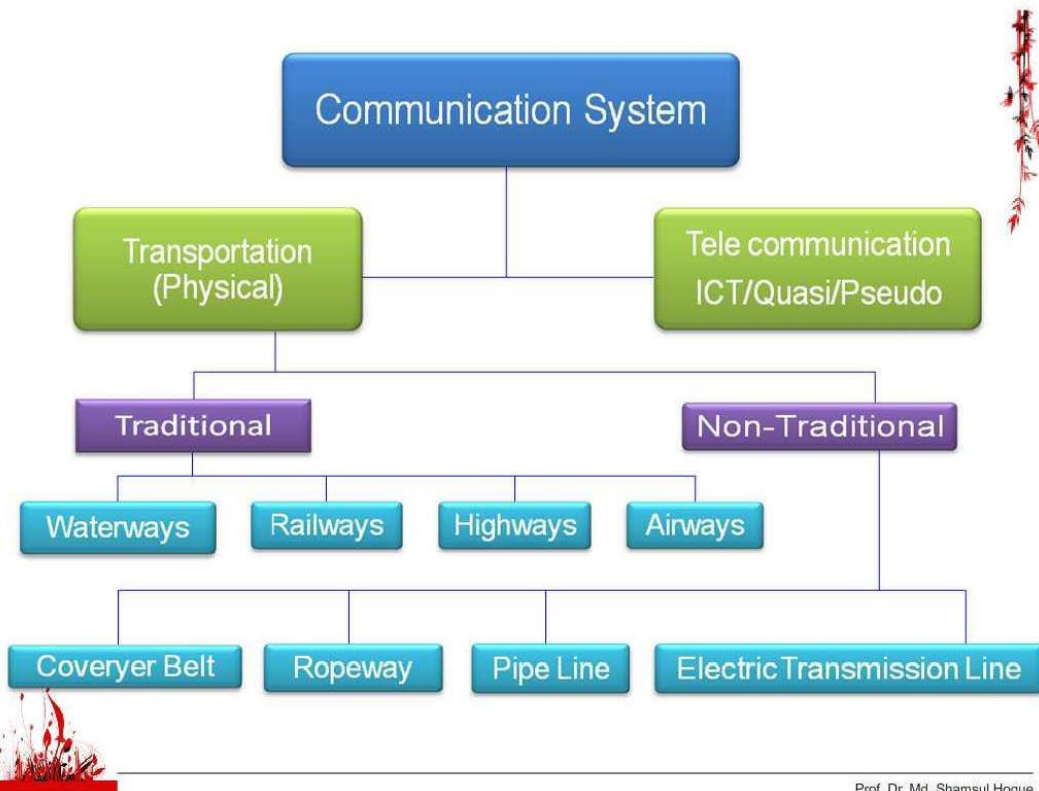

Prof. Dr. Md. Shamsul Hoque



## Waterways



A crane moves a container at Chittagong Port. With 8.5 percent annual growth, the seaport's two-thirds capacity is now being utilised.

STAR



## Inland Container Terminal



## Multimodal Container Service



**Bangladesh train with just a few spare seats**



## Highways



**Road based Bus Rapid Transit (BRT)**



**Road based Elevated Mass Rapid Transit (MRT)**



## Airways



**Conveyer Belt**



**Ropeway**



**Pipeline**



**Electric Transmission Line**



## Multimodal Transport System

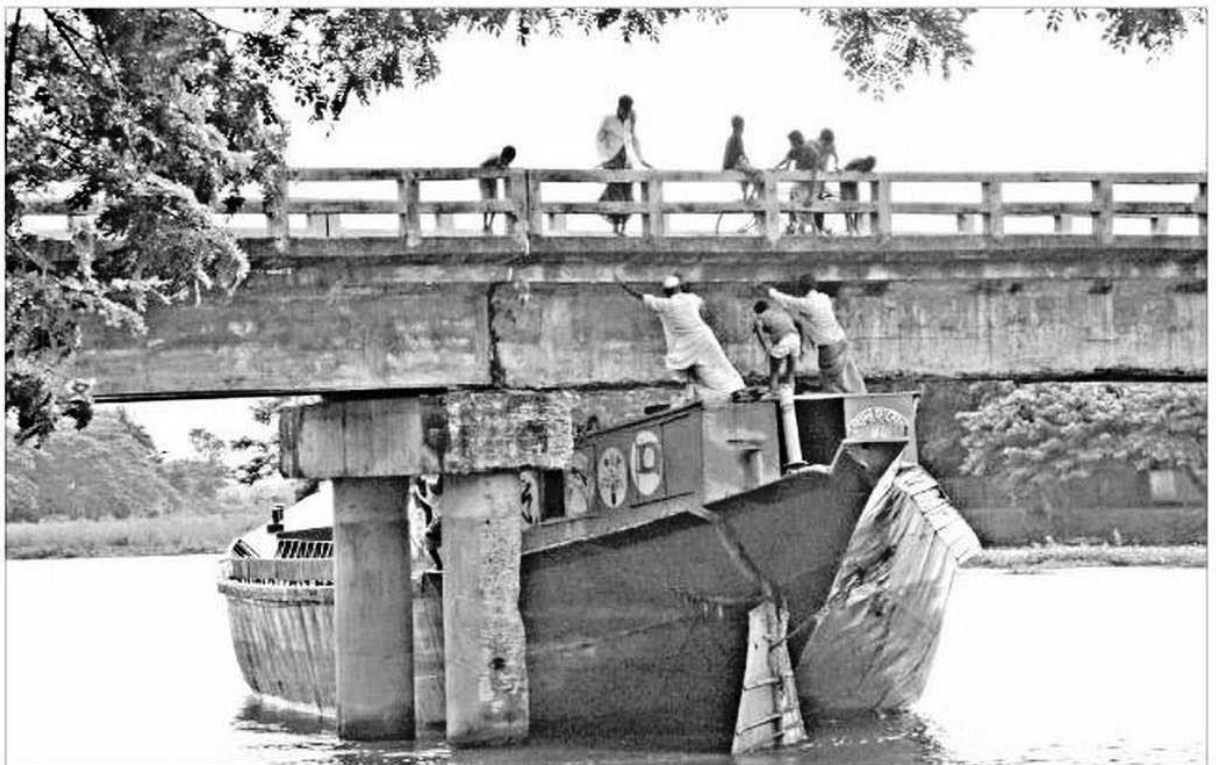

**Constraint of Multimodal System : Conflicting Roadways and Waterways**



Most of the level crossings create serious traffic jam.

### Constraint of Multimodal System : Conflicting Roadways and Railways

## CE 353 Transportation Engineering II: Railways



### Mass Rapid Transit (MRT) - Grade Separated and Segregated Heavy Rail System

#### Forms of MRT

- o Subway Metro (Traditional - under ground; most expensive to construct & run)
- o At-grade Metro (Present Trend - on ground; least expensive)
- o Elevated Metro (Present Trend - above ground or elevated)

#### Main advantages/hallmarks of MRT

- Most reliable mode of transport
- Huge ridership potential (40,000-60,000 passenger/phpd)
- It is very effective or strong congestion relieving tool
- Has enormous potential to reduce over crowding at at-grade level
- Most importantly it is a **demand responsive sustainable mode**



Prof. Dr. Md. Shamsul Hoque

## CE 353 Transportation Engineering II: Railways



### Facts of MRT Sustainability

- Tube/Underground Metro was 1st introduced in London in 1863 (Public Rail started in 1825)
- At present, 174 cities have metro system (including driverless system)
- Another 65 cities are going to have metro soon

In consideration of ever growing congestion level and energy crisis -

**It is evident that the 21st century would be the century of different forms of Public Transport or Mass Transit Systems.**



Source: Wikipedia, the free encyclopedia

Prof. Dr. Md. Shamsul Hoque

## CE 353 Transportation Engineering II: Railways

### World's Largest Subway Systems (by Ridership)

City	Date system completed	Number of Riders (year)	Length (km)
Moscow	1935	3.2 bil (1997)	340
Tokyo	1927	2.6 bil (1997/98)	281+
Seoul	1974	1.4 bil (1993)	278+
Mexico City	1969	1.4 bil (1996)	202
New York City	1904	1.3 bil (2001)	371
Paris	1900	1.2 bil (1998)	211
Osaka	1933	957 mil (1997)	114
London	1863	866 mil (1999)	415
Hong Kong	1979	790 mil (1999)	82
St. Petersburg	1955	721 mil (1996)	110

Sources: Jane's Urban Transport Systems, 2002–2003 edition, and individual subway websites

Prof. Dr. Md. Shamsul Hoque

## CE 353 Transportation Engineering II: Railways

### The most-used metro systems in terms of passenger rides per year:

1.  Tokyo Subway	3.174 billion (2008)	16.  Madrid Metro	690 million (2007)
2.  Moscow Metro	2.573 billion (2008)	17.  Kiev Metro	642 million (2007)
3.  Seoul Subway (SMRT)	2.047 billion (2008)	18.  Guangzhou Metro	601 million (2008)
4.  New York City Subway	1.624 billion (2008)	19.  Prague Metro	597 million (2008)
5.  Mexico City Metro	1.460 billion (2008)	20.  Singapore MRT	571 million (2008)
6.  Paris Métro	1.388 billion (2007)	21.  Caracas Metro	510 million (2008)
7.  Hong Kong MTR	1.309 billion (2008)	22.  Vienna U-Bahn	498 million (2008)
8.  Beijing Subway	1.200 billion (2008)	23.  Toronto Transit Commission	459 million (2007)
9.  London Underground	1.197 billion (2007)	24.  Taipei Metro	450 million (2008)
10.  Shanghai Metro	1.122 billion (2008)	25.  Berlin U-Bahn	446 million (2008)
11.  São Paulo Metro	945.8 million (2008)	26.  Barcelona Metro	422 million (2008)
12.  Osaka Municipal Subway	877.8 million (2007)	27.  Montreal Metro	382 million (2008)
13.  Saint Petersburg Metro	829.8 million (2007)	28.  Munich U-Bahn	349 million (2008)
14.  Santiago Metro	803.0 million (2008)	29.  Rome Metro	331 million (2008)
15.  Cairo Metro	700.0 million (2002)	30.  Stockholms tunnelbana	329 million (2005)
		31.  Milan Metro	318 million (2006)
		32.  Budapest Metro	297 million (2008)
		33.  Athens Metro	278 million (2006)
		34.  Kharkov Metro	278 million (2007)

Source: Wikipedia, the free encyclopedia

Prof. Dr. Md. Shamsul Hoque



### **Sustainable System:**

Which give solution for present problem/travel demand as well as has the potential to respond to the ever growing future demand without requiring heavy investment.



**MRT is sustainable as it is demand responsive.**



Prof. Dr. Md. Shamsul Hoque



**MRT can respond to the demand by increasing riding capacity in the following ways:**

- Increasing frequency
- Increasing compartment number
- Increasing speed
  
- Improving compartment capacity by
  - o Eliminating seating service
  - o Packing passengers
  
- Making more space efficient by introducing
  - o Double decker Trains
  - o Double decker Tracks



Prof. Dr. Md. Shamsul Hoque



PASSENGER PACKING / PUSHING



*Prof. Dr. Md. Shamsul Hoque*

## Transportation Mode

<b>Model</b>	<b>Capacity</b>	<b>Number of Bogeys</b>	<b>Headway (Min)</b>	<b>Capacity (pass/hr/direction)</b>
<b>Taxi</b>	<b>7</b>	<b>-</b>	<b>-</b>	<b>-</b>
<b>Van</b>	<b>11</b>	<b>-</b>	<b>-</b>	<b>-</b>
<b>Bus</b>	<b>75-80</b>	<b>-</b>	<b>0.67</b>	<b>5000-9000</b>
<b>Streetcar</b>	<b>99-139</b>	<b>3</b>	<b>2</b>	<b>8000-15000</b>
<b>Light Rail Transit</b>	<b>74-200</b>	<b>3</b>	<b>1.5</b>	<b>12000-20000</b>
<b>Rapid Rail Transit</b>	<b>210-360</b>	<b>3-10</b>	<b>2</b>	<b>40000-62000</b>

### Modal Share of Freight Transportation by Different Alternatives

Year	Freight				
	Ton-km (Billion)	Road %	Rail %	Water %	Total %
1974-75	2.6	35.0	28.0	37.0	100
1984-85	4.5	47.0	17.0	36.0	100
1994-95	7.2	57.0	13.0	30.0	100
1996-97	10.0	63.0	7.0	30.0	100
2004-05 (Projected)	11.7	65.0	10.0	25.0	100

Source: Baglapedia 2004 and BBS 2001.

## Development Allocation of Different Modes of Transportation

Year	Road %	Rail %	Water %	Total %
1999-2000	73	16	5	95
2000-2001	72	22	1	95
2001-2002	78	18	2	97
2002-2003	80	19	1	99
2003-2004	76	22	1	100

Source: BIWTA 2003

### Methods of Infrastructure Development

- Public
- Private
- Build, Own, Operate and Transfer (BOOT)
- Public Private Partnership (PPP)
- Supply Operate and Transfer (SOT)

# Road–Traffic System

## Introduction

The Road-Traffic system is a complex interaction among four components -

- Road
- Vehicle
- Road user
- Roadway Environment



## ROAD

It comprises of follows building blocks:

- o For moving Traffic \*
  - o At-grade elements
    - Links
    - Intersections
    - Shoulder / Footpath
    - Embankment
  - o Grade separated elements
    - Overpass
    - Underpass
    - Road bridges/culverts
    - Flyover/Viaduct
    - Interchange
    - Tunnel
    - Foot bridge
- o For stationary Traffic
  - Bus lay-by/pull-outs
  - Parking areas
  - Loading/unloading areas
  - Terminals/Stations
- o Roadway Furniture
  - Median
  - Divider
  - Channel
  - Island
  - Traffic control devices

*Note: \* Traffic - Vehicle and Pedestrian*

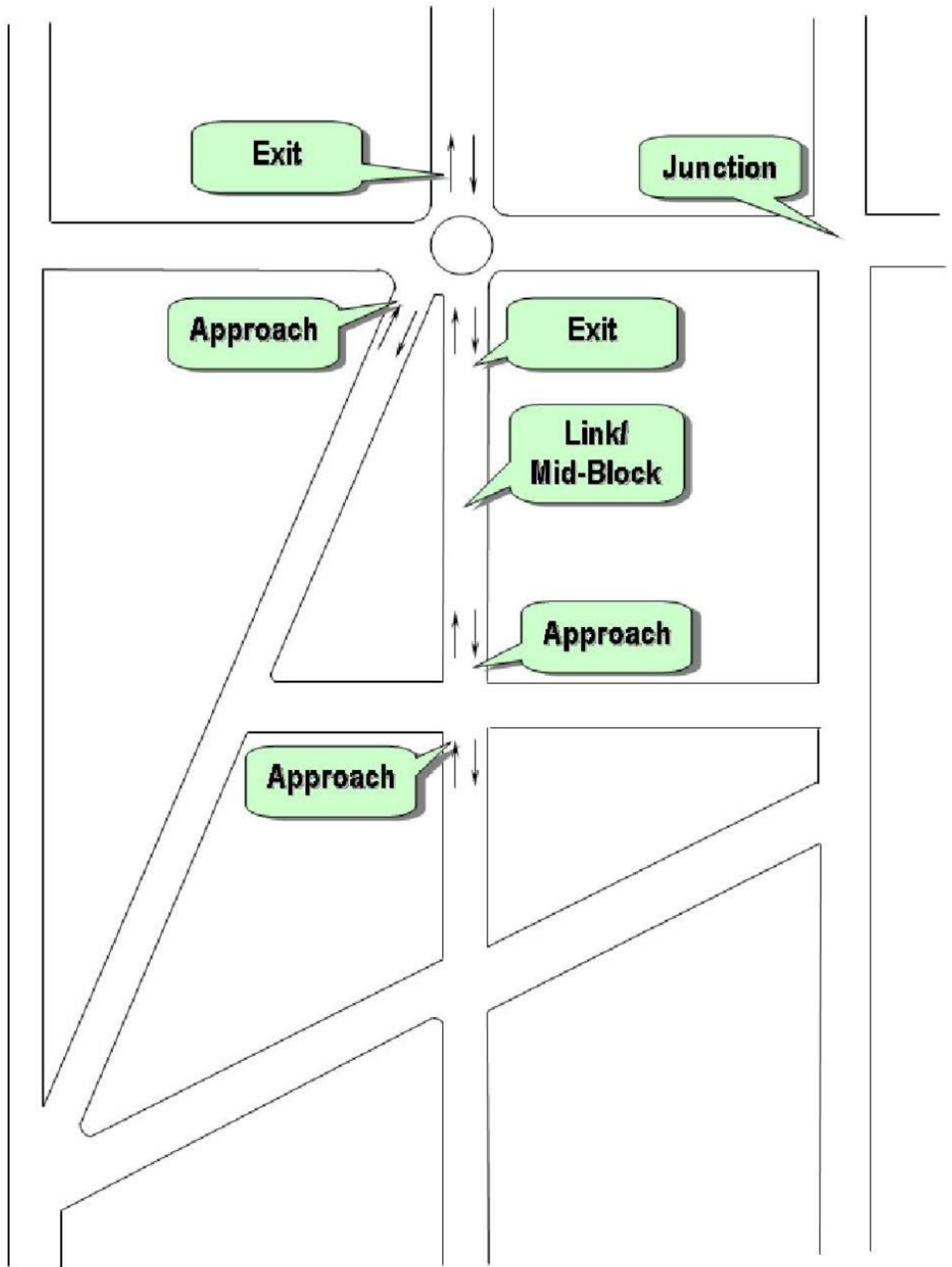

## ROAD NETWORK

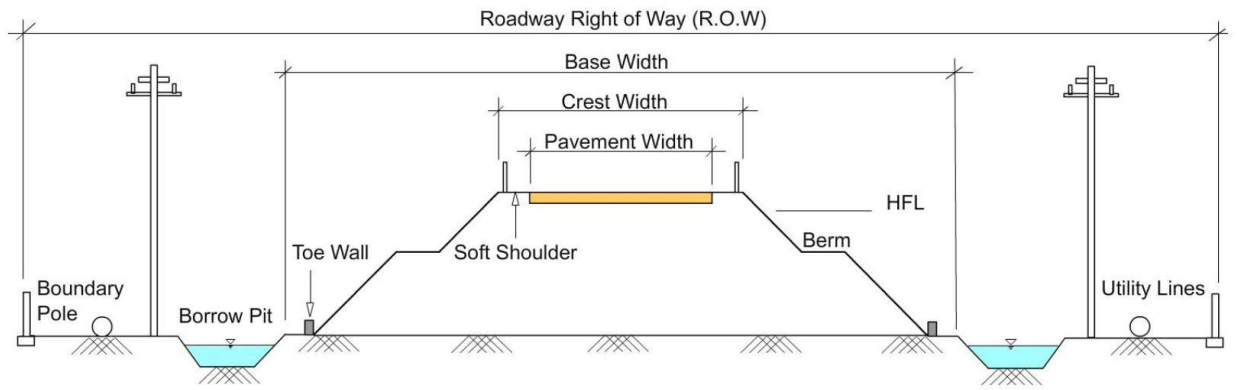

**Typical Cross-Section of Highway Embankment**

Capacity Augmentation by Raising the Ground Level Road

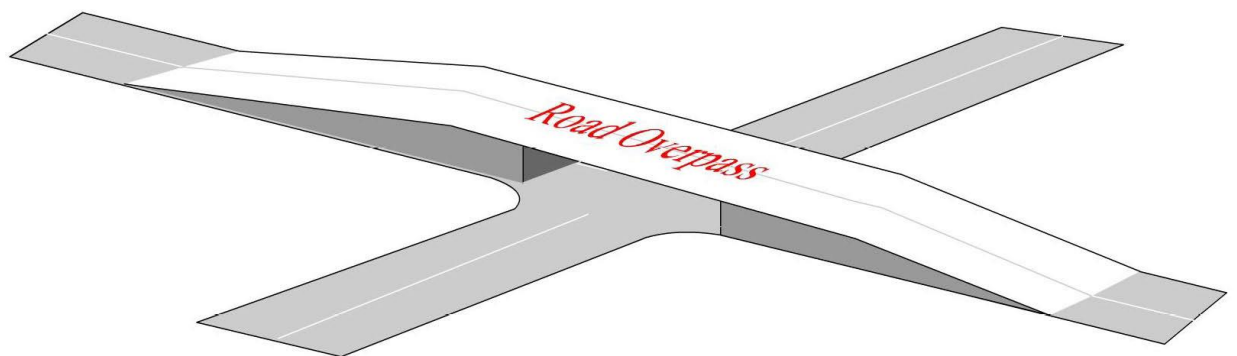

Culvert (Flat Deck)



Bridge (Curved Deck)



Causeway



Tunnel

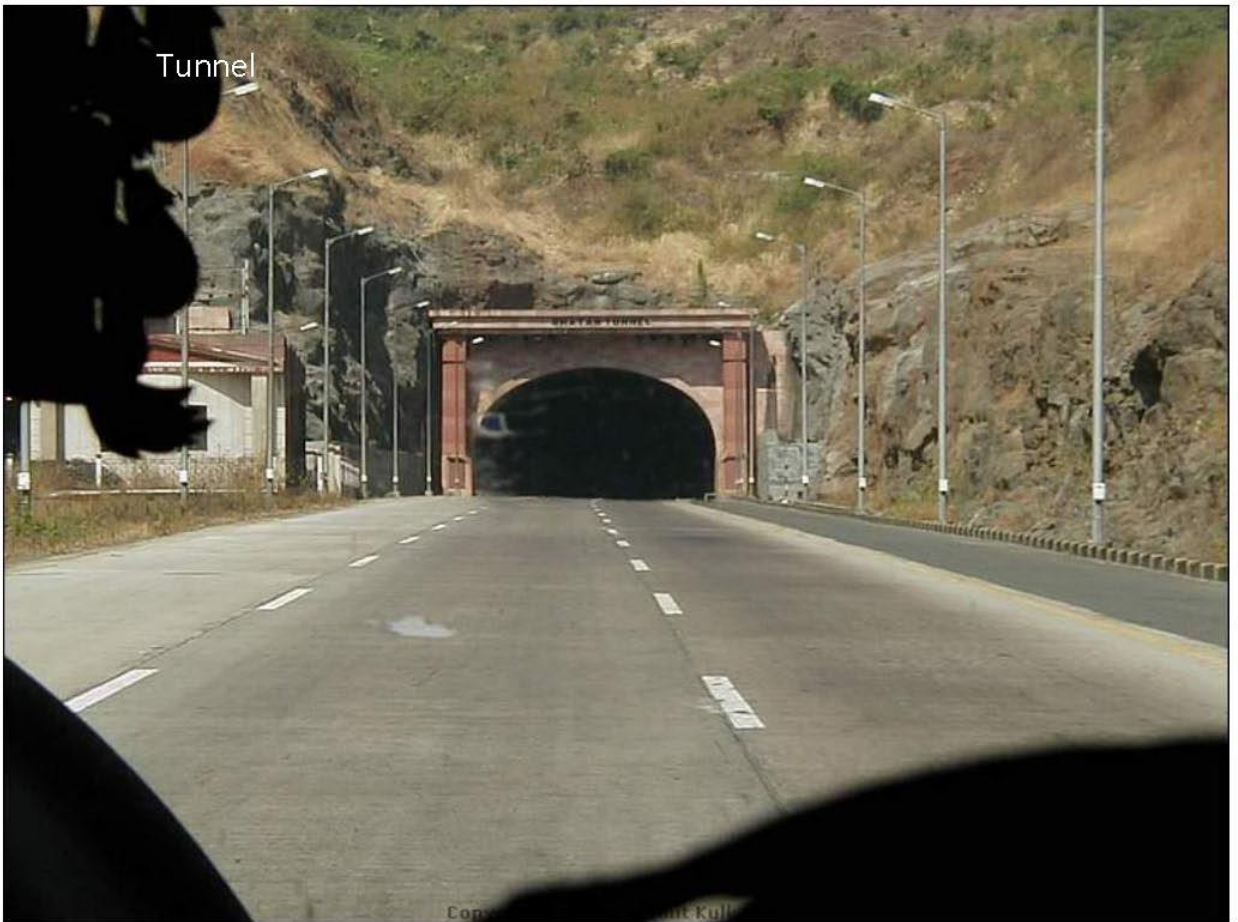

Foot Over Bridge  
(Overpass)



Foot Under Bridge  
(Underpass)

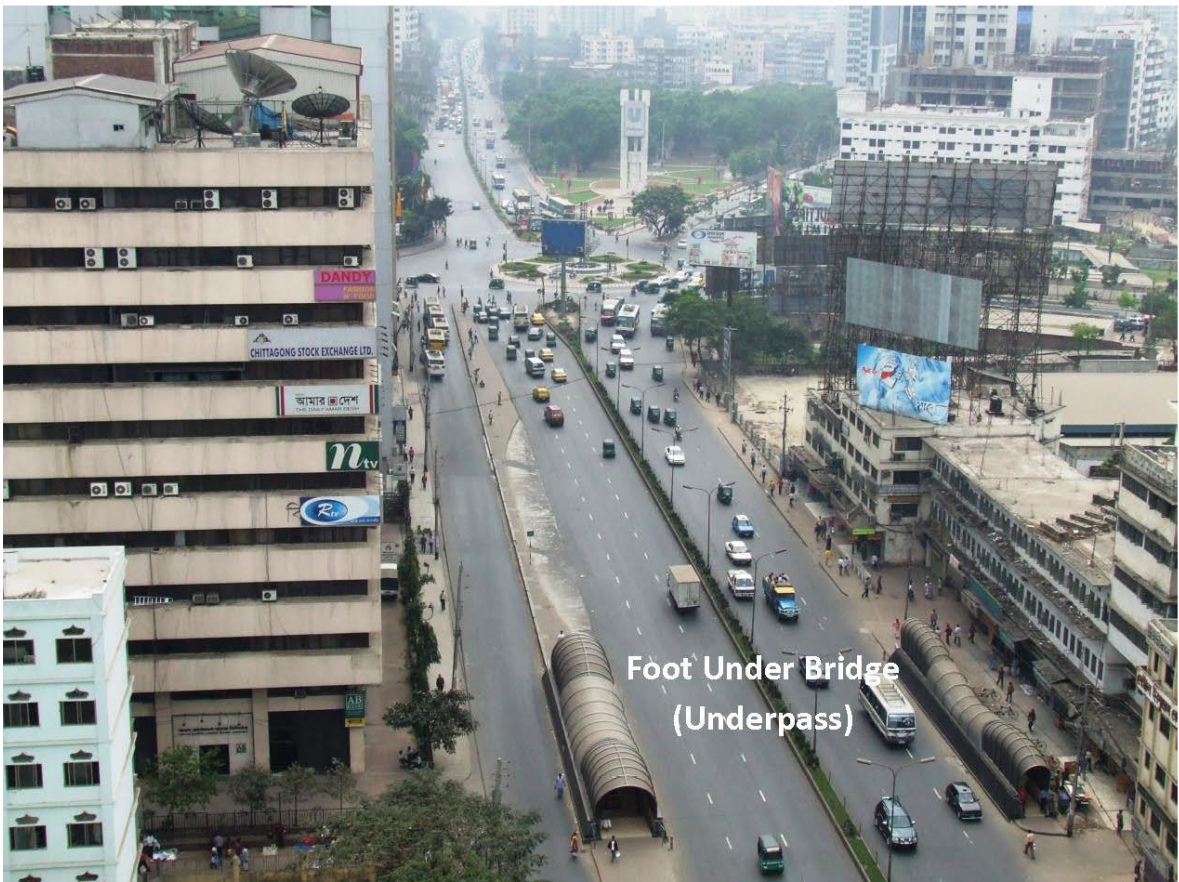

Road Divider



Road Median







# CE 6502 Geometric Design of Highways

## Roadway Classification

- A. Geographical area or location-wise
- B. Terrain-wise
- C. Function-wise
- D. Standard-wise
- F. Usage-wise
- G. Operation-wise
- H. Surface type-wise
- I. Investment-wise



# CE 6502 Geometric Design of Highways

## Roadway Classification

- A. Geographical area or location-wise
  - Rural Road – open area
  - Urban Road – built up area
  - Sub-Urban Road – semi-built up area
- B. Function-wise
  - RHD
    - National Highways (N) – Capital/Port
    - Regional Highways (R) – Divisional rd
    - Zila Road (Feeder Rd) – District rd, 64
  - LGED
    - Upazila/Thana Road (Feeder Rd, 476)
    - Union/Village Road – Growth center
  - Terrain-wise
    - Plain / Level
    - Rolling
    - Hilly / Mountainous
  - Urban Road
    - Arterial Road – Bypass rd
    - Primary Road – Mixed urban rd
    - Secondary Road – Pure urban rd
    - Connector/link Road – Distributor
    - Local Road – Access
    - Alley/Lane/Bylane – for NMT



**Rural Road in Open Area**



**Urban Road in Built up Area**



Suburban Road in Semi-Built up Area



Road on Plain/Level Terrain

2005 12 24



**Road on Rolling Terrain**



**Road in Hilly / Mountainous Terrain**



**Arterial Road / Freeway / Expressway**



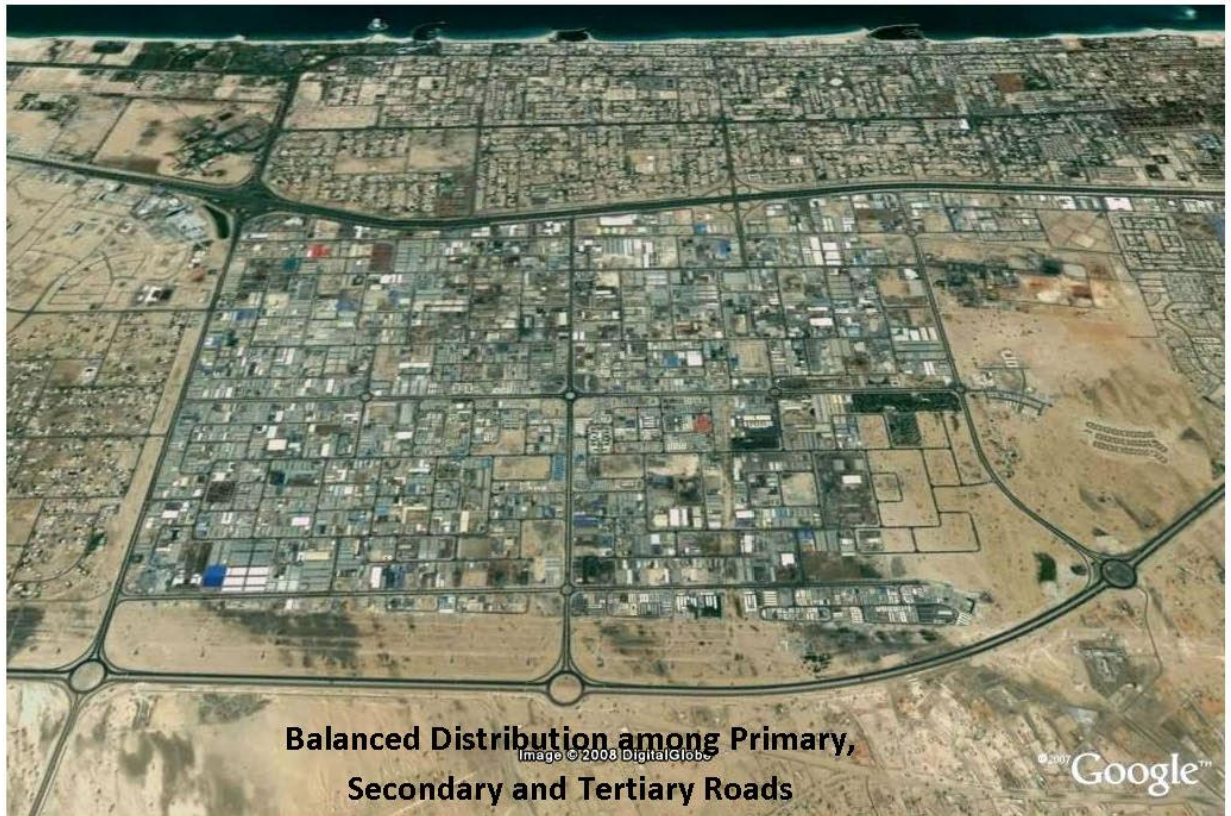

Balanced Distribution among Primary,  
Secondary and Tertiary Roads



Cul-de-Sac in Residential Area to Discourage Trough Traffic

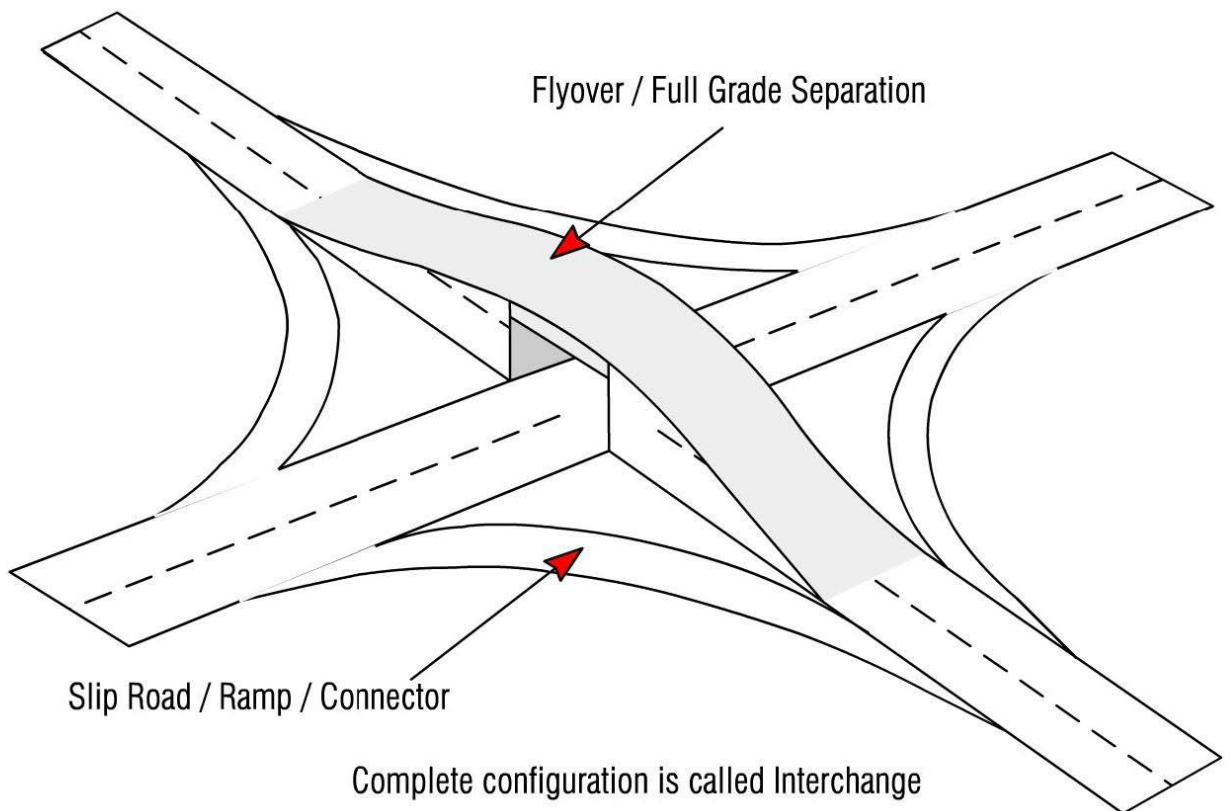
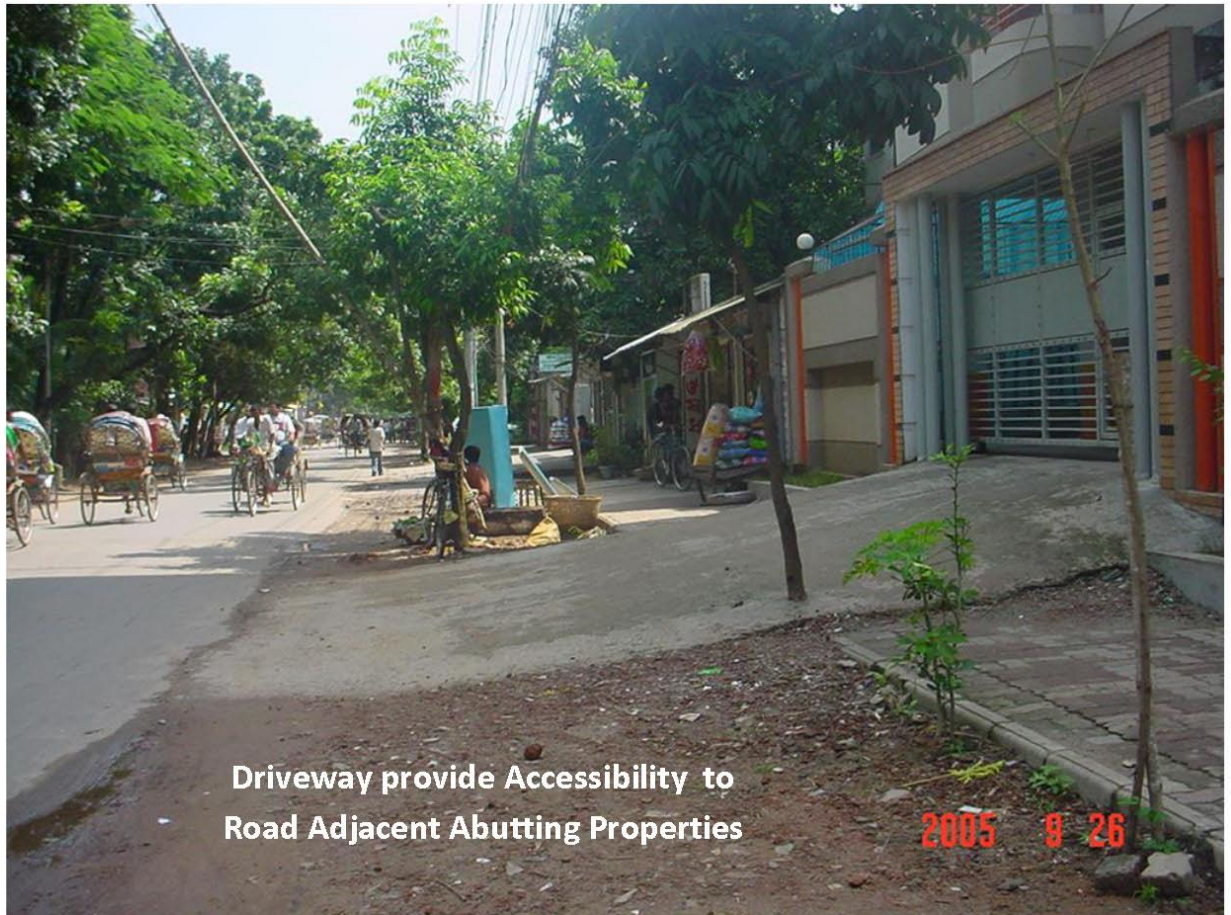

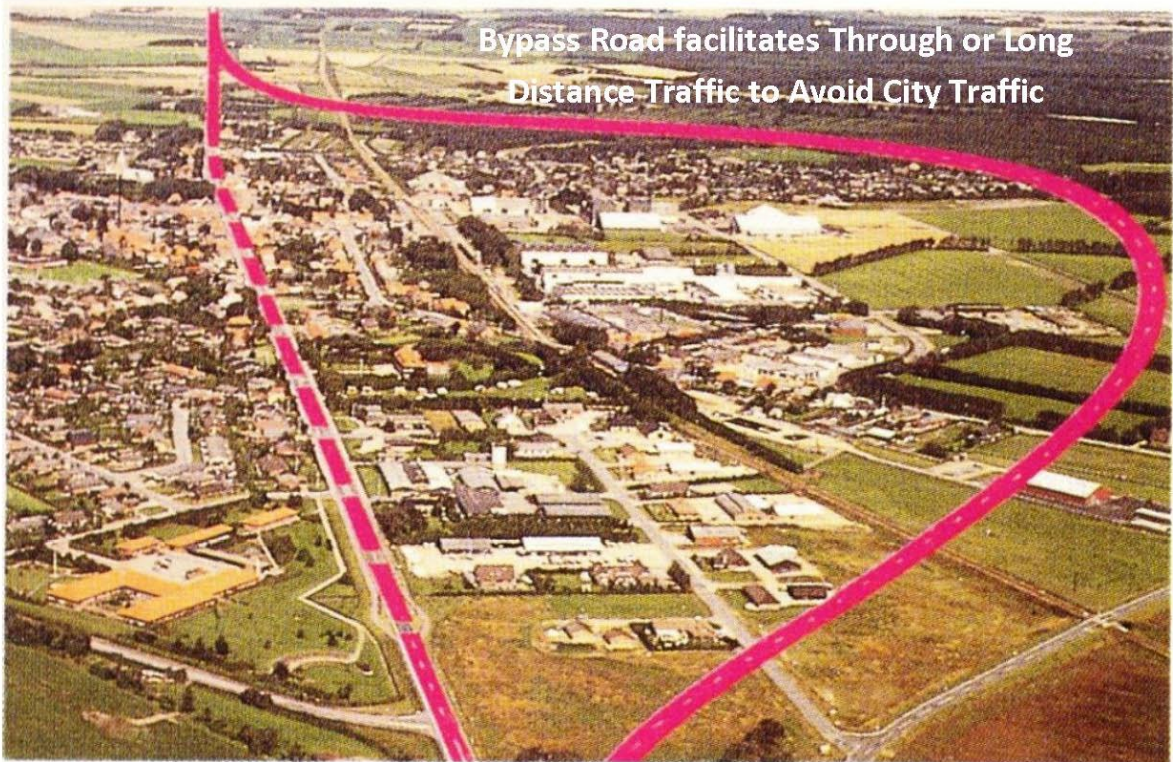

## CE 6502 Geometric Design of Highways

### Roadway Classification

#### E. Operation-wise

- Single Carriageway/Undivided Road
- Dual Carriageway/Divided Road
- Two way
- One-way (bi-nary)
- Tri-nary with transit corridor
- Reverse/Tidal Flow with HOV or BRT
- Lane/non-lane

#### F. Surface type-wise

- Earthen road (connecting isle/tak)
- All weathered road
- Block pavement - Speed calming device
- Flexible pavement
- Rigid pavement - Safer/Fit & Forget type

#### G. Investment-wise

- Public Road - Free
- Private: Build, Operate and Transfer (BOT/BOOT) – Tolloed

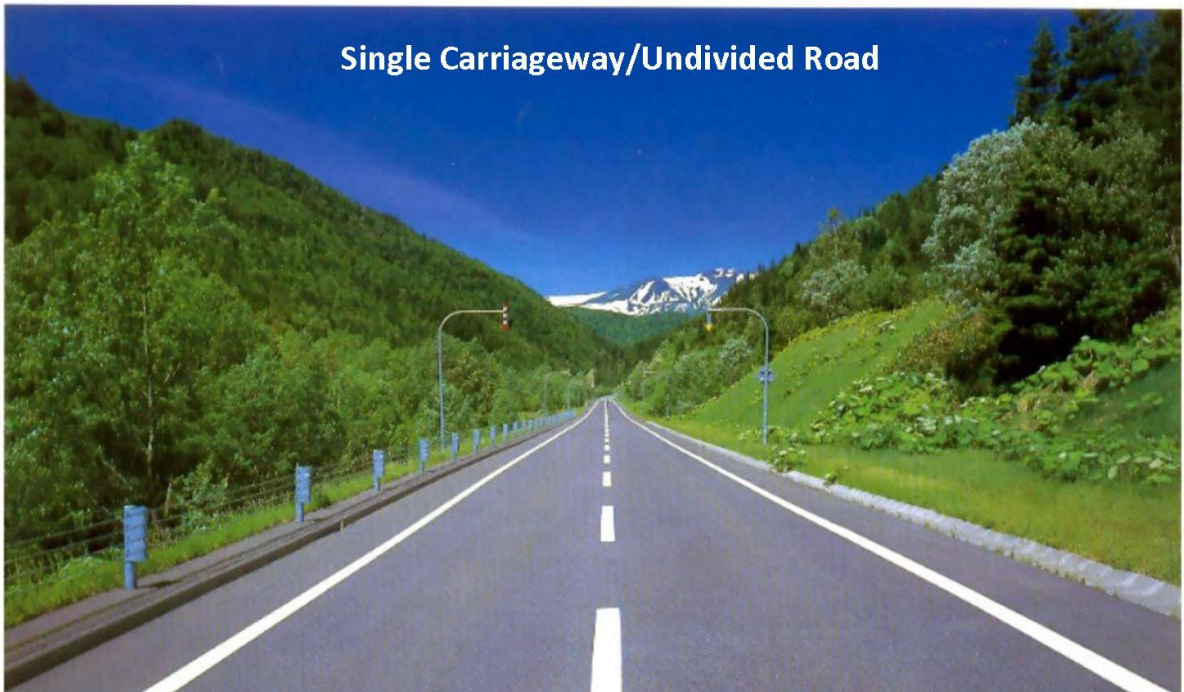

Dual Carriageway / Divided Road

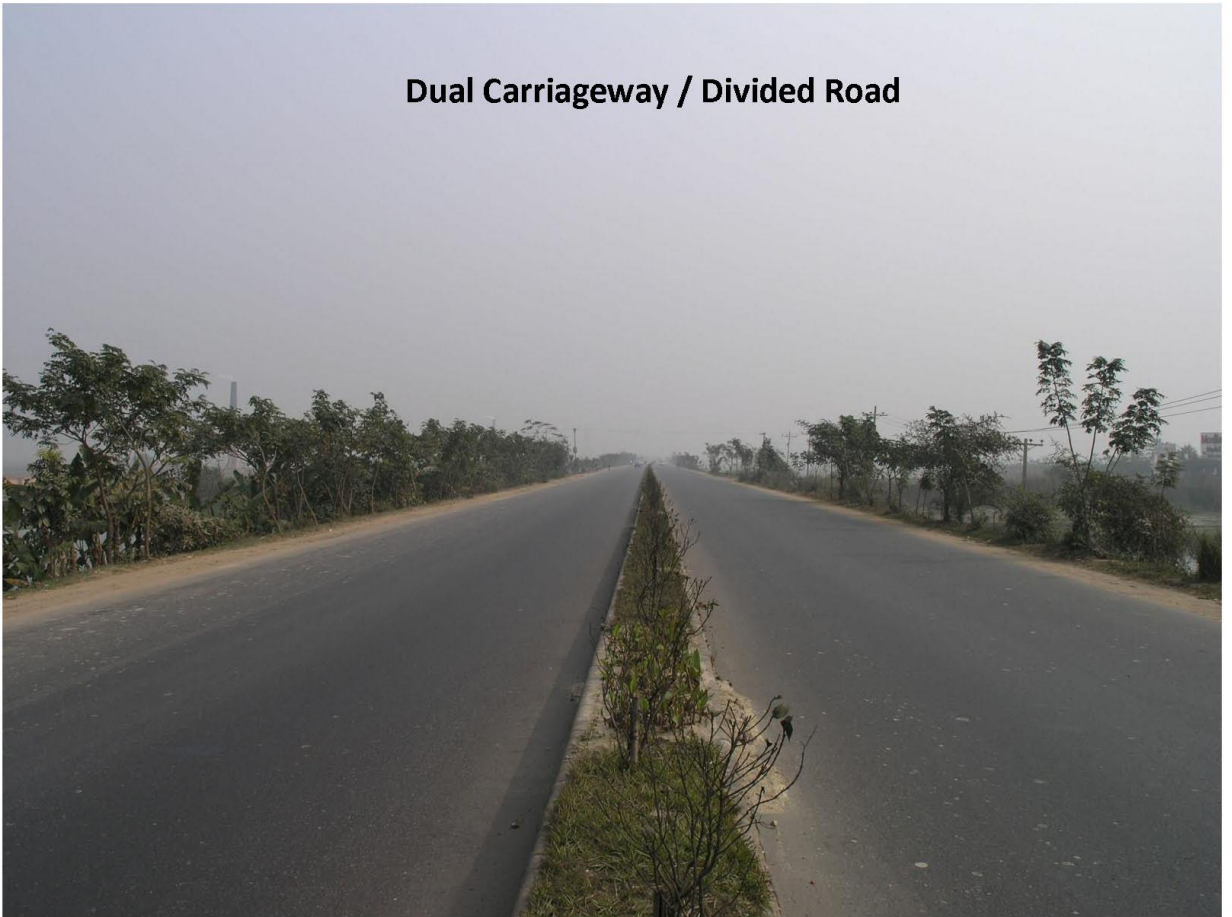

Oneway Traffic Operation



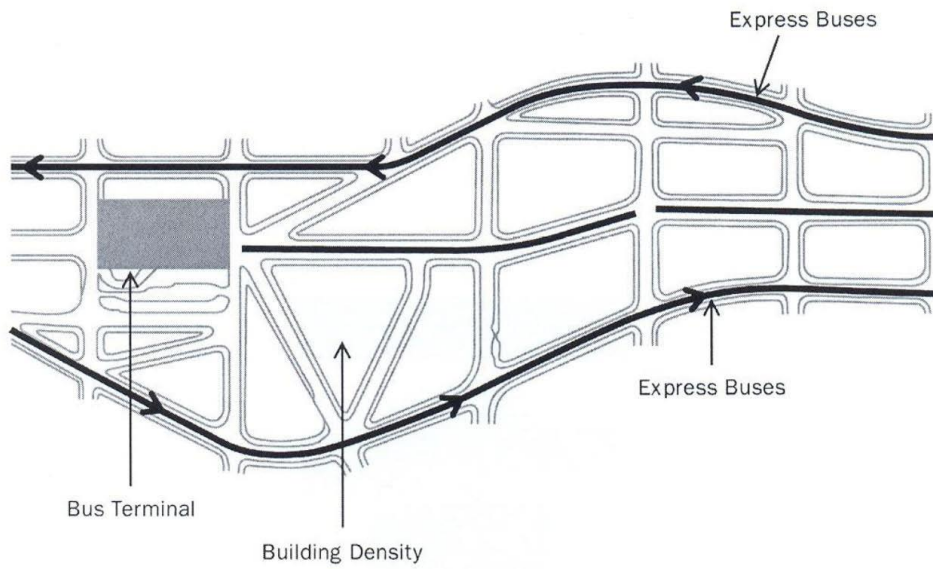
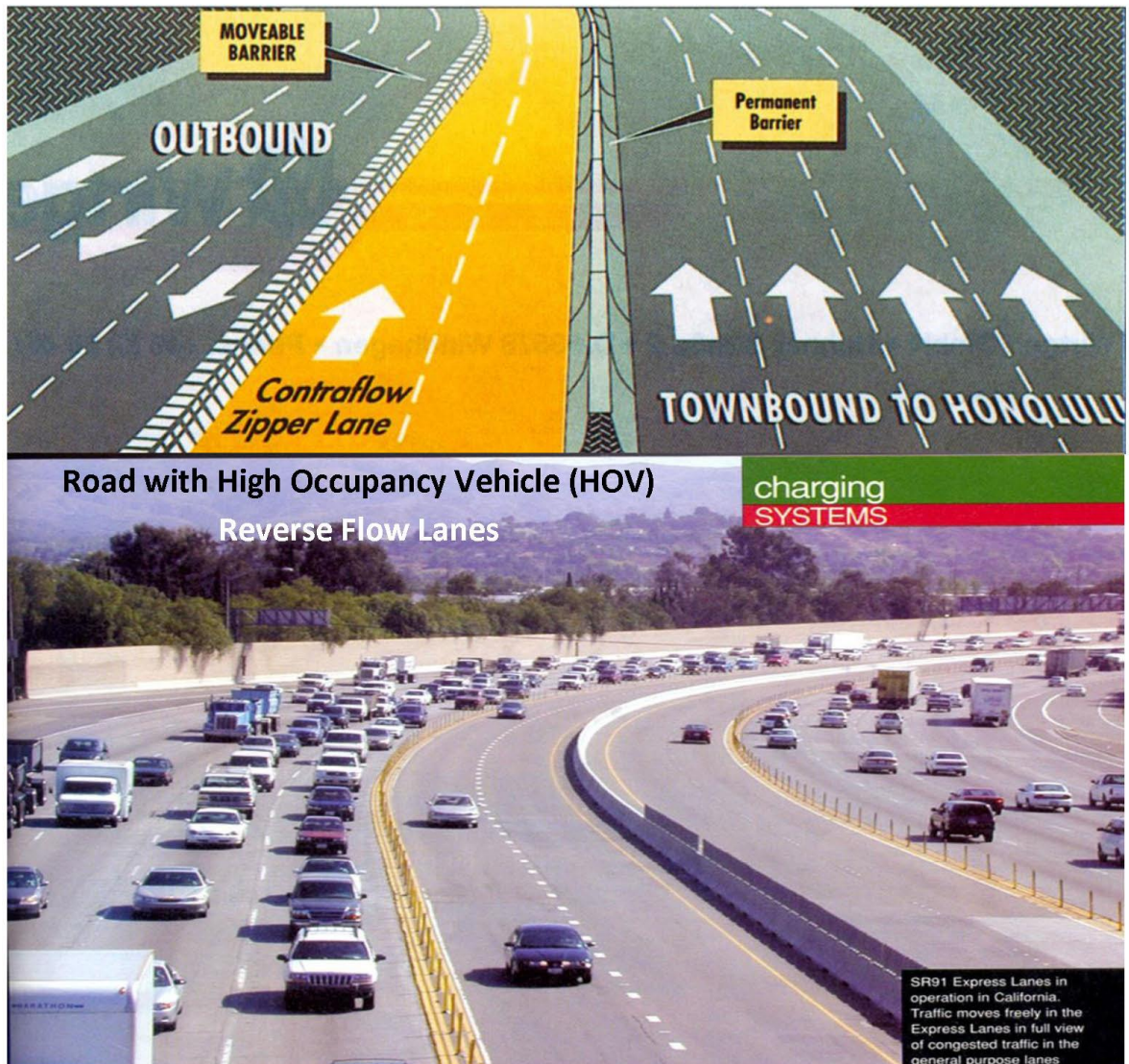

Figure 1: Trinary Road Concept





**Lane Based Homogeneous  
Motorized Traffic Operation**



**Non-Lane Based Heterogeneous  
Mixed Traffic Operation**



**Earthen Road**



**Brick Paved Road**

**Bituminous / Flexible Pavement Road**



**Concrete / Rigid Pavement Road**



## Intersection Classification

### Basic form-wise

- At-grade
- Tee
- Wye
- Cross
- Skewed
- Staggered
- Roundabout

### Operation-wise

- Uncontrolled
- Controlled
  - Priority Controlled
  - Signalized

### Grade separated interchange

- Trumpet
- Diamond
- Clover-leaf
- Roundabout/rotary



## Intersection Classification

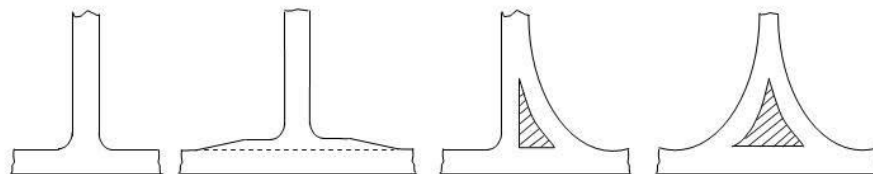

Unchannelized T

Flared T

Channelized T

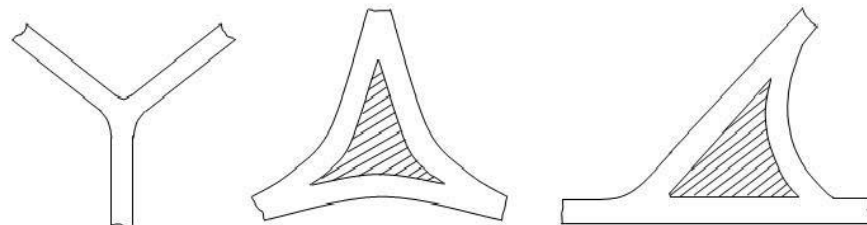

Unchannelized Y

Channelized Y

### 3-LEG INTERSECTIONS



## Intersection Classification

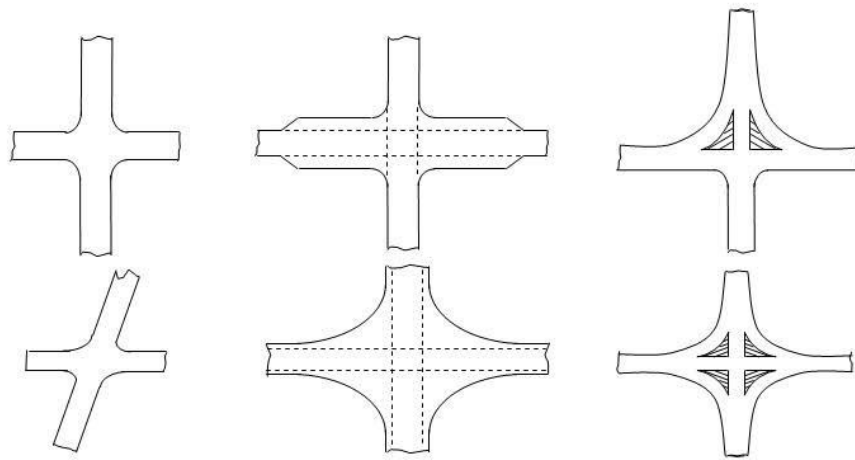

Unchannelized Cross

Flared Cross

Channelized Cross

### 4-LEG INTERSECTIONS

## Intersection Classification

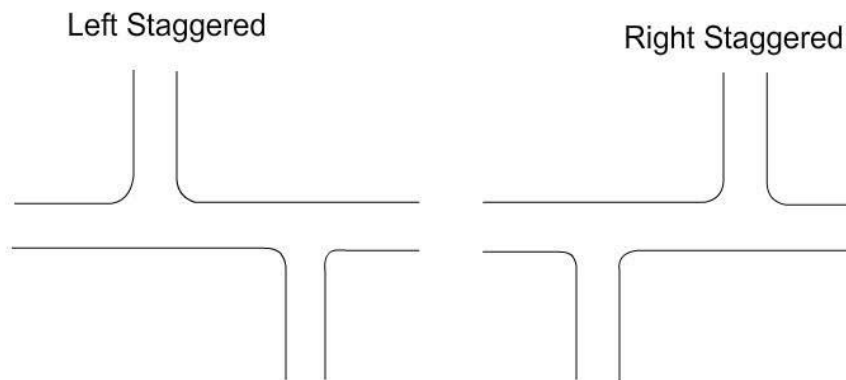

Left Staggered

Right Staggered

### STAGGERED INTERSECTION



**Staggered intersection**

## Intersection Classification

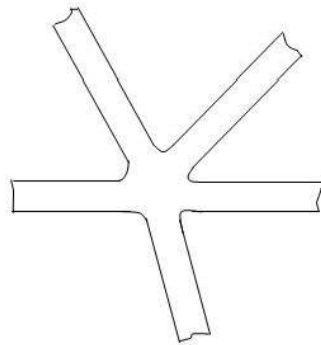

**Multileg**

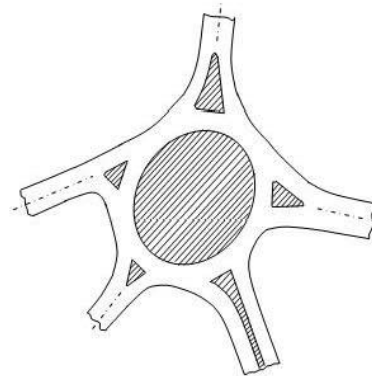

**Rotary/Roundabout**

### MULTI-LEG INTERSECTIONS



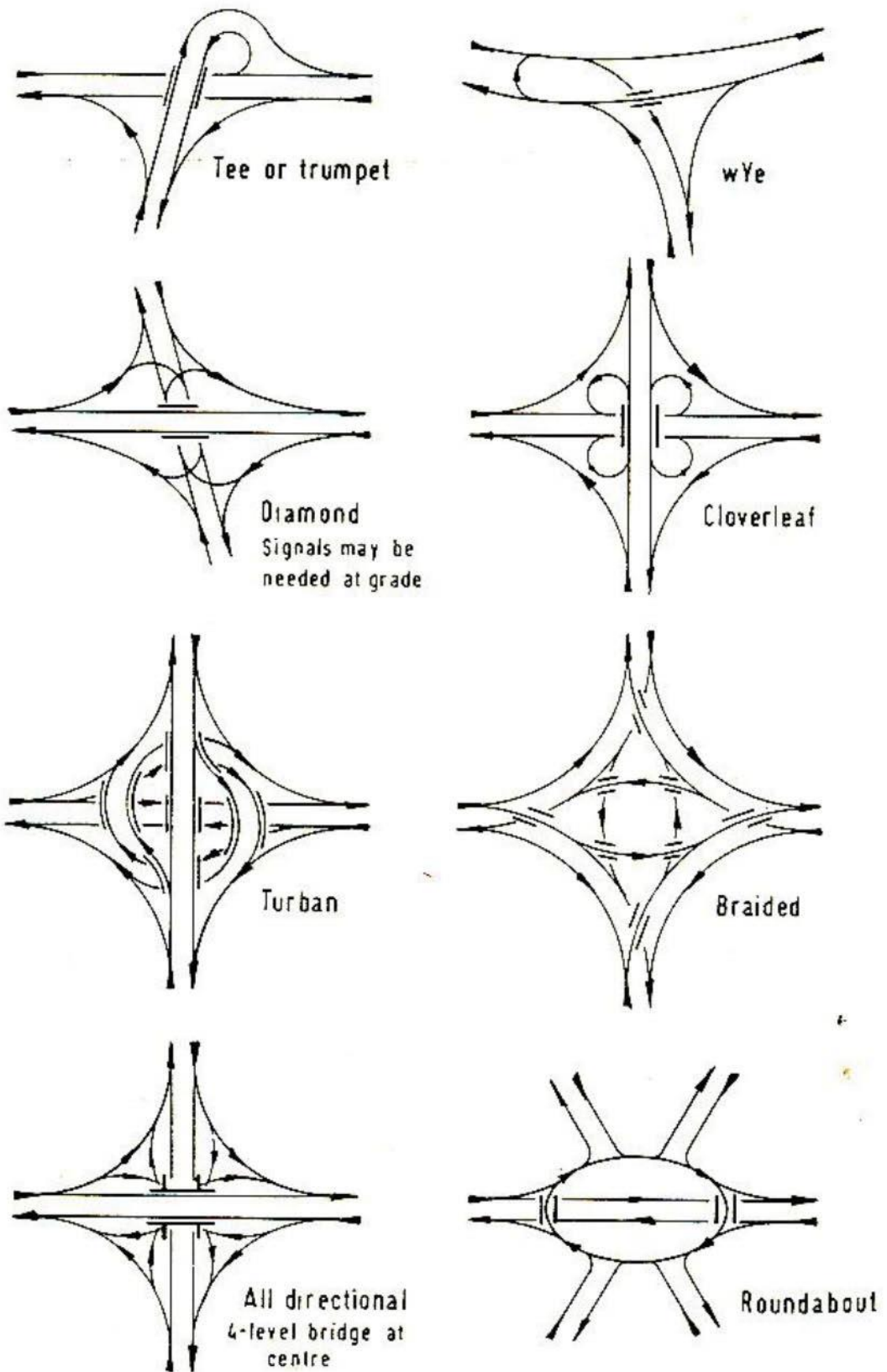
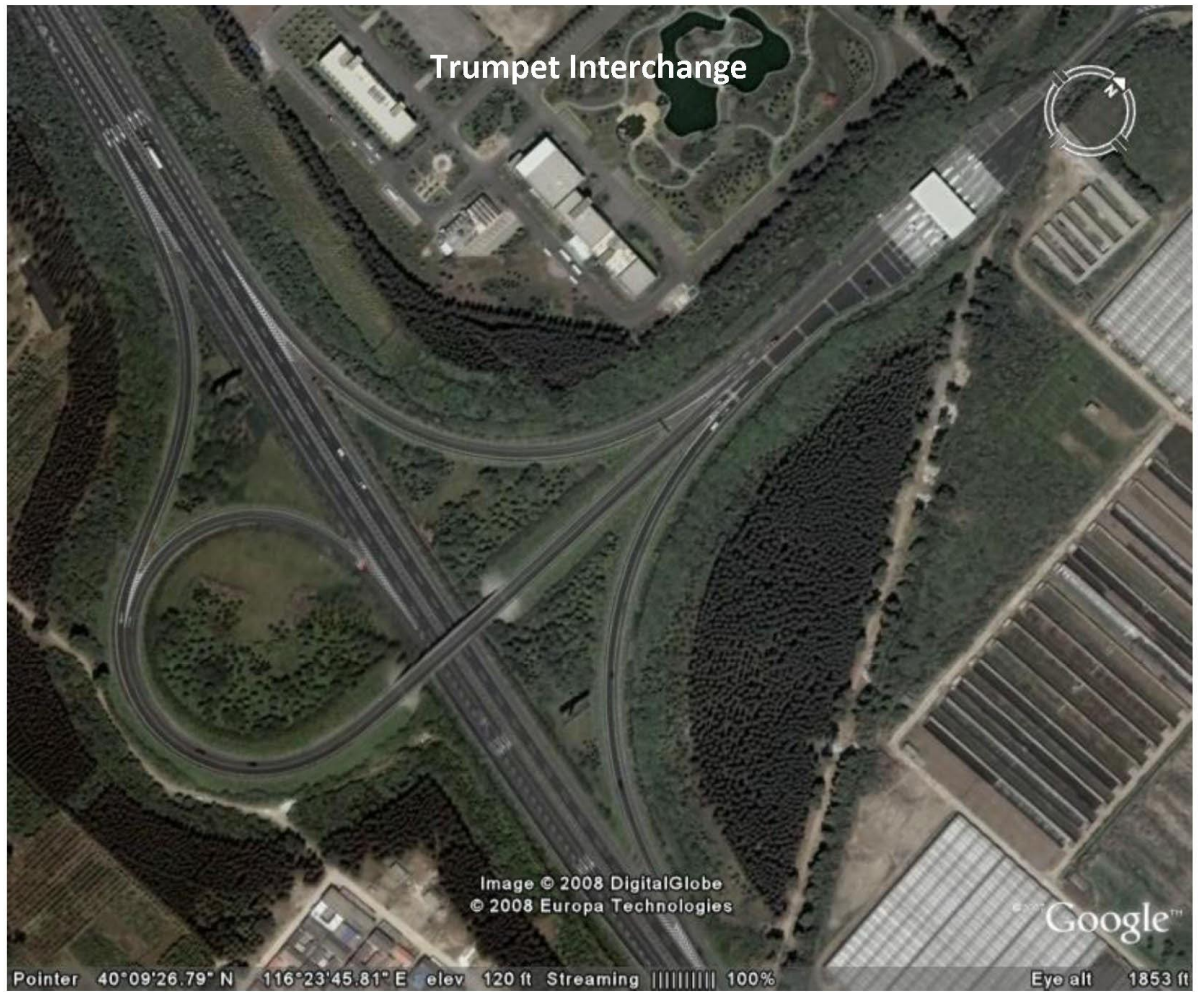
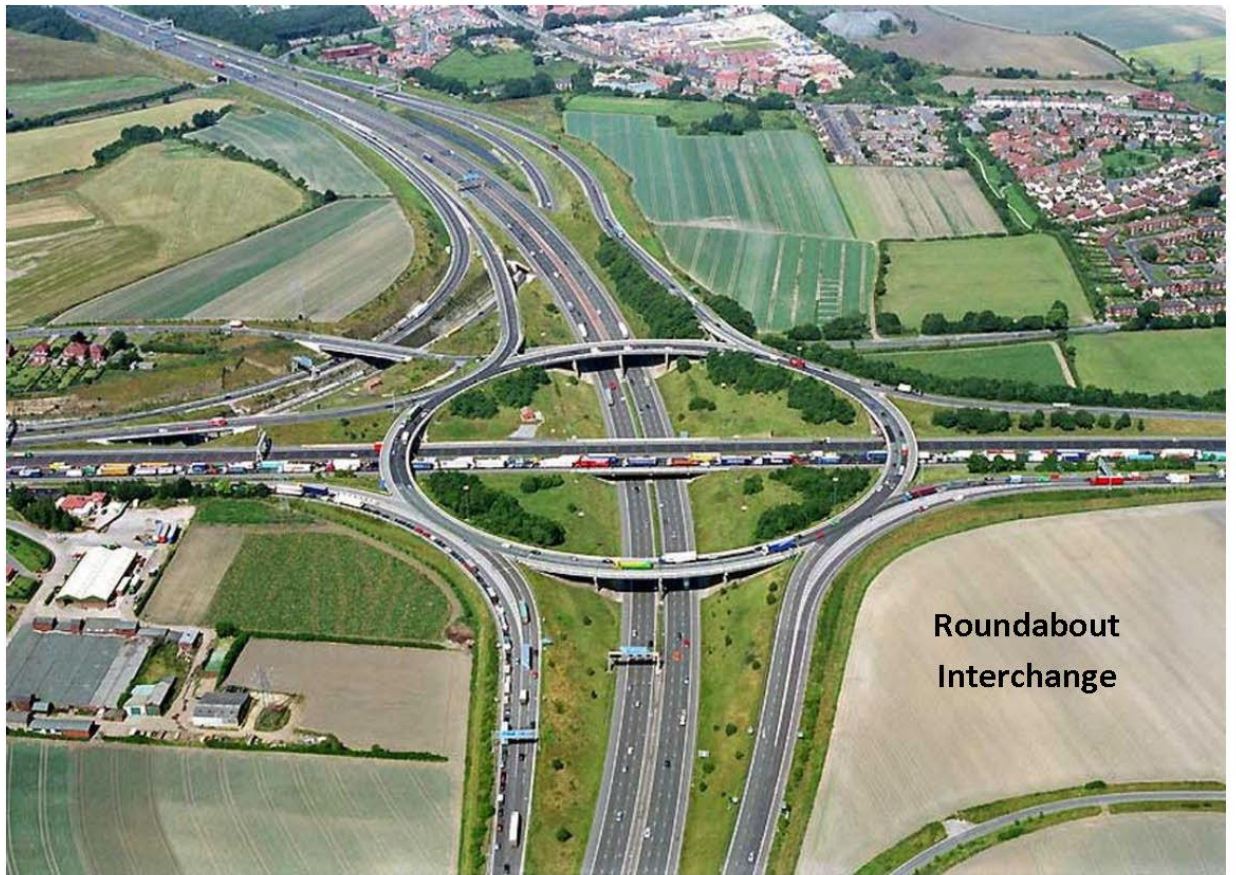

Fig. 6.26. Diagrammatic examples of some basic traffic movements at interchanges



Cloverleaf Interchange





**Roundabout  
Interchange**



**Uncontrolled Intersection**

Priority Type Intersection( Give way)



Priority Type Intersection (Mandatory Stop)



# Road–Traffic System

## Introduction

The Road-Traffic system is a complex interaction among four components -

- Road
- Vehicle
- Road user
- Roadway Environment



CE - 351

# Road–Traffic System

## VEHICLES

### Types of Vehicle

#### A. Propulsion force wise

- Motorized
  - Truck
    - Large
      - Single
      - Covered Van
      - Articulated
        - Trailer
        - Semi-trailer
    - Small
      - Mini
      - Pickup
  - Bus
    - Large
      - Single-deck
      - Double-deck
      - Articulated
    - Mini
    - Micro
    - Car/Jeep etc.
    - CNG/Tempoo
    - Human Hauler
    - Motorcycles
    - Other non-Standard Veh
- Non-motorized
  - Rickshaw
  - Rickshaw Van
  - Bicycle
  - Push cart
  - Animal driven cart



Prof. Dr. Md. Shamsul Hoque

## Semi Trailer Trucks



## TYPES OF TRUCKS

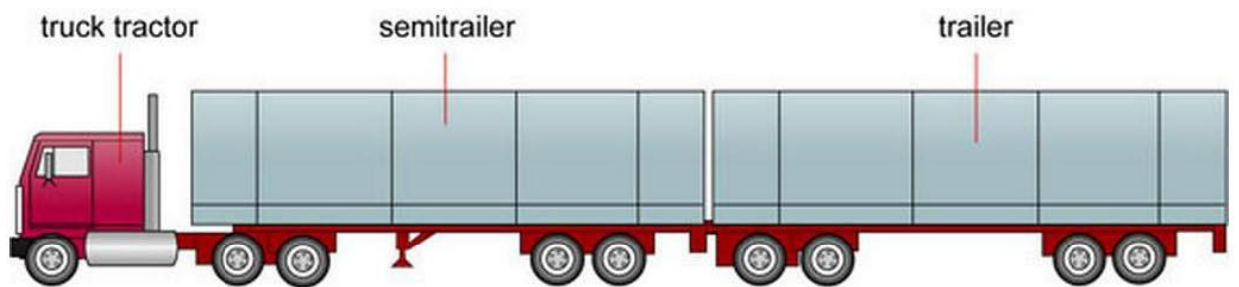

articulated vehicle

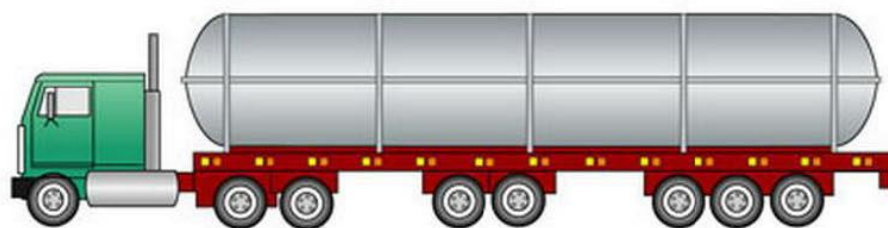

tank truck

[www.infovisual.info](http://www.infovisual.info)

Covered Van Truck



Articulated Bus



# Road–Traffic System

## VEHICLES

### Types of Vehicle ..... Contd..

#### B. Service/usage-wise

- Private
- Public
  - Mass transit – Bus, Tempo, Tram, Trolley Buses, Light rail transit (LRT) etc.: use shared carriageway
  - Rapid transit – Underground rail/Metro/Tube/Subway, elevated Sky train, Mono rail etc.: use segregated carriageway
  - Personalized transit
    - Para-transit - rickshaw, auto rickshaw
    - Taxi service
    - Rent-a-Car/hired car



Prof. Dr. Md. Shamsul Hoque

# Road–Traffic System

### Types of Vehicle ..... Contd..

#### C. Carrier-wise

- Passenger vehicles
- Freight vehicles

#### D. Fuel/energy type-wise

- Petrol/Diesel
- Compressed Natural Gas
- Electricity
- Solar
- Fuel cell
- Hybrid

#### E. Driving force wise

- Two-wheel (2WD)
- Four-wheel drive (4WD)



Prof. Dr. Md. Shamsul Hoque

## Different Types of Vehicular Maneuvers

### At Intersection

- Crossing
- Merging
- Diverging
- Turning
- Weaving

### At Mid block

- Lane changing
- Overtaking

### Miscellaneous

- Reversing

## Different Types of Vehicular Maneuvers

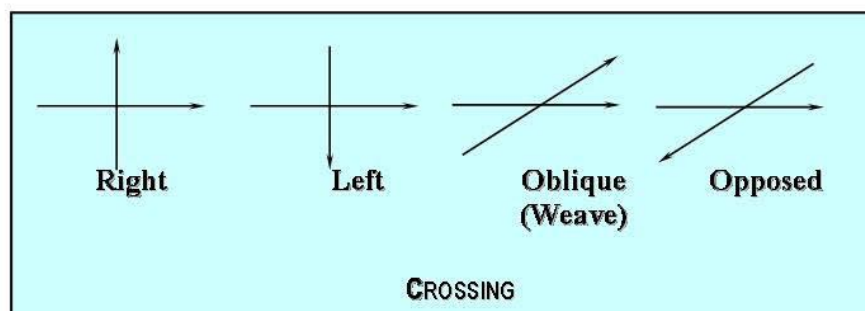

## Different Types of Vehicular Maneuvers

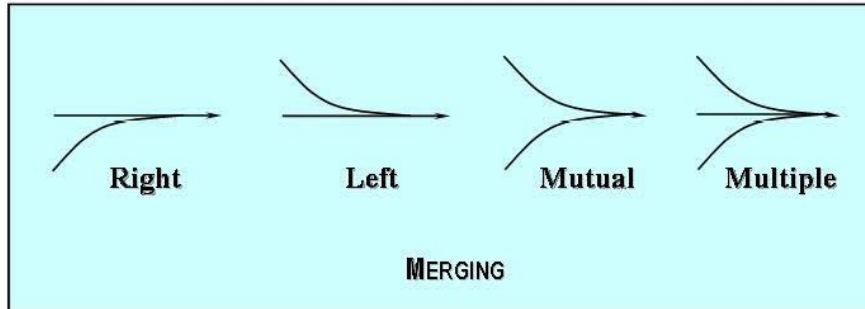

## Different Types of Vehicular Maneuvers

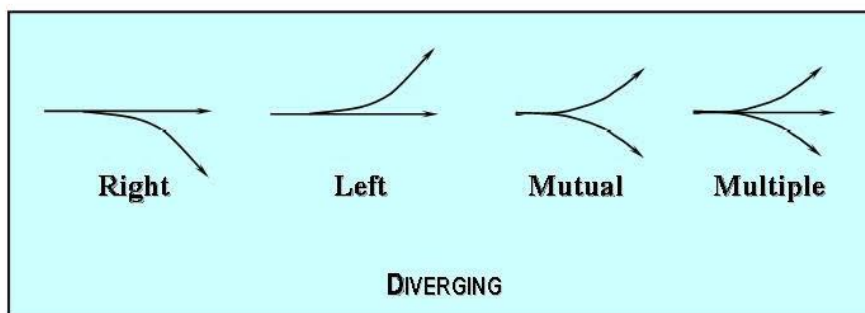



**Right Angle Crossing**



**Left Merging**



### See Weaving Movement

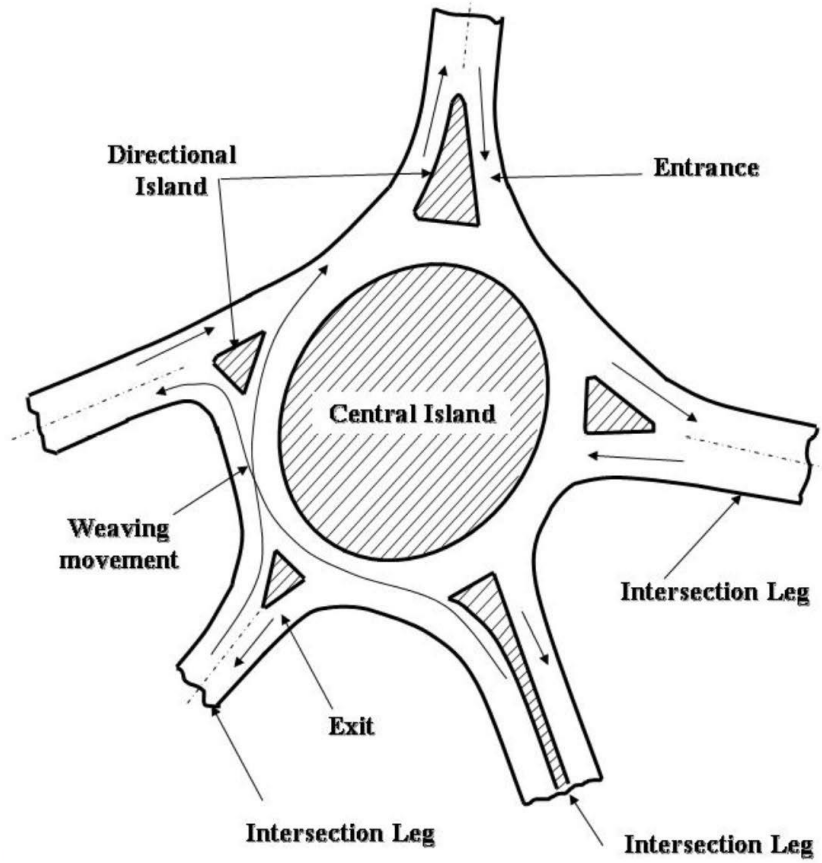

### Overtaking in 2-lane Road : Two Successive Lane Changing Maneuvers



# Road-Traffic System



## Road users

- Drivers
- Passengers
- Riders & Pillion
- Pedestrians



## Waiting Passenger

Prof. Dr. Md. Shamsul Hoque



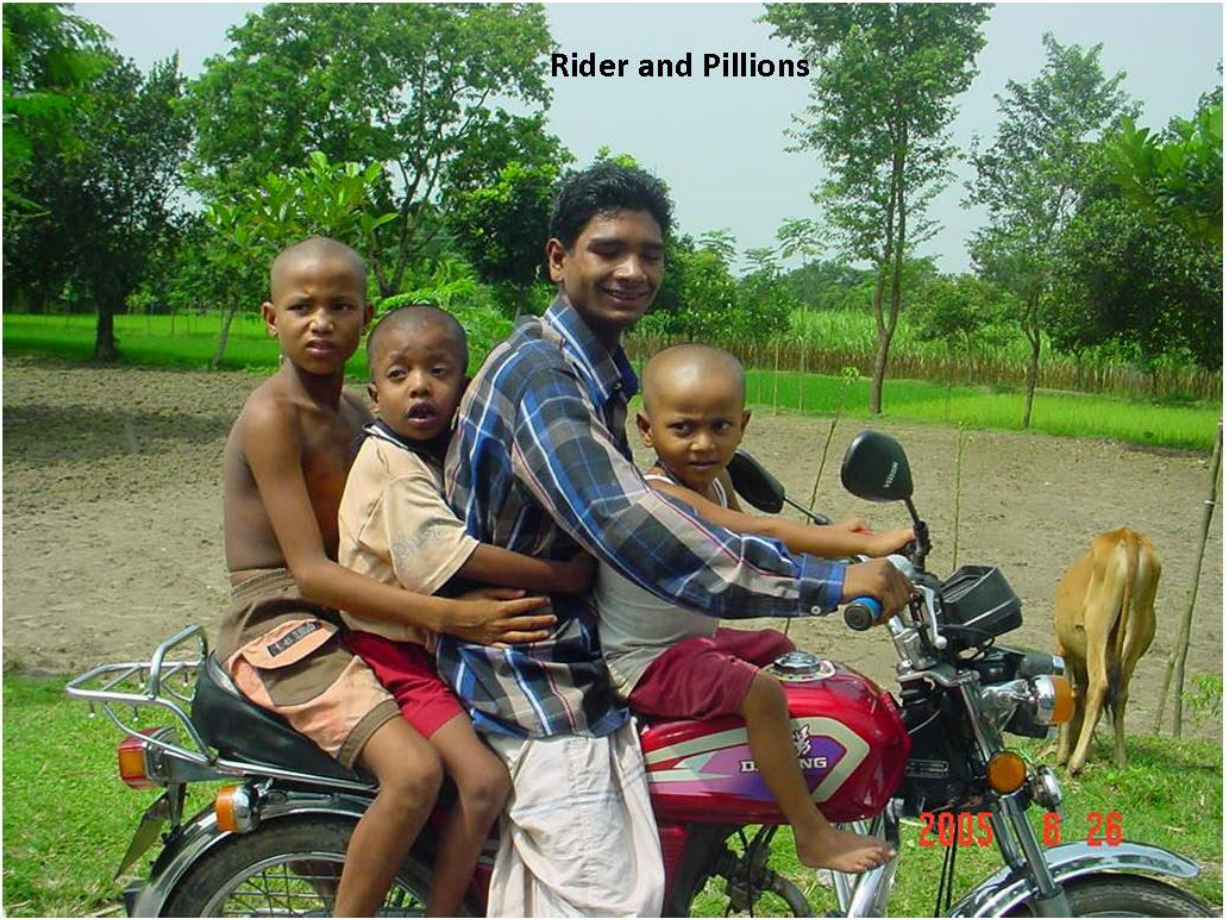

Rider and Pillions

2005 8 26



Pedestrians

2005 8 25



CE - 351

## Road–Traffic System

### ROADWAY ENVIRONMENT

Include elements which influence traffic operating condition:

- Roadway geometric conditions
  - Standard of road
  - Surface condition
  - Horizontal & vertical alignment
  
- Roadway operating conditions
  - Traffic control & regulation
  - Road side conditions
  - Lighting condition

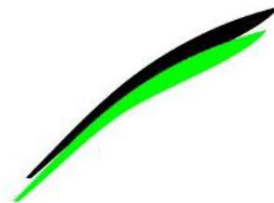

*Prof. Dr. Md. Shamsul Hoque*



# Traffic Characteristics



Prof. Dr. Md. Shamsul Hoque

## TRAFFIC CHARACTERISTICS



### Introduction

- Road is for traffic movements, as such roadway elements should be designed matching with the traffic characteristics
- Traffic characteristics affect roadway planning, design, improvement or operational aspects
- As such there is a need for proper understanding of the behavior of the road user and the vehicle characteristics
- Study of traffic characteristics include
  - Vehicular characteristics
  - Road User's Characteristics



Prof. Dr. Md. Shamsul Hoque

## TRAFFIC CHARACTERISTICS



### Vehicular Characteristics

- Generally, roadway geometry is designed based on specific standard vehicle that will enjoy safe driving and full level of service (LOS)
- A vehicle that represents the design standards is termed as **design vehicle**
- Characteristics of design vehicle actually fix all the dimensions of the road
- The vehicular characteristics can be classified as:
  - Static characteristics and
  - Dynamic characteristics.



Prof. Dr. Md. Shamsul Hoque

## TRAFFIC CHARACTERISTICS



### Static/physical Characteristics

- Axle load** - needed for structural design of
  - pavement
  - bridge/fly-over/grade separator etc.
- Width** - needed for fixing
  - lane width
  - shoulder width
  - width of parking bay etc.



Prof. Dr. Md. Shamsul Hoque

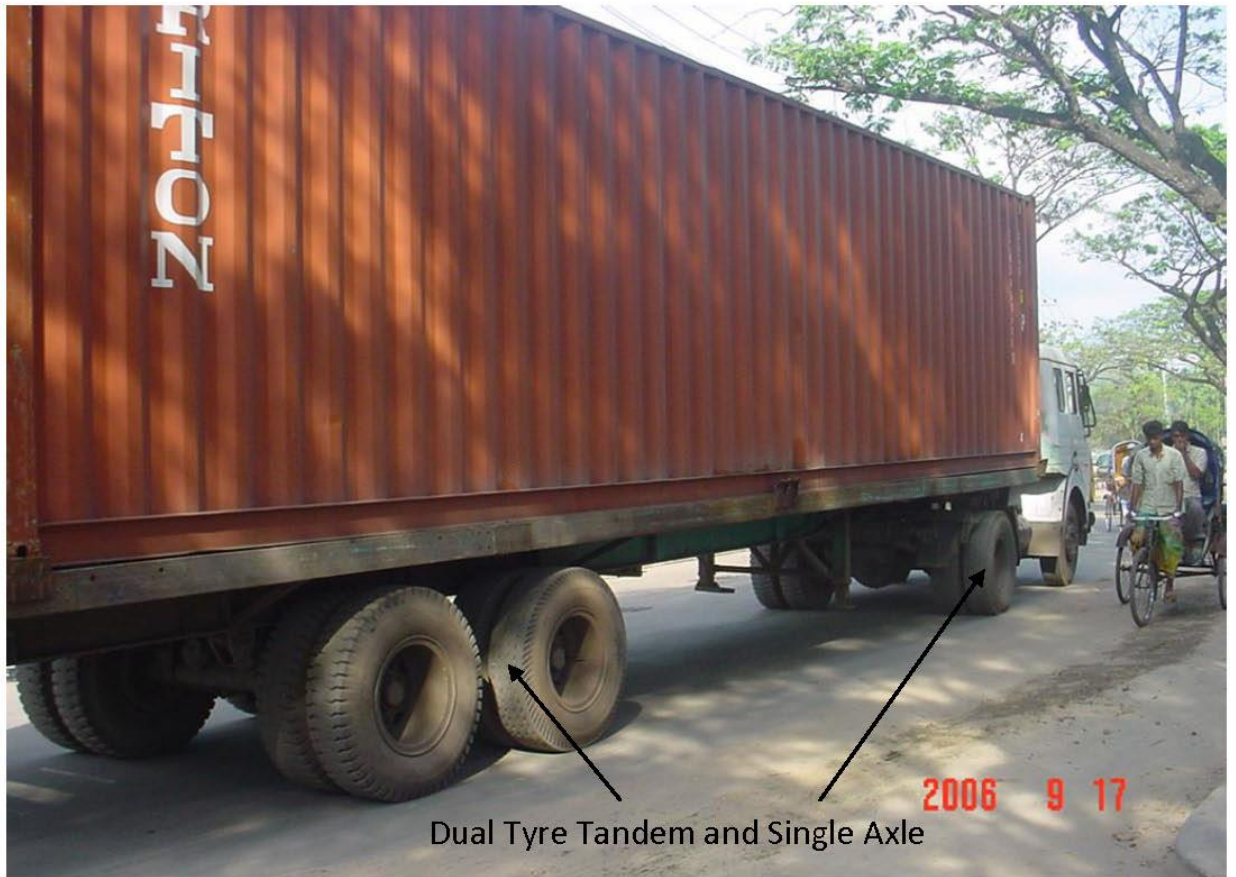

Dual Tyre Tandem and Single Axle



Single Tyre Trident Axle

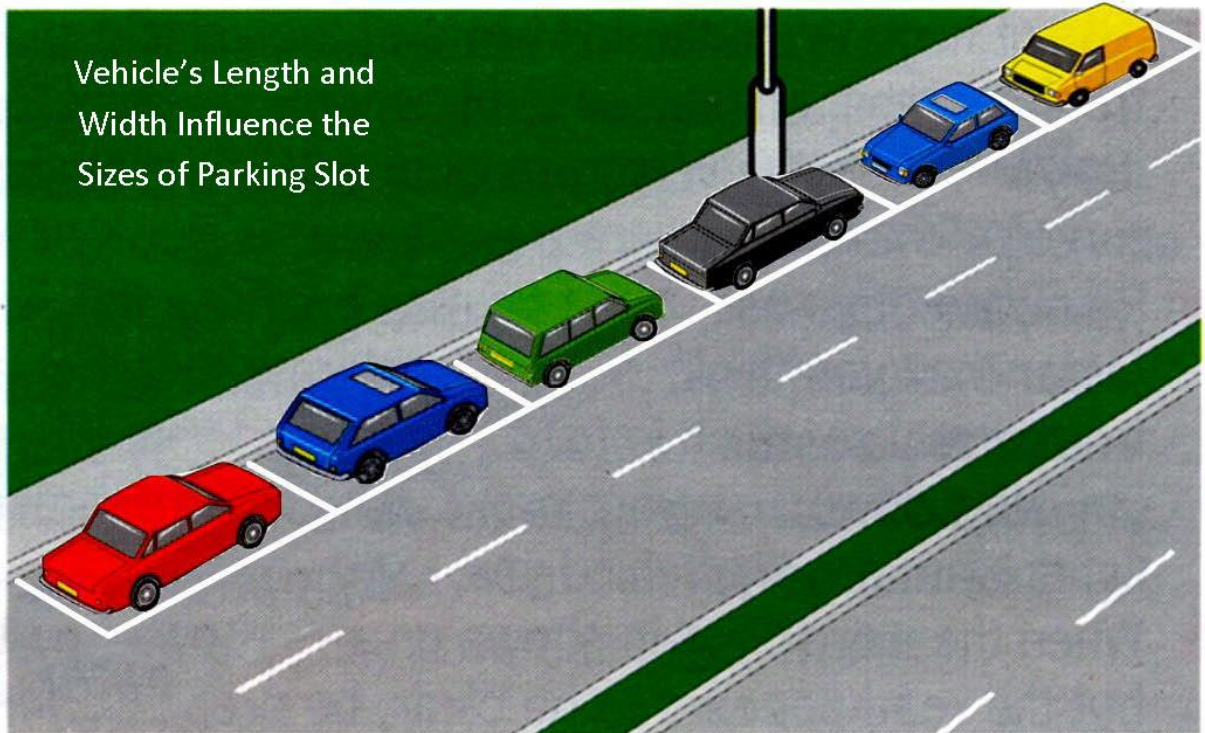

CE - 351

## TRAFFIC CHARACTERISTICS

### Static/physical Characteristics *Contd.....*

- Length** - needed for
  - fixing minimum turning radius & curve widening
  - calculating minimum passing sight distance
  - fixing size of parking bay & isle
  - designing bus lay-by and terminal facilities
- Height** - needed for fixing headroom under
  - fly-over, footbridge
  - sign-post gantry, electric/telephone lines etc.



Prof. Dr. Md. Shamsul Hoque

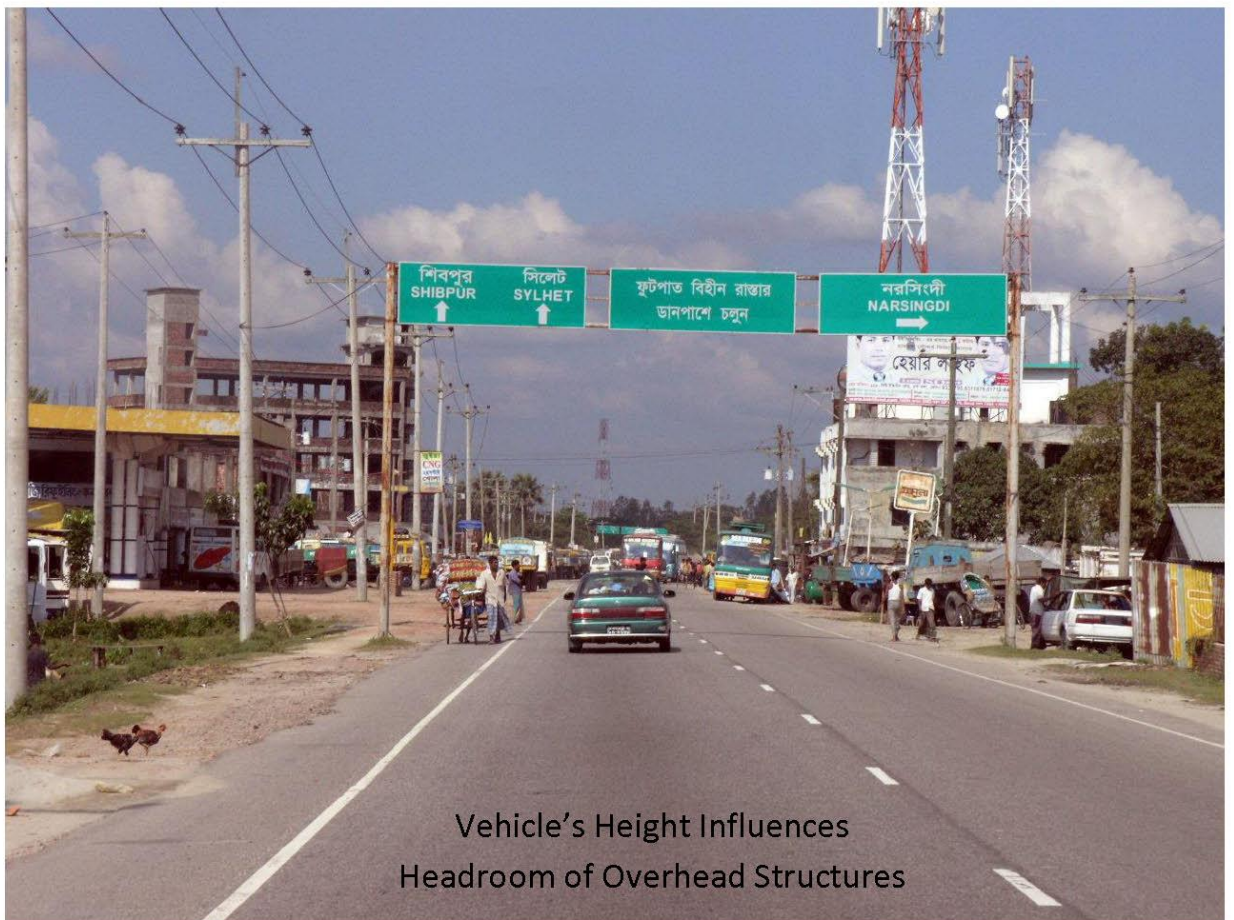

Vehicle's Height Influences  
Headroom of Overhead Structures

## TRAFFIC CHARACTERISTICS

### Dynamic Characteristics

Design Speed, Acceleration, Deceleration, Wt./Hp, Brake etc.

**Speed** - It is such a factor that controls most of the geometric standards of the highway viz.

- Horizontal and vertical alignment (i.e. fixing roadway curvatures and grades)
- Length of transition curve
- Super-elevation
- Stopping/overtaking sight distance
- Width of pavement on straight and curves
- Capacity/LOS
- Intersection design and control (fixing amber period, signal co-ordination, stop/giveway sign, etc. )
- Skid resistance etc.



Prof. Dr. Md. Shamsul Hoque

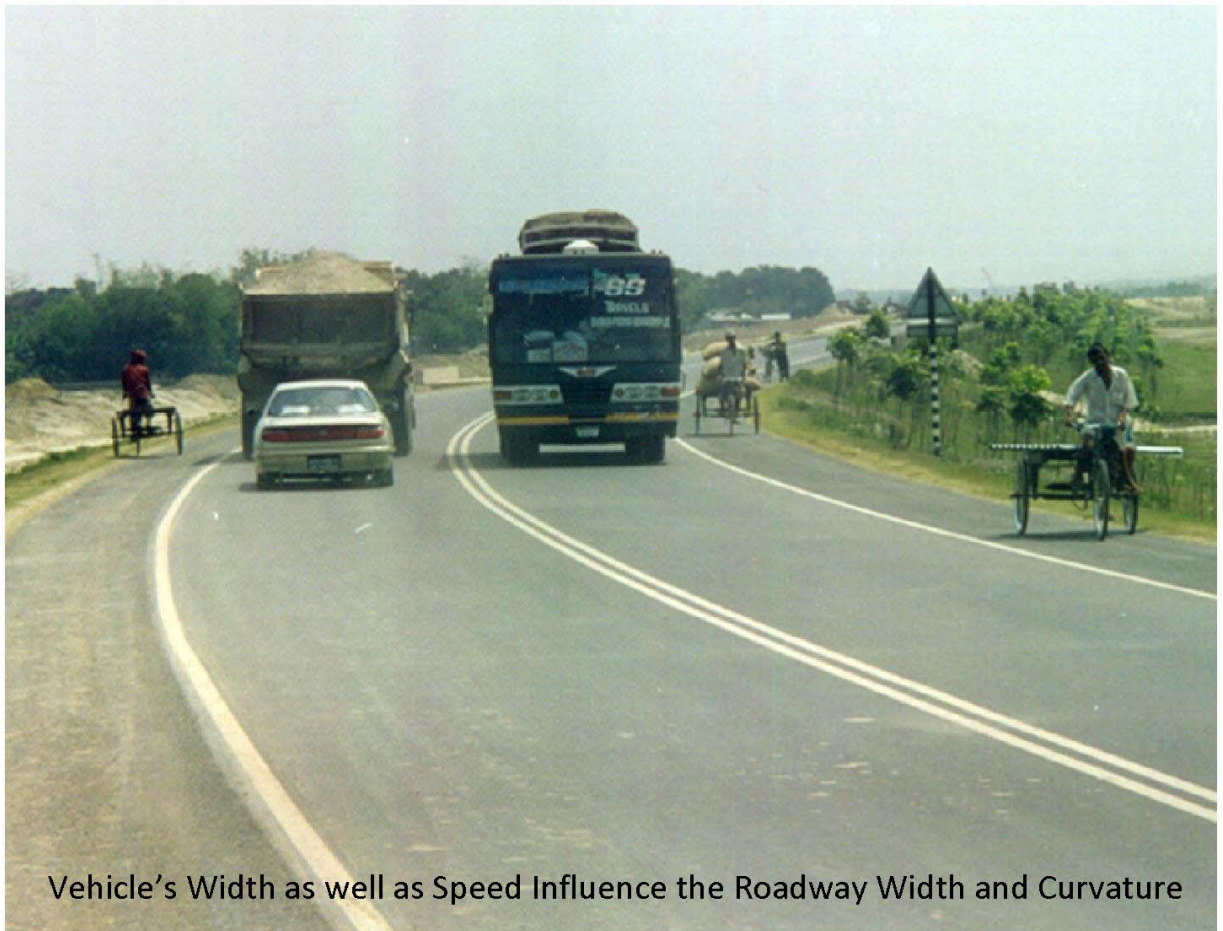

Vehicle's Width as well as Speed Influence the Roadway Width and Curvature

## TRAFFIC CHARACTERISTICS

### Road User's Characteristics

#### Introduction

- Road users e.g. pedestrians, riders and drivers are most complex and least understood element of roadway system.
- For proper functioning of roadway operation, road users' limitations and behavior must be understood and taken into account in all traffic engineering and design matters
- Over 90 per cent of all roadway accidents are due to road users' errors of judgment
- As such it is very important to study the factors which influence the manner and way at which errors occur



Prof. Dr. Md. Shamsul Hoque

## TRAFFIC CHARACTERISTICS

### Driver Characteristics :

How far they can see; How promptly they can react;  
How drivers behave (act); Attitude towards obeying rules & regulations -  
these are important for maintaining safer traffic operation.

Drivers' characteristics are involved:

- when they adjust speeds with changing roadway environment
- in making decisions while
  - turning/changing lane/overtaking/accepting critical gap etc.
  - face conflicting with the pedestrians
  - keeping safe headways with the leader
- in roadway sign/markings design (i.e. fixing letter height/size based on drivers depth of vision, color perception, speeds etc.)
- in street lighting design (i.e. fixing signal dia., establishing level of illumination depending on drivers' ability to see at night)
- in licensing control



Prof. Dr. Md. Shamsul Hoque

## TRAFFIC CHARACTERISTICS

### Factors Affecting Drivers Characteristics

The factors that affect the drivers' behavior are:

- Physical factors** - these include:
  - eye-sight/depth of vision
  - hearing power
  - other defects/disabilities
  - fatigue, alcohol or drugs, illness etc. are the temporary physical characteristics which affect reaction time, judgment time, alertness etc.
  
- Mental factors** - these include:
  - intelligence
  - education, skill, knowledge
  - experience/training of the drivers etc.
  
- Psychological factors** - these include:
  - impatience
  - attentiveness
  - attitude to follow regulations
  - maturity etc.



Prof. Dr. Md. Shamsul Hoque

## TRAFFIC CHARACTERISTICS

### Drivers' Reaction/PIEV Time

The time interval between seeing, hearing, or feeling, and the starting to do something in response to the stimulus of a traffic or highway situation is called "Reaction/PIEV time". Ideally, this response of the driver requires time for the following psychological process:

- P**erception - which involves seeing the stimuli along with other perceived objects
- I**dentification or intellection - which involves the identification and understanding of the stimuli
- E**motion or judgment - which involves the decision making process, in which a determination is made as to the proper course of action (to stop, pass, merge, cross, move laterally, or blow horn etc.)
- V**olition or reaction - which involves the execution of the decision



Prof. Dr. Md. Shamsul Hoque

## Minimum Stopping Distances

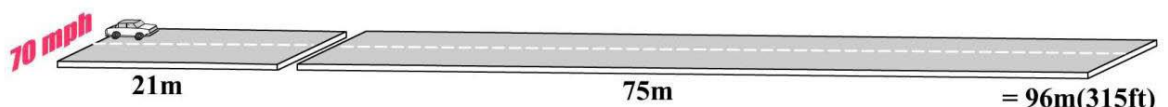
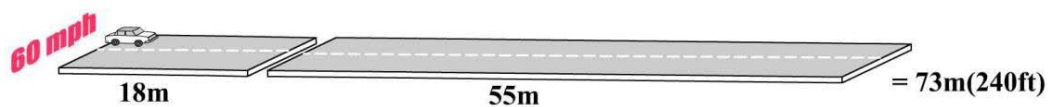
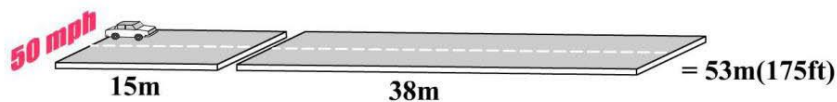
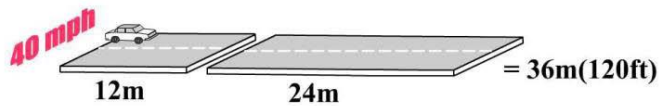
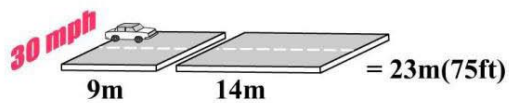
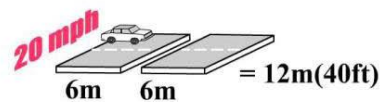

Thinking Distance    Breaking Distance

Note: SD depends on-

1. Tyre Condition
2. Road Surface Condition
3. Vehicle Speed etc.

CE - 351

## TRAFFIC CHARACTERISTICS

- PIEV time is required to determine
  - safe-stopping sight distance
  - safe approach speeds at intersection
  - amber/clearance time interval for traffic signals
  
- PIEV time varies from
  - about 0.5 sec for simple situations to
  - as much as 3 or 4 sec for more complex situations



Prof. Dr. Md. Shamsul Hoque

## TRAFFIC CHARACTERISTICS



- PIEV time increases with
  - complexity of situation; day/night
  - drivers'
    - age
    - physical deficiencies
    - ill mental/emotional/psychological conditions
  
- Besides above factors PIEV time also depends on
  - vehicle speed
  - location of roads (driving in built-up areas requires extra vigilance than driving in open areas)



*Prof. Dr. Md. Shamsul Hoque*

## TRAFFIC CHARACTERISTICS



### **Pedestrian Characteristics**

#### Introduction

- pedestrians are fully exposed most vulnerable road user group
  
- pedestrian are maneuverable and always with shortcut motive
  
- pedestrian actions are less predictable than those of drivers – as many pedestrians consider themselves “outside the law”
  
- they are hard to enforce
- pedestrians are more often disobey traffic control devices than are drivers
- need to be studied especially for urban road traffic system



*Prof. Dr. Md. Shamsul Hoque*

Absence of any Pedestrian Control Measure  
Encourages Pedestrians to make Random Crossing





Pedestrians are always difficult to Control



Pedestrians are always difficult to Control

## TRAFFIC CHARACTERISTICS



### Crossing Characteristics

- in general pedestrians tends to walk in a path that represents the shortest distance or most convenient route between two points
- they often cross at mid-block instead of using crosswalks
- they often cross wide road in a single attempt
- they don't voluntarily make use of special pedestrian facilities such as underpasses or overpasses

For that need self enforcing guiding measures viz. - Guard/Picket rail, Median barrier



Prof. Dr. Md. Shamsul Hoque



At Zebra Crossing, Picket Rails are used to Channelize Pedestrian Traffic as well as to Stop Random indiscipline crossings and Block Pavement with Rough Texture is used as Speed Calming Measure

2 6 2008

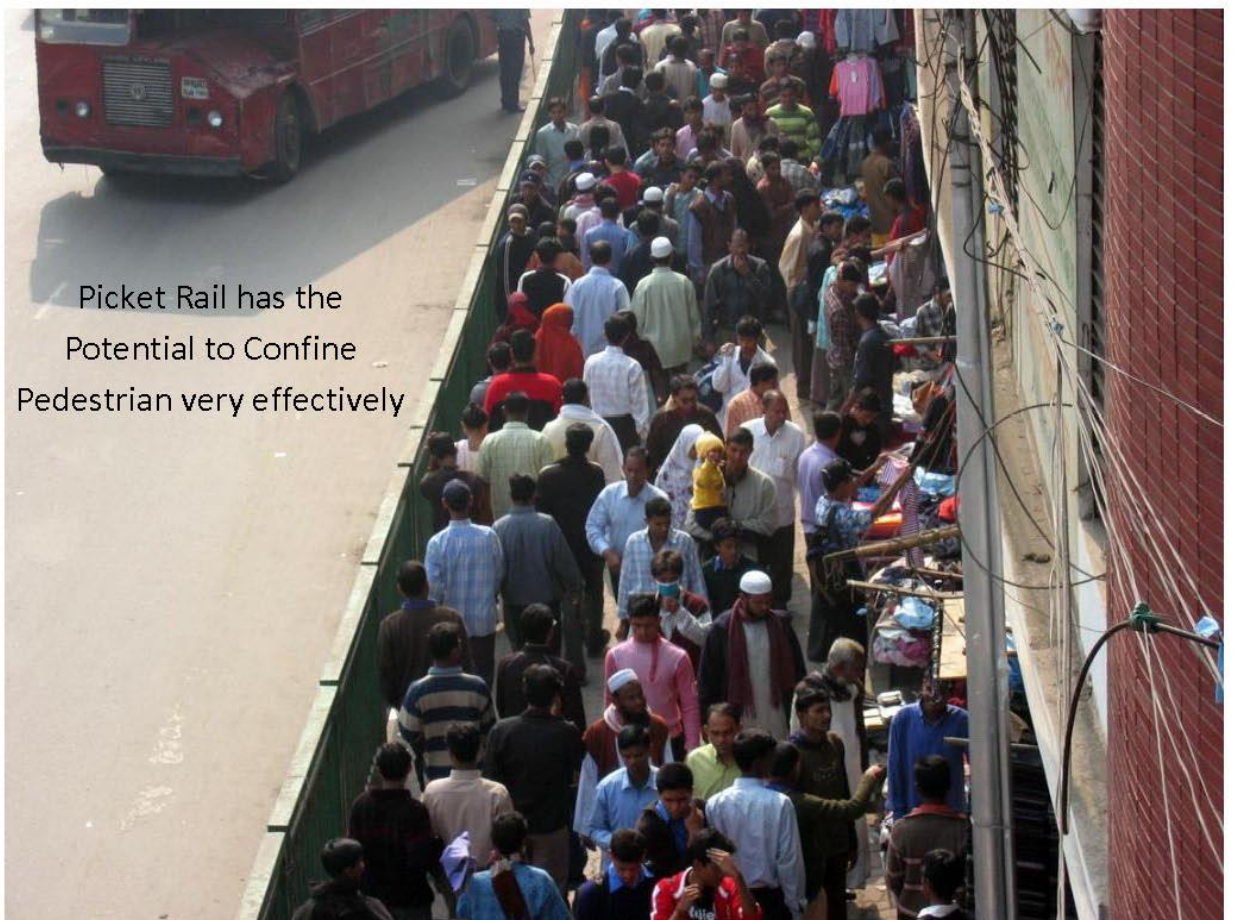

Picket Rail has the Potential to Confine Pedestrian very effectively

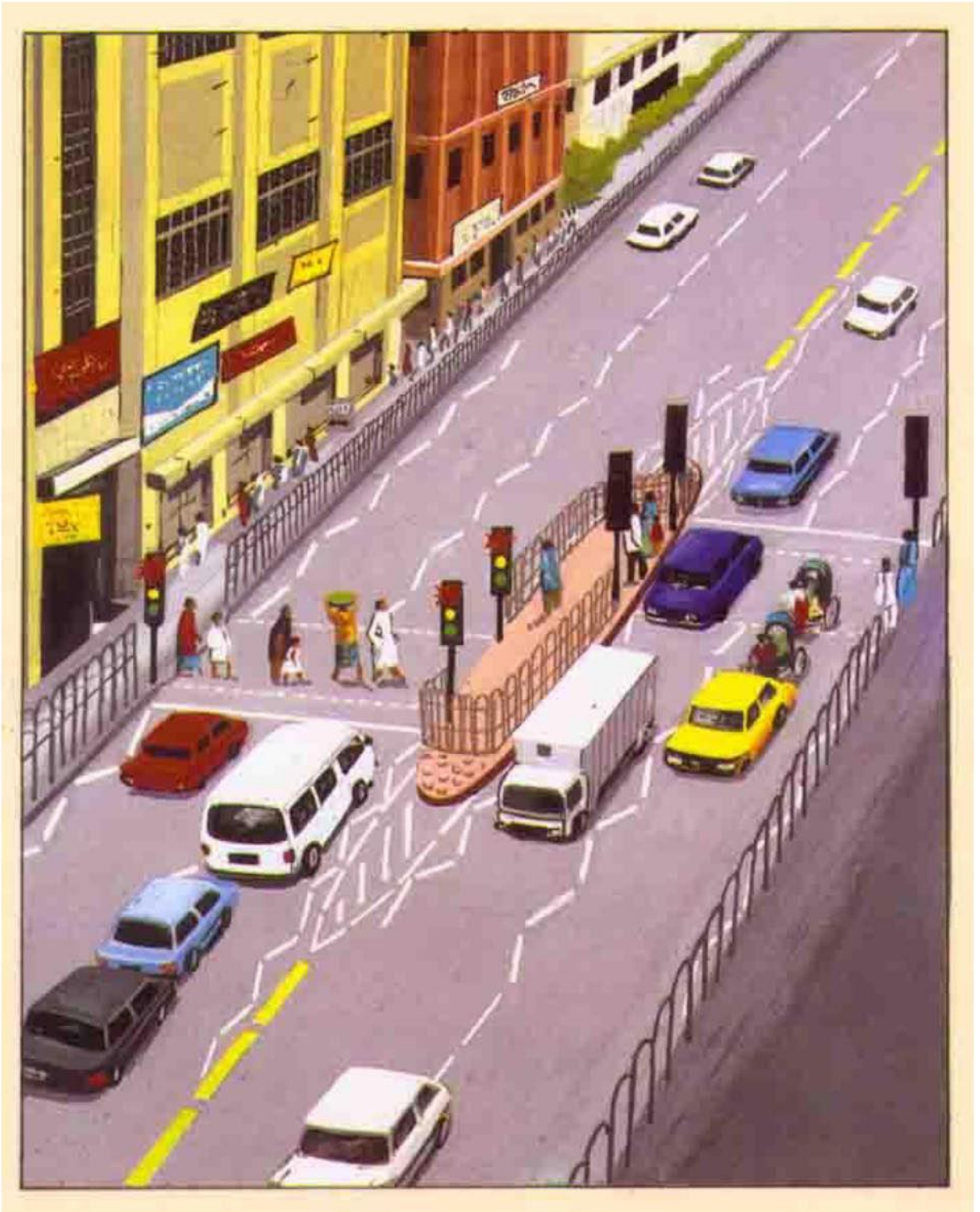

### **Staggered Pedestrian Crossing Arrangement**

(It is safer as it forces pedestrians to face on-coming traffic while crossing and also it does not allow anyone to cross the road hurriedly in a single attempt)