

CHAPTER – 5

Economical & Physical Justification For Canals

Dr. M. R. Kabir

Professor and Head, Department of Civil Engineering

University of Asia Pacific (UAP), Dhaka

LECTURE 12

Lining

Advantages of Lining:

- ✓ Seepage Control
- ✓ Prevention of Water-Logging
- ✓ Increase in Channel Capacity
- ✓ Increase in Commanded Area
- ✓ Reduction in Maintenance Costs
- ✓ Elimination of Flood Dangers

Selection of Suitable Type of Lining

- Low cost
- Impermeability
- Hydraulic efficiency (i.e. reduction in rugosity coefficient)
- Durability
- Resistance to erosion
- Repairability
- Structural stability

Financial Justification & Economics of Canal Lining

Annual benefits:

(a) Saved seepage water by lining:

Let, the rate of water is sold to the cultivators = Tk. R_1 /cumec

If m cumecs of water is saved by lining the canal annually, then the money saved by lining = Tk. $m R_1$

(b) Saving in maintenance cost:

Let, the average cost of annual upkeep of unlined channel = Tk. R_2

If p is the percentage fraction of the saving achieved in maintenance cost by lining the canal, then the amount saved = pR_2 Tk.

\therefore The total annual benefits = $mR_1 + p R_2$

Annual costs:

Let, the capital expenditure is C Tk. & the lining has a life of Y years

∴ Annual depreciation charges = C/Y Tk.

∴ Interest of the capital $C = C(r/100)$ [r = percent of the rate of annual interest]

∴ Average annual interest = $C/2(r/100)$ Tk.

[Since the capital value of the asset decreases from C to zero in Y years]

∴ The total annual costs of lining = $C/Y + C/2(r/100)$

$$\therefore \text{Benefit cost ratio} = \frac{\text{Annual Benefits}}{\text{Annual Costs}} = \frac{mR_1 + pR_2}{\frac{C}{Y} + \frac{C}{2} \times \frac{r}{100}}$$

If p is taken as 0.4, then

$$\therefore \text{Benefit cost ratio} = \frac{mR_1 + 0.4R_2}{\frac{C}{Y} + \frac{C}{2} \times \frac{r}{100}}$$

Problem

An unlined canal giving a seepage loss of 3.3 cumec per million square meters of wetted area is proposed to be lined with 10 cm thick cement concrete lining, which costs Tk. 180 per 10 square meters. Given the following data, work out the economics of lining and benefit cost ratio.

Annual revenue per cumec of water from all crops	Tk. 3.5 lakhs
Discharge in the channel	83.5 cumecs
Area of the channel	40.8 m ²
Wetted perimeter of the channel	18.8 m
Wetted perimeter of the lining	18.5 m
Annual maintenance cost of unlined channel per 10 square meter	Tk. 1.0

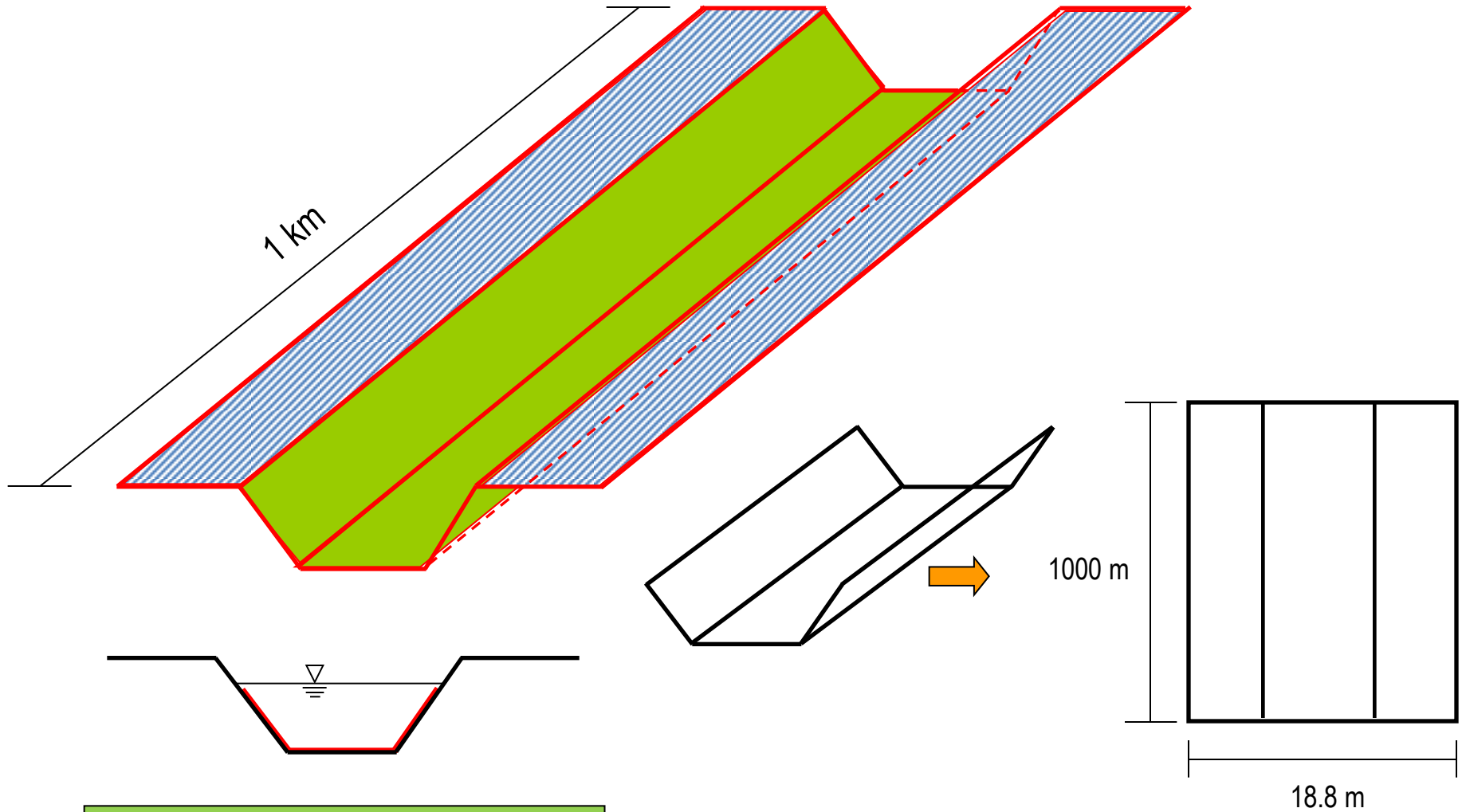

Discharge in the canal = 83.5 cumec
 Area of the canal = 40.8 m²
 Wetted Perimeter of the canal = 18.8 m
 Wetted Perimeter of the lined canal = 18.5 m

Solution:

Let us consider 1 km (= 1000 m) reach of canal. Therefore,

$$\text{the wetted surface per km} = 18.8 \times 1000 = 18,800 \text{ m}^2$$

(i) Annual Benefits

(a) Seepage loss

Seepage loss in unlined canal @ 3.3 cumec per million sq. m

$$= (3.3/10^6) \times 18,800 \text{ cumec/km} = 62,040 \times 10^{-6} \text{ cumec/km}$$

Assume, seepage loss in lined channel at 0.01 cumec per million square meter of wetted perimeter

$$\therefore \text{Seepage loss in unlined canal} = (0.01/10^6) \times 18,800 = 188 \times 10^{-6} \text{ cumecs/km}$$

$$\text{Net saving} = (62,040 \times 10^{-6} - 188 \times 10^{-6}) \text{ cumec/km} = 0.06185 \text{ cumec/km}$$

$$\text{Annual revenue saved per km of channel} = (0.06185 \times 3.5) \text{ lakhs}$$

$$= 0.21648 \text{ lakhs} = 21,648 \text{ Tk.}$$

(b) Saving in maintenance

Annual maintenance cost of unlined channel for $10 \text{ m}^2 = \text{Tk.}1$

Total wetted perimeter per 1 km length = $18,800 \text{ m}^2$

\therefore Annual maintenance charge for unlined channel/ km = $\text{Tk.}1,880$

Assume that 40% of this is saved in lined channel

Annual saving in maintenance charges = $\text{Tk.} (0.4 \times 1880) = \text{Tk.}752$

\therefore Total annual benefits per km = $\text{Tk.} (21,648 + 752) = \text{Tk.}22,400$

(ii) Annual Costs

Area of lining per km of channel = $18.5 \times 1000 = 18500 \text{ m}^2$

Cost of lining per km of channel @ Tk. 180 per 10 m^2

$$= (18500 \times 180 / 10) \text{ Tk.} = 333000 \text{ Tk.}$$

Assume, life of lining as 40 years

Depreciation cost per year = Tk. $(3,33,000 / 40) = \text{Tk. } 8325$

Assume 5% rate of interest

Average annual interest = $C/2 (r/100) = 3,33,000/2 \times (5/100) = \text{Tk. } 8325$

$$\therefore \text{Total annual cost} = \text{Tk } (8325 + 8325) = \text{Tk. } 16,650$$

Benefit cost ratio = Annual benefits/Annual costs = $22,400/16,650 = 1.35$

Benefit cost ratio is **more than unity**, and hence, the lining is justified.

LECTURE 13

Causes of failure of weir or barrage on permeable foundation

❑ ***Failure due to Subsurface Flow***

- (a) Failure by Piping or Undermining
- (b) Failure by Direct Uplift

❑ ***Failure by Surface Flow***

- (a) By Hydraulic Jump
- (b) By Scouring

(a) Failure by Piping or undermining

The water from the upstream side continuously percolates through the bottom of the foundation and emerges at the downstream end of the weir or barrage floor. The force of percolating water removes the soil particles by scouring at the point of emergence.

(b) Failure by Direct uplift

The percolating water exerts an upward pressure on the foundation of the weir or barrage. If this uplift pressure is not counterbalanced by the self weight of the structure, it may fail by rapture.

(a) Failure by Hydraulic Jump

When the water flows with a very high velocity over the crest of the weir or over the gates of the barrage, then hydraulic jump develops. This hydraulic jump causes a suction pressure or negative pressure on the downstream side which acts in the direction uplift pressure. If the thickness of the impervious floor is sufficient, then the structure fails by rapture.

(b) Failure By Scouring

During floods, the gates of the barrage are kept open and the water flows with high velocity. The water may also flow with very high velocity over the crest of the weir. Both the cases can result in scouring effect on the downstream and on the upstream side of the structure. Due to scouring of the soil on both sides of the structure, its stability gets endangered by shearing.

Bligh's creep theory for seepage flow

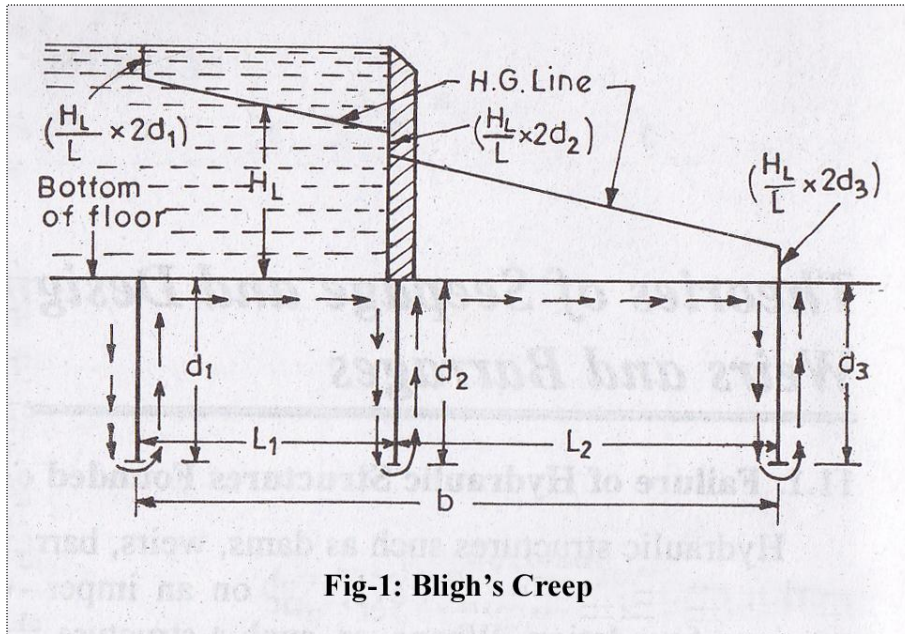

Head losses equal to $\left(\frac{H_L}{L} \times 2d_1\right)$
 $\left(\frac{H_L}{L} \times 2d_2\right)$ $\left(\frac{H_L}{L} \times 2d_3\right)$; will occur
 respectively, in the planes of three
 vertical cut offs. The hydraulic
 gradient line (H.G. Line) can then be
 drawn as shown in figure aside.

$$L = d_1 + d_1 + L_1 + d_2 + d_2 + L_2 + d_3 + d_3 = (L_1 + L_2) + 2(d_1 + d_2 + d_3)$$

$$= b + 2(d_1 + d_2 + d_3)$$

$$\text{Head loss per unit length or hydraulic jump} = \left[\frac{H_L}{b + 2(d_1 + d_2 + d_3)} \right] = \frac{H_L}{L}$$

(i) Safety against piping or undermining

By providing sufficient creep length, given by $L = C H_L$

Where C is the Bligh's Coefficient for the soil.

Different values of C for different types of soils are tabulated in the table below:

SL	Type of Soil	Value of C	Safe Hydraulic gradient should be less than
1	Fine Sand	15	1/15
2	Coarse Grained Sand	12	1/12
3	Sand mixed with boulder and gravel, and for loam soil	5 to 9	1/5 to 1/9
4	Light Sand and Mud	8	1/8

(i) Safety against uplift pressure

The ordinates of the H.G line above the bottom of the floor represent the residual uplift water head at each point. Say for example, if at any point, the ordinate of H.G line above the bottom of the floor is 1 m, then 1 m head of water will act as uplift at that point. If h' meters is this ordinate, then water pressure equal to h' meters will act at this point, and has to be counterbalanced by the weight of the floor of thickness say t .

$$\therefore \text{Uplift pressure} = \gamma_w \quad h'$$

[where γ_w is the unit weight of water]

$$\text{Downward pressure} = (\gamma_w \quad G).t$$

[Where G is the specific gravity of the floor material]

For equilibrium,

$$\gamma_w \quad h' = (\gamma_w \quad G).t$$
$$\Rightarrow h' = G \quad t$$

Subtracting t on both sides, we get

$$(h' - t) = (G - 1)t = t(G - 1)$$

$$\Rightarrow t = \left(\frac{h' - t}{G - 1} \right) = \left(\frac{h}{G - 1} \right)$$

Where, $h' - t = h =$ Ordinate of the H.G line above the top of the floor

$G - 1 =$ Submerged specific gravity of the floor material

Lane's weighted creep theory

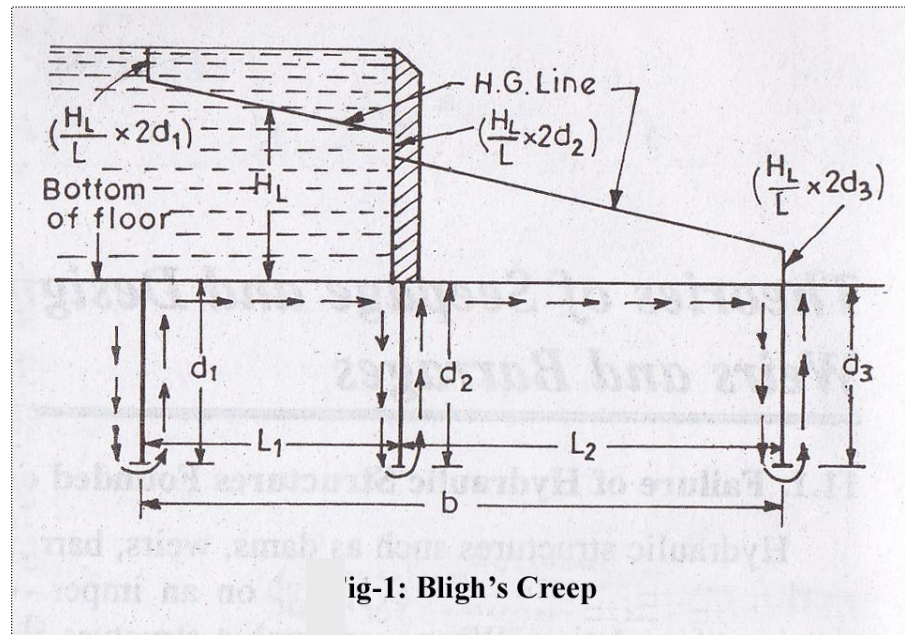

Weightage factor of $\frac{1}{3}$ for the horizontal creep, as against 1.0 for the vertical creep

$$\begin{aligned}
 L_c &= (d_1 + d_1) + \left(\frac{1}{3}\right) L_1 + (d_2 + d_2) + \left(\frac{1}{3}\right) L_2 + (d_3 + d_3) \\
 &= \left(\frac{1}{3}\right) (L_1 + L_2) + 2(d_1 + d_2 + d_3) \\
 &= \left(\frac{1}{3}\right) b + 2(d_1 + d_2 + d_3)
 \end{aligned}$$

Khosla's theory and concept of flow

Main principles of Khosla's theory:

- **Stream Lines:** The streamlines represent the paths along which the water flows through the sub-soil.
- Every particle entering the soil at a given point upstream of the work, will trace out its own path and will represent a streamline.
- The first streamline follows the bottom contour of the works and is the same as Bligh's path of creep.
- The remaining streamlines follows smooth curves transiting slowly from the outline of the foundation to a semi-ellipse, as shown below.

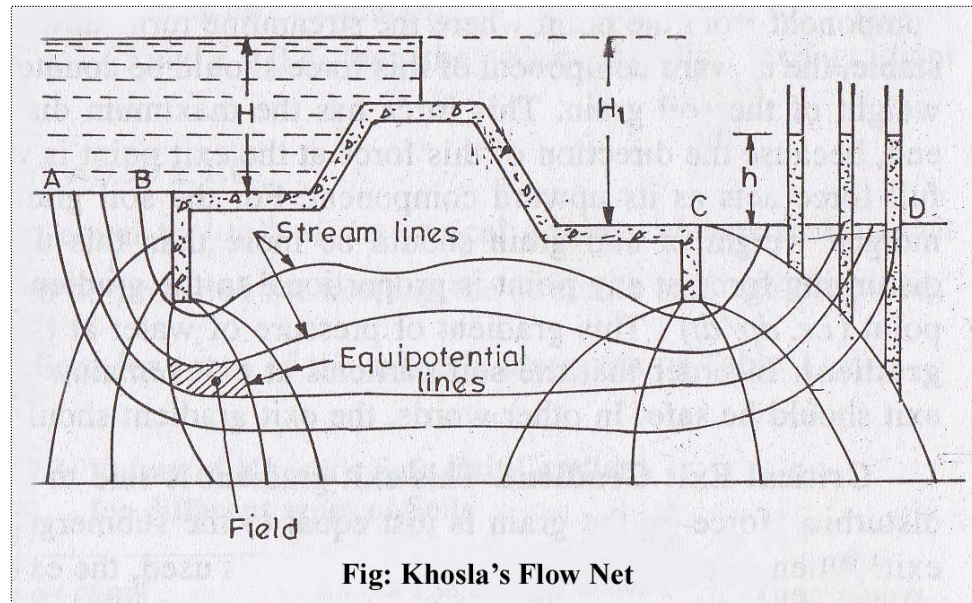

Khosla's method of independent variables

(For determination of pressures and exit gradient)

- ❑ To know the seepage below the foundation of a hydraulic structure, it is necessary to plot the flow net.
- ❑ In other words, we must solve the Laplacian equations.
- ❑ This can be accomplished either by
 - (i) Mathematical solution of Laplacian equations,
 - (ii) Electrical analogy method,
 - (iii) Graphical sketching

These are **complicated methods and are time consuming**.

For designing hydraulic structures such as weirs or barrage or pervious foundations, Khosla has evolved a simple, quick and an accurate approach, called **Method of Independent Variables**.

The simple profiles which are most useful are:

- ✓ A straight horizontal floor of negligible thickness with a sheet pile line on the upstream end and downstream end.
- ✓ A straight horizontal floor depressed below the bed but without any vertical cut-offs.
- ✓ A straight horizontal floor of negligible thickness with a sheet pile line at some intermediate point.

Three corrections in Khosla's theory

- a) Correction for the Mutual interference of Piles
- b) Correction for the thickness of floor
- c) Correction for the slope of the floor

(a) Correction for the Mutual Interference of Piles:

$$C = 19 \sqrt{\frac{D}{b'}} \left(\frac{d + D}{b} \right)$$

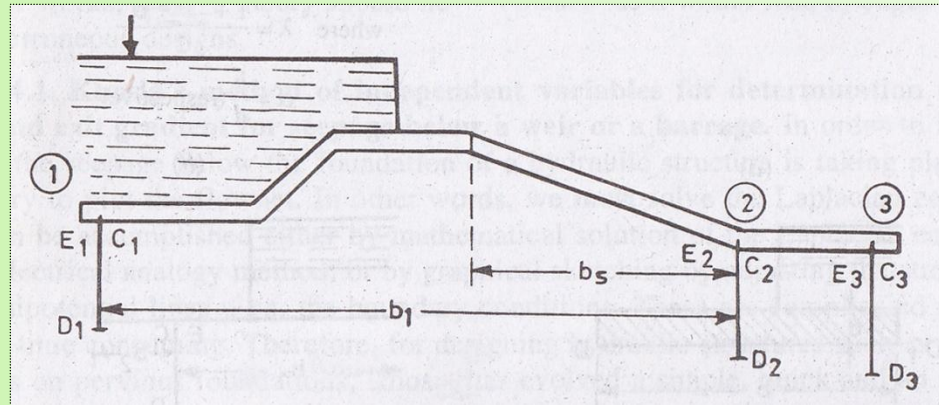

Where,

- b' = The distance between two pile lines
- D = The depth of the pile line, the influence of which has to be determined on the neighboring pile of depth d . (D is to be measured below the level at which interference is desired.)
- d = The depth of the pile on which the effect is considered
- b = Total floor length

Suppose in the above figure, we are considering the influence of the pile No. (2) on pile No. (1) for correcting the pressure at C_1 . Since the point C_1 is in the rear, this correction shall be **positive**. While the correction to be applied to E_2 due to pile No. (1) shall be negative, since the point E_2 is in the forward direction of flow. Similarly, the correction at C_2 due to pile No. (3) is positive, and the correction at E_2 due to pile No. (2) is **negative**

(b) Correction for thickness of floor:

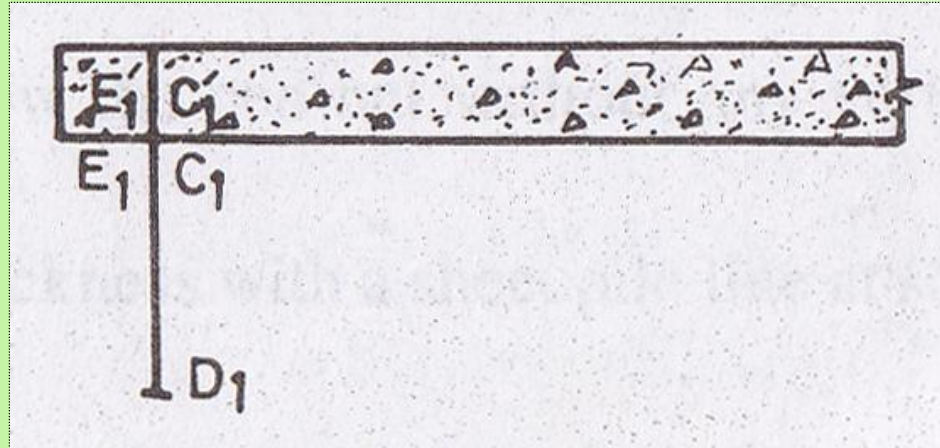

- The corrected pressure at E_1 should be less than the calculated pressure at E_1 '
- The correction to be applied for the joint E_1 shall be **negative**.
- The pressure calculated C_1 ' is less than the corrected pressure at C_1
- The correction to be applied at point C_1 is **positive**.

(c) Correction for the slope of the floor:

The correction factor given in the table below is to be multiplied by the **horizontal length of the slope** and divided by the **distance between the two pile lines** between which the sloping floor is located.

This correction is applicable only to the key points of the pile line fixed at the start or the end of the slope.

- Positive for down slope
- Negative for up slope

Slope (H : V)	Correction Factor
1 : 1	11.2
2 : 1	6.5
3 : 1	4.5
4 : 1	3.3
5 : 1	2.8
6 : 1	2.5
7 : 1	2.3
8 : 1	2.0

Exit gradient (G_E)

Gradient at the exit end is called exit gradient (G_E) which is determined from the equation below:

$$G_E = \frac{H}{d} \times \frac{1}{\pi\sqrt{\lambda}}$$

$$\text{Where, } \lambda = \frac{1 + \sqrt{1 + \alpha^2}}{2}$$

$$\alpha = b/d$$

H = Max. Seepage Head

Where, $\frac{1}{\pi\sqrt{\lambda}}$ is determined from the Plate No. 2 which is given in the next slide

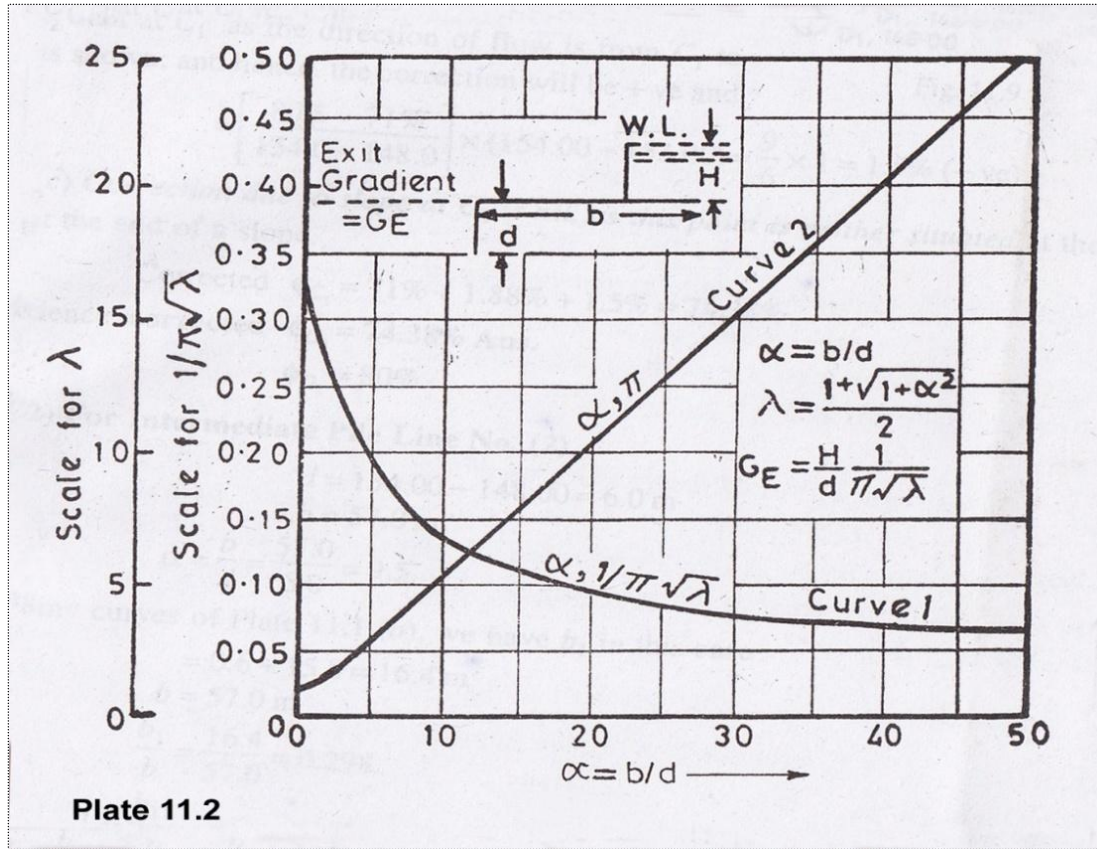

Type of Soil	Safe exit gradient
Shingle	1/4 to 1/5
Coarse Sand	1/5 to 1/6
Fine Sand	1/6 to 1/7

LECTURE 14

Problem: Determine the percentage pressures at various key points in figure below. Also determine the exit gradient and plot the hydraulic gradient line for pond level on upstream and no flow on downstream

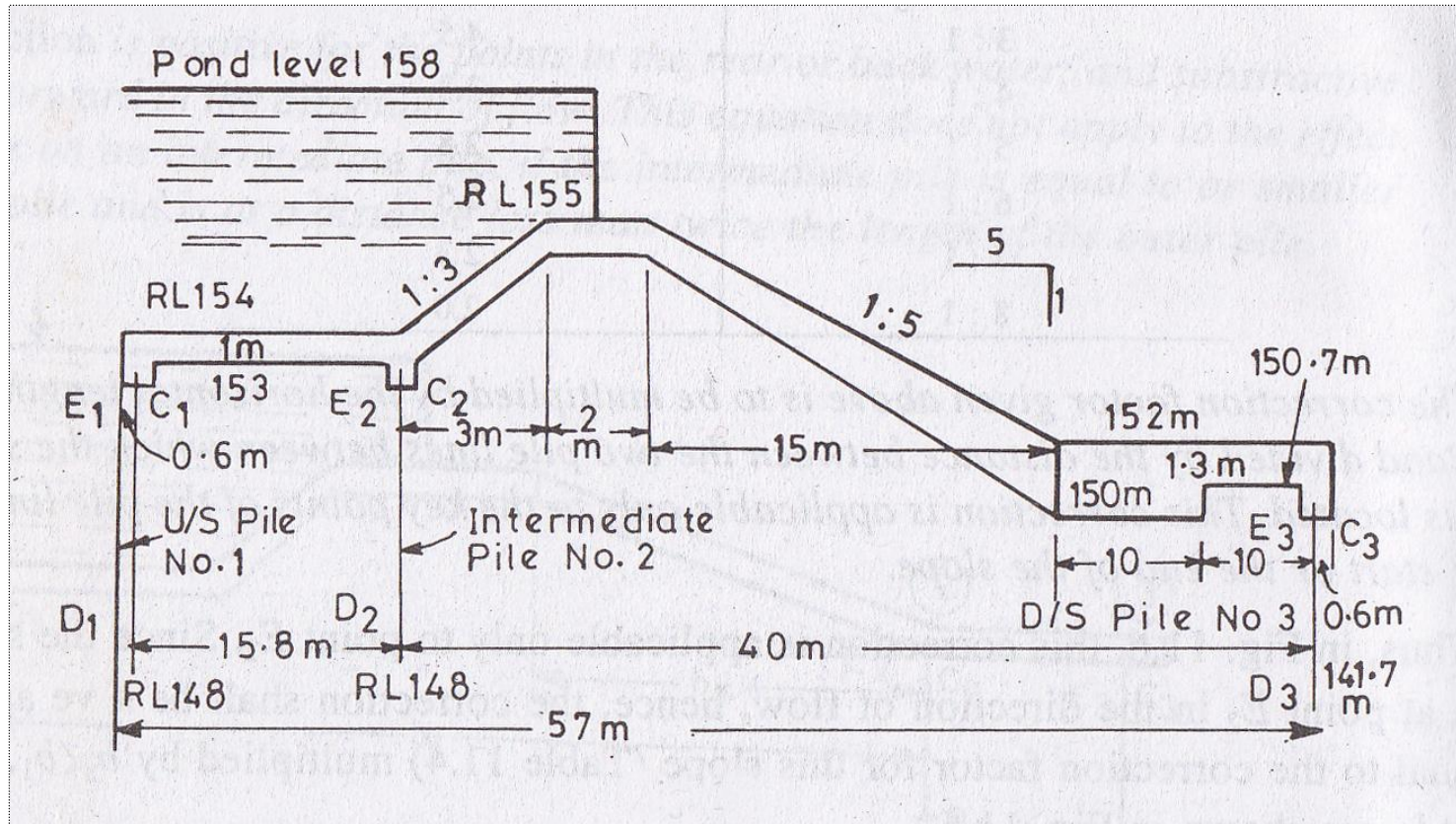

Khosla's Pressure Curves

Plate 11-1(a)

$$\alpha_1 = \frac{b_1}{d}$$

$$\alpha_2 = \frac{b_2}{d}$$

Sheet pile not at end

$$\phi_E = (1/\pi) \cos^{-1} \left(\frac{\lambda_1 - 1}{\lambda} \right)$$

$$\phi_C = (1/\pi) \cos^{-1} \left(\frac{\lambda_1 + 1}{\lambda} \right)$$

$$\phi_D = (1/\pi) \cos^{-1} \left(\frac{\lambda_1}{\lambda} \right)$$

To find ϕ_E for any value of α and base ratio b_1/b_2 , read ϕ_C for base ratio $(1-b_1/b_2)$ for that value of α and subtract from 100

Thus ϕ_E for $b_1/b_2 = 0.4$ and $\alpha = 4$, $= 100 - \phi_C$ for $b_1/b_2 = 0.6$ and $\alpha = 4$, $= 100 - 29.1 = 70.9\%$

To get ϕ_D for values of b_1/b_2 less than 0.5 read ϕ_D for base ratio $(1-b_1/b_2)$ and subtract from 100

Thus ϕ_D for $b_1/b_2 = 0.4$ and $\alpha = 4$
 $= 100 - \phi_D$ for $b_1/b_2 = 0.6$ and $\alpha = 4$
 $= 100 - 44.8 = 55.2$

$$\lambda_1 = \frac{\sqrt{1+\alpha^2} - \sqrt{1+\alpha_2^2}}{2}$$

$$\lambda = \frac{\sqrt{1+\alpha^2} + \sqrt{1+\alpha_2^2}}{2}$$

$$\alpha = \text{infinity}$$

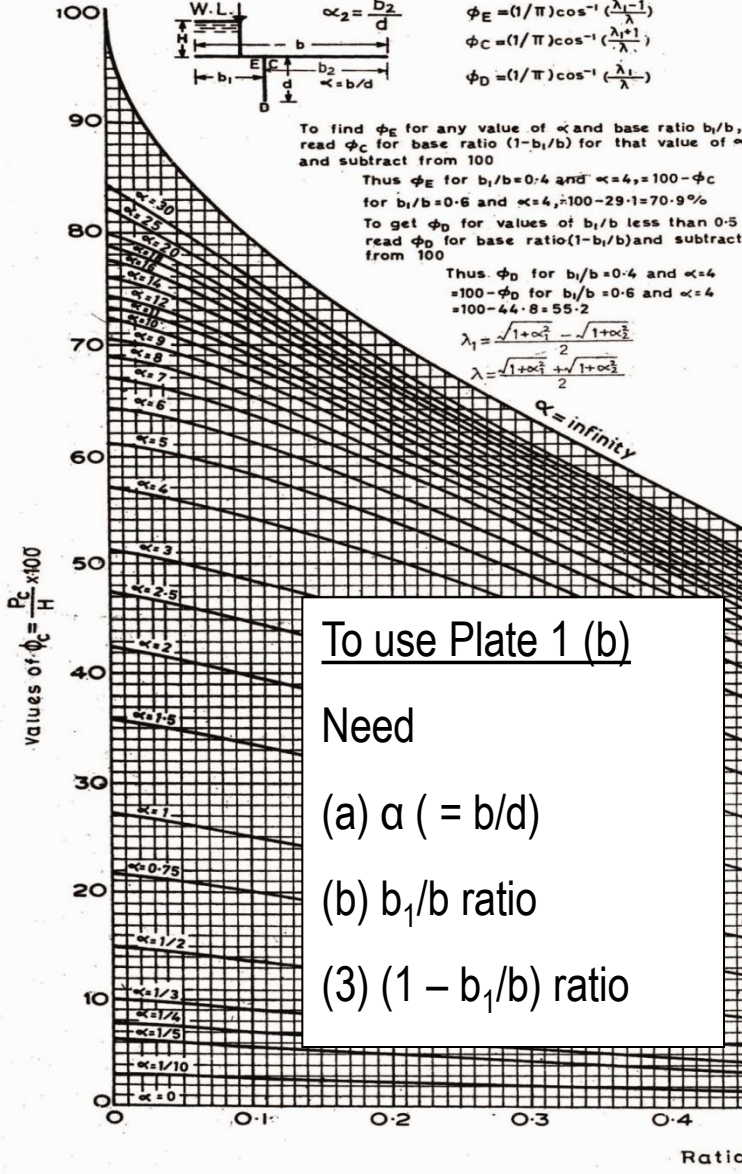

To use Plate 1 (b)
 Need
 (a) $\alpha (= b/d)$
 (b) b_1/b ratio
 (3) $(1 - b_1/b)$ ratio

Values of $1/\alpha = d/b$

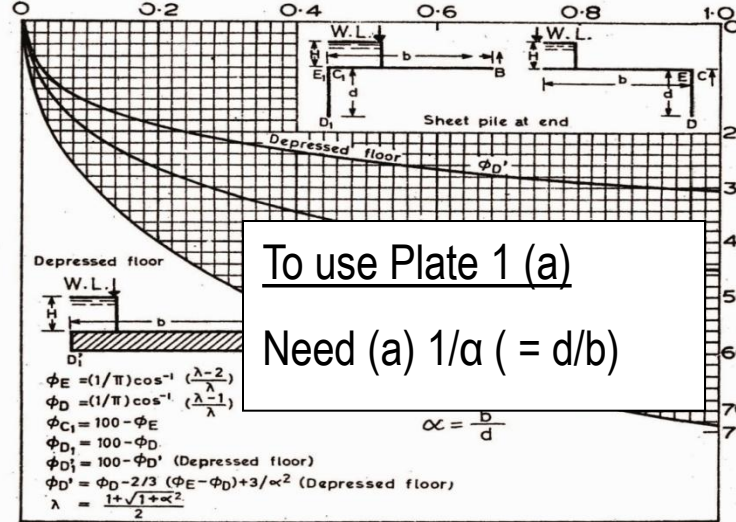

To use Plate 1 (a)
 Need (a) $1/\alpha (= d/b)$

$$\phi_E = (1/\pi) \cos^{-1} \left(\frac{\lambda - 2}{\lambda} \right)$$

$$\phi_D = (1/\pi) \cos^{-1} \left(\frac{\lambda - 1}{\lambda} \right)$$

$$\phi_{C1} = 100 - \phi_E$$

$$\phi_{D1} = 100 - \phi_D$$

$$\phi_{D1}' = 100 - \phi_{D1} \text{ (Depressed floor)}$$

$$\phi_{D1}'' = \phi_{D1} - 2/3 (\phi_E - \phi_{D1}) + 3/\alpha^2 \text{ (Depressed floor)}$$

$$\lambda = \frac{1 + \sqrt{1 + \alpha^2}}{2}$$

$$\alpha = \frac{b}{d}$$

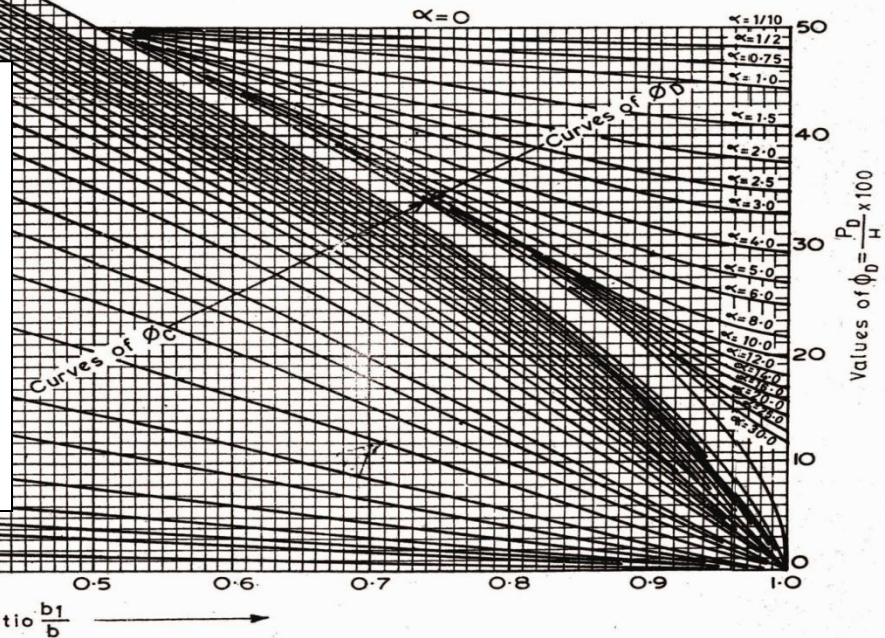

For calculating **intermediate pile pressure**, use plate 1 (a)

Plate 1 (a)

To use Plate 1 (a)
Need (a) $1/\alpha$ ($= d/b$)

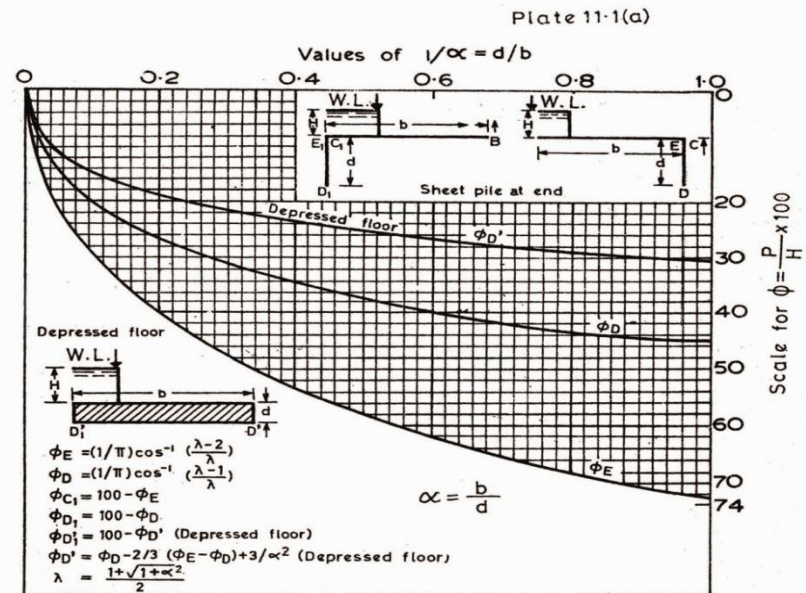

For calculating **starting or end pile pressure**, use plate 1 (a)

Plate 1 (b)

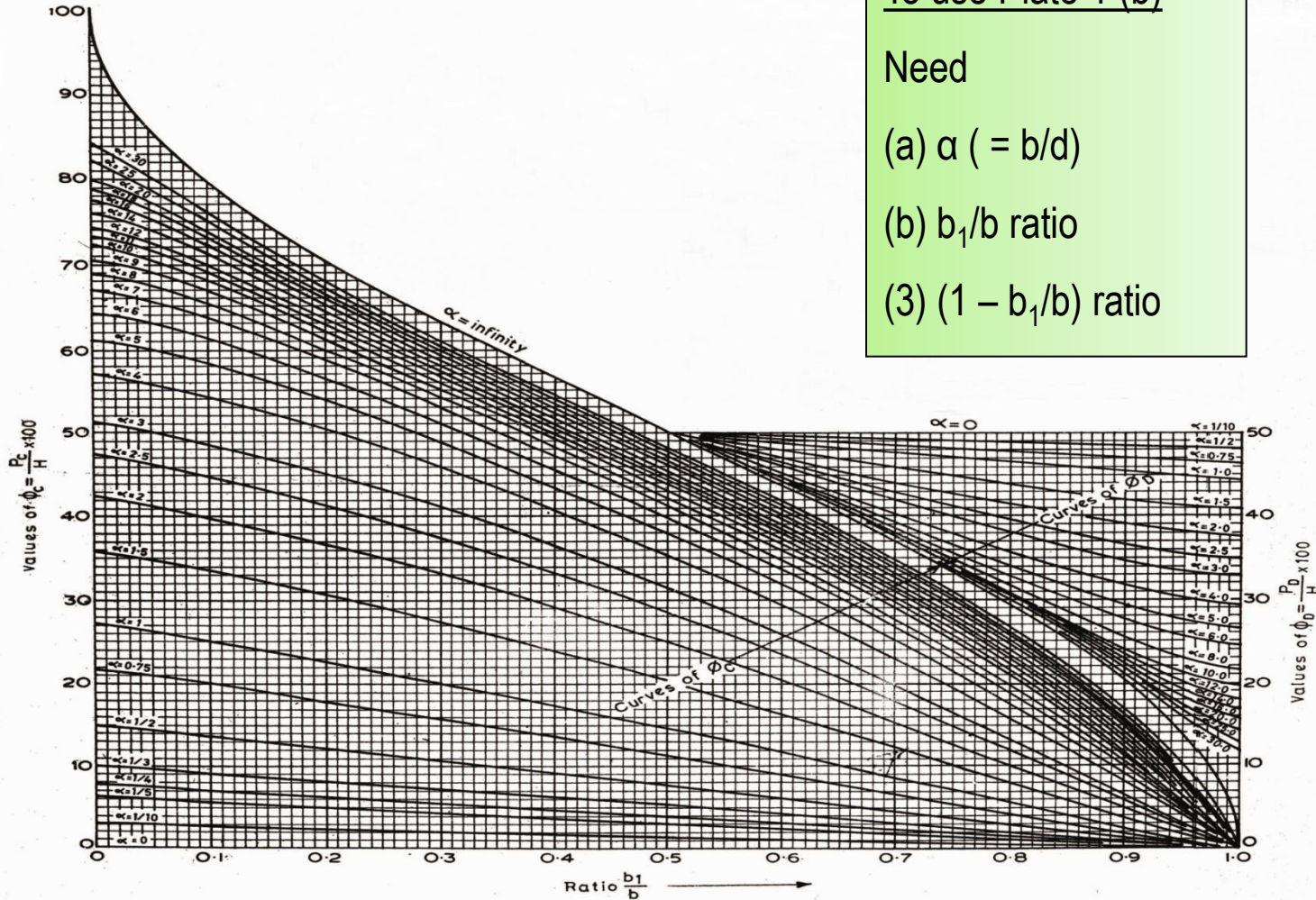

To use Plate 1 (b)

Need

(a) $\alpha (= b/d)$

(b) b_1/b ratio

(3) $(1 - b_1/b)$ ratio

For calculating **exit gradient** , use Plate 2

Plate 2

To use Plate 2

Need

$\alpha (= b/d)$ value and read curve 1 ($1/\pi\sqrt{\lambda}$)

Exit Gradient:

$$G_E = H/d \times 1/\pi\sqrt{\lambda}$$

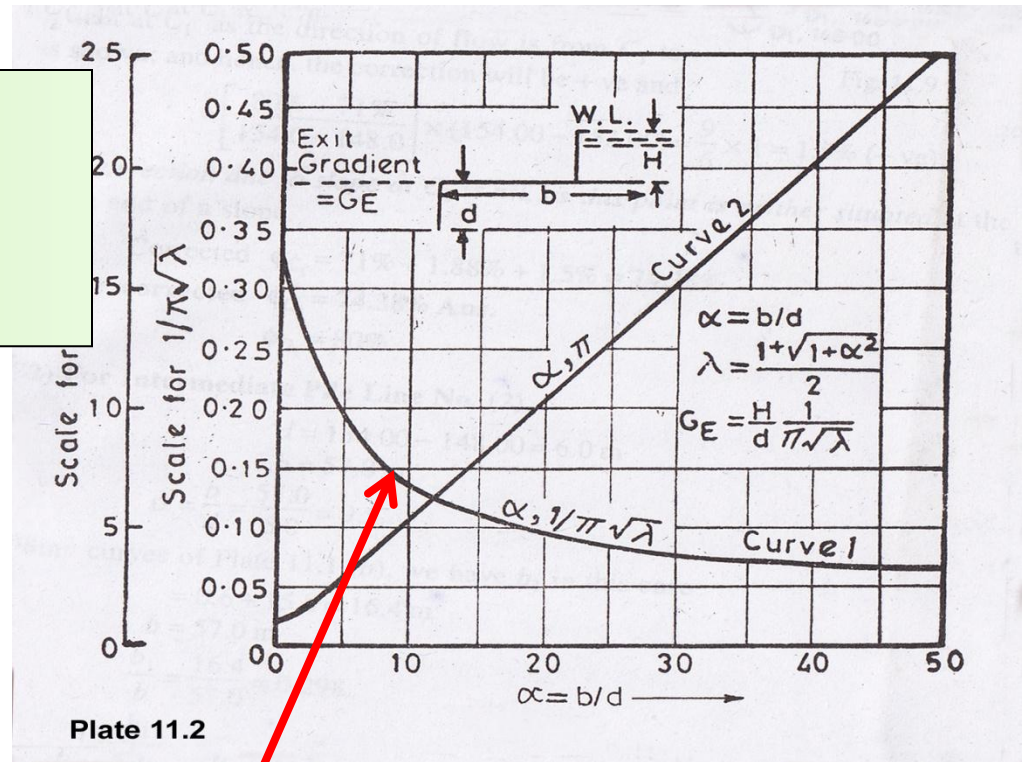
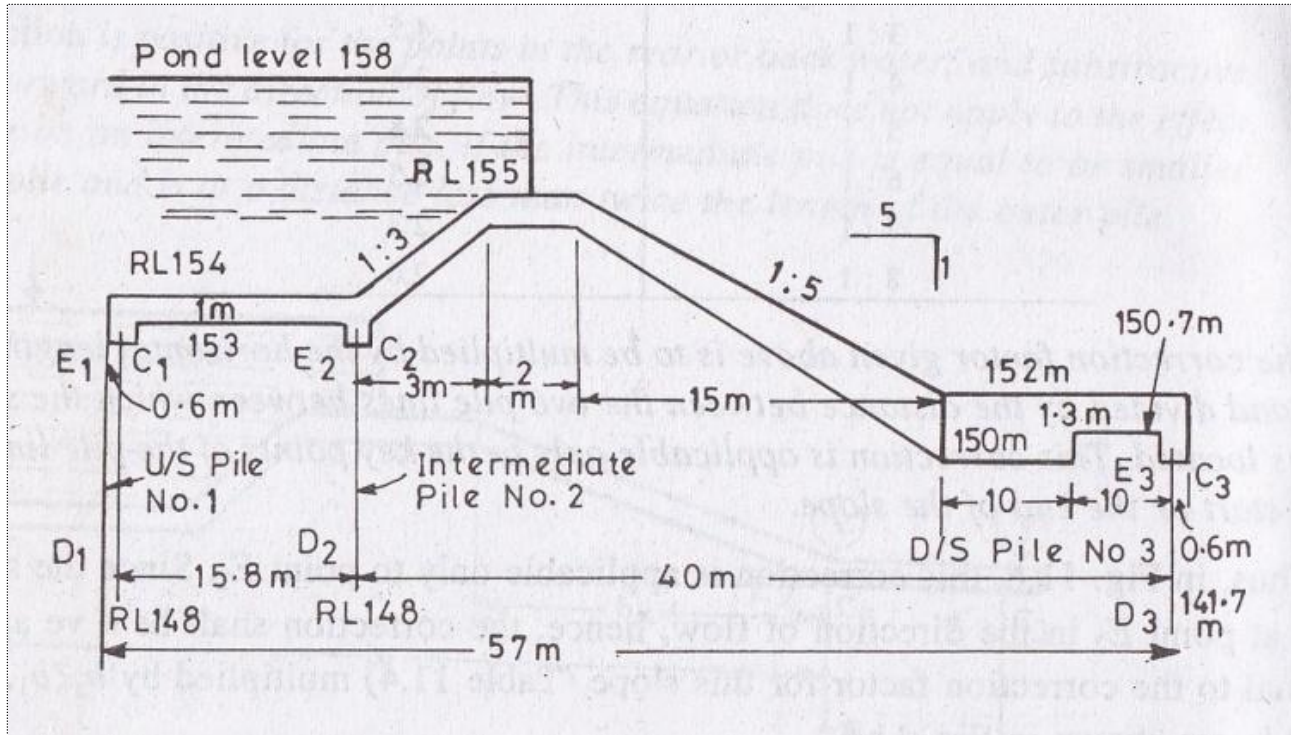

Plate 11.2

Plate 2

Curve 1



Solution:

(1) For upstream Pile No. 1

Total length of the floor, $b = 57.0 \text{ m}$

Depth of u/s pile line, $d = 154 - 148 = 6 \text{ m}$

$$\alpha = b/d = 57/6 = 9.5$$

$$1/\alpha = 1/9.5 = 0.105$$

Plate 1 (a)

0.105

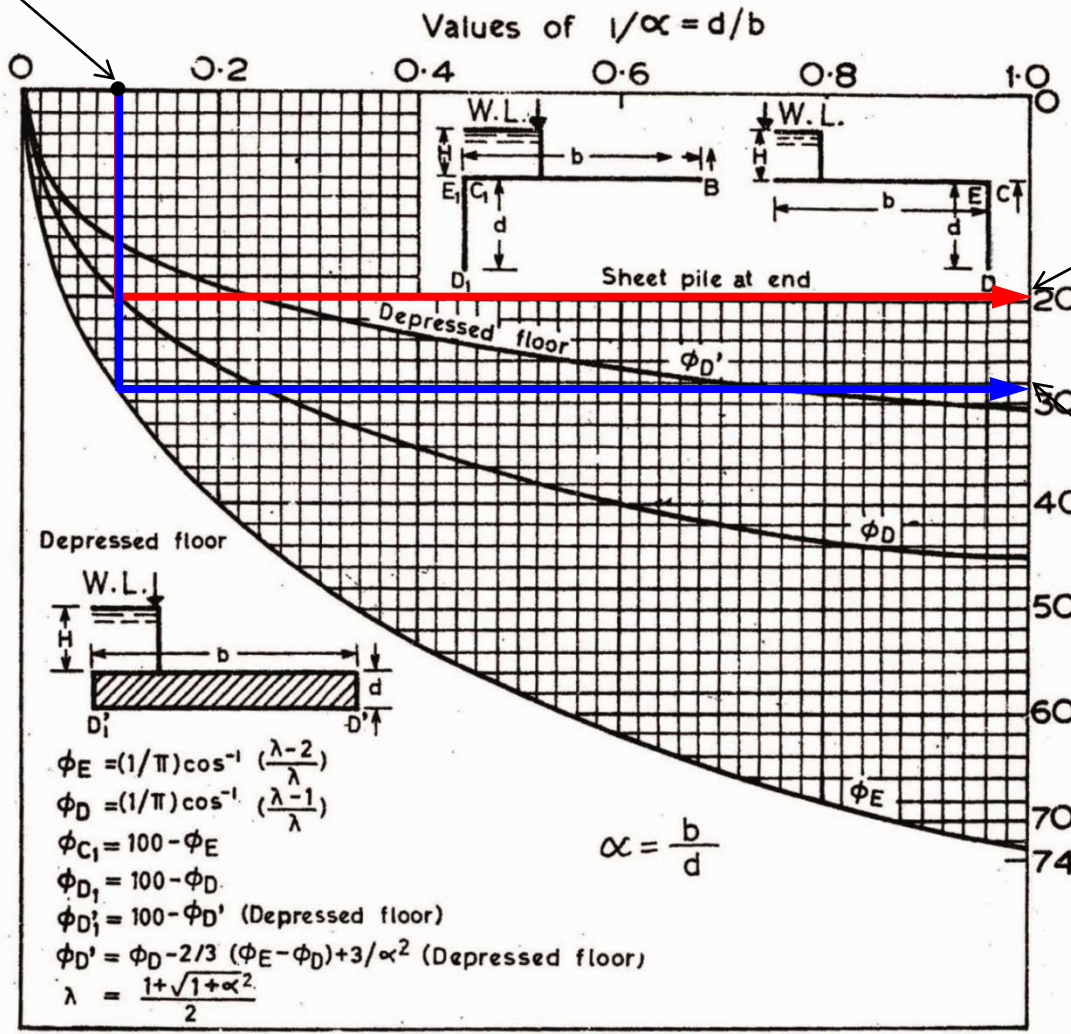

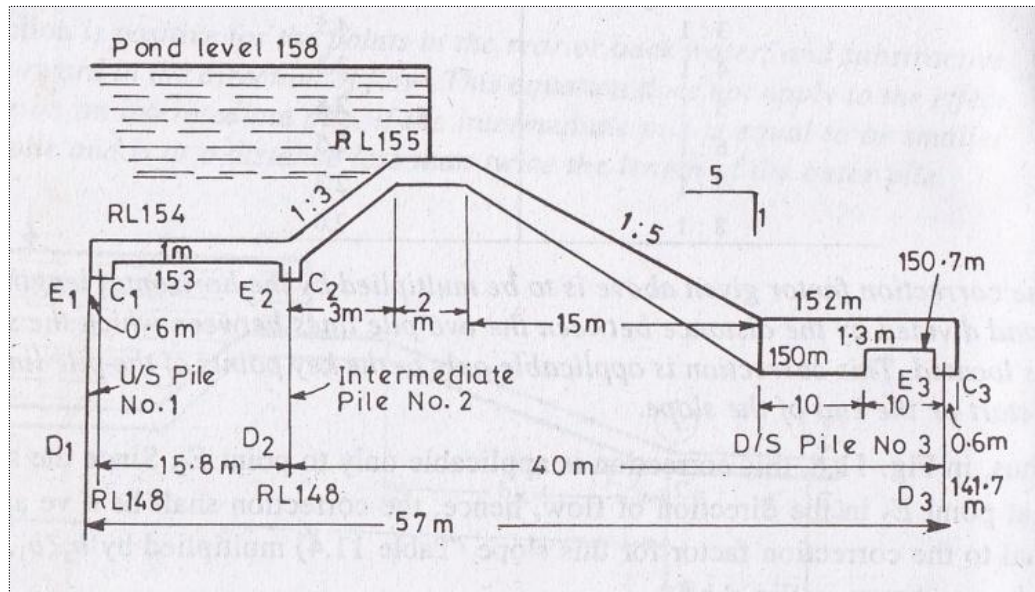

From plate 1 (a)

$$\phi_E = 29 \%$$

$$\phi_D = 20 \%$$

Now,

$$\phi_{C1} = 100 - \phi_E = 100 - 29 = 71 \%$$

$$\phi_{D1} = 100 - \phi_D = 100 - 20 = 80 \%$$

Now

Corrections

At point **C1** only

Corrections for ϕ_{C1}

(a) Mutual Interference of Piles

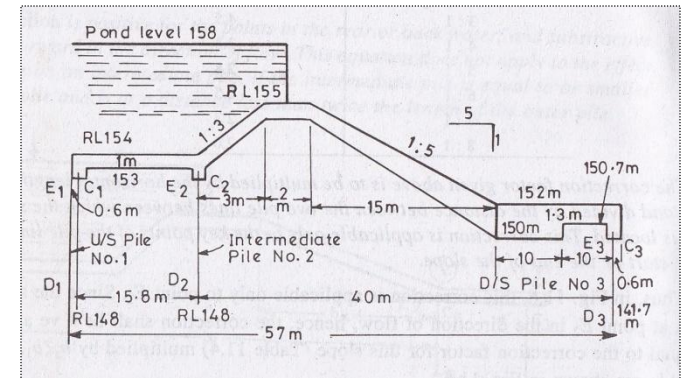

$$C = 19 \sqrt{\frac{D}{b'}} \left(\frac{d + D}{b} \right)$$

$$= 19 \sqrt{\frac{5}{15.8}} \times \left(\frac{5 + 5}{57} \right)$$

$$= 1.88 \%$$

Where, D = Depth of pile No.2

$$= 153 - 148 = 5 \text{ m}$$

d = Depth of pile No. 1 = $153 - 148 = 5 \text{ m}$

b' = Distance between two piles = 15.8 m

b = Total floor length = 57 m

\therefore Correction due to pile interference on $C_1 = 1.88 \%$ (+ ve)

(c) Correction due to slope at C_1 is nil

$$\begin{aligned}\therefore \text{Corrected } (\varphi_{C1}) &= 71 \% + 1.88 \% + 1.5 \% \\ &= 74.38 \%\end{aligned}$$

After Corrections (For Pile No.1)

$$\therefore \varphi_{E1} = 100 \%$$

$$\therefore \varphi_{D1} = 80 \%$$

$$\therefore \varphi_{C1} = 74.38 \%$$

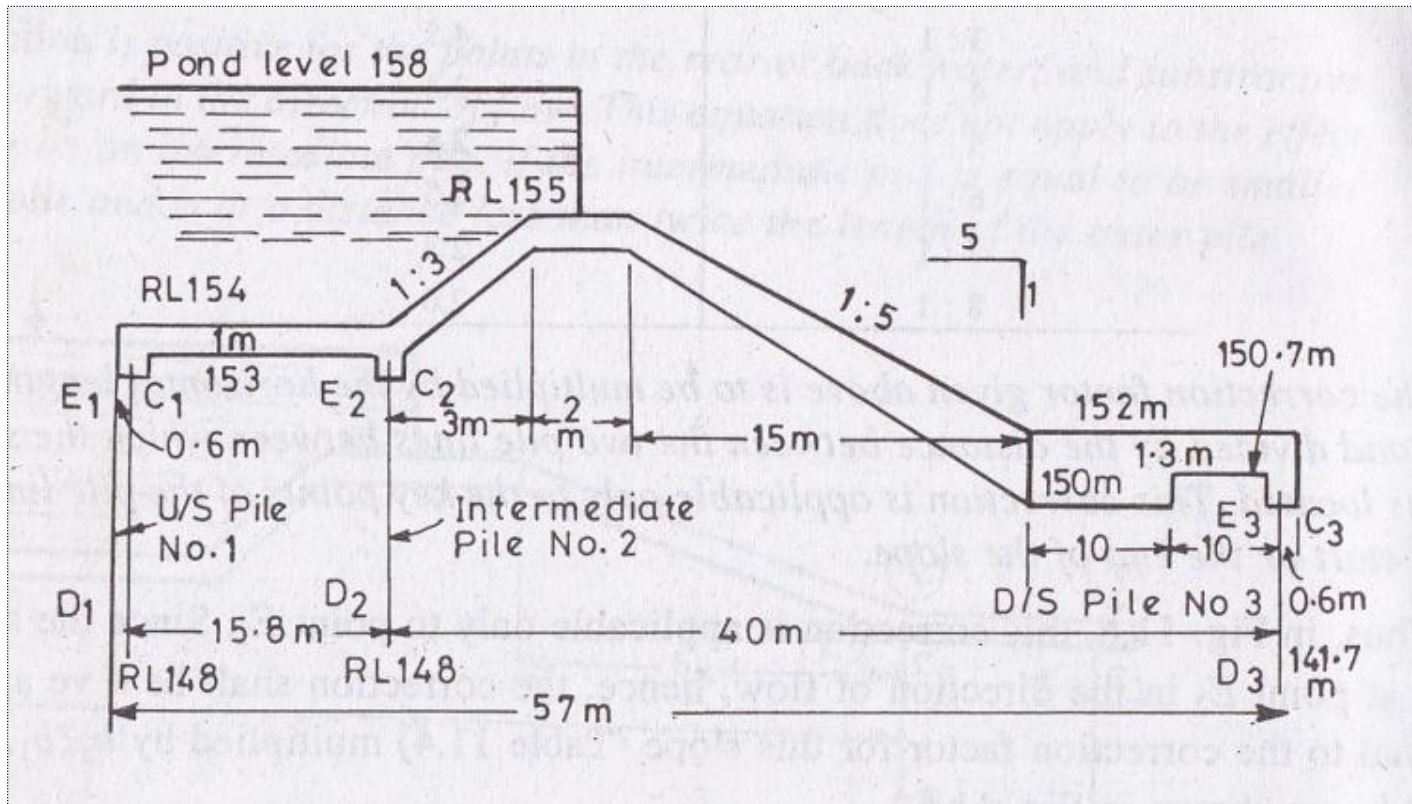

Formula for determining key points pressure at Pile 2:

$$\phi_{E2} = 100 - \phi_C (1 - b_1/b \text{ value} \ \& \ \alpha)$$

$$\phi_{C2} = \text{Direct value from chart } (b_1/b \text{ value} \ \& \ \alpha)$$

$$\phi_{D2} = 100 - \phi_D (1 - b_1/b \text{ value} \ \& \ \alpha)$$

Khosla's Pressure Curves

For a base ratio 0.298 and $\alpha = 9.5$

For a base ratio 0.702 and $\alpha = 9.5$

$\phi_{C2} = 56\%$

$\phi_C = 30\%$

For a base ratio 0.702 and $\alpha = 9.5$

$\phi_D = 37\%$

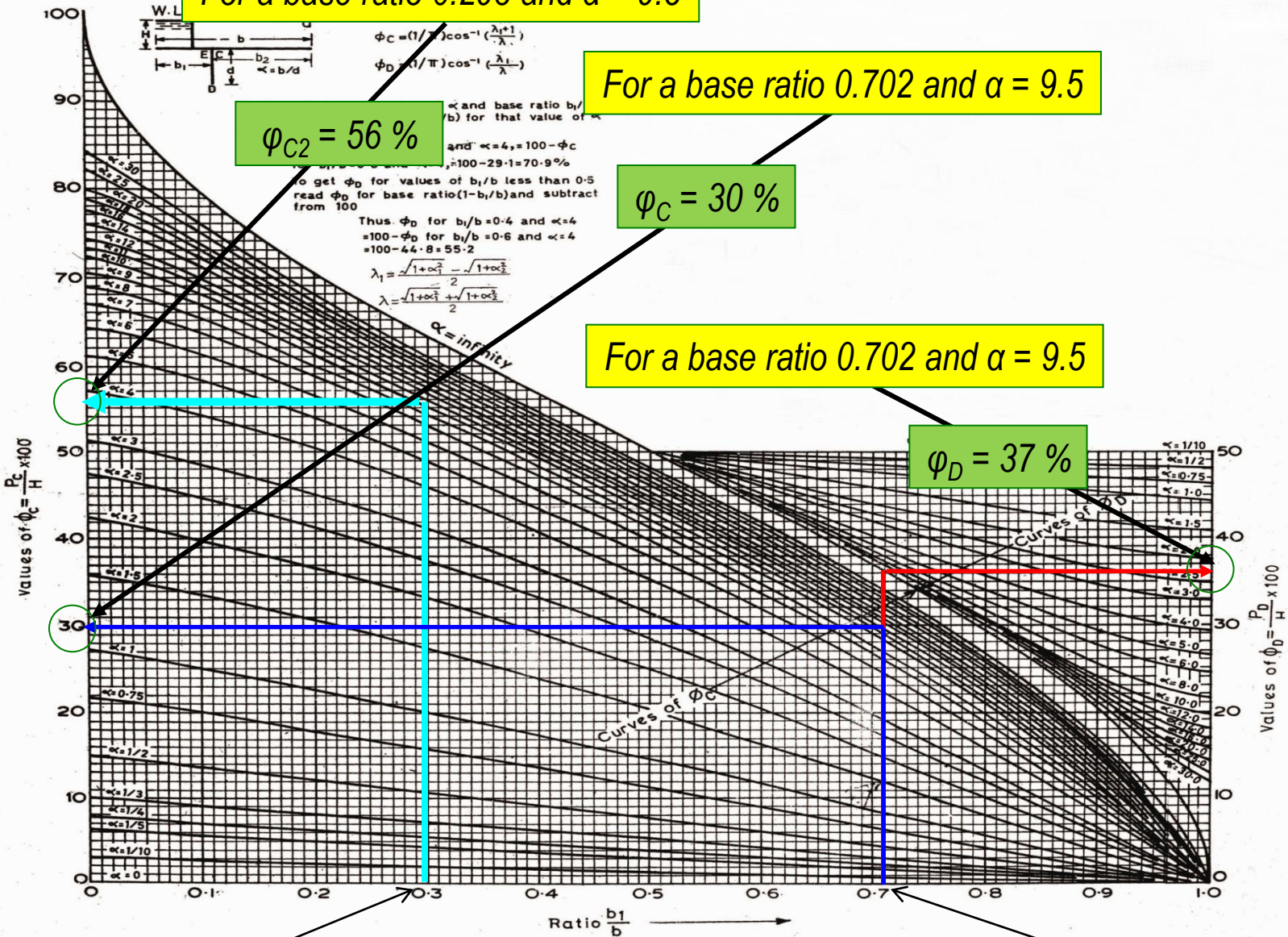

0.298

0.702

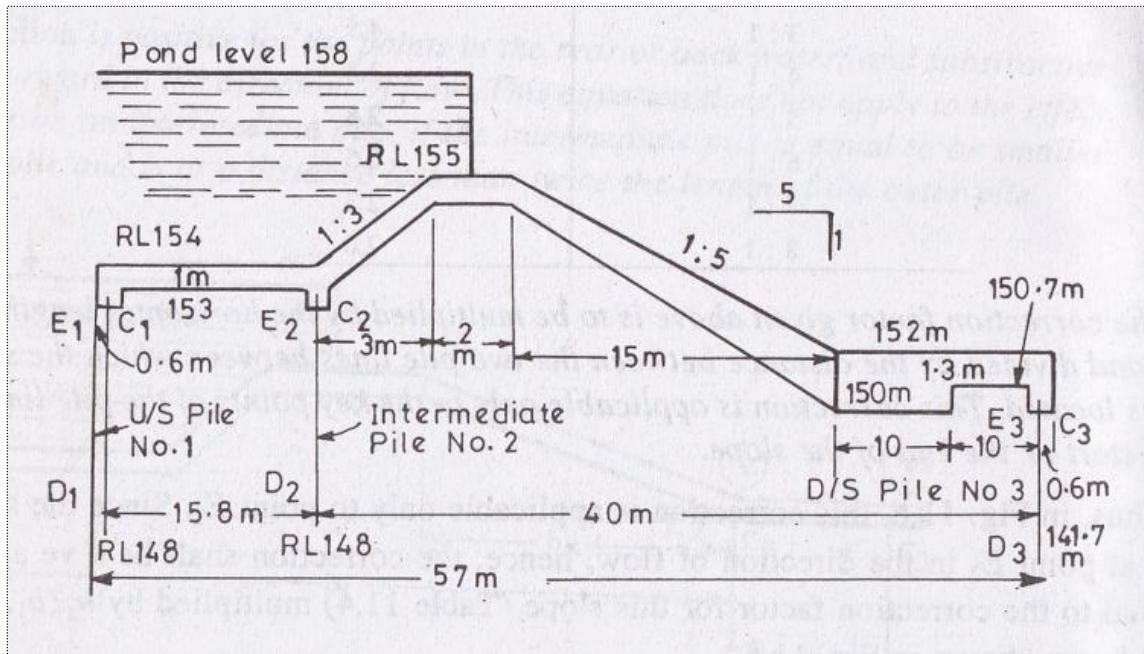

From plate **1 (b)**

$$\varphi_C = 30 \%$$

$$\varphi_D = 37 \%$$

Now,

$$\varphi_{C1} = 100 - \varphi_C = 100 - 30 = 70 \%$$

$$\varphi_{C2} = 56\%$$

$$\varphi_{D1} = 100 - \varphi_D = 100 - 37 = 63 \%$$

Now

Corrections

At points **E2** & **C2**

Corrections for ϕ_{E2}

(a) Mutual Interference of Piles

$$\begin{aligned}
 C &= 19 \sqrt{\frac{D}{b'}} \left(\frac{d + D}{b} \right) \\
 &= 19 \sqrt{\frac{5}{15.7}} \times \left(\frac{5 + 5}{57} \right) \\
 &= 1.88 \% \text{ (-) ve}
 \end{aligned}$$

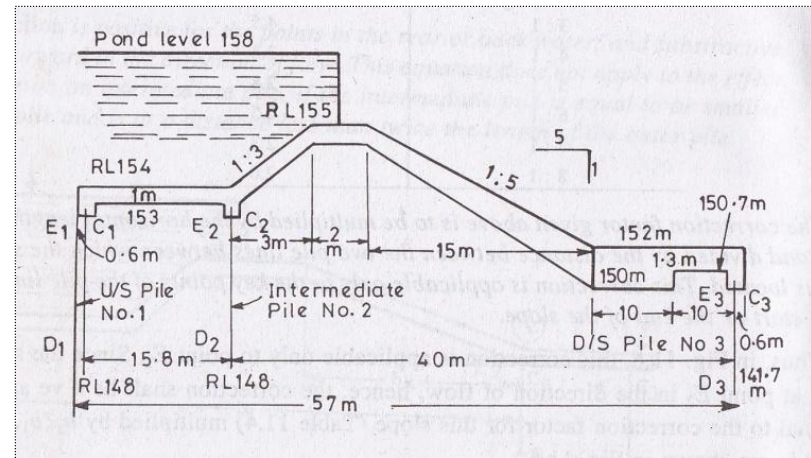

Where, D = Depth of pile No.1, the effect of which is considered

$$= 153 - 148 = 5 \text{ m}$$

d = Depth of pile No. 2, the effect on which is considered

$$= 153 - 148 = 5 \text{ m}$$

b' = Distance between two piles

$$= 15.8 \text{ m}$$

b = Total floor length = 57 m

(b) Thickness correction (φ_{E_2})

$$= \frac{\text{Obs } \varphi_{E_2} - \text{Obs } \varphi_{D_2}}{\text{Distance between } E_2 D_2} \text{ Thickness of floor}$$

$$= \left[\frac{70\% - 63\%}{154 - 148} \right] 1.0 = (7/6) 1.0 = 1.17 \%$$

This correction is negative,

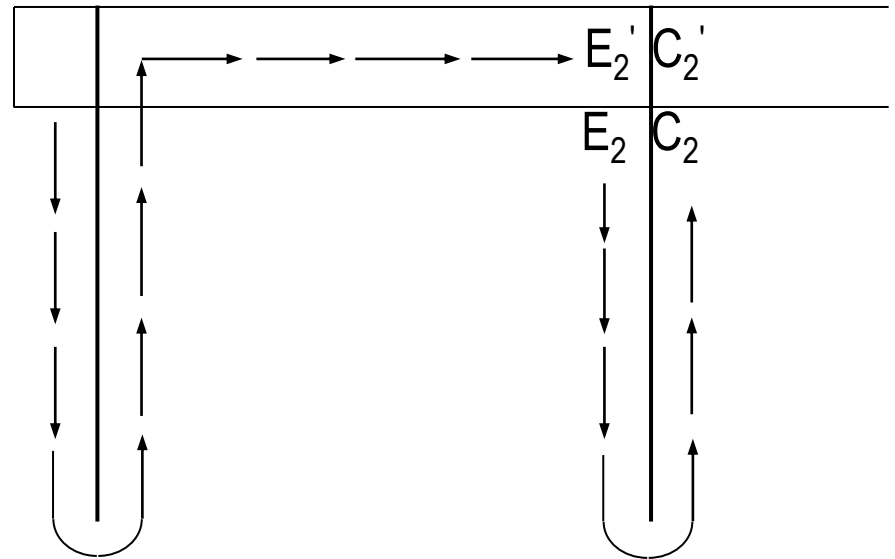

Fig: 5.2

(c) Correction due to slope

Slope correction at E_2 due to slope is nil

Hence, corrected percentage pressure at E_2

$$= \text{Corrected } \phi_{E_2}$$

$$= (70 - 1.88 - 1.17) \% = 66.95 \%$$

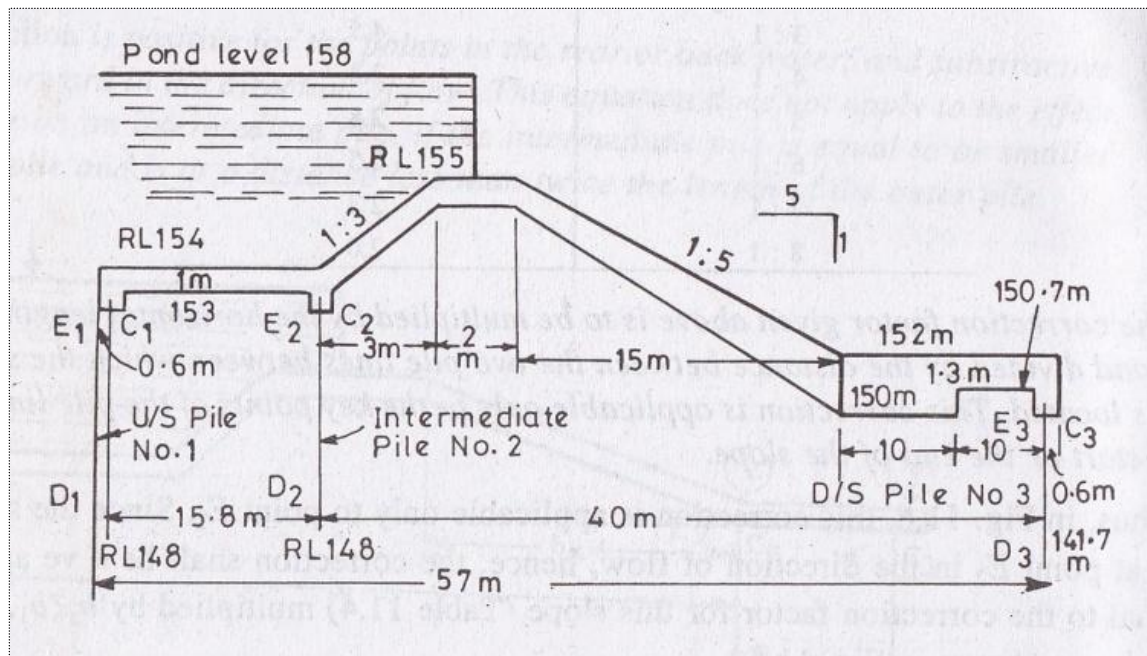

Corrections for ϕ_{C2}

(a) Mutual Interference of Piles

$$\begin{aligned}
 C &= 19 \sqrt{\frac{D}{b'} \left(\frac{d + D}{b} \right)} \\
 &= 19 \sqrt{\frac{11}{40} \times \left(\frac{11 + 5}{57} \right)} \\
 &= 2.89 \% (+) \text{ve}
 \end{aligned}$$

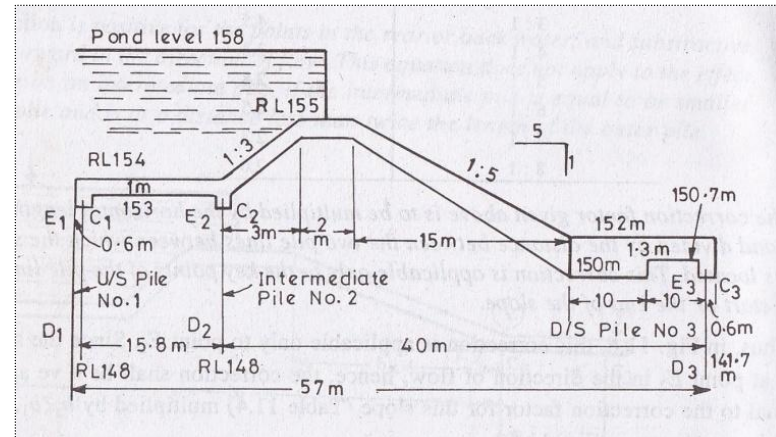

Where, D = Depth of pile No.3, the effect of which is considered

$$= 153 - 141.7 = 11.3 \text{ m}$$

d = Depth of pile No. 2, the effect on which is considered

$$= 153 - 148 = 5 \text{ m}$$

b' = Distance between two piles (2 &3)

$$= 40 \text{ m}$$

b = Total floor length = 57 m

(c) Correction at C_2 due to slope.

Correction factor for 3:1 slope from Table 5.3 = 4.5

Horizontal length of the slope = 3 m

Distance between two pile lines between which the sloping floor is located = 40 m

$$\therefore \text{Actual correction} = 4.5 \left(\frac{3}{40} \right) = 0.34 \% \text{ (- ve)}$$

$$\begin{aligned} \text{Hence, corrected } \phi_{C_2} &= (56 + 2.89 + 1.17 - 0.34) \% \\ &= 59.72 \% \end{aligned}$$

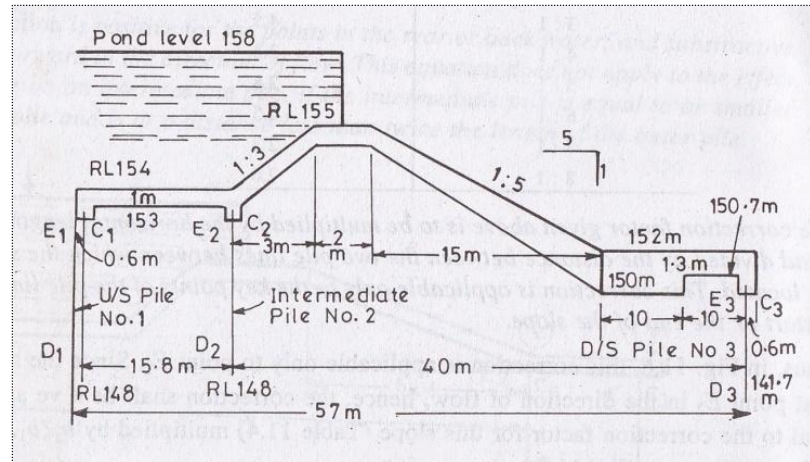

After Corrections (For Pile No.2)

$$\therefore \phi_{E2} = 66.95 \%$$

$$\therefore \phi_{D2} = 56 \%$$

$$\therefore \phi_{C2} = 59.72 \%$$

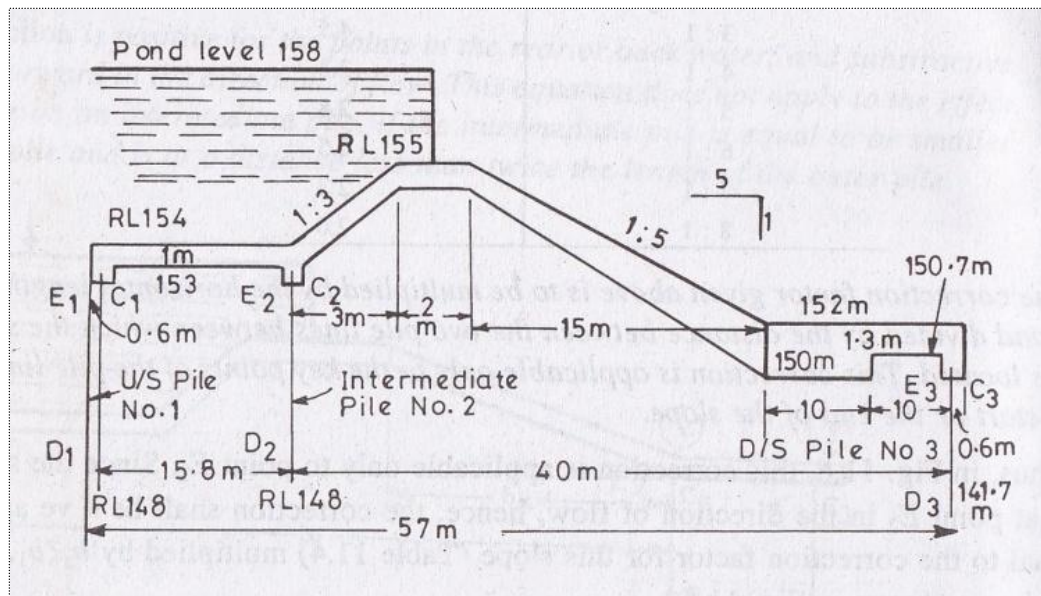

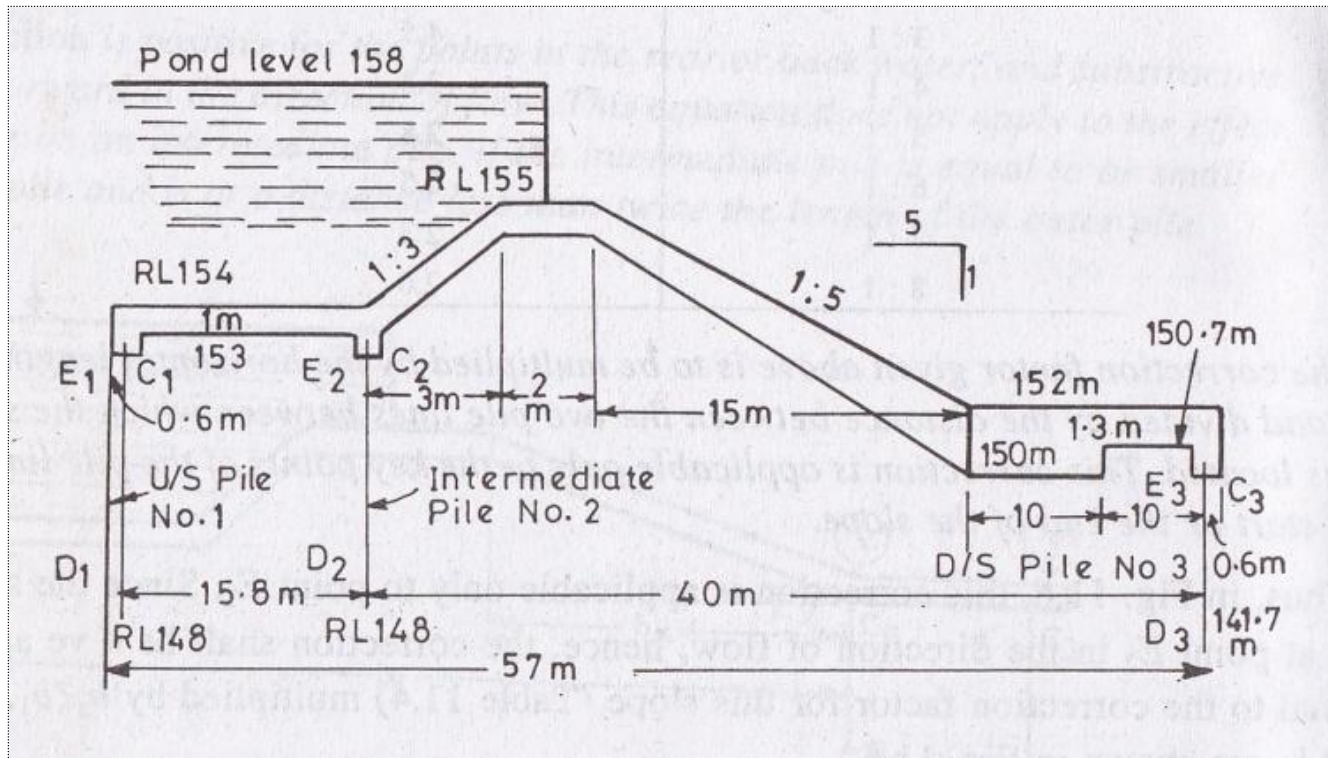

(3) For upstream Pile Line No. 3

$$b = 57 \text{ m}$$

$$d = 152 - 141.7 = 10.3 \text{ m}$$

$$1/\alpha = d/b = 10.3/57 = 0.181$$

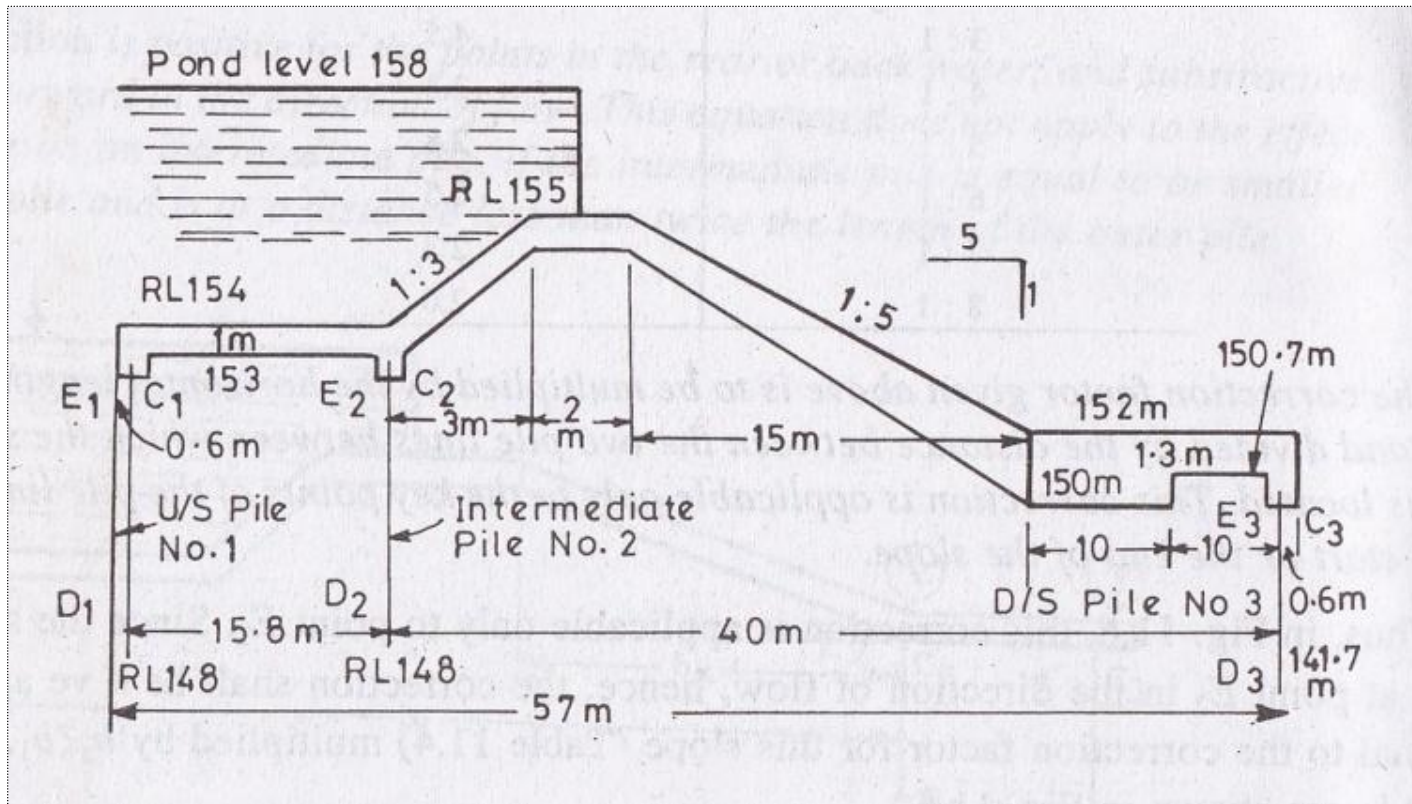

Formula for determining key points pressure at Pile 3:

ϕ_{E3} = Direct value from chart ($1/\alpha$ value)

ϕ_{C3} = 0

ϕ_{D3} = Direct value from chart ($1/\alpha$ value)

Plate 1 (a)

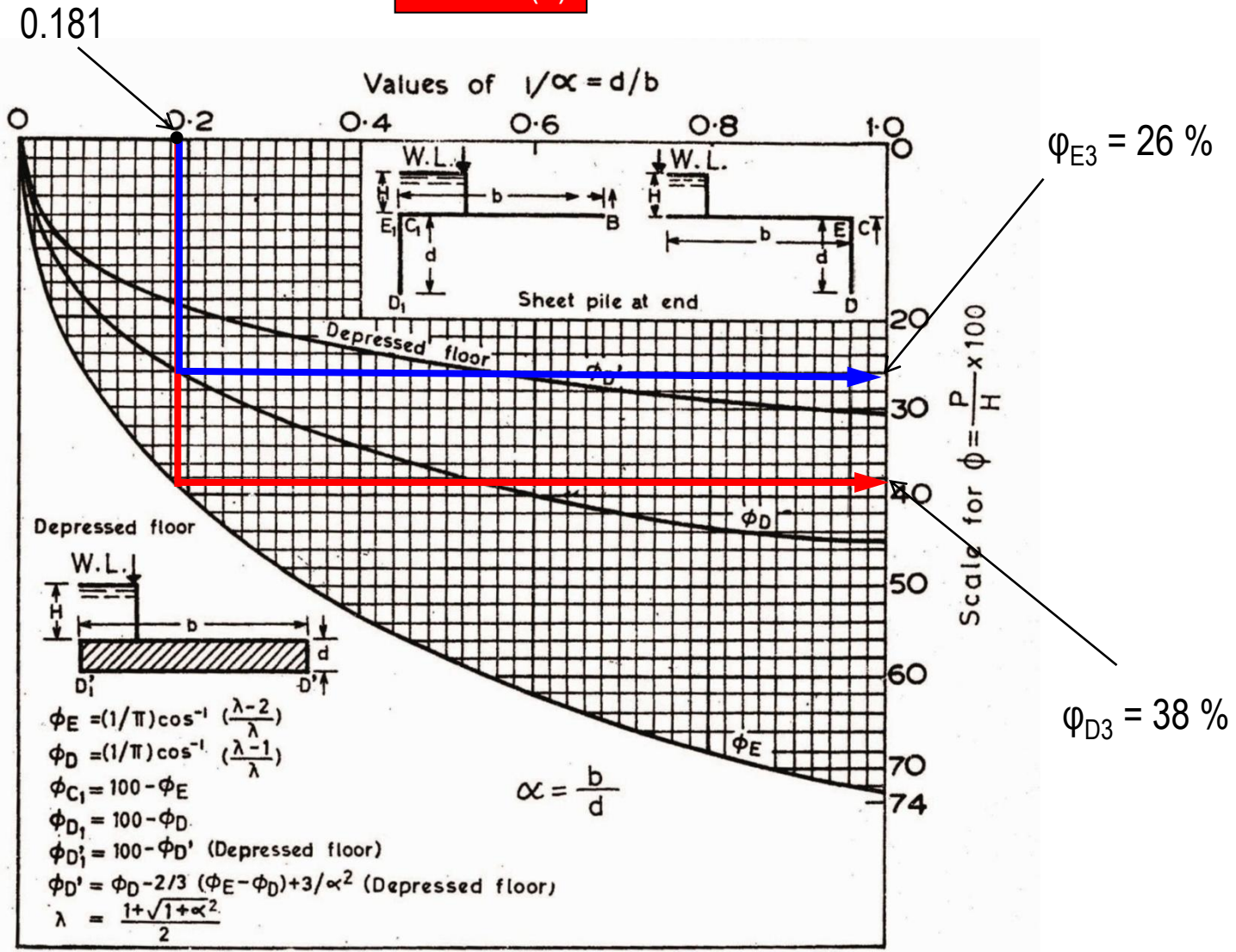

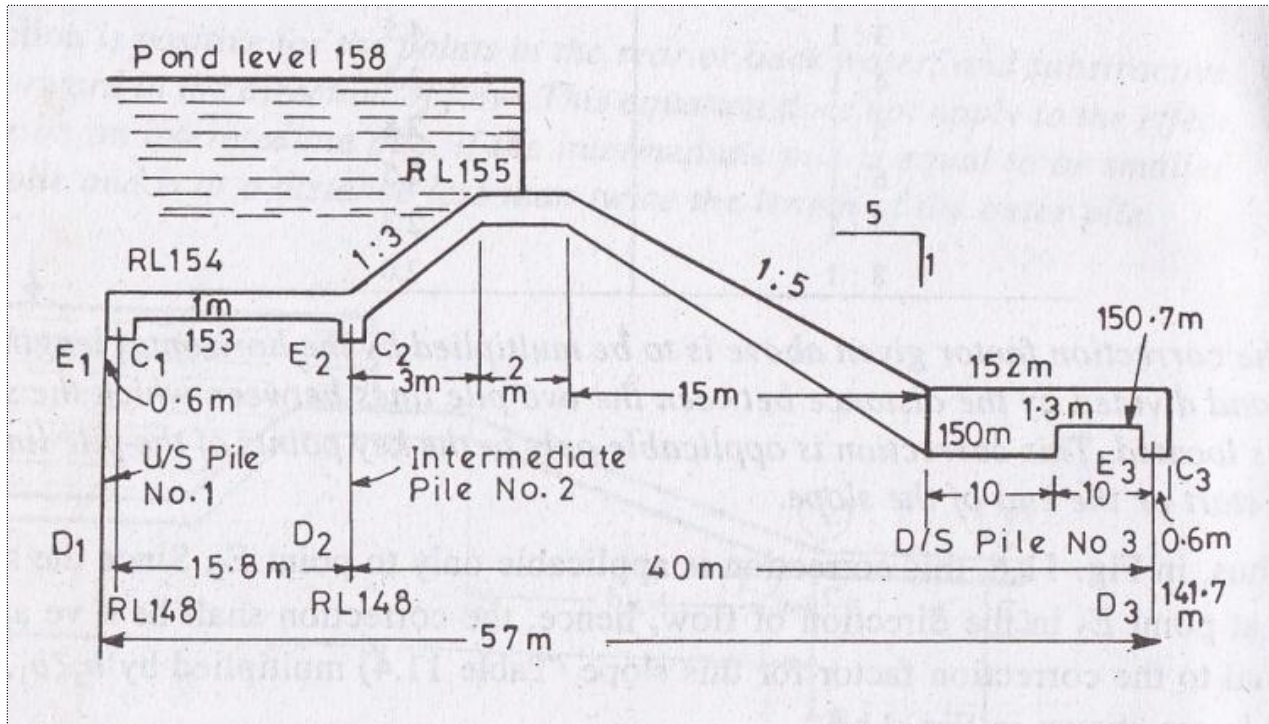

From plate 1 (a)

$$\varphi_{E3} = 38 \%$$

$$\varphi_{D3} = 26\%$$

Now

Corrections

At point **E3** only

Corrections for ϕ_{E3}

(a) Mutual Interference of Piles

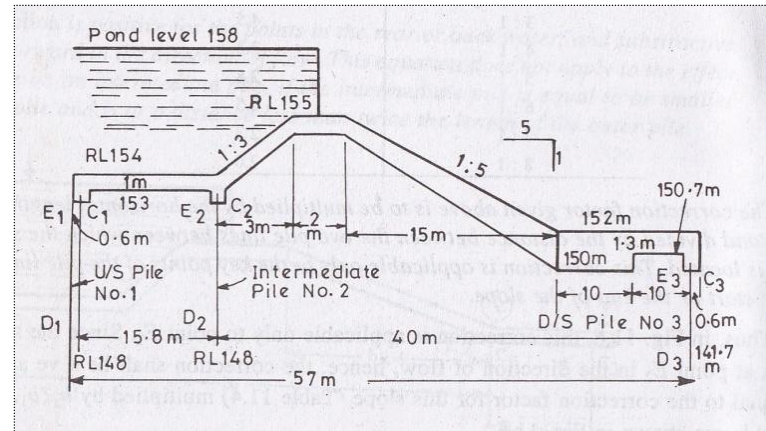

$$\begin{aligned}
 C &= 19 \sqrt{\frac{D}{b'}} \left(\frac{d+D}{b} \right) \\
 &= 19 \sqrt{\frac{2.7}{40}} \times \left(\frac{9+2.7}{57} \right) \\
 &= 1.02 \% \text{ (-) ve}
 \end{aligned}$$

Where,

D = Depth of pile No.2, the effect of which is considered = $150.7 - 148 = 2.7$ m

d = Depth of pile No. 3, the effect on which is considered = $150 - 141.7 = 9$ m

b' = Distance between two piles = 40 m

b = Total floor length = 57 m

(b) Correction due to floor thickness:

$$\begin{aligned} &= \left[\frac{38\% - 32\%}{152 - 141.7} \right] 1.3 \\ &= \left[\frac{16}{10.3} \right] 1.3 \\ &= 0.76 \% (-ve) \end{aligned}$$

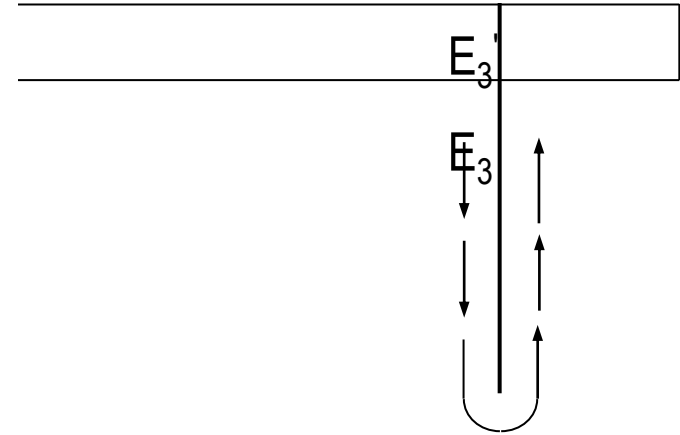

Fig: 7.3

(c) Correction due to slope at E_3 is nil,

Hence, corrected $\varphi_{E_3} = (38 - 1.02 - 0.76) \% = 36.22 \%$

After Corrections (For Pile No.3)

$$\therefore \phi_{E3} = 36.22 \%$$

$$\therefore \phi_{D3} = 26 \%$$

$$\therefore \phi_{C3} = 0 \%$$

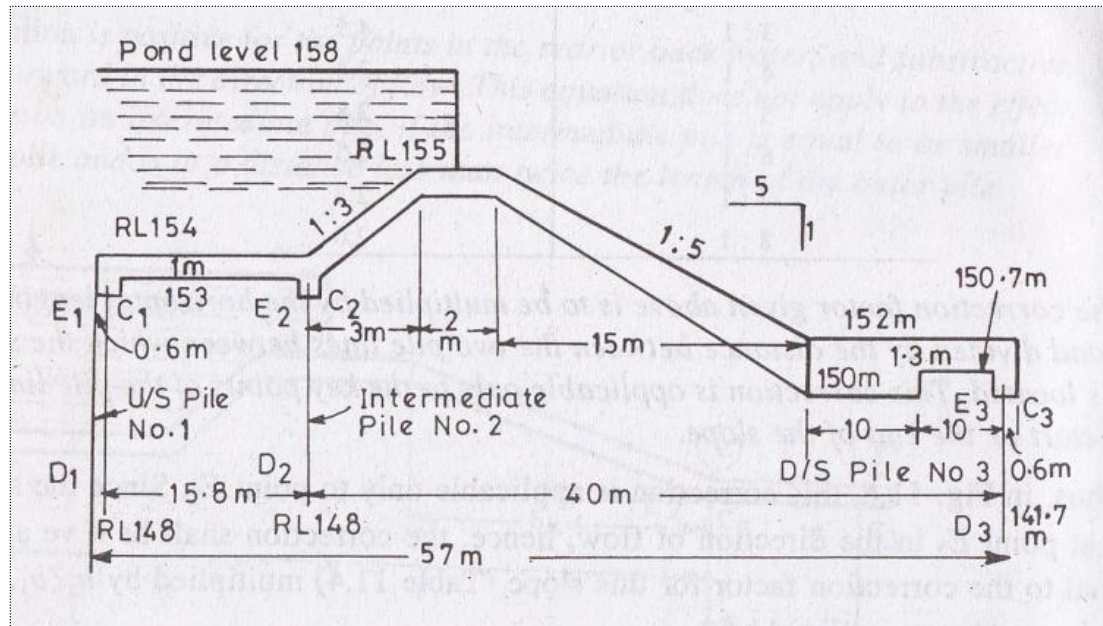

The corrected pressures at various key points are tabulated below in Table below

Upstream Pile No. 1	Intermediate Pile No.2	Downstream Pile No. 3
$\varphi_{E1} = 100 \%$	$\varphi_{E2} = 66.95 \%$	$\varphi_{E3} = 36.22 \%$
$\varphi_{D1} = 80 \%$	$\varphi_{D2} = 63 \%$	$\varphi_{D3} = 26 \%$
$\varphi_{C1} = 74.38 \%$	$\varphi_{C2} = 59.72 \%$	$\varphi_{C3} = 0 \%$

Exit gradient

The maximum seepage head, $H = 158 - 152 = 6 \text{ m}$

The depth of downstream cur-off, $d = 152 - 141.7 = 10.3 \text{ m}$

Total floor length, $b = 57 \text{ m}$

$$\alpha = b/d = 57/10.3 = 5.53$$

For a value of $\alpha = 5.53$, $\frac{1}{\pi\sqrt{\lambda}}$ from curves of Plate 2 is equal to 0.18

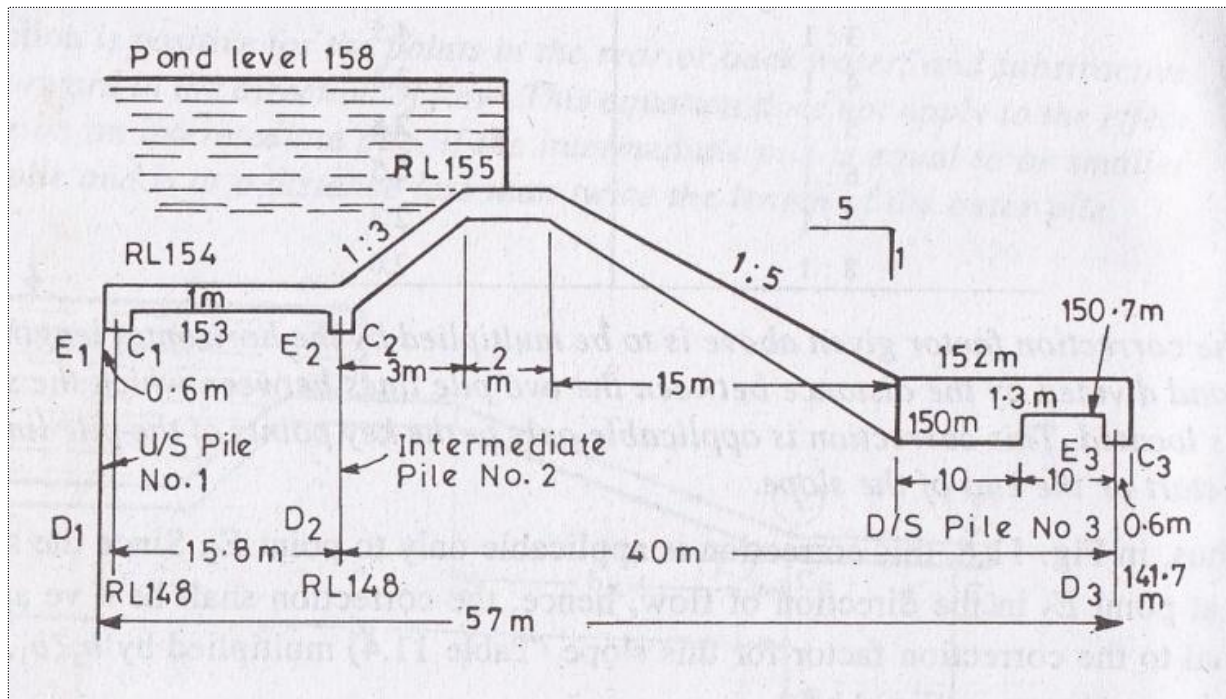

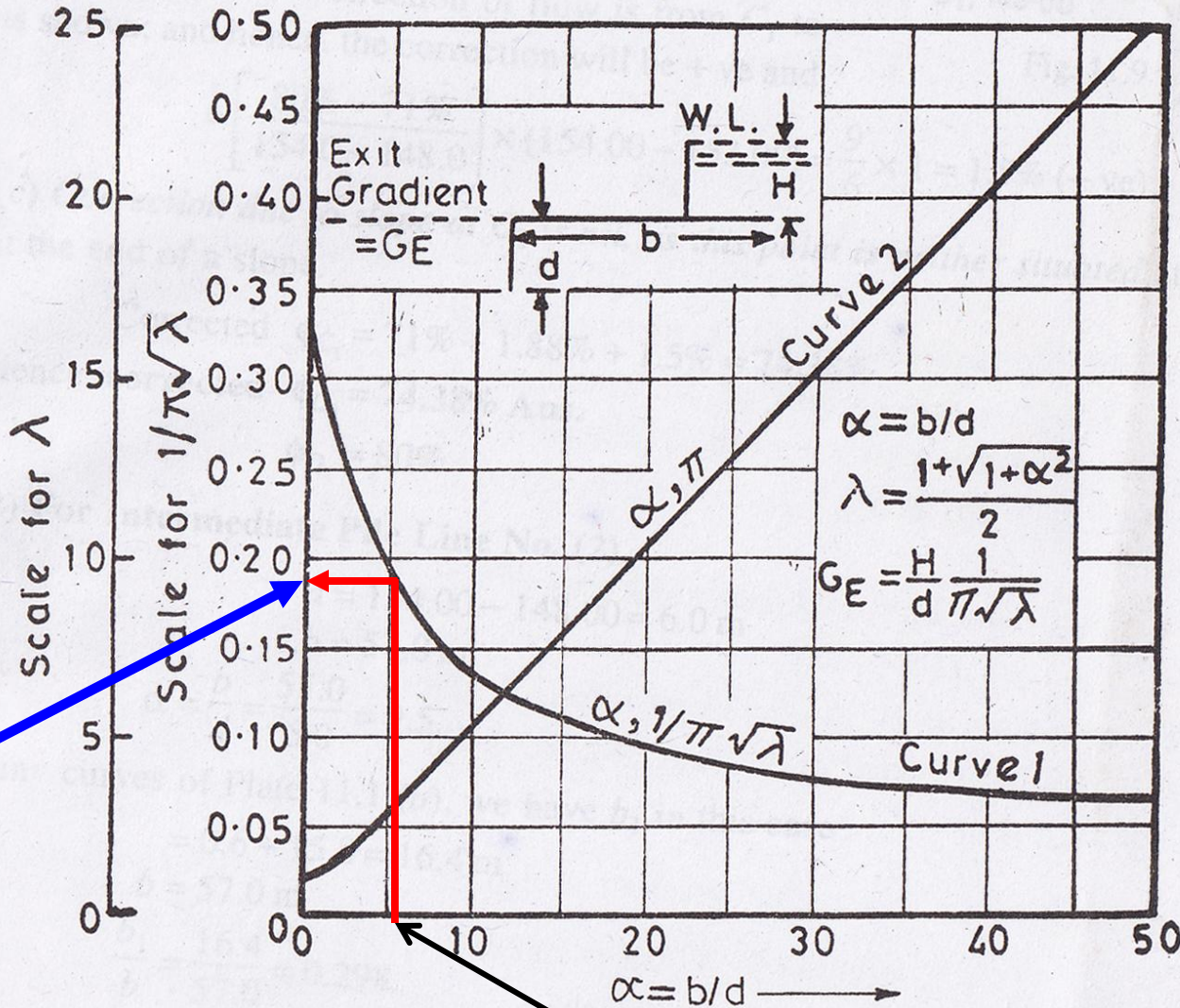

$$\frac{1}{\pi\sqrt{\lambda}} = 0.18$$

$$G_E = \frac{H}{d} \times \frac{1}{\pi\sqrt{\lambda}} = \frac{6}{10.3} \quad 0.18 = 0.105$$

Hence, the exit gradient shall be equal to 0.105, *i.e.* 1 in 9.53, which is very much safe.

Type of Soil	Safe exit gradient
Shingle	1/4 to 1/5 (0.25 to 0.20)
Coarse Sand	1/5 to 1/6 (0.20 to 0.17)
Fine Sand	1/6 to 1/7 (0.17 to 0.14)

End of Chapter – 5