

CHAPTER – 9

Irrigation Structures – 2

Dr. M. R. Kabir

Professor and Head, Department of Civil Engineering

University of Asia Pacific (UAP), Dhaka

LECTURE 22



What is Cross Drainage Works?

In an irrigation project, when the network of main canals, branch canals, distributaries, etc. are provided, then these canals may have to cross the natural drainages like rivers, streams, nallahs, etc at different points within the command area of the project. The crossing of the canals with such obstacle cannot be avoided. So, suitable structures must be constructed at the crossing point for the easy flow of water of the canal and drainage in the respective directions. These structures are known as ***cross-drainage works***.

Navigation Lock





Necessity of Cross Drainage Works

- ❑ The water-shed canals do not cross natural drainages. But in actual orientation of the canal network, this ideal condition may not be available and the obstacles like natural drainages may be present across the canal. So, the cross drainage works must be provided for running the irrigation system.
- ❑ At the crossing point, the water of the canal and the drainage get intermixed. So, for the smooth running of the canal with its design discharge the cross drainage works are required.
- ❑ The site condition of the crossing point may be such that without any suitable structure, the water of the canal and drainage can not be diverted to their natural directions. So, the cross drainage works must be provided to maintain their natural direction of flow.

Types of Cross Drainage Works

- ❑ **Type I (Irrigation canal passes over the drainage)**
 - (a) Aqueduct
 - (b) Siphon Aqueduct

- ❑ **Type II (Drainage passes over the irrigation canal)**
 - (a) Super passage
 - (b) Siphon super passage

- ❑ **Type III (Drainage and canal intersection each other of the same level)**
 - (a) Level crossing
 - (b) Inlet and outlet

Selection of Type of Cross Drainage Works

- ✓ Relative bed levels
- ✓ Availability of suitable foundation
- ✓ Economical consideration
- ✓ Discharge of the drainage
- ✓ Construction problems

Aqueduct

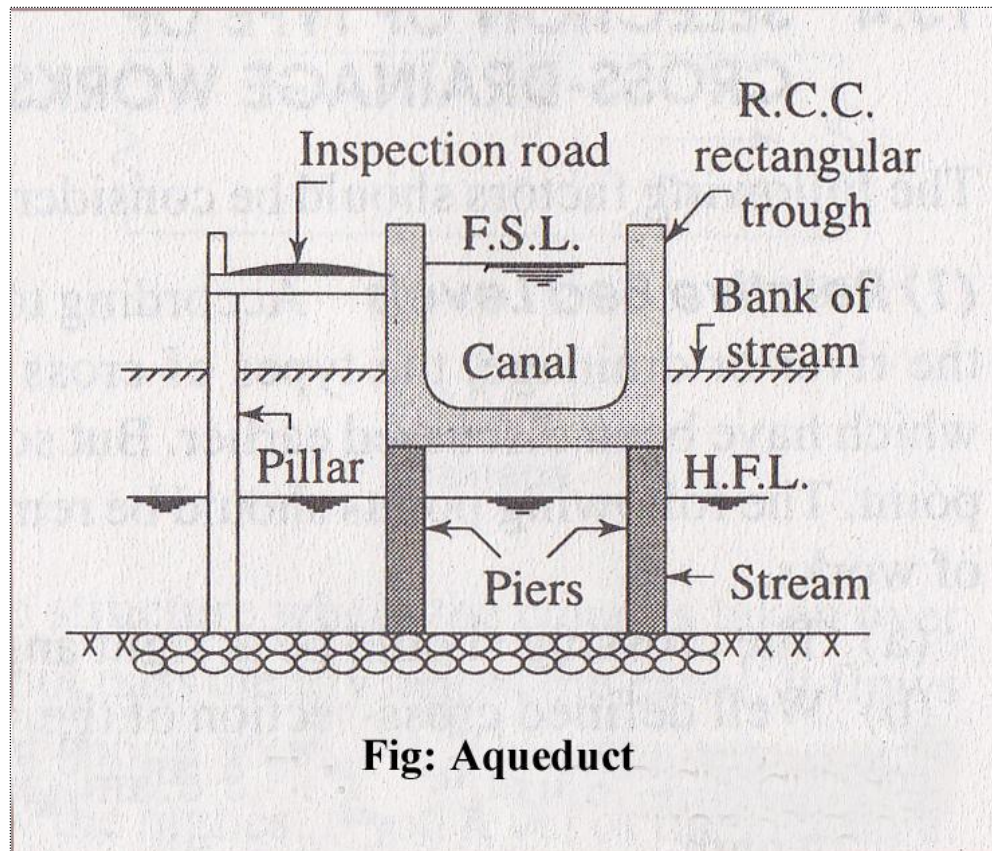

Cont..... Aqueduct



Cont..... Aqueduct



Siphon Aqueduct

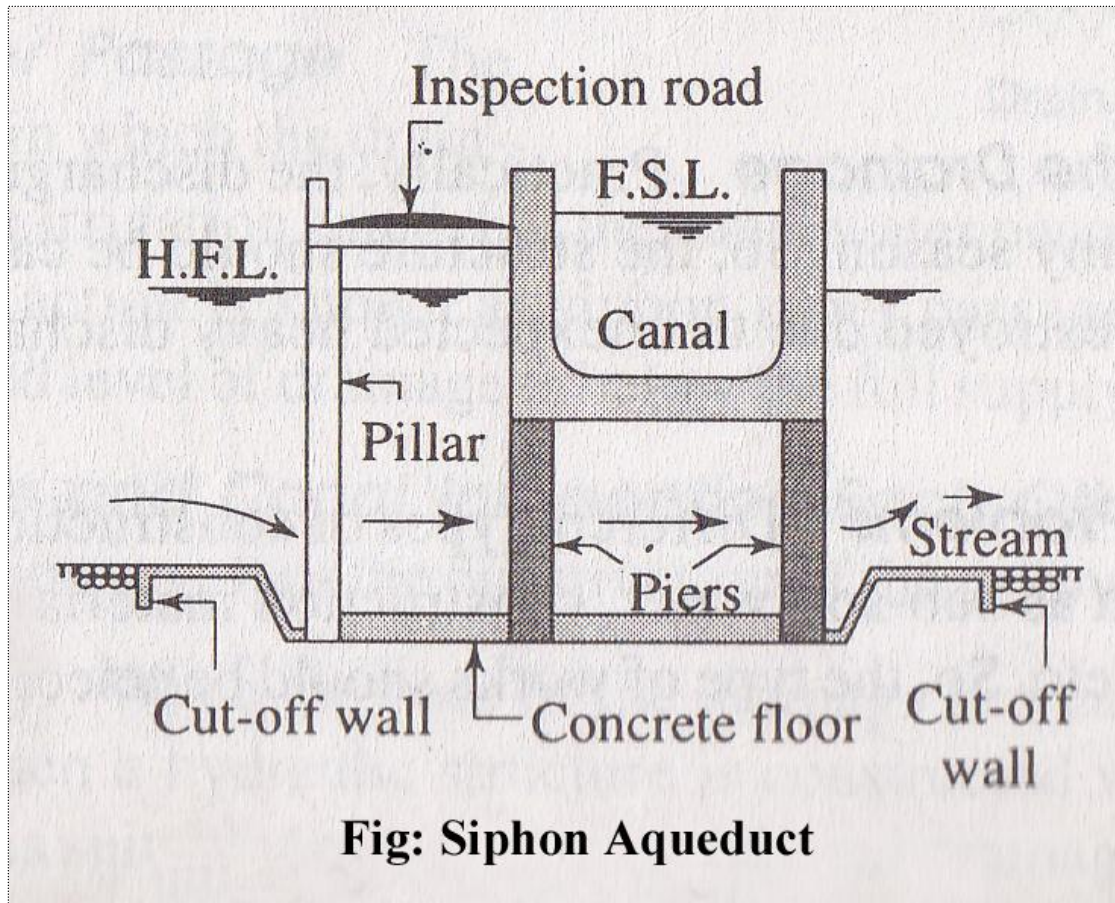

Super Passage

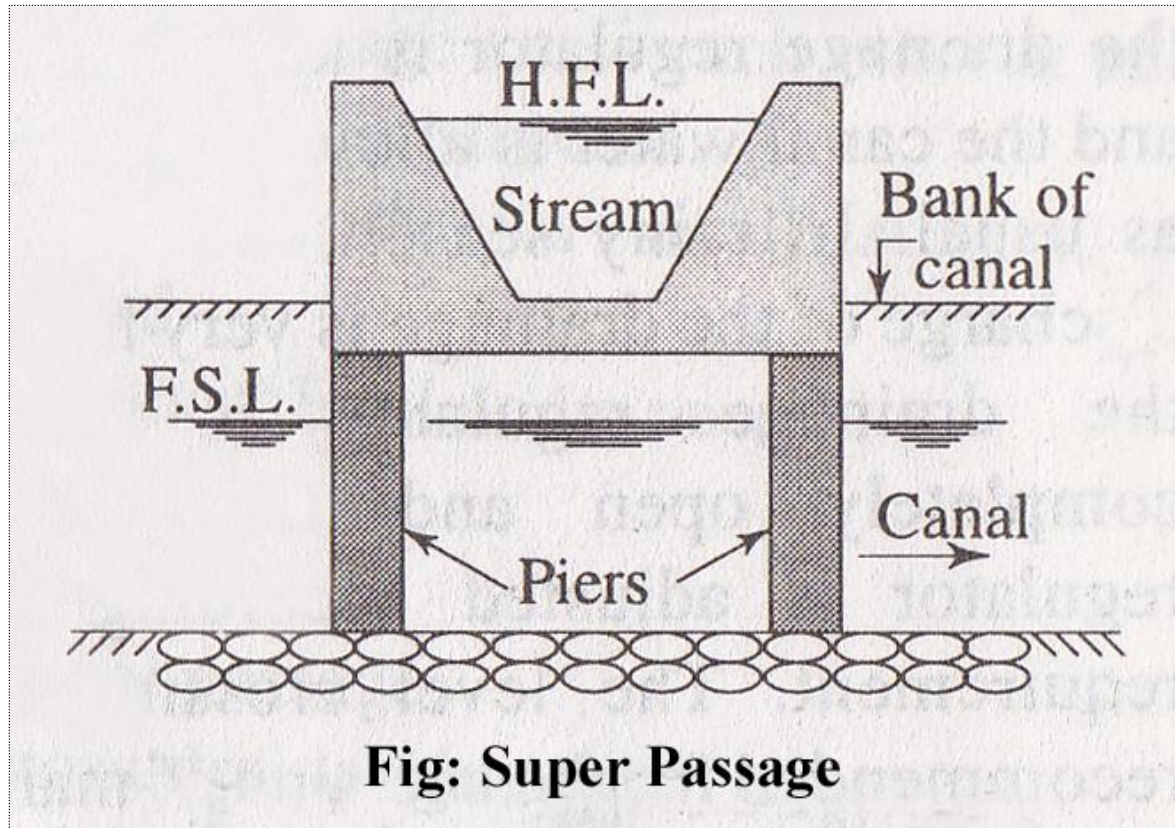

Siphon Super Passage

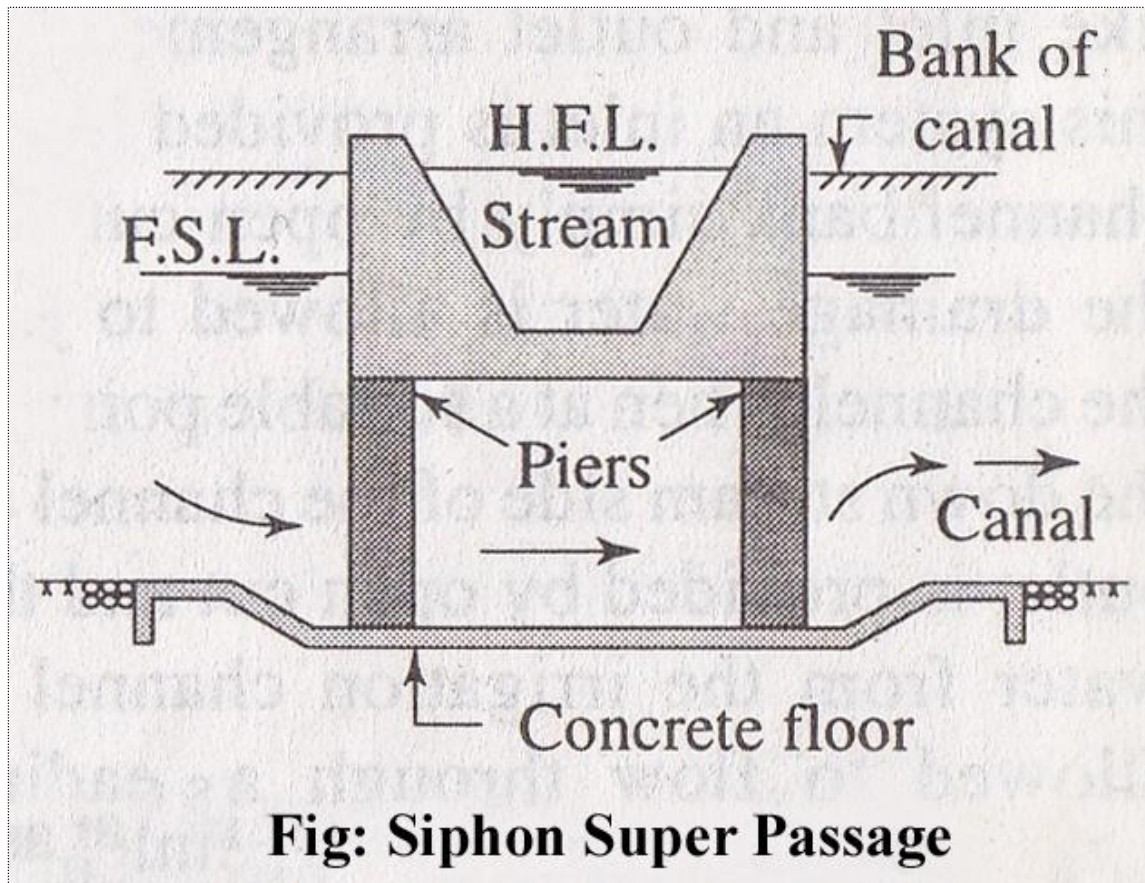

Level Crossing

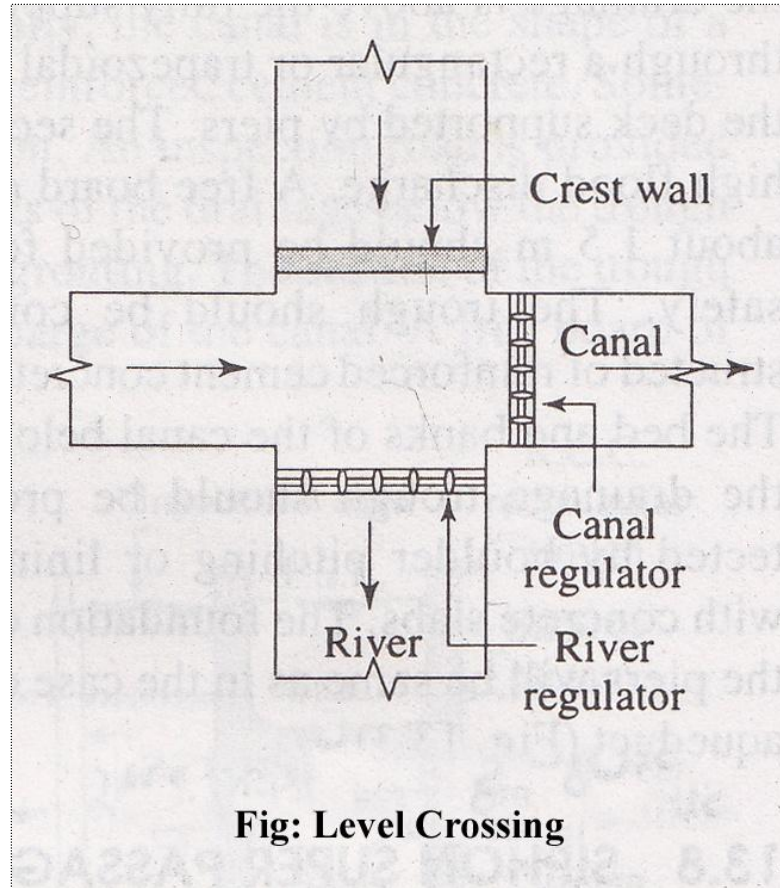

Inlet and Outlet

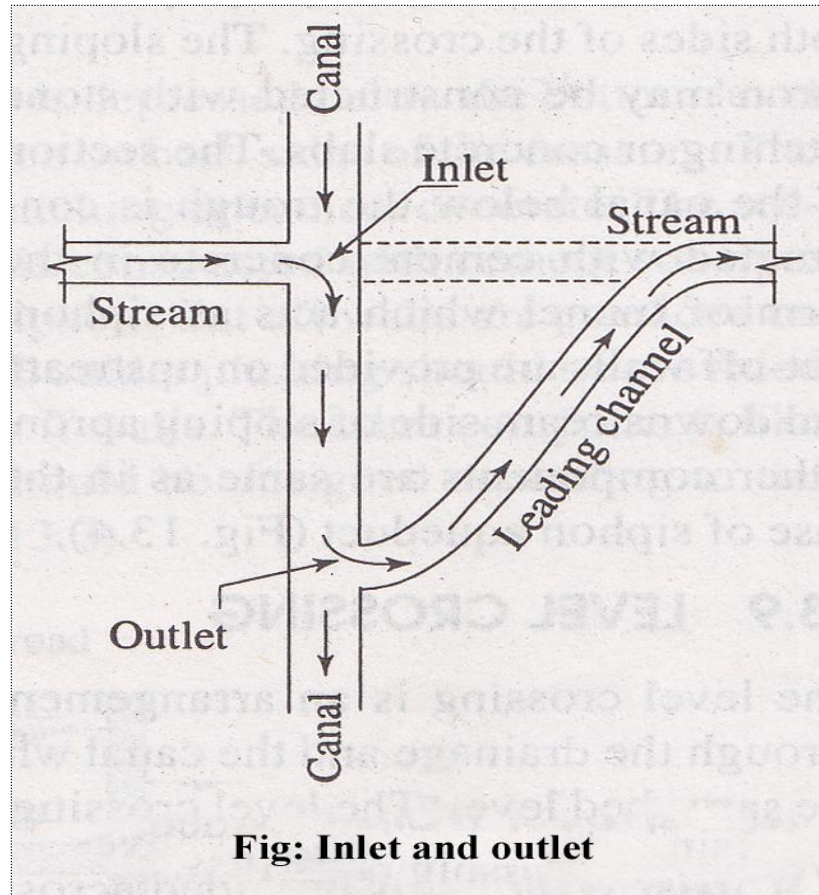

Fig: Inlet and outlet

LECTURE 23



What is Canal Fall?

Whenever the available natural ground slope is steep than the designed bed slope of the channel, the difference is adjusted by constructing vertical 'falls' or 'drops' in the canal bed at suitable intervals, as shown in figure below.

Such a drop in a natural canal bed will not be stable and, therefore, in order to retain this drop, a masonry structure is constructed. Such a pucca structure is called a Canal Fall or a Canal drop.

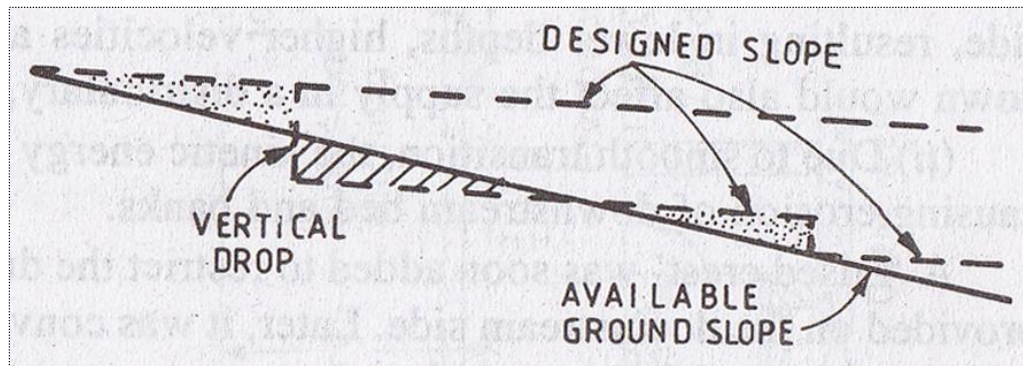

Necessity of Canal Falls

- When the slope of the ground suddenly changes to steeper slope, the permissible bed slope can not be maintained. It requires excessive earthwork in filling to maintain the slope. In such a case falls are provided to avoid excessive earth work in filling (**Fig. 1**)

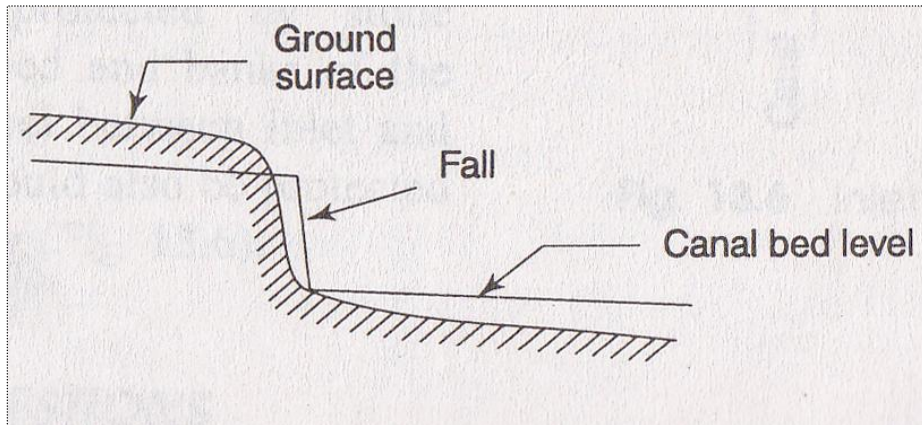

Fig. 1

- When the slope of the ground is more or less uniform and the slope is greater than the permissible bed slope of canal. (Fig.2)

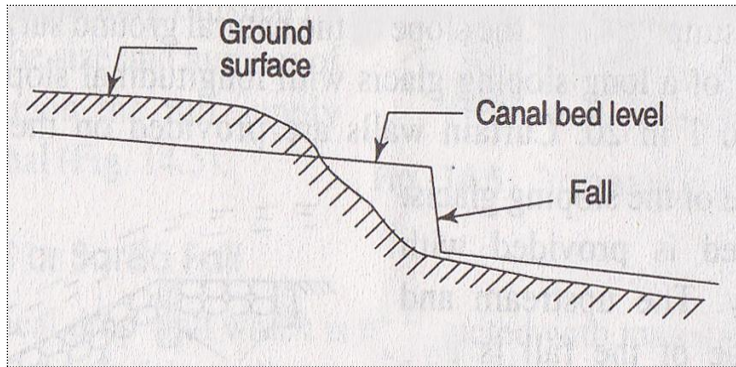

Fig. 2

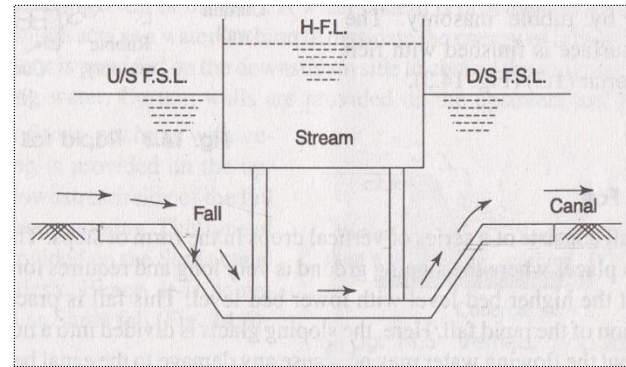

Fig. 3

- In cross-drainage works, when the difference between bed level of canal and that of drainage is small or when the F.S.L of the canal is above the bed level of drainage then the canal fall is necessary to carry the canal water below the stream or drainage. (Fig. 3)

Types of Canal Falls

- Ogee Fall
- Rapid Fall
- Stepped Fall
- Trapezoidal Notch Fall
- Vertical Drop Fall
- Glacis Fall
 - (a) Montague Type Fall
 - (b) Inglis Type Fall

Ogee Fall

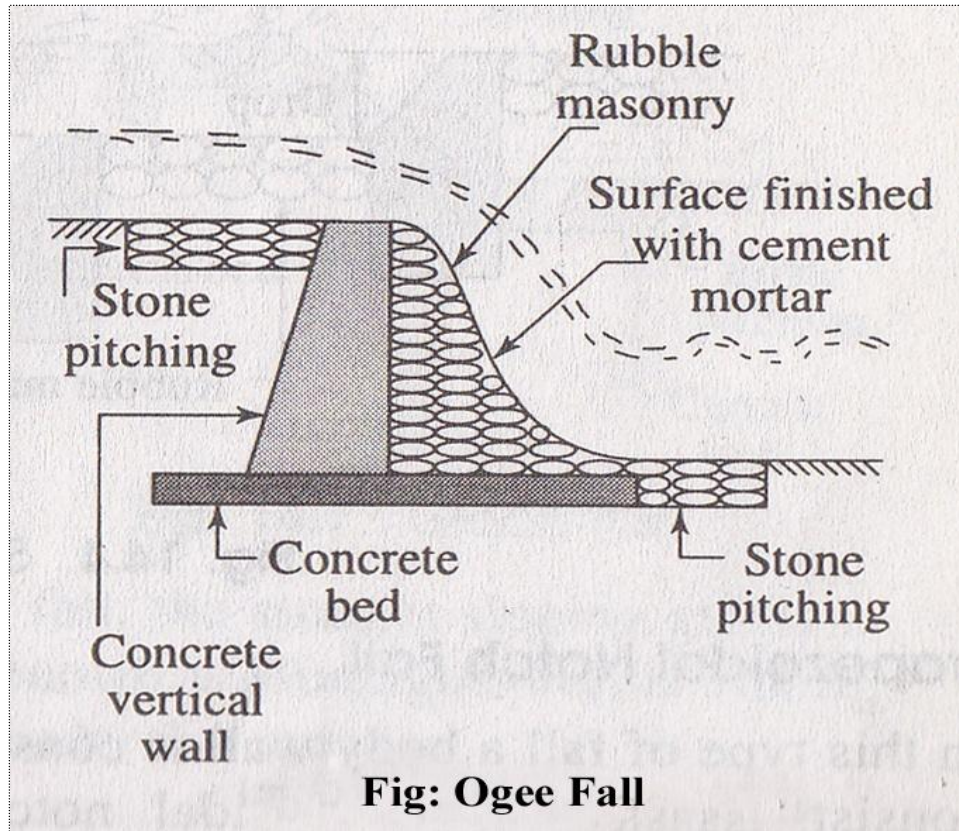

Rapid Fall

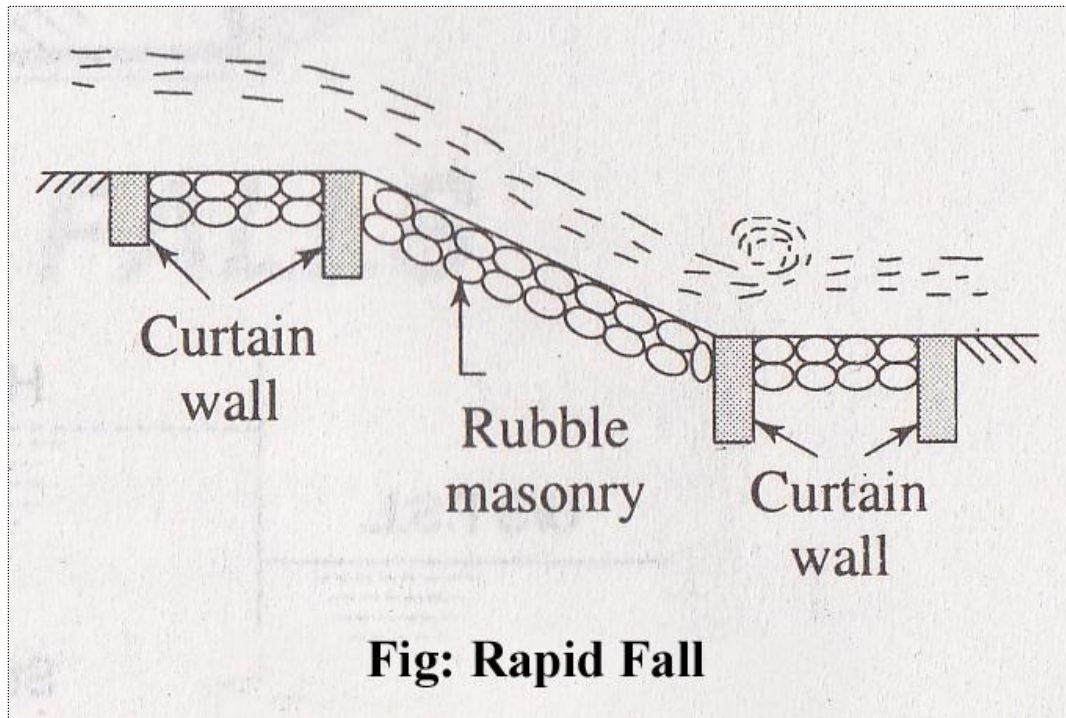

Stepped Fall

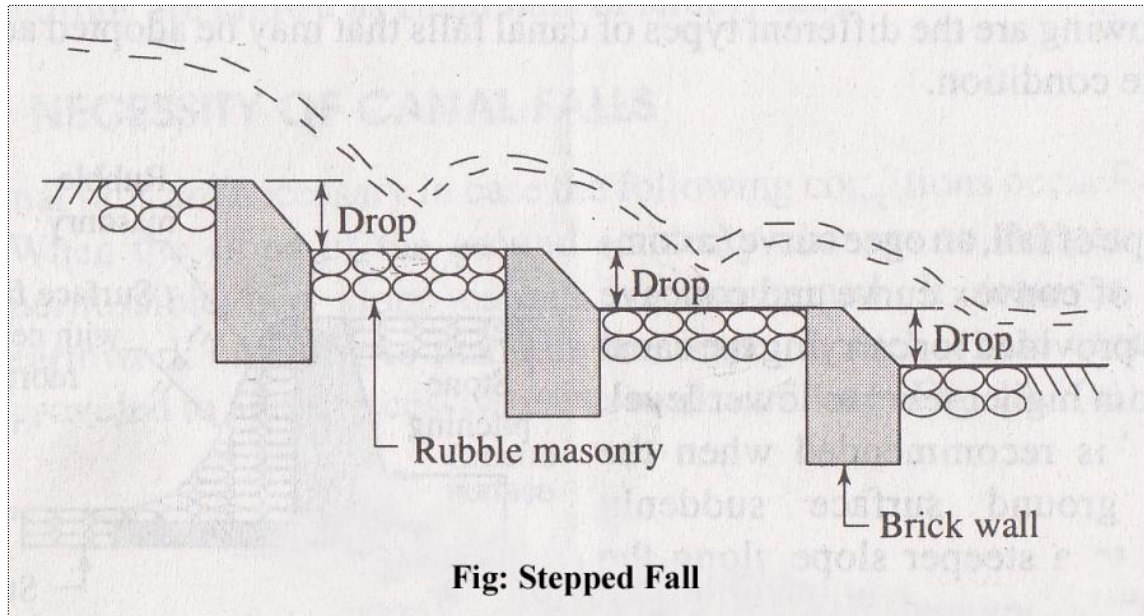

Trapezoidal Notch Fall

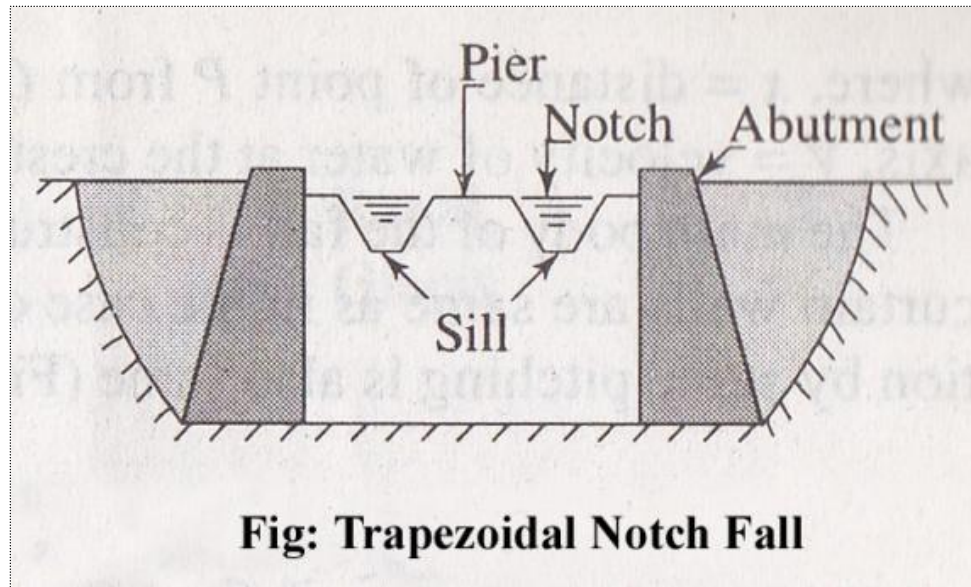

Vertical Drop Fall

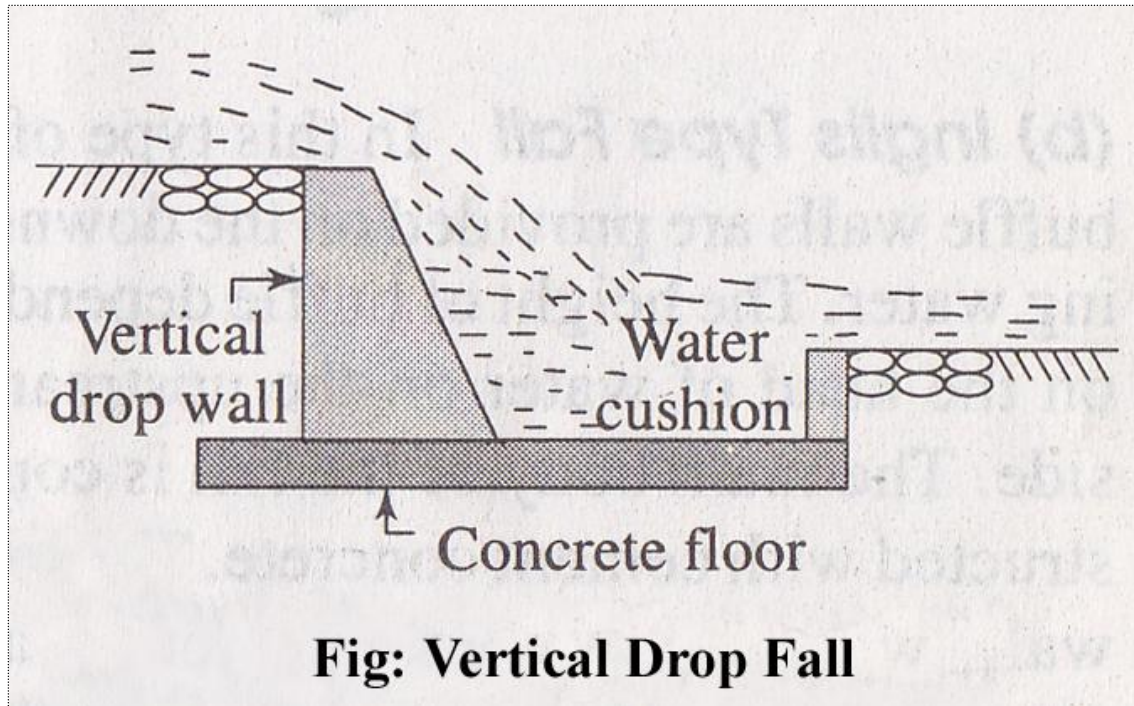

Glacis Fall

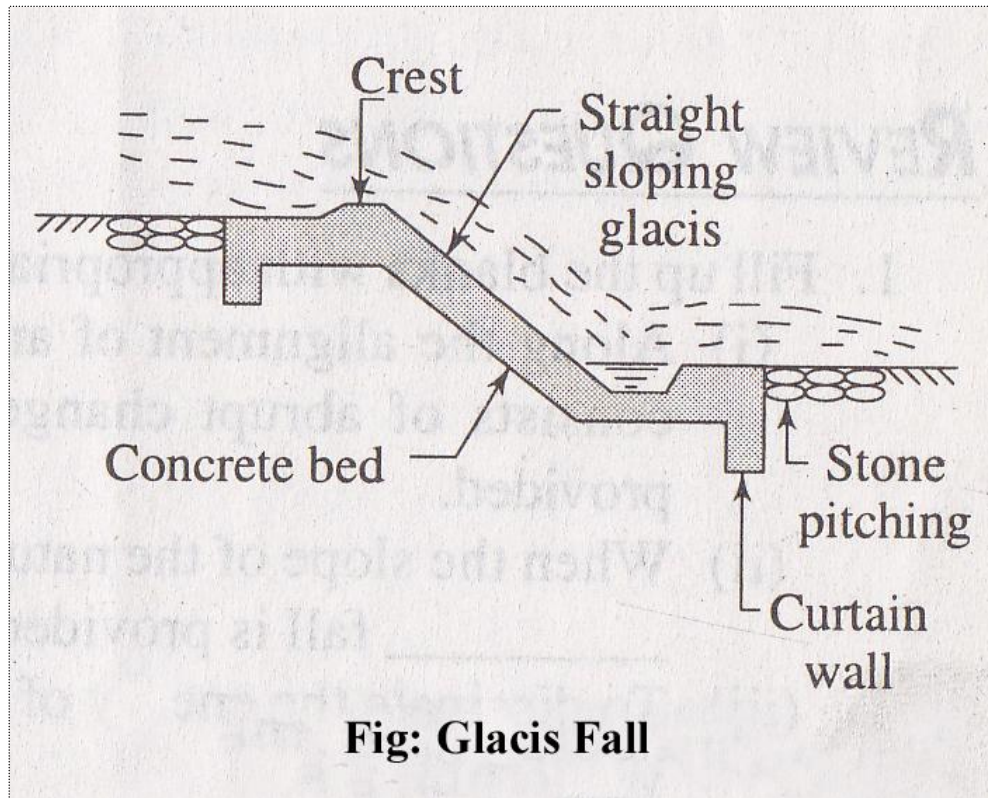

(a) Montague Type Fall

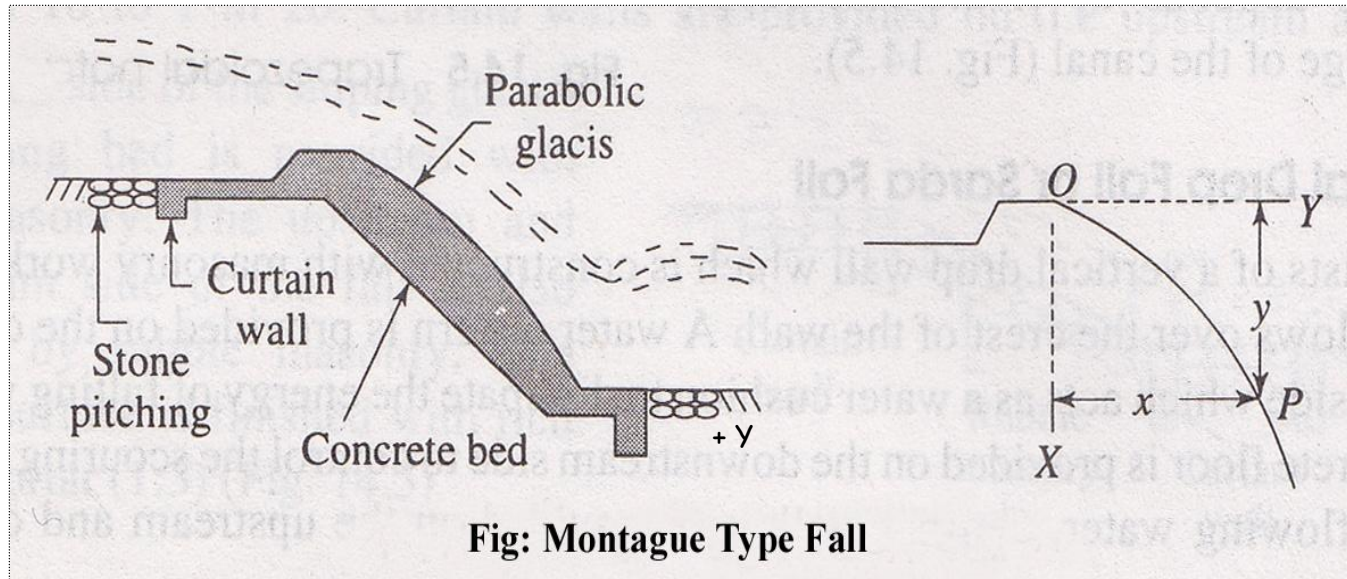

$$X = v \sqrt{\frac{4y}{g}}$$

Where, x = distance of point P from OX axis,
 Y = distance of point P from OY axis,
 v = velocity of water at the crest,
 g = acceleration due to gravity

(b) Inglis Type Fall

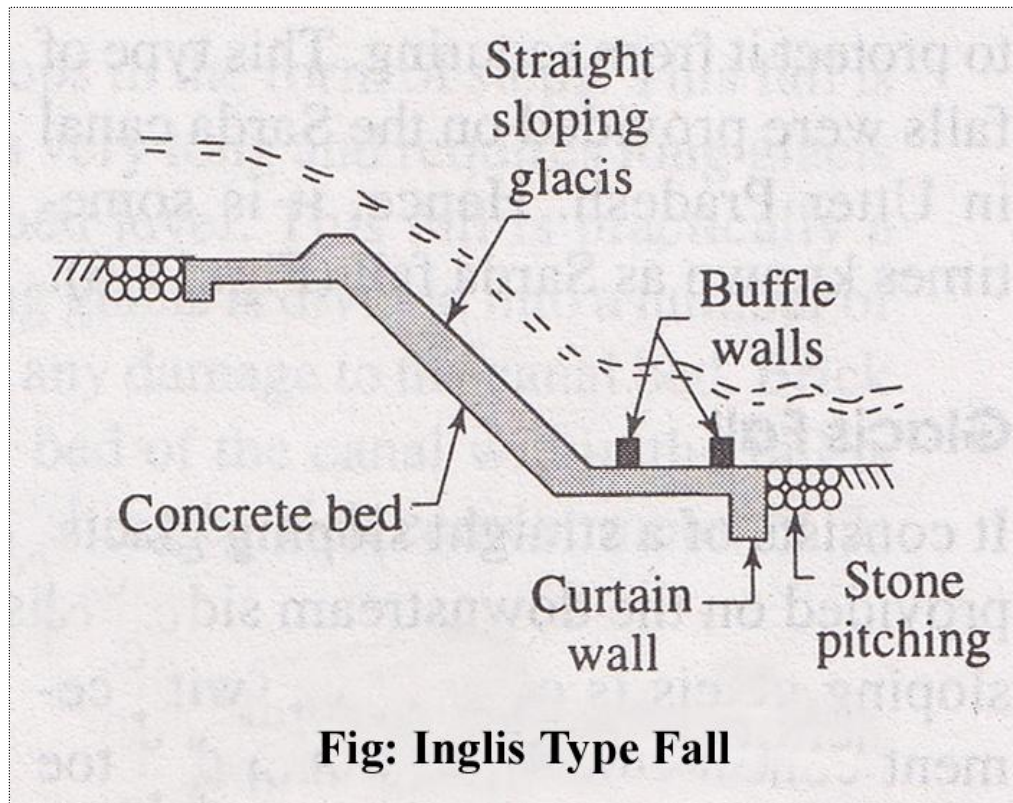

LECTURE 24



Canal Regulators

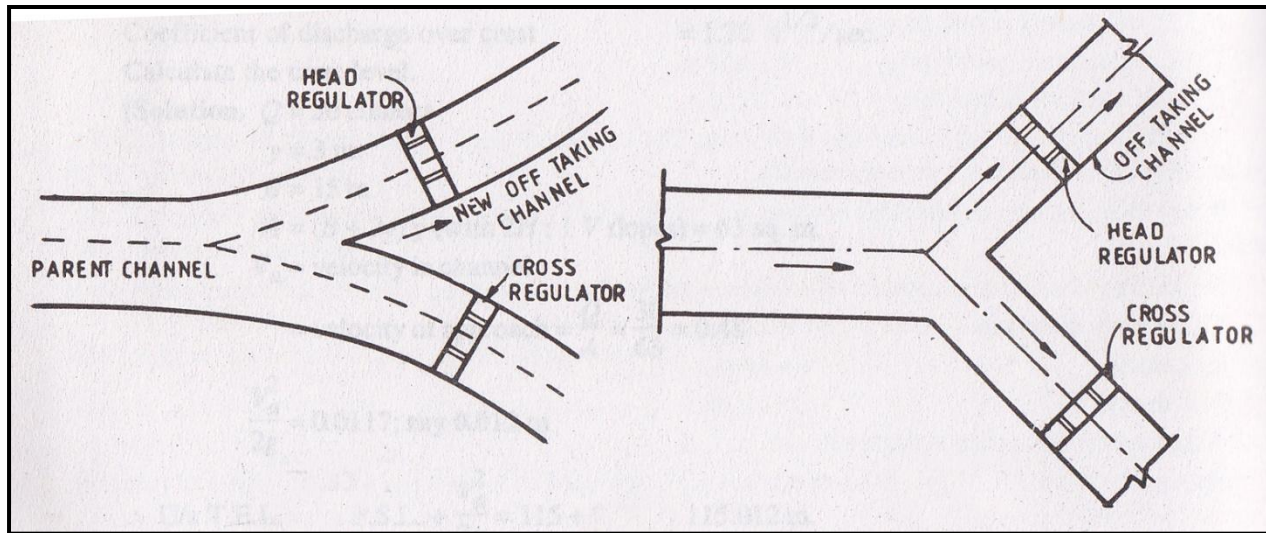

A head regulator provided at the head of the off-taking channel, controls the flow of water entering the new channel.

While a cross regulator may be required in the main channel downstream of the off-taking channel, and is operated when necessary so as to head up water on its upstream side, thus to ensure the required supply in the off-taking channel even during the periods of low flow in the main channel.

Main functions of a head regulator:

- To regulate or control the supplies entering the off-taking canal
- To control the entry of silt into the off-taking canal
- To serve as a meter for measuring discharge.

Main functions of a cross regulator:

- To control the entire Canal Irrigation System.
- To help in heading up water on the upstream side and to feed the off-taking canals to their full demand.
- To help in absorbing fluctuations in various sections of the canal system, and in preventing the possibilities of breaches in the tail reaches.
- Cross regulator is often combined with bridges and falls, if required.

Typical layout and cross-section of a regulator

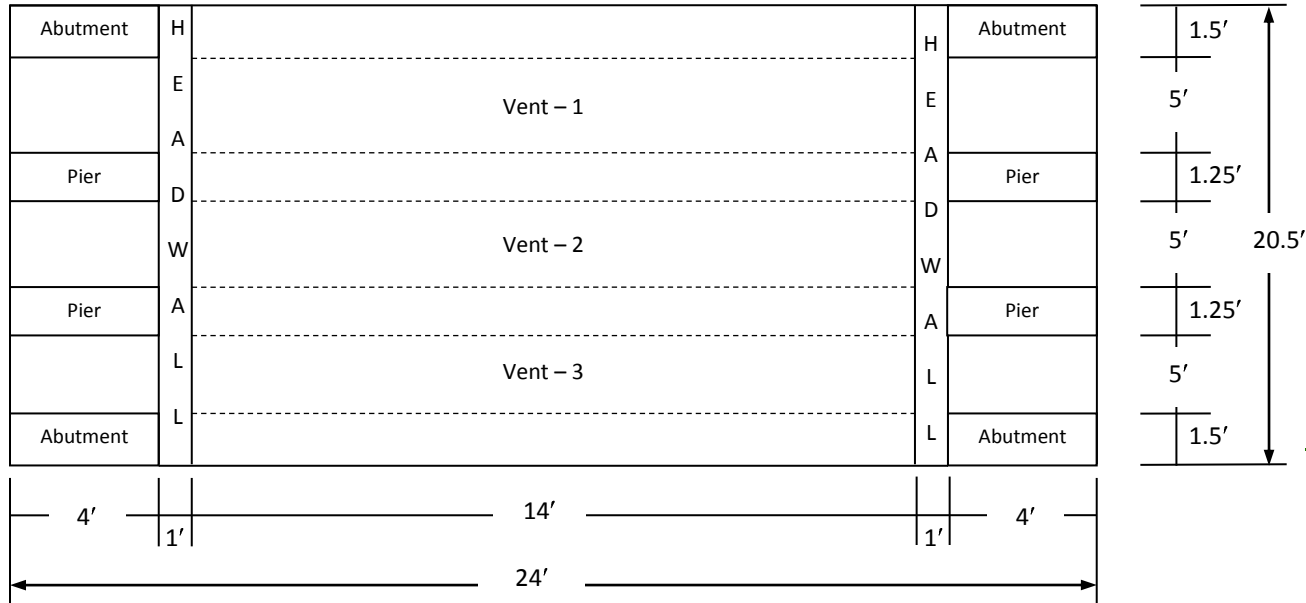

Fig: Plan view of a 3-vent regulator



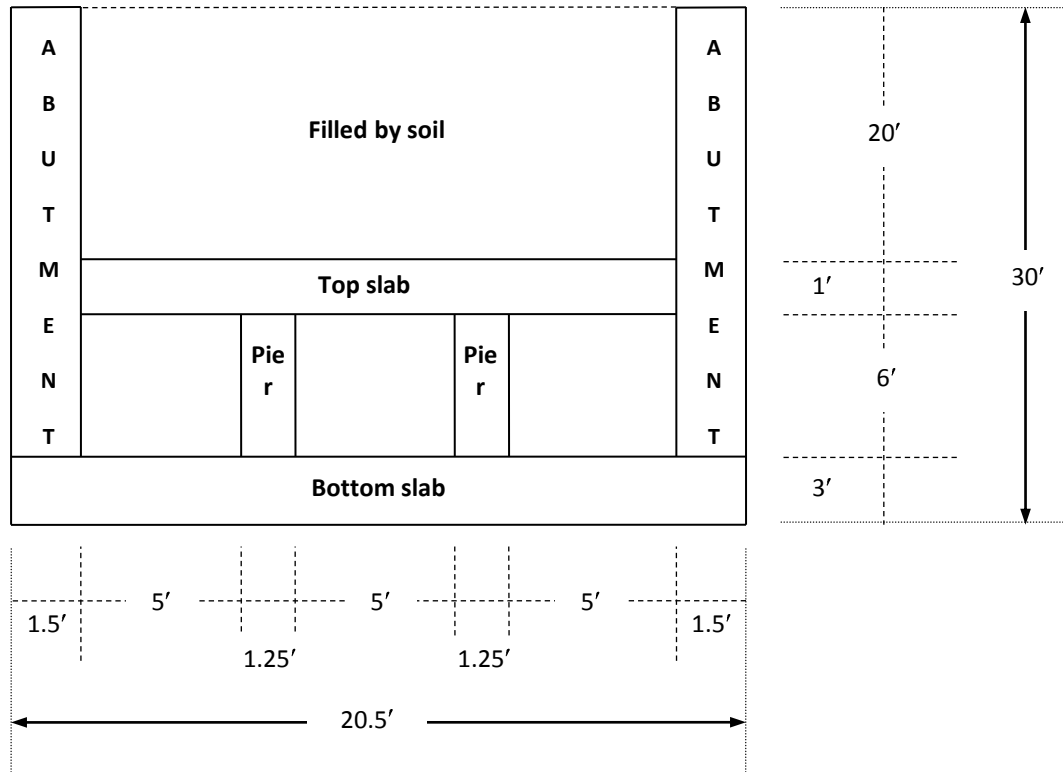

Fig: Front Elevation of a 3-vent regulator

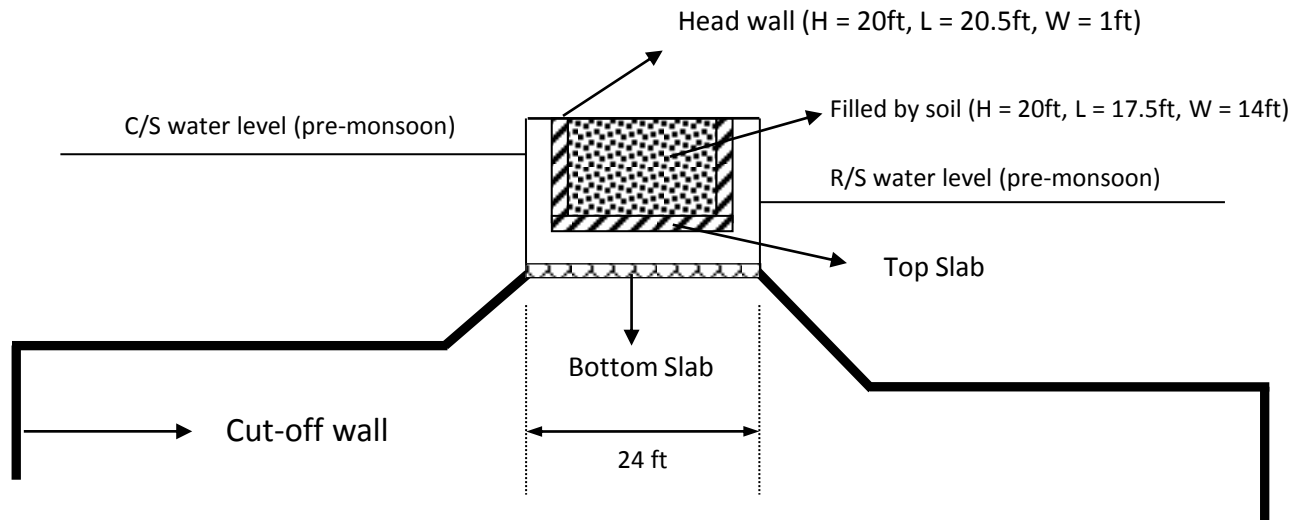

Fig: Longitudinal Section of a 3-vent regulator

Canal Escape

It is a side channel constructed to remove surplus water from an irrigation channel (main canal, branch canal, or distributary etc.) into a natural drain.

The water in the irrigation channel may become surplus due to -

- Mistake
- Difficulty in regulation at the head
- Excessive rainfall in the upper reaches
- Outlets being closed by cultivators as they find the demand of water is over

Types of Canal Escapes:

(a) Weir type escape:

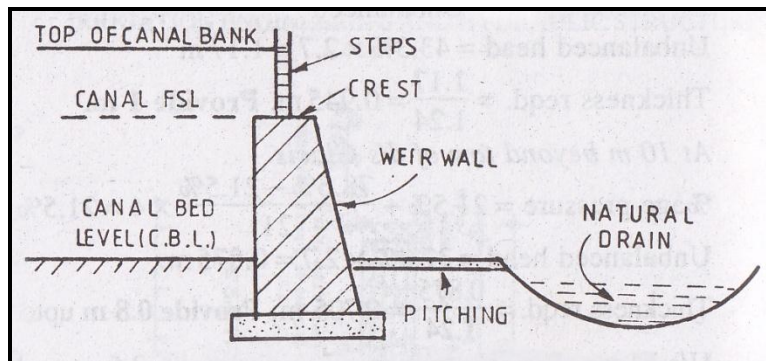

Crest level = FSL of the canal
Water escapes if $w_L > \text{FSL}$

The crest of the weir wall is kept at R.L. equal to canal FSL. When the water level rises above FSL, it gets escaped.

(a) Regulator/ sluice type escape:

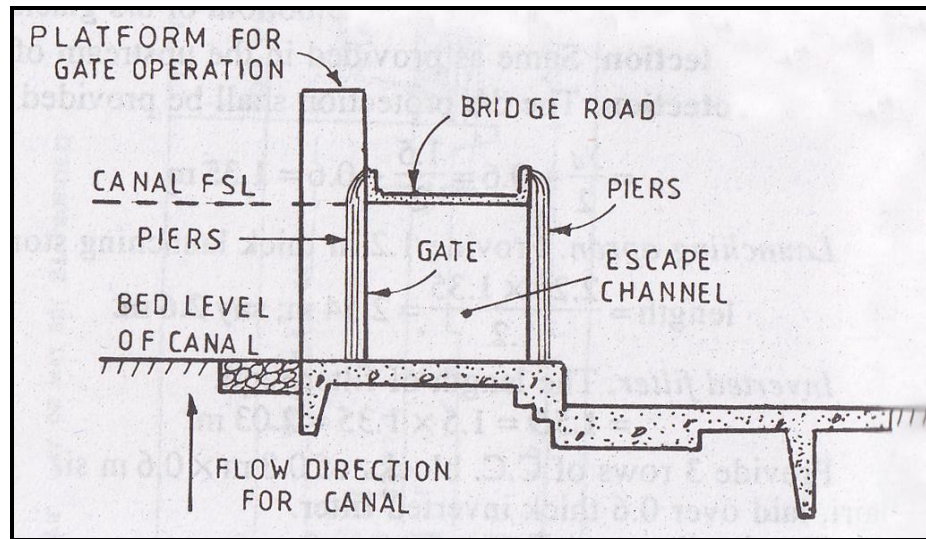

The silt of the escape is kept at canal bed level and the flow can be used for completely emptying the canal.

They may be constructed for the purpose of scouring off excess bed silt deposited in the head reaches from time to time.

Canal Outlet/modules

A canal outlet or a module is a small structure built at the head of the water course so as to connect it with a minor or a distributary channel.

It acts as a connecting link between the system manager and the farmers.

Types of Outlet/modules:

(a) Non-modular modules:

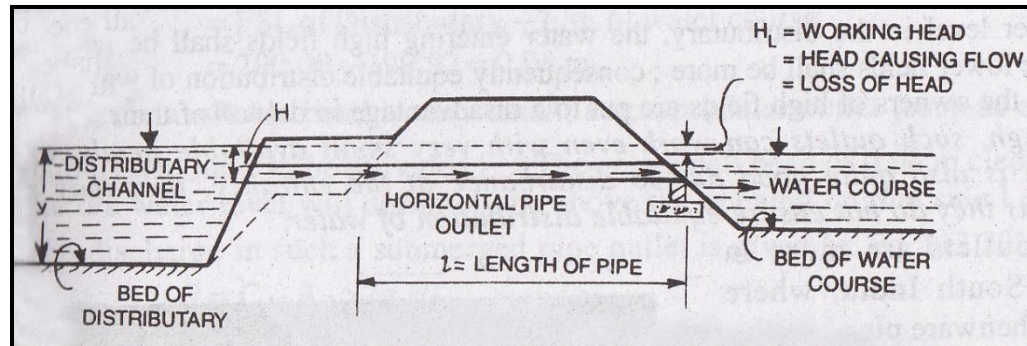

Non-modular modules are those through which the discharge depends upon the head difference between the distributary and the water course.

Common examples are:

- (i) Open sluice
- (ii) Drowned pipe outlet

(b) Semi-modules or Flexible modules:

- ❑ Due to construction, a super-critical velocity is ensured in the throat and thereby allowing the formation of a jump in the expanding flume.
- ❑ The formation of hydraulic jump makes the outlet discharge independent of the water level in water course, thus making it a semi module. Semi-modules or flexible modules are those through which the discharge is independent of the water level of the water course but depends only upon the water level of the distributary so long as a minimum working head is available.
- ❑ Examples are pipe outlet, open flume type etc.

(c) Rigid modules or Modular Outlets:

Rigid modules or modular outlets are those through which discharge is constant and fixed within limits, irrespective of the fluctuations of the water levels of either the distributary or of the water course or both.

An example is Gibb's module:

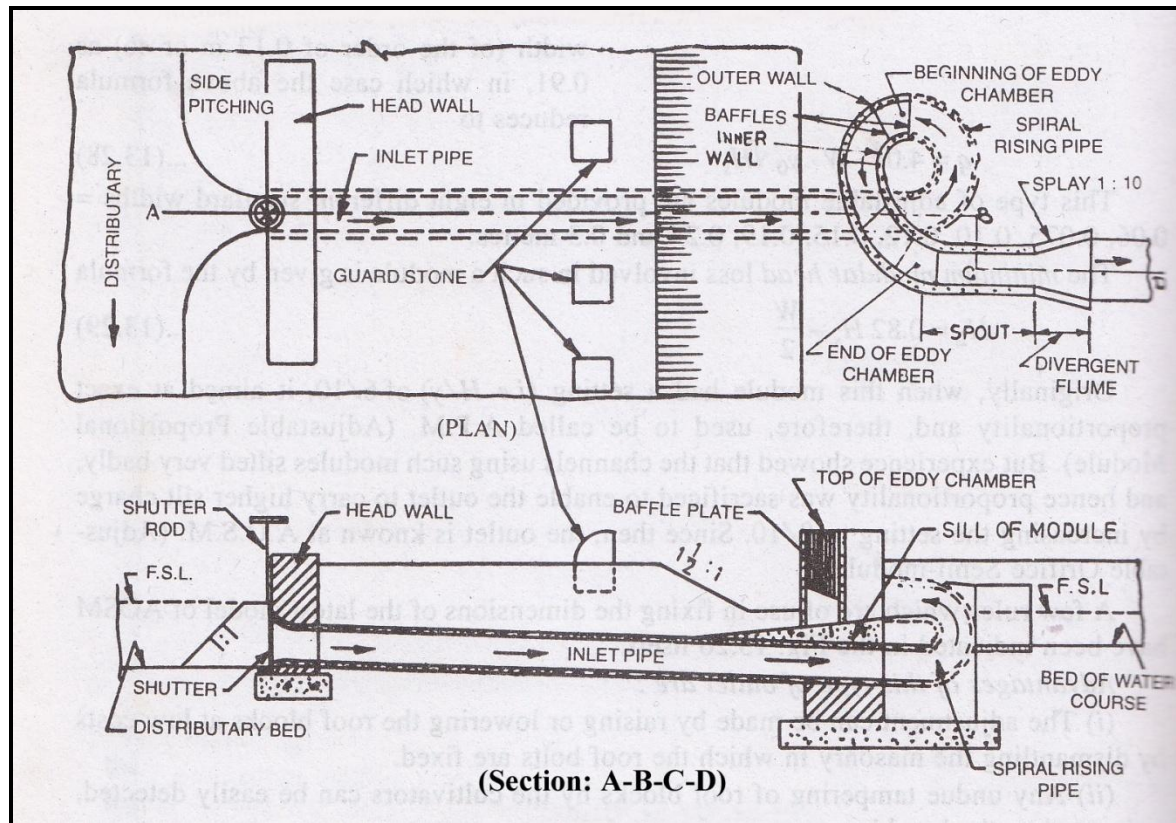

Fig: Gibb's Module

LECTURE 25



Performance Criteria

(a) Flexibility, F:

It is defined as the ratio of the rate of change of discharge of the outlet to the rate of change of discharge of the distributary channel.

$$F = \frac{dq/q}{dQ/Q}$$

Where, F = Flexibility of the outlet

q = Discharge passing through the outlet

Q = Discharge in the distributary channel

If H = the head acting on the outlet,

$$q = CH^m$$

Where, C and m are constants depending upon the type of outlet

If y = the depth of water in the distributary,

$$Q = Ky^n$$

Where, k and n are constants

$$\frac{dq}{dH} = CmH^{m-1} = (CH^m) \times (m/H) = q \times \frac{m}{H}$$

$$\Rightarrow \frac{dq}{q} = \frac{m}{H} \times dH$$

$$\text{Again, } \frac{dQ}{dy} = Kny^{n-1} = (Ky^n) \times (n/y) = Q \times \frac{n}{y} \Rightarrow \frac{dQ}{Q} = \frac{n}{y} dy$$

$$\text{Thus, } F = \frac{\frac{m}{H} \times dH}{\frac{n}{y} \times dy} = \frac{m}{n} \frac{y}{H} \frac{dH}{dy}$$

A change in water depth of the distributary (dy) would result in an equal change in the head working on the outlet (dH), so that

$$dy = dH$$

$$\text{So, } F = \frac{m}{n} \frac{y}{H}$$

(b) Proportionality:

The outlet is said to be proportional when the rate of change of outlet discharge equals the rate of change of channel discharge

$$\text{Thus } \frac{dq}{q} = \frac{dQ}{Q}$$

$$\text{So, } F = 1, \text{ i.e. } \frac{m}{n} \frac{y}{H} = 1$$

$$\Rightarrow \frac{H}{y} = \frac{m}{n} = \frac{\text{Outlet index}}{\text{Channel index}}$$

The outlet is said to be sub-proportional, if $F < 1$,

$$\text{Or, } \frac{H}{y} > \frac{m}{n}$$

The outlet is said to be hyper-proportional, if $F > 1$,

$$\text{Or, } \frac{H}{y} < \frac{m}{n}$$

(c) Setting:

It is the ratio of the depth of the silt level of the outlet below the FSL of the distributary, to the full supply depth of the distributary.

$$\text{Setting} = \frac{H}{y}$$

$$\text{For proportional outlet, setting} = \frac{H}{y} = \frac{m}{n}$$

For a wide trapezoidal channel, the discharge is proportional to $y^{5/3}$,
so, $n = 5/3$

Discharge through an orifice type outlet is proportional to $H^{1/2}$, so, $m = 1/2$

$$\text{Thus, setting} = \frac{H}{y} = \frac{m}{n} = \frac{1/2}{5/3} = \frac{3}{10} = 0.3$$

For a weir type outlet, the discharge is proportional to $H^{3/2}$

Hence, the setting for a combination of a weir type outlet and a trapezoidal channel,

$$= \frac{m}{n} = \frac{3/2}{5/3} = \frac{9}{10} = 0.9$$

Thus an orifice or a weir type outlet shall be proportional, if the outlet is set at 0.3 and 0.9 times depth below the water surface respectively.

(d) Sensitivity, S:

It is defined as the ratio of the rate of change of discharge through the outlet to the ratio of change of water level of the distributary.

$$S = \frac{\frac{dq}{dG}}{y}$$

Relation between Sensitivity and Flexibility

$$F = \frac{\frac{dq}{dQ}}{Q}$$

$$\text{But, } \frac{dq}{q} = \frac{n}{y} dy \quad \therefore F = \frac{\frac{dq}{q}}{\frac{n}{y} \times dy} = \frac{1}{n} \frac{\frac{dq}{dy}}{y}$$

Since, $dG = dy$,

$$\text{So, } F = \frac{1}{n} S$$

$$\text{Thus, } S = n F$$

For rigid modules, the discharge is fixed, and hence sensitivity is zero. The greater the variation of discharge through an outlet for a given rise or fall in water level of the distributary, the larger is the sensitivity of the outlet.

Water Measurement Structures

- (a) Constant Head Orifice
- (b) Weir
- (c) Parshall Flume
- (d) Cut Throat Flume

Purpose of measurement:

- Efficient water distribution
- Efficient water use at farm level
- Project evaluation
- Equitable distribution of limited supply
- Provides basis for water charge

Location of measurement structures:

- Headworks
- Intake of the secondary canal
- Farm outlet/turnout

(a) Constant Head Orifice (CHO)

There are two gates. The upstream gate or the orifice gate controls the size of the opening. The downstream gate or the turnout gate controls the depth below the orifice and is operated to maintain a constant head (0.2 ft)

Discharge is given by,

$$Q = C A \sqrt{2gh}$$

Where, $C = 0.7$ and $h = 0.2$ ft

Advantage:

- It can regulate and measure discharge simultaneously
- There is no problem of sediment deposit in front of the gate
- It can be used for large fluctuations of water level in the parent canal

Disadvantage:

- It collects floating debris
- Flow measurement is not so accurate
- Discharge regulation needs two gate settings

(b) Weir

Weir can be installed in case of a drop in bed level. There are different types of weirs based upon shape of the opening through water flows.

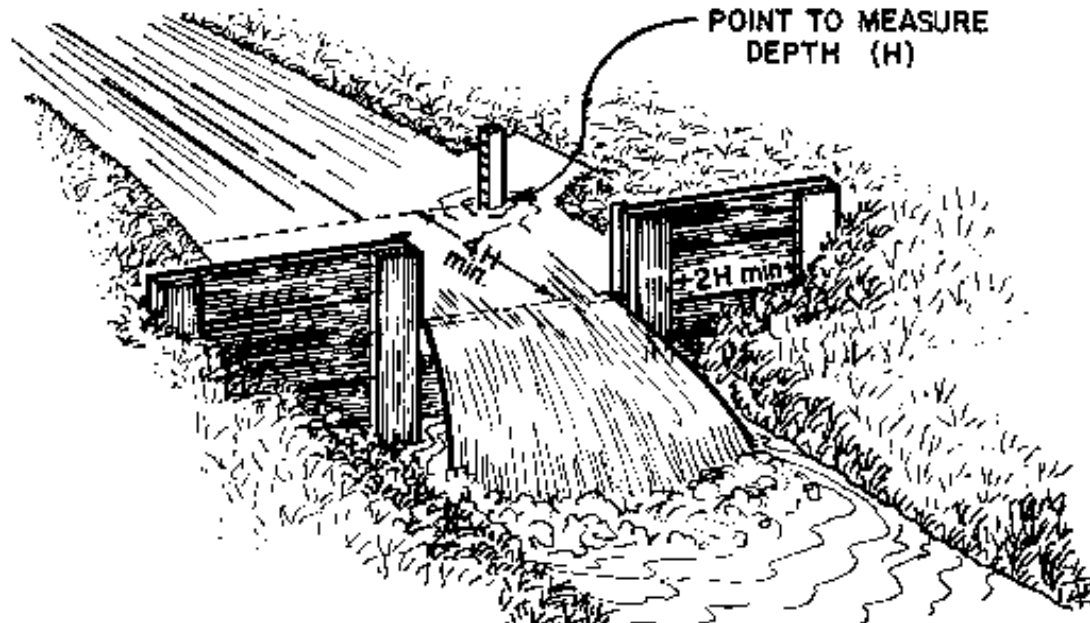

Fig: Weir

Discharge is given by,

(i) Rectangular weir:

$$Q = 1.84 \times (L - 0.2 \times H) \times H^{1.5}$$

Where,

Q = Discharge in cumec (m^3/s)

L = Length of crest (m)

H = Head (m)

(ii) Trapezoidal (Cipolletti) Weir:

$$Q = 1.86 \times L \times H^{1.5}$$

(iii) 90° V-notch Weir:

$$Q = 8/15 \times \sqrt{2g} \times \tan(\theta/2) \times H^{2.5}$$

Advantage:

- It is capable of measuring a wide range of discharge.
- It is simple and easy to construct.
- No obstruction by moss or any floating debris.
- It can be combined with turnout.
- It is durable and its accuracy is higher.

Disadvantage:

- Considerable fall in head is required.
- Silt deposition occurs in the upstream side.

Rules for setting and operating weirs:

- Weir should be placed at the lower end of a long, wide and deep pool such that $V_{\text{approach}} \leq 15 \text{ cm/s}$
- The centre line of the weir should be parallel to the direction of flow.
- The face should be vertical.
- The crest should be level.
- The upstream edge should be sharp.
- The crest height should be $\geq 3 \times H$
- The edge of the weir should be at least $2 \times H$ from the edge of the channel.
- $H \leq 1/3 \times L$
- $H \geq 15 \text{ cm}$
- Fall should be enough to provide ventilated condition.
- Weir gauge should be 5~6 time H upstream from the weir.

Parshall Flume:

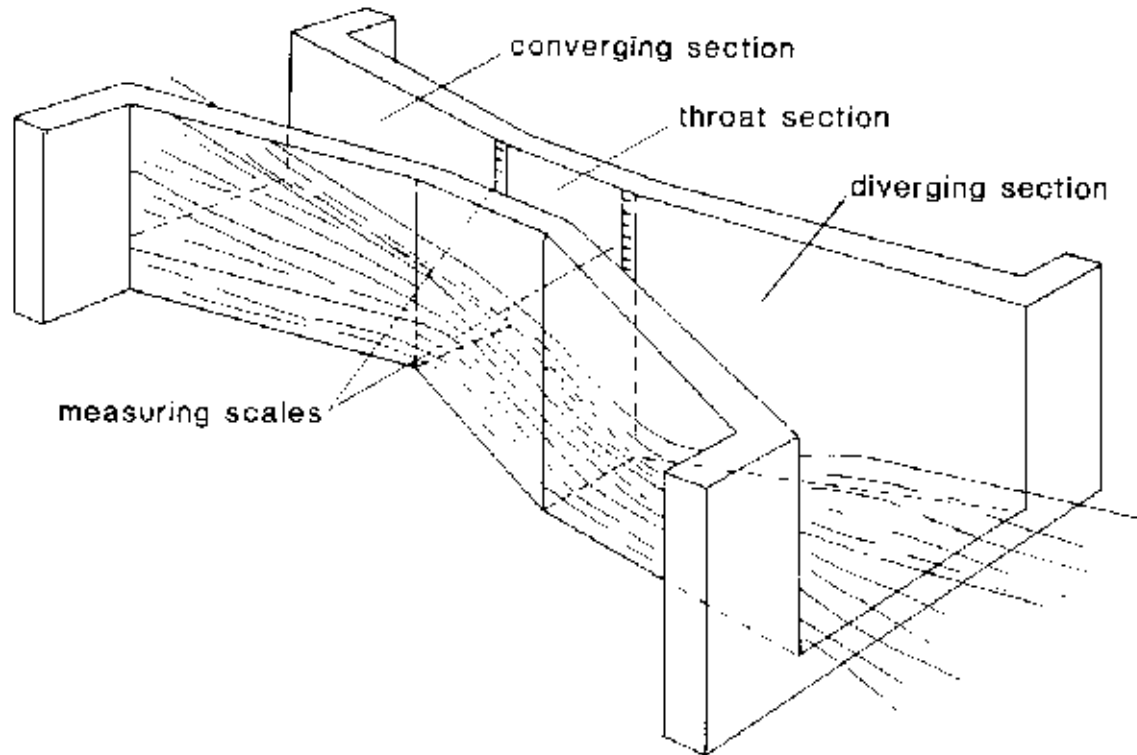

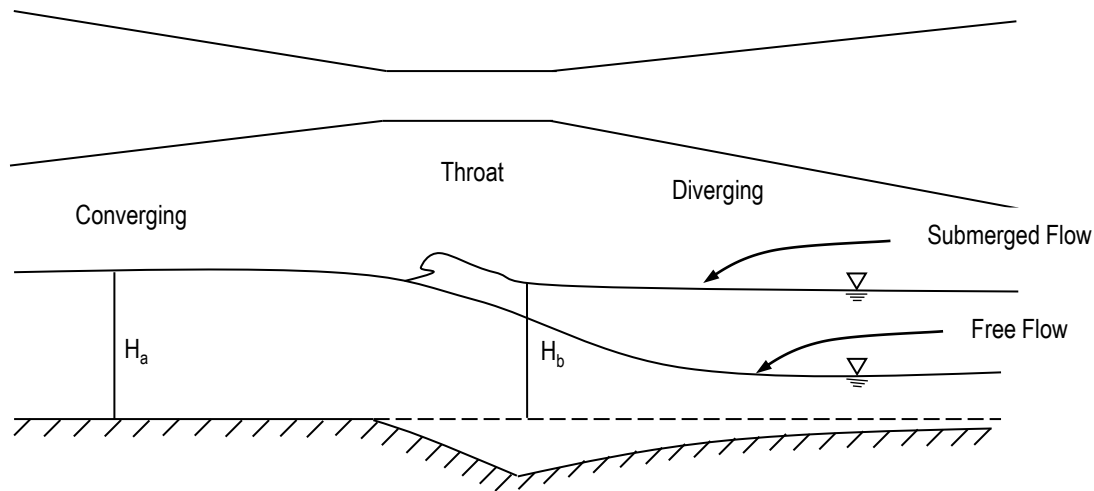

Fig: Free flow and submerged flow condition at Parshall flume

Discharge for free flow condition is given by,

$$Q_{\text{free}} = K H_a^n$$

Where,

Q = Discharge (cumec)

K = A constant depending on the system of units

n = Exponent

H_a = Upstream depth (m)

The value of K and n depend on the throat width and for 6" throat width,

$$Q_{\text{free}} = 0.3812 H_a^{1.58}$$

When H_b/H_a exceeds 0.6, submergence occurs and discharge is reduced:

$$Q = Q_{\text{free}} - Q_{\text{correction}}$$

Advantage:

- Discharge measurement is more accurate.
- It can withstand a relatively high degree of submergence over a wide range of backwater condition downstream of the structure.
- It acts as a self cleaning device.

Disadvantages:

- Complicated and costly to construct.
- Cannot be combined with a turnout.
- May become invalid in case of heavy burden of erosion debris.
- Downstream ditch needs protection under free flow condition.

(d) Cut Throat Flume:

The cut-throat flume is an attempt to improve on the Parshall flume mainly by simplifying the construction details.

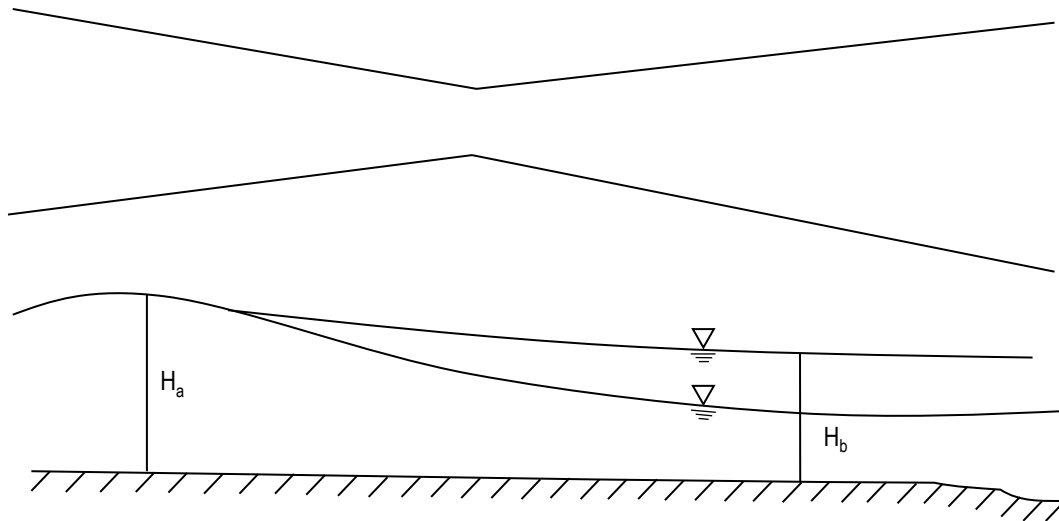

Fig: Discharge measurement by cut throat flume

Free flow condition is said to exist if $H_b/H_a \leq S_t$

Discharge for free flow condition is given by,

$$Q_{\text{free}} = C \times H_a^n$$

Where,

Q = Discharge in cumec

C = Free flow coefficient given by,

$$C = K \times W^{1.025}$$

H_a = Upstream depth (m) measured at a distance of $2L/9$ from the throat.

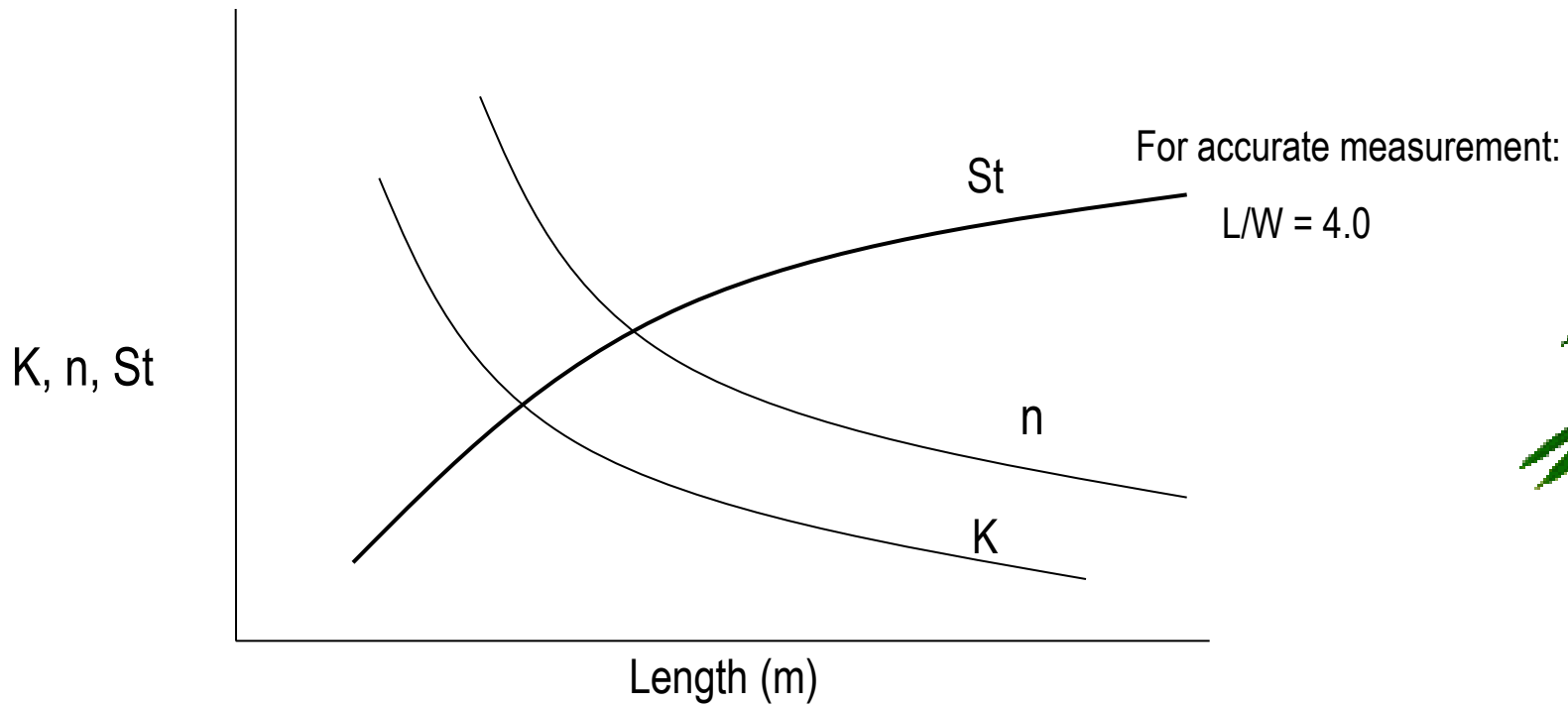

Fig: Cut-throat flume co-efficient

Advantage:

- ❑ Construction is facilitated by providing a horizontal floor and removing the throat section.
- ❑ The angle of divergence and convergence remain same for all flumes so the size of the flume can be changed by merely moving the vertical walls in or out.
- ❑ Calibration parameters remain same for a given length.
- ❑ More economic as mass fabrication is possible.

End of Chapter – 9

