

# ENGINEERING MATERIALS

[ A BASIC TEXT-BOOK FOR ENGINEERING STUDENTS ]

By

S. C. RANGWALA

B.E. (CIVIL), LL.B., M.R.S.H. (LONDON),  
M.A.C.I. (U.S.A.), M. ASCE (U.S.A.),  
M.I.E. (INDIA), M. CONS. E. (INDIA), F.I.V.

Consulting Civil Engineer

*Formerly*  
Downloaded from

Lecturer in Civil Engineering

J. D. College of Engineering

AHMEDABAD

[www.panchayatrajengineers.wordpress.com](http://www.panchayatrajengineers.wordpress.com)



{ FOURTH REVISED EDITION }

CHAROTAR BOOK STALL  
TULSI SADAN, STATION ROAD  
ANAND (W. RLY.) INDIA

ENGINEERING MATERIALS

Fourth Edition : 1969

Downloaded from  
[www.panchayatrajengineers.wordpress.com](http://www.panchayatrajengineers.wordpress.com)



Published by R. C. Patel, Charotar Book Stall, Tulsi Sadan,  
Station Road, Anand — 388-001 (W. Rly.) India  
Printed by S. Abril S. J. at Anand Press, Gamdi-Anand.

Downloaded from

[www.panchayatrajengineers.wordpress.com](http://www.panchayatrajengineers.wordpress.com)



## FOURTH EDITION

The text of this edition has been extensively revised and updated and an attempt is made to make the book up-to-date.

I am highly obliged to my good friends for sending me their valuable suggestions for improving the text-matter.

*12, Gokul Park  
Ambawadi  
Ahmedabad-380 015*

**S. C. R.**

**Downloaded from**

**[www.panchayatrajengineers.wordpress.com](http://www.panchayatrajengineers.wordpress.com)**



# CONTENTS

## CHAPTER I

PAGES

### STONES

General — Classification of rocks --- Sources of stones ---  
Rock-forming minerals—Texture or structure of a rock—  
Fracture of a rock—Uses of stones—Natural bed of stones  
---Tests for stones ---Qualities of a good building stone --  
Stone quarrying — Tools for blasting — Materials for  
blasting—Process of blasting—Precautions in blasting—  
Machines for quarrying—Dressing of stones—Deteri-  
oration of stones—Preservation of stones—Artificial  
stones—Common building stones of India—Questions . 1-45

## CHAPTER II

### CLAY PRODUCTS AND REFRACTORIES

Ceramics --- Clay products --- Tiles --- Terra-cotta --  
Earthenware -- Stoneware --- Porcelain --- Glazing ---  
Clay blocks --- Refractories --- Questions . . . . . 46-63

## CHAPTER III

### BRICKS

General — Comparison of brickwork and stonework—  
Composition of good brick earth — Harmful ingredients  
in brick earth—Classification of brick earth—Manufacture  
of bricks—Comparison between clamp-burning and kiln-  
burning—Qualities of good bricks—Tests for bricks—  
Classification of bricks—Colour of bricks—Size and weight  
of bricks — Shape of bricks — Fire-clays — Fire-bricks ---  
Sand-lime or calcium silicate bricks — Questions . . . . . 64-101

## CHAPTER IV

### LIME

Some definitions — Classification of binding materials—  
Sources of lime — Constituents of limestones—Classi-  
fication of limes—Comparison between fat lime and  
hydraulic lime — Manufacture of fat lime --- Manu-  
facture of natural hydraulic lime—Manufacture of arti-  
ficial hydraulic lime — Tests for limestones — Questions 102-119

## CHAPTER V

**CEMENT**

Definition—Cement and lime—Composition of ordinary cement—Functions of cement ingredients—Harmful constituents of cement—Setting action of cement—Site for cement factory—Manufacture of ordinary cement—Ball mills and tube mills—Field tests for cement—Laboratory tests for cement—Storage of cement—Uses of cement—Varieties of cement—Questions . . . . . 120-149

## CHAPTER VI

**MORTAR**

Definition—Sand—Natural sources of sand—Classification of sand—Bulking of sand—Properties of good sand—Function of sand in mortar—Tests for sand—Substitutes for sand—Classification of mortars—Properties of good mortar—Preparation of mortar—Uses of mortar—Precautions in using mortar—Selection of mortar—Tests for mortars—Questions . . . . . 150-167

## CHAPTER VII

**CEMENT CONCRETE**

Definition—Properties of cement concrete—Materials used in R.C.C. work—Corrosion of steel in concrete—Sea water for making concrete—Proportioning concrete—Grading of aggregates—Water-cement ratio—Workability—Estimating yield of concrete—Importance of bulking of sand—Mixing the materials of concrete—Transporting and placing of concrete—Consolidation of concrete—Curing of concrete—Water-proofing cement concrete—Coloured concrete—Lightweight concrete—Joints—Guniting—Formwork—Pre-cast concrete—Questions . . . . . 168-200

## CHAPTER VIII

**TIMBER**

Definition—Classification of trees—Soft woods and hard woods—Structure of a tree—Felling of trees—Defects in timber—Qualities of good timber—Decay of timber—

Preservation of timber— Fire-resistance of timber—Seasoning of timber — Conversion of timber — Storage of timber — Market forms of timber — Industrial timber — Advantages of timber construction — Indian timber trees — Questions . . . . . 201-256

## CHAPTER IX

### FERROUS METALS

General—Iron ores— Pig-iron—Manufacture of pig-iron — Types of pig-iron—Other methods of pig-iron manufacture — Some terms — Cast-iron — Castings — Wrought-iron — Questions . . . . . 257-281

## CHAPTER X

### STEEL

General—Manufacture of steel—Uses of steel—Factors affecting physical properties of steel—Magnetic properties of steel—Defects in steel—Market forms of steel—Mechanical treatment of steel — Heat treatment processes — Properties of mild steel—Properties of hard steel—Corrosion of ferrous metals — Questions . . . . . 282-309

## CHAPTER XI

### NON-FERROUS METALS AND ALLOYS

Non-ferrous metals—Aluminium—Cobalt — Copper—Lead — Magnesium — Nickel—Tin—Zinc—Alloys— Aluminium alloys—Copper alloys—Magnesium alloys—Nickel alloys — Steel alloys — Questions . . . . . 310-328

## CHAPTER XII

### GLASS

General—Classification of glass—Composition of glass— Properties of glass—Types of glass—Manufacture of glass — Treatment of glass—Coloured glass—Special varieties of glass—Glass industry in India—Questions . . . . . 329-345

## CHAPTER XIII

### PAINTS, VARNISHES AND DISTEMPERS

General — Painting — Varnishing — Distempering — Wall paper—Whitewashing—Colourwashing—Questions 346-372

## CHAPTER XIV

**PLASTICS**

Brief history --- Composition --- Polymerization --- Classification of plastics - Resins --- Moulding compounds --- Fabrication --- Properties of plastics --- Uses of plastics --- Conclusion --- Questions . . . . . 373-393

## CHAPTER XV

**MISCELLANEOUS MATERIALS**

General --- Abrasives --- Adhesives --- Asbestos --- Asphalt --- Belts --- Bitumen --- Cork --- Electrical insulators --- Fuels --- Gypsum --- Gypsum plaster --- Heat insulating materials --- Lubricants --- Rubber --- Sheets for pitched roof coverings --- Solder --- Sound absorbent materials --- Tar --- Turpentine --- Questions . . . . . 394-431

## CHAPTER XVI

**PROPERTIES OF BUILDING MATERIALS**

General --- Physical properties --- Mechanical properties---  
 Questions . . . . . 432-440  
 BIBLIOGRAPHY . . . . . 441  
 INDEX . . . . . 442-445

**Downloaded from**

**[www.panchayatrajengineers.wordpress.com](http://www.panchayatrajengineers.wordpress.com)**



# Chapter 1

Downloaded from  
[www.panchayatrajengineers.wordpress.com](http://www.panchayatrajengineers.wordpress.com)



## STONES

### General:

Engineering structures are composed of materials. These materials are known as *engineering materials* or *building materials* or *materials of construction*. It is necessary for an engineer to become conversant with the properties of such materials.

The service conditions of buildings demand a wide range of materials and various properties such as water resistance, strength, durability, temperature resistance, appearance, permeability, etc. are to be properly studied before making final selection of any building material for a particular use. It is significant to note that a universal building material for application in all conditions is yet to be found out.

The grouping of building materials is done by considering specific properties of the materials such as stones, ceramics, cement concrete, timber, metals, etc. Each group is then suitably sub-divided. The application of each building material in the engineering field is predetermined by its chief or main properties. When alternatives are available, the final choice is made from the considerations of engineering and economics.

To improve the quantity and quality aspects of industry of building materials, it becomes necessary to impose standardisation and only by such regulations and restrictions in the manufacturing processes, it becomes possible to supply the conventional building materials at an economic rate in the market.

It is an established fact that the supply of building materials lags far behind its demand. This is due to the fact that the use of building materials is not limited to construction purposes alone. As a matter of fact, there is no field of engineering which does not require the use of the building materials. The industry of building materials, therefore, plays a vital role in our national economy.

In this chapter, stones as a sort of building material, will be discussed. In subsequent chapters, other building materials will be described.

### **Classification of rocks:**

Building stones are obtained from rocks which are classified in *three* ways:

- (1) Geological classification
- (2) Physical classification
- (3) Chemical classification.

#### **(1) Geological classification:**

According to this classification, rocks are of the following *three* types:

- (i) igneous rocks;
- (ii) sedimentary rocks; and
- (iii) metamorphic rocks.

##### **(i) Igneous rocks:**

Inside portion of the earth's surface has high temperature so as to cause *fusion* by heat at even ordinary pressures. Molten or pasty rocky material is known as *magma* and this magma occasionally tries to come out to the earth's surface through cracks or weak portions. Rocks which are formed by the cooling of magma are known as *igneous rocks*.

Igneous rocks are recognised in the following *three* classes:

##### **(a) Plutonic rocks:**

Such rocks are formed due to cooling of magma at a considerable depth from earth's surface. The cooling is slow and rocks possess coarsely grained crystalline structure. Igneous rocks commonly used in building industry are of plutonic type. Granite is the leading example of this type of rock.

##### **(b) Hypabyssal rocks:**

Such rocks are formed due to cooling of magma at a relatively shallow depth from earth's surface. The cooling is quick and hence, these rocks possess finely grained crystalline structure. Dolerite is an example of this type of rock.

(c) Volcanic rocks:

Such rocks are formed due to pouring of magma at earth's surface. The cooling is very rapid as compared to the previous two cases. Hence these rocks are extremely fine grained in structure. They frequently contain some quantity of glass which is a non-crystalline material. Basalt is an example of this type of rock.

(ii) *Sedimentary rocks:*

These rocks are formed by the deposition of products of weathering on the pre-existing rocks. All the products of weathering are ultimately carried away from their place of origin by the agents of transport. Such agents are frost, rain, wind, etc. Following *four* types of deposits occur:

(a) Residual deposits:

Some portion of the products of weathering remain at the site of origin. Such a deposit is known as a residual deposit.

(b) Sedimentary deposits:

The insoluble products of weathering are carried away in suspension and when such products are deposited, they give rise to sedimentary deposits.

(c) Chemical deposits:

Some material, that is carried away in solution, may be deposited by some physio-chemical processes such as evaporation, precipitation, etc. It gives rise to chemical deposits.

(d) Organic deposits:

Some portion of the product of weathering gets deposited through the agency of organisms. Such deposits are known as organic deposits.

Examples of sedimentary rocks are gravel, sandstone, limestone, gypsum, lignite, etc.

(iii) *Metamorphic rocks:*

These rocks are formed by the change in character of the pre-existing rocks. Igneous as well as sedimentary rocks are changed in character when they are subject to great

heat and pressure. The process of change is known as metamorphism.

Mineral composition and texture of a rock represent a system which is in equilibrium with its physio-chemical surroundings. Increase of temperature and pressure upsets this equilibrium and metamorphism results from an effort to re-establish a new equilibrium. In this process, original constituent minerals which are unstable under the changed conditions are converted into new ones which are more stable under the changed conditions. These minerals are arranged in a manner which is more suitable to the new environments. It should, however, be noted that changes produced by weathering and sedimentation are not included in metamorphism.

There are *three* agents of metamorphism, namely, heat, pressure and chemically acting fluids. Heat may be supplied by the general rise of temperature with depth or by igneous magma. Pressure may be developed due to load of rocks or movement of the earth. Chemically acting fluids play a passive role only and they do not take active part in the process of metamorphism.

Pressure may be uniform or directed. Uniform pressure may be applied to solids and liquids. Directed pressure or stress can exist only in solids and it is converted into uniform pressure, if applied to liquids. Following *four* types of metamorphism occur with various combinations of heat, uniform pressure and directed pressure:

(a) Thermal metamorphism:

Heat is the predominant factor in this type of metamorphism.

(b) Cataclastic metamorphism:

At the surface of earth, temperatures are low and metamorphism is brought about by directed pressure only. Such metamorphism is known as cataclastic metamorphism.

(c) Dynamo-thermal metamorphism:

There is a rise in temperature with increase in depth. Hence, heat in combination with stress, brings about the

changes in rock. Such metamorphism is known as dynamothermal metamorphism.

(d) **Plutonic metamorphism:**

Stress is effective only upto a certain depth. This is due to the fact that rocks become plastic in nature at certain depths. At great depths, a stage is reached when stress cannot exist as it is converted into uniform pressure because of the plasticity of rocks. Metamorphic changes at great depths are, therefore, brought about by uniform pressure and heat. Such metamorphism is known as plutonic metamorphism.

(2) ***Physical classification:***

This classification is based on general structure of rocks. According to this classification, rocks are of the following *three* types:

- (i) stratified rocks;
- (ii) unstratified rocks; and
- (iii) foliated rocks.

(i) ***Stratified rocks:***

These rocks possess planes of stratification or cleavage and such rocks can easily be split up along these planes. Sedimentary rocks are distinctly stratified rocks.

(ii) ***Unstratified rocks:***

These rocks are unstratified. The structure may be crystalline granular or compact granular. Igneous rocks of volcanic agency and sedimentary rocks affected by movements of the earth are of this type of rocks.

(iii) ***Foliated rocks:***

These rocks have a tendency to be split up in a definite direction only. Foliated structure is very common in case of metamorphic rocks.

(3) ***Chemical classification:***

According to this classification, rocks are of the following *three* types:

- (i) silicious rocks;
- (ii) argillaceous rocks; and
- (iii) calcareous rocks.

(i) *Silicious rocks:*

In these rocks, silica predominates. The rocks are hard and durable. They are not easily affected by the weathering agencies. Silica, however, in combination with weaker minerals, may disintegrate easily. It is therefore necessary that these rocks should contain maximum amount of free silica for making them hard and durable. Granites, quartzites, etc. are examples of silicious rocks.

(ii) *Argillaceous rocks:*

In these rocks, clay predominates. Such rocks may be dense and compact or they may be soft. Slates, laterites, etc. are examples of silicious rocks.

(iii) *Calcareous rocks:*

In these rocks, calcium carbonate predominates. The durability of these rocks will depend upon the constituents present in surrounding atmosphere. Limestones, marbles, etc. are examples of calcareous rocks.

### **Sources of stones:**

Stones are obtained from rocks. A rock represents a definite portion of earth's surface. It is not homogeneous. It has no definite chemical composition and shape. It is known as *monomineralic rock*, if it contains only one mineral and it is known as *polymineralic rock*, if it contains several minerals. Quartz sand, chemically pure gypsum, magnesite, etc. are examples of monomineralic rocks and basalt, granite, etc. are examples of polymineralic rocks.

A mineral indicates a substance having definite chemical composition and molecular structure. It is formed by natural inorganic processes. Such minerals, when combine, form rocks of various types as discussed earlier. Properties of a rock are then governed by the properties of minerals present in its structure.

**Rock-forming minerals:**

Igneous rocks contain many minerals. Various natural minerals having wide range of different distinctive characteristics are available. But only few of them form the bulk of rocks. These minerals are called the rock-forming minerals. Following are the commonly found minerals in igneous rocks:

(1) *Augite*:

This mineral resembles hornblende. It forms octagonal crystals. It changes to chlorite by hydration.

(2) *Chlorite*:

It has green colour. It is mainly derived from the decomposition of augite, biotite and hornblende.

(3) *Felspar*:

It has many varieties, the common being that of orthoclase, microcline and one or other member of the plagioclase series. Orthoclase is whitish, greyish or pinkish in colour. It is a straight-splitting mineral. It shows development of tabular crystals. It has usually well defined faces. Presence of decomposed rocks sometimes impart cloudy appearance to this mineral. Rocks disintegrate easily, if orthoclase is in abundance in their structure. Microcline has deep green or flesh-red colour. It is found alongwith orthoclase.

(4) *Hornblende*:

This mineral is heavy, strong and durable. Its colour is dark-green or black. It has glassy lustre. It frequently occurs as six-sided crystals having the appearance of elongated hexagons. It changes to chlorite when exposed to weather.

(5) *Mica*:

It occurs in thin transparent laminae or plates. Layers of mica shine with metallic lustre. The hardness varies from 2 to 3. Two forms of mica commonly occurring in igneous rocks are muscovite and biotite. They occur separately or simultaneously.

Muscovite is also known as white mica. It has light colour and it may be colourless, when available in thin layers. Its density varies from 2.76 to 3.10 g/cm<sup>3</sup>.

Biotite is also known as black mica. It has dark colour and metallic lustre. It has iron content and hence, when exposed to weather, it changes to chlorite and loses its elasticity. Its density varies from 2.80 to 3.20 g/cm<sup>3</sup>.

(6) *Olivine*:

It has black, olive-green or yellow colour. It is colourless when found in thin sections. It frequently changes to serpentine.

(7) *Plagioclase*:

This is a general name given to a series of feldspars which ranges from sodium aluminium silicate known as albite to calcium aluminium silicate, known as anortite. The characteristic of plagioclase is multiple twinning. It is an oblique-splitting mineral.

(8) *Quartz*:

It is the crystalline form of silica. It is usually colourless. But it may be sometimes brownish, pink or yellow in colour due to presence of metallic oxides in small quantities. It is weather-proof and resists the attack of acids with the exception of hydrofluoric acid. Its density is 2.65 g/cm<sup>3</sup> and its hardness is 7. It may be noted that common sand is a variety of quartz.

(9) *Serpentine*:

This mineral resembles chlorite. It has pale-green or yellow colour. It presents a massive appearance.

Sedimentary rocks also contain many minerals. Following are the commonly found minerals in sedimentary rocks:

(1) *Calcite*:

This mineral rarely occurs in igneous rocks. But it is the chief constituent of many sedimentary rocks. Calcite is calcium carbonate CaCO<sub>3</sub> and it gives out carbon dioxide when attacked by mineral acids. It is generally colourless. But presence of impurities may give it yellow, brown or red colour. It is available in various shades.

It is poorly soluble in water and it reacts vigorously with

acids. Its density is  $2.70 \text{ g/cm}^3$  and its hardness is 3. It deteriorates in water containing carbon dioxide  $\text{CO}_2$  since calcium bicarbonate  $\text{Ca}(\text{HCO}_3)_2$  is formed and it is about 100 times more soluble in water than calcite.

(2) *Magnesite* :

This mineral occurs rarely in nature and its chemical composition is  $\text{MgCO}_3$ . It is harder and less soluble than calcite.

(3) *Dolomite* :

It is available in various shades. Its crystals are brittle. It is, however, stronger and heavier than calcite. It is insoluble in ordinary water. In chemical composition, it is a bicarbonate of magnesium and calcium,  $\text{MgCO}_3 \cdot \text{CaCO}_3$ .

(4) *Glauconite* :

This mineral has no definite crystal form. Its colour varies from yellow to green. It is practically insoluble in acids as well as ordinary water.

(5) *Limonite* :

It has an earthy appearance. Its colour varies from yellow to reddish brown. It is insoluble in ordinary water. But it dissolves in acids.

(6) *Gypsum* :

It is the hydrated sulphate of calcium with chemical composition as  $\text{CaSO}_4 \cdot 2\text{H}_2\text{O}$ . It is white, when in pure state. Due to presence of impurities, it is tinted into grey, reddish, yellowish or black colours. Its density is  $2.3 \text{ g/cm}^3$  and its hardness is 2. It is a crystalline substance. Its solubility in water is very poor.

(7) *Anhydrate* :

This is an anhydrous variety of gypsum and its chemical composition is  $\text{CaSO}_4$ . Its colour varies from reddish-white to grey. Its density varies from  $2.80$  to  $3.00 \text{ g/cm}^3$  and its hardness varies from  $3.00$  to  $3.50$ . If it remains in contact with water for a long time, it is converted into gypsum with a slight increase in volume.

**Texture or structure of a rock:**

The arrangement of minerals forming a rock is known as its *texture* or structure. Following are the different types of textures:

(1) *Compact crystalline:*

Fine grains or particles are held together in a compact crystalline form, e.g., marble, quartzite, etc.

(2) *Conglomerate:*

Grains are round and of different sizes. They are cemented by some binding material.

(3) *Foliated:*

In this type of texture, the arrangement of minerals is in the form of parallel layers.

(4) *Glassy:*

It is like glass without any crystal.

(5) *Granular crystalline:*

Crystals are of similar size. They are separate. But they are held together by some binding materials, e.g., sandstone, gneiss, etc.

(6) *Pisolitic:*

Grains are bigger in size and they are as large as peas.

(7) *Porous granular:*

Grains are in the form of irregular minute particles and a rock with such texture is not durable.

(8) *Porphyritic:*

In this type of texture, crystals of one or more minerals are large and predominant.

(9) *Vesicular:*

This texture is indicated by small irregular cavities on rock surface.

**Fracture of a rock:**

Type of surface obtained, when a rock is broken,

indicates its fracture. For rocks with cleavage, the breaking should be done in a direction other than that of cleavage. Fracture of a rock helps to determine its texture. Fractured surfaces are mostly irregular. Their different types are as follows:

(1) *Conchoidal*:

Such a fracture presents a set of concentric rings, e.g., quartz, flint, etc.

(2) *Earthy*:

It resembles earth, e.g., chalk.

(3) *Even*:

Fracture surface is more or less plane. Such a fracture denotes crystalline texture.

(4) *Fibrous*:

Fracture surface is in the form of fibres as in case of asbestos.

(5) *Hackly*:

It indicates rough and broken surface with sharp edges.

(6) *Uneven*:

Fracture surface is rough due to minute elevations and depressions. Such a fracture indicates granular texture.

### **Uses of stones:**

Stones are used in the construction of buildings from the very ancient times. Even at present, they form a basic material for cement concrete and bricks. Following are various uses to which stones are employed:

(1) *Structure*:

Stones are used for foundations, walls, columns, lintels, arches, etc.

(2) *Face-work*:

Stones are adopted to give massive appearance to the structure. Walls are of bricks and facing is done in stones of desired shades. This is known as composite masonry.

(3) *Paving:*

Stones are used to cover floor of buildings of various types such as residential, commercial, industrial, etc. They are also adopted to form paving of roads, footpaths, etc.

(4) *Basic material:*

Stones are disintegrated and converted to form a basic material for cement concrete, murrum of roads, calcareous cements, artificial stones, hollow blocks, etc.

(5) *Miscellaneous:*

In addition to above uses, stones are also used as:

- (i) ballast for railways,
- (ii) flux in blast furnaces,
- (iii) blocks in the construction of bridges, piers, abutments, retaining walls, light houses, dams, etc.

### **Natural bed of stones:**

#### ***Definition:***

Building rocks are obtained from rocks. These rocks have a distinct plane of division along which stones can easily be split. This plane is known as *natural bed of stone*.

#### ***Importance:***

In stone masonry, the general rule to be observed is that the direction of natural bed should be perpendicular or nearly so to the direction of pressure. Such an arrangement gives maximum strength to stonework.

Natural beds of stones can be detected by pouring water and examining the directions of layers. Magnifying glass may also be used for this purpose. An experienced worker can easily locate the direction of natural bed of stones from the resistance offered to the chisel. Stones break easily along these natural beds.

With respect to natural bed, stones are placed in different situations as follows:

(1) *Arches:*

In stone arches, stones are placed with their natural beds radial as shown in fig. 1-1. With such an arrangement, the thrust of arch acts normal to the direction of natural beds.

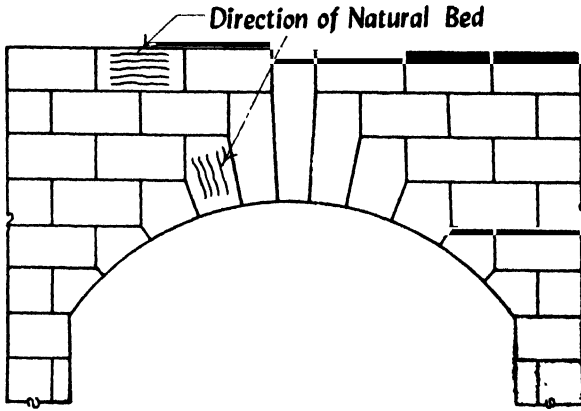

Natural bed of stone

FIG. 1-1

(2) *Cornices, string courses, etc.:*

Stones are partially unsupported in case of cornices, string courses, etc. Hence they should be placed with direction of natural beds as vertical. This principle will not hold good for corner stones. It would be desirable, in such cases, to adopt stones without natural beds.

(3) *Walls:*

Stones should be placed in walls with the direction of their natural beds horizontal as shown in fig. 1-1.

**Tests for stones:**

Building stones are to be tested for their different properties. Following are such tests for the stones:

- (1) Acid test
- (2) Attrition test
- (3) Crushing test
- (4) Crystallisation test
- (5) Freezing and thawing test
- (6) Hardness test

- (7) Impact test
- (8) Microscopic test
- (9) Smith's test
- (10) Water absorption test.

**(1) Acid test:**

In this test, a sample of stone weighing about 50 to 100 gm is taken. It is placed in a solution of hydrochloric acid having strength of one per cent and it is kept there for seven days. Solution is agitated at intervals. A good building stone maintains its sharp edges and keeps its surface free from powder at the end of this period. If edges are broken and powder is formed on the surface, it indicates the presence of calcium carbonate and such a stone will have poor weathering quality. It is natural that this test cannot be applied to limestones. This test is usually carried out on sandstones.

**(2) Attrition test:**

This test is done to find out the rate of wear of stones, which are used in road construction. The results of test indicate the resisting power of stones against the grinding action under traffic. Following procedure is adopted:

- (i) Sample of stone is broken into pieces of about 60 mm size.
- (ii) Such pieces, weighing 5 kg, are put in both the cylinders of Deva's attrition test machine. Diameter and length of cylinder are respectively 20 cm and 34 cm.
- (iii) Cylinders are closed. Their axes make an angle of  $30^\circ$  with the horizontal.
- (iv) Cylinders are rotated about horizontal axis for 5 hours at the rate of 30 R.P.M.
- (v) After this period, the contents are taken out from the cylinders and they are passed through a sieve of 1.50 mm mesh.

- (vi) Quantity of material which is retained on the sieve is weighed.
- (vii) Percentage wear is worked out as follows:

$$\text{Percentage wear} = \frac{\text{loss in weight}}{\text{initial weight}} \times 100.$$

### (3) *Crushing test:*

With the help of this test, compressive strength of stone is found out.

Sample of stone is cut into cubes of size 40 mm × 40 mm × 40 mm. Sides of cubes are finely dressed and finished. Minimum number of specimens to be tested is three. Such specimens should be placed in water for about 24 hours prior to test.

Load-bearing surface is then covered with plaster of Paris or 5 mm thick plywood. Load is applied axially on the cube in a crushing test machine. Rate of loading is 140 kg per cm<sup>2</sup> per minute. Crushing strength of the stone is the load at which its sample crushes or fails.

### (4) *Crystallisation test:*

In this test, at least four cubes of stone with side as 40 mm are taken. They are dried for 72 hours and weighed. They are then immersed in 14% solution of Na<sub>2</sub>SO<sub>4</sub> for 2 hours. They are dried at 100°C and weighed. Difference in weight is noted. This procedure of drying, weighing, immersing and reweighing is repeated at least five times. Each time, change in weight is noted and it is expressed as a percentage of original weight.

It is to be noted that crystallisation of CaSO<sub>4</sub> in pores of stone causes decay of stone due to weathering. But, as CaSO<sub>4</sub> has low solubility in water, it is not adopted in this test.

### (5) *Freezing and thawing test:*

Specimen of stone is kept immersed in water for 24 hours. It is then placed in a freezing mixture at -12°C for 24 hours. It is then thawed or warmed at atmospheric

temperature. This should be done in shade to prevent any effect due to wind, sun rays, rain, etc. Such a procedure is repeated several times and behaviour of stone is carefully observed.

**(6) Hardness test:**

To determine the hardness of a stone, test is carried out as follows:

- (i) A cylinder of diameter 25 mm and height 25 mm is taken out from the sample of stone.
- (ii) It is weighed.
- (iii) It is placed in Dorry's testing machine and pressed with a pressure of 1250 gm.
- (iv) Annular steel disc of machine is then rotated at a speed of 28 R.P.M.
- (v) During the rotation of disc, coarse sand of standard specification is sprinkled on the top of disc.
- (vi) After 1000 revolutions, specimen is taken out and weighed.
- (vii) Coefficient of hardness is found out from the following equation:

$$\text{Coefficient of hardness} = 20 - \frac{\text{loss in weight in gm.}}{3}$$

**(7) Impact test:**

To determine toughness of a stone, impact test is carried out in page impact machine as follows:

- (i) A cylinder of diameter 25 mm and height 25 mm is taken out from the sample of stone.
- (ii) It is placed on cast-iron anvil of machine.
- (iii) A steel hammer of weight 2 kg is allowed to fall axially in a vertical direction over the specimen.
- (iv) Height of first blow is 1 cm; that of second blow is 2 cm; that of third blow is 3 cm; and so on.
- (v) Blow at which specimen breaks is noted. If it is  $n$  th blow,  $n$  represents the toughness index of stone.

**(8) Microscopic test:**

In this test, sample of stone is subjected to microscopic examination. Thin sections of stone are taken and placed under the microscope to study various properties such as:

- (i) average grain size;
- (ii) existence of pores, fissures, veins and shakes;
- (iii) mineral constituents;
- (iv) nature of cementing material;
- (v) presence of any harmful substance;
- (vi) texture of stone; etc.

**(9) Smith's test:**

This test is performed to find out the presence of soluble matter in a sample of stone. Few chips or pieces of stones are taken and they are placed in a glass tube. This tube is then filled with clear water. After about an hour, the tube is vigorously stirred or shaken. Presence of earthy matter will convert the clear water into dirty water. If water remains clear, stone will be durable and free from any soluble matter.

**(10) Water absorption test:**

Following procedure is adopted for this test:

- (i) From the given sample of stone, a cube weighing about 50 gm is prepared. Its actual weight is recorded. Let it be  $W_1$  gm.
- (ii) Cube is then immersed in distilled water for a period of 24 hours.
- (iii) Cube is taken out of water and surface water is wiped off with a damp cloth.
- (iv) It is weighed again. Let its weight be  $W_2$  gm.
- (v) Cube is suspended freely in water and its weight is recorded. Let it be  $W_3$  gm.
- (vi) Water is boiled and cube is kept in boiling water for five hours.
- (vii) It is then removed and surface water is wiped off with a damp cloth. Its weight is recorded. Let it be  $W_4$  gm.

From the above data, values of the following properties of stone are obtained:

$$\left. \begin{array}{l} \text{Percentage absorption by} \\ \text{weight after 24 hours} \end{array} \right\} = \frac{W_2 - W_1}{W_1} \times 100 \dots\dots\dots (1)$$

$$\left. \begin{array}{l} \text{Percentage absorption by} \\ \text{volume after 24 hours} \end{array} \right\} = \frac{W_2 - W_1}{W_2 - W_3} \times 100 \dots\dots\dots (2)$$

(∴ volume of displaced water =  $W_2 - W_3$ )

$$\text{Percentage porosity by volume} = \frac{W_4 - W_1}{W_2 - W_3} \times 100 \dots\dots\dots (3)$$

$$\text{Density} = \frac{W_1}{W_2 - W_3} \text{ kg/m}^3 \dots\dots\dots (4)$$

$$\text{Specific gravity} = \frac{W_1}{W_2 - W_3} \dots\dots\dots (5)$$

$$\text{Saturation coefficient} = \frac{\text{water absorption}}{\text{total porosity}} = \frac{W_2 - W_1}{W_4 - W_1} \dots\dots\dots (6)$$

### Qualities of a good building stone:

Following are the qualities or requirements of a good building stone:

#### (1) *Crushing strength:*

For a good structural stone, crushing strength should be greater than 1000 kg per cm<sup>2</sup>. Values of crushing strength of some of the stones are shown in table 1-1.

**TABLE 1-1**  
**CRUSHING STRENGTH**

Rock	Stone	Crushing strength in kg/cm <sup>2</sup>
Igneous	Basalt	1500 to 1900
	Diorite	900 to 1500
	Granite	800 to 1300
	Syenite	900 to 1500
	Trap	3300 to 3800
Sedimentary	Laterite	20 to 30
	Limestone	550
	Sandstone	650
	Shale	2 to 6
Metamorphic	Gneiss	2200 to 3700
	Slate	750 to 2100

(2) *Appearance:*

Stones which are to be used for face work should be decent in appearance and they should be capable of preserving their colour uniformly for a long time.

(3) *Durability:*

A good building stone should be durable. Various factors contributing to durability of a stone are its chemical composition, texture, resistance to atmospheric and other influences, location in structure, etc. Following are the important atmospheric agencies which affect durability of a stone:

- (i) alternate conditions of heat and cold due to differences in temperature;
- (ii) alternate conditions of wetness and dryness due to rain and sunshine;
- (iii) chemical agencies such as dissolved gases in rain;
- (iv) growth of trees and creepers in joints between stones;
- (v) wind with high velocity; etc.

For making stones durable, their natural bed should be carefully noted. Stones should be so arranged in a structure that natural bed is perpendicular or nearly so to the direction of pressure.

(4) *Facility of dressing:*

Stones should be such that they can be dressed easily and economically.

(5) *Fracture:*

For a good building stone, its fracture should be sharp, even and clear.

(6) *Hardness:*

Coefficient of hardness, as worked out in hardness test, should be greater than 17 for a stone to be used in road work. If it is between 14 and 17, stone is said to be of medium hard-

ness. If it is less than 14, stone is said to be of poor hardness and such stone should not be used in road work.

(7) *Percentage wear:*

In attrition test, if wear is more than 3 per cent, stone is not satisfactory. If it is equal to 3 per cent, stone is just tolerable. For a good building stone, wear should be equal to or less than 2 per cent.

(8) *Resistance of fire:*

Minerals composing stone should be such that shape of stone is preserved when a fire occurs. Failure of stones in case of a fire is due to various reasons such as rapid rise in temperature, sudden cooling, different coefficients of linear expansions of minerals, etc. Free quartz suddenly expands at a temperature lower than  $600^{\circ}\text{C}$ . Limestone resists fire upto about  $800^{\circ}\text{C}$  and it then splits into  $\text{CaO}$  and  $\text{CO}_2$ . Sandstone with silicates as binding material can resist a fire in a better way. Argillaceous stones are poor in strength. But they can resist fire quite well.

(9) *Seasoning:*

Stones should be well seasoned before putting into use. Stones obtained freshly from a quarry contain some moisture which is known as quarry sap. Presence of this moisture makes the stone soft. Hence, freshly quarried stones are easy to work. It is, therefore, desirable to do dressing, carving, etc. when stones contain quarry sap. Stones should be dried or seasoned before they are used in structural work.

(10) *Specific gravity:*

For a good building stone, its specific gravity should be greater than 2.7 or so.

(11) *Texture:*

A good building stone should have crystalline structure. Stones with such texture are strong and durable.

(12) *Toughness index:*

In impact test, if the value of toughness index comes below 13, stone is not tough. If it comes between 13 and 19, stone

is said to be moderately tough. If it exceeds 19, toughness of stone is said to be high.

(13) *Water absorption:*

For a good stone, percentage absorption by weight after 24 hours should not exceed 0.60.

(14) *Weathering:*

A good building stone should possess better weathering qualities. It should be capable of withstanding adverse effects of various atmospheric and external agencies such as rain, frost, wind, etc.

It should, however, be remembered that one kind of stone is not suitable in all types of construction. For instance, soft stones are required for carving, light stones are required for arches and hard stones are necessary to stand high pressures. It is, therefore, necessary to study carefully the situation in which stones are to be used before any recommendation is made. Other factors which affect the selection of stone are easy availability, nearness of quarry, facility of transport, reasonable price, etc.

### **Stone quarrying:**

#### ***Definition:***

Process of taking out stones from natural rock beds is known as *quarrying*. The term *quarry* is used to indicate the exposed surface of natural rocks. Stones, thus obtained, are used for various engineering purposes. Difference between a mine and a quarry should be noted. In case of a mine, operations are carried out under the ground at great depth. In case of a quarry, operations are carried out at ground level in an exposed condition.

#### ***Site for quarry:***

Selection of site for a quarry of stones should be done after studying carefully the following aspects:

- (1) availability of tools, materials and labour for the easy and efficient working of quarry;

- (2) distance of quarry from roads, railways, sea coast, etc.;
- (3) drainage of quarry pit;
- (4) facility of carrying and conveying stones from quarry;
- (5) geological data regarding rock formations at the site;
- (6) quality of stone available from quarry;
- (7) quantity of stone likely to be obtained from quarry;
- (8) results of trial pits; etc.

***Important considerations:***

Following are the important considerations which are to be carefully paid attention to before actually starting the quarry:

(1) *Examination of rock surface:*

Exposed surface of rock bed should be carefully examined. Presence of cracks and fissures are to be noted. Planes, along which stones will easily split, should be found out to make quarrying operations quick and economical.

(2) *Lay out:*

It is necessary to prepare a complete lay out of various stages involved in quarrying operation. Faulty planning leads to failure of quarry.

(3) *Men and machines:*

There should be proper co-ordination between men and machines employed on the quarry, so as to obtain maximum advantage from them.

(4) *Removal of top surface:*

Loose soil and soft rock present at the top surface of quarry should be removed. Material obtained from top surface is unsuitable for construction work and hence, it should be rejected. Dense rocks are available at a depth which depends on the weathering qualities of a rock.

(5) *Structural stability:*

Stones should be removed from the quarry without affecting the structural stability of its sides. If proper precautions are not taken, there may be serious slips or landslides with disastrous results.

**Methods of quarrying:**

Following are the methods of quarrying:

- (1) Digging
- (2) Heating
- (3) Wedging
- (4) Blasting.

(1) *Digging:*

In this method, stones are merely excavated with the help of suitable instruments. This method is useful when soft stones occur in the form of large or small blocks.

(2) *Heating:*

In this method, top surface of rock is heated. This is usually done by placing pieces of wood over the surface and setting fire to them. Due to unequal expansion, upper layer of rock separates out. It is indicated by a dull bursting noise. Detached portion of rock is then removed by suitable instruments. This method is useful when small blocks of more or less regular shape are to be taken out from quarry. It is suitable when rock formation consists of horizontal layers of shallow depth.

(3) *Wedging:*

Steel wedge

FIG. 1-2



Steel point

FIG. 1-3

In this method, if rock surface contains cracks or fissures, steel wedges or points, as shown in fig. 1-2 and fig. 1-3 respec-

tively, are driven through such cracks by means of hammers. Blocks of stone are then shifted and they are removed with the help of suitable instruments.

If natural cracks are absent, artificial cracks are to be formed. A line of holes is drilled along the rock surface. Diameter of hole is about 12 mm. Distance between successive holes is about 10 cm to 15 cm. Depth of hole is about 20 cm to 25 cm. Plug and feathers are placed into these holes as shown in fig. 1-4. A plug is a conical steel wedge. A feather is a

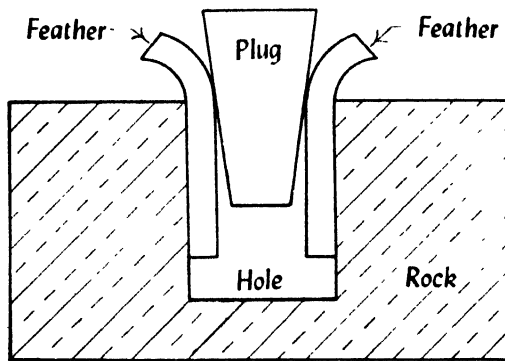

Plug and feathers

FIG. 1-4

flat steel wedge with its upper end slightly curved. A plug is placed between the feathers and all plugs are then simultaneously driven by hammer. A great force is exerted and a crack is developed along the line of holes. If stone is comparatively hard, pneumatic drill may be employed to prepare holes for plug and feathers.

If rock is comparatively soft, only wood plugs may be used. They are placed in the holes and are kept soaked in water. When wood plugs swell or expand, a great force is exerted and rock splits along the line of holes.

Wedging is adopted for rocks which are comparatively soft such as laterite, marble, limestone, sandstone, etc. Wedging is preferred to blasting, wherever possible.

#### (4) *Blasting*:

In this method, explosives are used to convert rocks into

small pieces of stones. This method is adopted for quarrying hard stones, having no fissures or cracks. Stones obtained by blasting are usually of small size and they are used as ballast in railways, aggregate for concrete, road metal, etc.

### Tools for blasting:

Following tools are required in the process of blasting:

(1) *Dipper*:

This is shown in fig. 1-5 and it is used to drill a hole to the required depth.

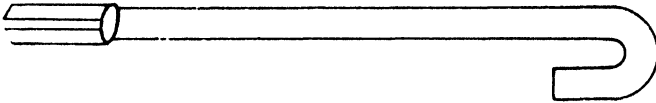

Dipper  
FIG. 1-5

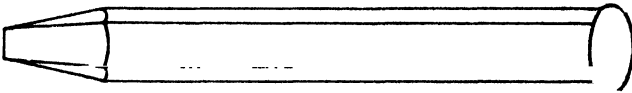

Jumper  
FIG. 1-6

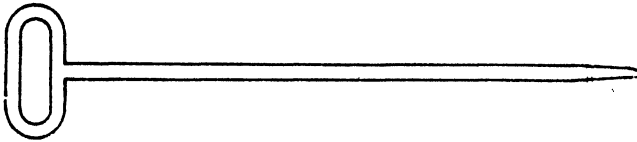

Priming needle  
FIG. 1-7

(2) *Jumper*:

This is shown in fig. 1-6 and it is used to make blast holes.

(3) *Priming needle*:

This is shown in fig. 1-7 and it is used to maintain the hole when tamping is being done.

tively, are driven through such cracks by means of hammers. Blocks of stone are then shifted and they are removed with the help of suitable instruments.

If natural cracks are absent, artificial cracks are to be formed. A line of holes is drilled along the rock surface. Diameter of hole is about 12 mm. Distance between successive holes is about 10 cm to 15 cm. Depth of hole is about 20 cm to 25 cm. Plug and feathers are placed into these holes as shown in fig. 1-4. A plug is a conical steel wedge. A feather is a

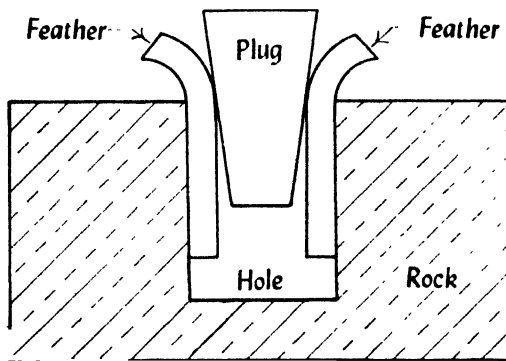

Plug and feathers

FIG. 1-4

flat steel wedge with its upper end slightly curved. A plug is placed between the feathers and all plugs are then simultaneously driven by hammer. A great force is exerted and a crack is developed along the line of holes. If stone is comparatively hard, pneumatic drill may be employed to prepare holes for plug and feathers.

If rock is comparatively soft, only wood plugs may be used. They are placed in the holes and are kept soaked in water. When wood plugs swell or expand, a great force is exerted and rock splits along the line of holes.

Wedging is adopted for rocks which are comparatively soft such as laterite, marble, limestone, sandstone, etc. Wedging is preferred to blasting, wherever possible.

#### (4) *Blasting*:

In this method, explosives are used to convert rocks into

small pieces of stones. This method is adopted for quarrying hard stones, having no fissures or cracks. Stones obtained by blasting are usually of small size and they are used as ballast in railways, aggregate for concrete, road metal, etc.

### Tools for blasting:

Following tools are required in the process of blasting:

(1) *Dipper*:

This is shown in fig. 1-5 and it is used to drill a hole to the required depth.

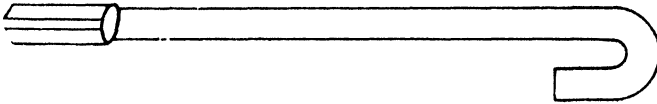

Dipper  
FIG. 1-5

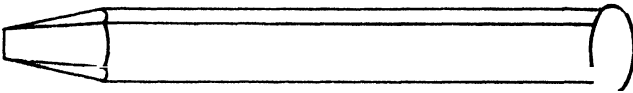

Jumper  
FIG. 1-6

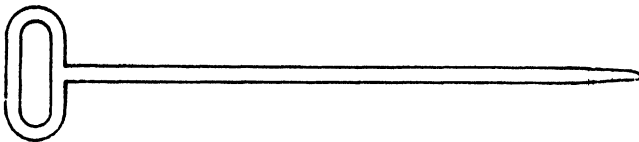

Priming needle  
FIG. 1-7

(2) *Jumper*:

This is shown in fig. 1-6 and it is used to make blast holes.

(3) *Priming needle*:

This is shown in fig. 1-7 and it is used to maintain the hole when tamping is being done.

(4) *Scraping spoon* :

This is shown in fig. 1-8 and it is used to scrap or remove dust from blast holes.

(5) *Tamping bar* :

This is shown in fig. 1-9 and it is used to ram or tamp the material while refilling blast holes.



Scraping spoon  
FIG. 1-8

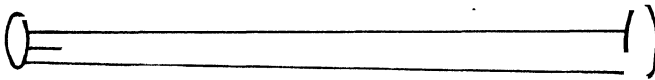

Tamping bar  
FIG. 1-9

### Materials for blasting:

Following materials are required in the process of blasting:

(1) *Detonators* :

A detonator is a contrivance whose explosion initiates that of another. It is in the form of a copper cylinder having diameter and length as 6 mm and 25 mm respectively. It is closed at one end. It contains 6 to 9 grains of fulminate of mercury. It is used when dynamite is adopted as explosive. Detonators are fired either by fuse or electric spark.

(2) *Explosives* :

Blasting powder and dynamite are commonly used as explosives. Blasting powder is also known as *gun powder* and it is a mechanical mixture of charcoal, saltpetre ( $\text{KNO}_3$ ) and sulphur. The proportions of charcoal, saltpetre and sulphur by weight are 15, 75 and 10 respectively. Sometimes, saltpetre is substituted by chile saltpetre ( $\text{NaNO}_3$ ) in the

composition of blasting powder. But as chile saltpetre absorbs moisture, it is difficult to keep such powder for a long lime.

Dynamite consists of 25 per cent of sandy earth saturated with 75 per cent of nitro-glycerine. It is in the form of thick paste and it is sold in cartridges. Table 1-2 shows the comparison of blasting powder and dynamite.

**TABLE 1-2**  
COMPARISON OF BLASTING POWDER AND DYNAMITE

Sr.No.	Item	Blasting powder	Dynamite
1.	Action in quarrying.	Large blocks of stones are obtained. Its lifting power is high.	Small blocks of stones are obtained. Its shattering power is high.
2.	Cost	Cheap	Its cost is about five times than that of blasting powder.
3.	Destructive power	Weak	Very strong -- about six times than that of blasting powder.
4.	Efficiency	1 kg of blasting powder will loosen about 4 m <sup>3</sup> of rock.	1 kg of dynamite will loosen about 6 m <sup>3</sup> of rock.
5.	Tamping	It requires hard tamping.	As it is in the form of a thick paste, it does not require hard tamping.
6.	Use	It is used for ordinary type of quarrying work.	It is used for tunnelling and mining operations. It can also be adopted for quarrying under water.

Other explosives which are used in blasting are given in table 1-3.

**TABLE 1-3**  
EXPLOSIVES IN BLASTING

Sr.No.	Name of explosive	Composition	Remarks
1.	Blasting gelatine	It consists of 93% of nitro-glycerine and 7% of gun cotton.	It has high explosive power about 50% more than that of dynamite.
2.	Cordite	It is prepared from nitro-glycerine.	It is a powerful explosive and it does not produce smoke. It can be used under water.

Sr.No.	Name of explosive	Composition	Remarks
3.	Gelignite	It consists of 65% blasting gelatine and 35% of absorbing powder.	It is more convenient than dynamite. It is a powerful explosive and can be used under water.
4.	Gun cotton	Clean cotton is saturated in a cool mixture of nitric acid ( $\text{HNO}_3$ ) and sulphuric acid ( $\text{H}_2\text{SO}_4$ ). It is pressed into blocks or sticks while it is wet.	It is as strong as dynamite. But its shattering power is less. It decomposes with rise of temperature. It is generally transported and stored in moist condition.
5.	Liquid oxygen	It is oxygen in liquid state.	It is stored in special containers. It is comparatively cheaper. It is used for blasting on a large scale, for mining operations, for blasting under water, etc.
6.	Rock-a-rock	It consists of 79% of potassium chlorate ( $\text{KClO}_3$ ) and 21% of nitro-benzol.	Its action under water is more effective. It is used in U.S.A.

### (3) *Fuses:*

These are required to ignite the explosives. They are in the form of a small rope of cotton with a core of continuous thread of fine gun powder. Rate of burning of a good fuse is about 1 cm per second. For electric firing, patented electrical fuses are used.

### **Process of blasting:**

Blasting is carried out as follows:

- (i) Blast holes of required depths are made with jumpers, dippers and scraping spoons. Small quantity of water is added at intervals to make the rock soft and to convert dust into paste. Such paste is easily removed by scraping spoons.
- (ii) Blast holes are cleaned. They are made dry by rotating a small iron rod with a rag tied at its end.
- (iii) Charge of gun powder or dynamite is placed at the bottom of hole. A priming needle which is a thin copper rod is placed in position. It is to be coated with grease so as to make its withdrawal easy.

- (iv) Remaining portion of blast hole is filled with damp clay or powdered stone. It is to be rammed hard. Ramming is done by a copper tamping bar. When tamping is being done, priming needle is frequently turned so that it can be easily removed when the hole is completely filled up.
- (v) Priming needle is taken out and the space formed by it is filled with gun powder or dynamite as shown in fig. 1-10.

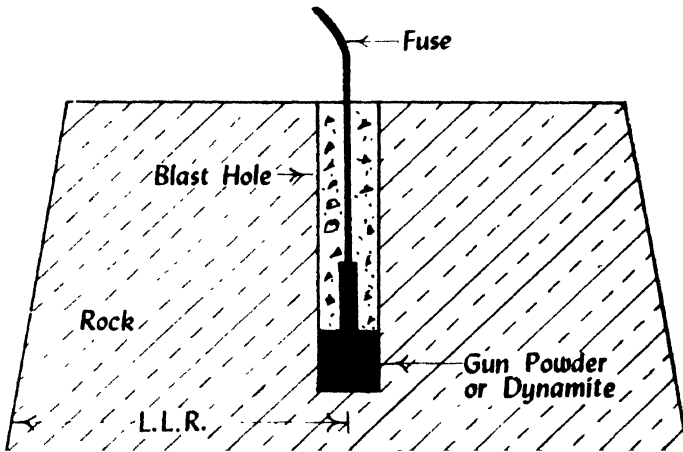

Process of blasting

FIG. 1-10

- (vi) A fuse is inserted in the hole and it is kept projecting about 15 cm to 20 cm above rock surface. Thus a link is formed between the fuse at top and charge of explosive at the bottom. Detonators are used when explosive is dynamite.
- (vii) Free end of the fuse is fired. This can be done either with a match or with electricity. Firing by electricity has the following *advantages*:
- It ensures safety.
  - It results in saving of time and labour.
  - Firing is simultaneous and hence, efficiency of explosives is greatly increased.
  - It is useful for firing fuse under water.

- (viii) Explosion takes place and rock is disintegrated into small blocks. Such blocks are collected and taken for further treatment.

### **Precautions in blasting:**

Following precautions are to be taken in the process of blasting to avoid occurrence of serious accidents:

(1) *Failure of explosion:*

Sometimes a charge fails to explode due to any reason. In such a case, a fresh blast hole is made near the hole that has failed and the process of blasting is repeated. Fresh blast hole should not be too near the failed hole. In many cases, explosion of fresh blast hole will also explode the charge of failed blast hole and in such a case, it may result into a serious accident.

(2) *Line of least resistance:*

Rocks contain fissures, cracks or bedding planes. When explosion occurs, gases are formed. If blast hole is tamped sufficiently hard, it will not be possible for gases to come out through blast hole. In such a case, gases will follow the line of path which offers least resistance. Such a line is known as *line of least resistance* or L.L.R. In practice, L.L.R. is taken as the shortest distance between the centre of charge and nearest rock surface, as shown in fig. 1-10. Length of L.L.R. plays an important part in determining the quantity of explosive required in the process of blasting and hence, it should be carefully decided.

(3) *Needle and tamper:*

These should be made of copper, brass or bronze and not of steel. A spark is formed when steel strikes the rock. Hence, if they are of steel, premature explosion will take place and it may result into a serious accident.

(4) *Notice of blasting:*

Nobody should be allowed to enter the area where blasting is being done. Notices and visible signs such as red flags should be placed at suitable places along the periphery of such area.

(5) *Retreat to a safe distance:*

Fuse adopted should be such that a worker can retreat to a safe distance after firing it. For large scale work, whistles or sirens may be used to warn the workers to go to a safe place before explosion takes place.

(6) *Seepage of water:*

If water is entering the blast hole, charge of explosive should be placed in thin iron plate or in waterproof paper.

(7) *Skilled supervision:*

Work of blasting should be entrusted only to trained and experienced persons.

(8) *Storing:*

Explosives should be stored very carefully. They should be placed in specially constructed magazine or store-house. It should be away from residential buildings and important structures. Different explosives should be placed in separate boxes. Detonators should be kept entirely away from other explosives.

### **Machines for quarrying:**

Machines are required in quarrying operations for the following purposes:

- (1) to cut stones in required sizes;
- (2) to dress stones;
- (3) to form channels in rock;
- (4) to lift large blocks of stones;
- (5) to polish the stone surfaces;
- (6) to prepare blast holes;
- (7) to screen the material according to size and grade;
- (8) to transport the material from quarry at suitable place; etc.

A list of machines commonly employed in quarrying is given in table 1-4.

**TABLE 1-4**  
**MACHINES FOR QUARRYING**

Sr. No.	Name of machine	Use
1.	Cableways and ropeways	To hoist and transport stones.
2.	Channellers	To form long narrow channels in the rock so as to take out massive blocks of stones.
3.	Crushers	To break large stones into small sizes.
4.	Drilling machines	To drill blast holes.
5.	Moulding machines	To form mouldings on stones.
6.	Polishing machines	To polish the surface of stones.
7.	Pulley blocks and cranes	To lift stones.
8.	Saws	To cut stones into desired shapes and sizes.
9.	Screens	To sort out stones according to sizes and grades.
10.	Tipping wagons, cars, dumpers, etc.	To transport the materials from quarry.

### **Dressing of stones:**

Stones, after being quarried, are to be cut into suitable sizes and with suitable surfaces. This process is known as *dressing of stones* and it is carried out for the following purposes:

- (1) to get the desired appearance from stone work,
- (2) to make the transport from quarry easy and economical,
- (3) to suit to the requirements of stone masonry,
- (4) to take advantage of local men near quarry who are trained for such type of work, etc.

With respect to the place of work, dressing can be divided into *two* types, namely, quarry dressing and site dressing. At the quarry place, the stones are roughly dressed to secure the following *advantages*:

- (1) At quarry site, it is possible to get cheap labour for the process of dressing of stones.
- (2) It is possible to sort out stones for different works, if quarry dressing is practised.
- (3) The irregular and rough portions of the stones are removed which decrease the weight of stones and it also facilitates easy transportation of the stones.
- (4) The natural bed surface of stones can be made prominent during the quarry dressing.

- (5) The stones when freshly quarried contain quarry sap and hence, they are comparatively soft and can be easily dressed.

Following are the varieties of finishes obtained by dressing of stones:

(1) ***Axed finish:***

Surfaces of hard stones such as granite are dressed by means of an axe. Such a finish is termed as an axed finish.

(2) ***Boasted or droved finish:***

In this type of finish, boaster is used to make non-continuous parallel marks on the stone surface as shown in fig. 1-11. These marks may be horizontal, inclined or vertical. A boaster is a chisel having an edge of width about 60 mm.

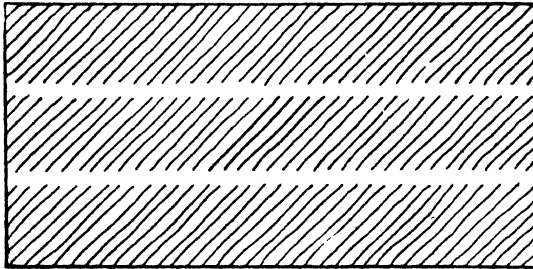

Boasted finish

FIG. 1-11

(3) ***Chisel-draughted margins:***

In order to obtain uniform joints in stone work, margins are placed which may be either squared or pitched or chamfered.

(4) ***Circular finish:***

In this type of finish, surface of stone is made round or circular as in case of a column.

(5) ***Dragged or combed finish:***

In this type of finish, a drag or a comb, which is a piece of steel with a number of teeth, is rubbed on the surface in

all directions and surface, as shown in fig. 1-12, is obtained. This finish is suitable for soft stones only.

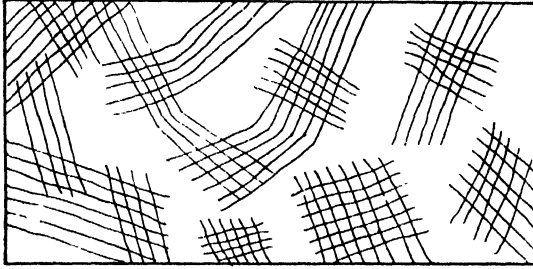

Dragged finish  
FIG. 1-12

(6) ***Furrowed finish:***

In this type of finish, a margin of about 20 mm width, is sunk on all the edges of stone and the central portion is made to project about 15 mm. A number of vertical or horizontal grooves about 10 mm wide are formed in this projected portion as shown in fig. 1-13. This finish is generally adopted to make the quoins prominent.

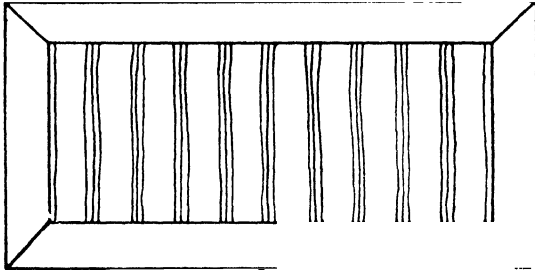

Furrowed finish  
FIG. 1-13

(7) ***Moulded finish:***

Surface of the stone can be moulded in any desired shape so as to improve the appearance of the work. Mouldings can be made either by hand or machine.

(8) ***Hammer-dressed finish:***

In this type of finish, stones are made roughly square or rectangular by means of a waller's hammer as shown in fig. 1-14.

**(9) Plain finish:**

In this type of finish, surface of the stone is made approximately smooth with a saw or with a chisel.

**(10) Polished finish:**

Surface of the stones such as marbles, granites, etc. can be polished either with hand or with machine.

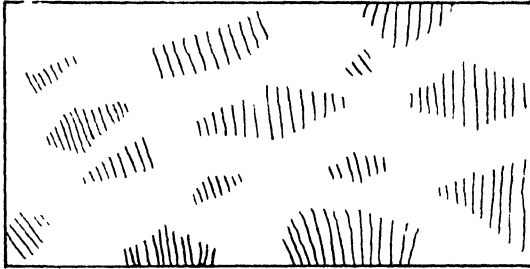

Hammer-dressed finish

FIG. 1-14

**(11) Punched machine:**

On the stone surface, depressions are made by using a punch. Surface of the stone takes the form of a series of hollows and ridges.

**(12) Rubbed finish:**

This type of finish is obtained by rubbing a piece of stone with the surface or by rubbing the surface with the help of a suitable machine. Water and sand are freely used to accelerate the process of rubbing.

**(13) Scabbling finish:**

In this type of finish, irregular projections are removed with a scabbling hammer and in this way, stones are roughly dressed.

**(14) Reticulated finish:**

This type of finish presents a net-like appearance as shown in fig. 1-15. A margin, about 20 mm wide, is marked on the edges of stone and irregular sinkings are made on the enclosed space. A margin, about 10 mm wide, is provided around the irregularly shaped sinkings, having a depth of

about 5 mm. A pointed tool is used to put the marks on the sunk surface so as to present a pock-marked appearance.

**(15) *Tooled finish:***

Stone surface is finished by means of a chisel and parallel continuous marks, either horizontal or inclined or vertical, are left on the surface as shown in fig. 1-16.

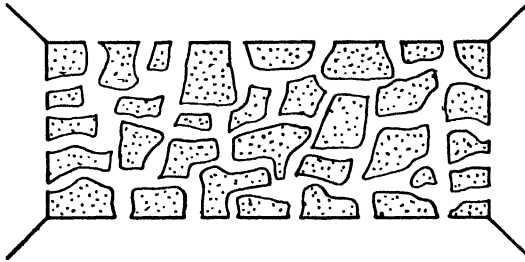

Reticulated finish

FIG. 1-15

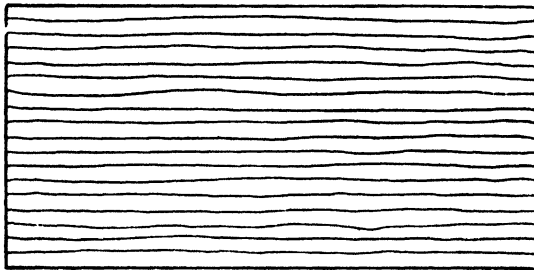

Tooled finish

FIG. 1-16

**(16) *Self-faced or rock-faced or quarry-faced finish:***

Some stones, as obtained from the quarry, possess smooth surface and they can be directly placed on the work. Such a stone surface is termed as self-faced or rock-faced or quarry-faced finish.

**(17) *Sunk finish:***

This finish is obtained by sinking the surface below the original level in the form of wide grooves, chamfers, inclined surfaces, etc.

**(18) *Vermiculated finish:***

This finish is just similar to reticulated type except that the sinkings are more curved. This finish presents a worm-caten appearance.

**Deterioration of stones:**

Stones with exposed faces are acted upon by various atmospheric and external agencies so as to cause their deterioration. Following are the causes of decay of stones:

- (1) Alternate wetness and drying
- (2) Frost
- (3) Impurities in atmosphere
- (4) Living organisms
- (5) Movements of chemicals
- (6) Rain water
- (7) Temperature variations
- (8) Vegetable growth
- (9) Wind.

**(1) *Alternate wetness and drying:***

Stones are made wet by various agencies such as rain, frost, dew, etc. Such wet surface is dried by sunshine. It is found that stones subjected to such alternate wetness and drying wear out quickly.

**(2) *Frost:***

In hill stations or very cold places, moisture present in the atmosphere is deposited in pores of stones. At freezing point, this moisture freezes and in doing so, it expands in volume and causes the splitting of stone.

**(3) *Impurities in atmosphere:***

Atmosphere contains various impurities which have adverse effects on stones. For instance, acids and fumes are predominant in an industrial town. These impurities act on carbonate of lime and cause the deterioration of stone.

**(4) *Living organisms:***

Some living organisms like worms and bacteria act upon stones and deteriorate them.

(5) *Movements of chemicals:*

If stones of different variety, such as limestone and sandstone, are used side by side in the same structure, chemicals formed by the action of atmospheric agencies on one variety may move on the other and cause the deterioration of that other.

(6) *Rain water:*

Action of rain water on stones is two fold — physical and chemical. Rain wets the surface of stone and it is dried by sunshine. Such alternate wetness and drying results in the disintegration of stone. This is the physical action of rain water.

Rain water, as it descends through the atmosphere to the surface of earth, absorbs carbon dioxide ( $\text{CO}_2$ ), hydrogen sulphide ( $\text{H}_2\text{S}$ ) and other gases present in the atmosphere. These gases act adversely on stones and they cause decay of stones. This is the chemical action of rain water.

(7) *Temperature variations:*

Rise of temperature results in expansion of stones. Fall of temperature causes contraction of stones. If rise and fall of temperatures are frequent, stones are easily deteriorated.

(8) *Vegetable growth:*

Certain trees and creepers develop on stone surface with their roots in joints between stones. Such roots attract moisture and keep the stone surface damp. At the same time, they try to expand. Such actions then accelerate the decay of stones.

(9) *Wind:*

Wind contains fine particles of dust. If it is blowing with high velocity, such particles will strike against the stone surface and thus stones will be decayed. Wind also allows rain water to enter pores of stones with force. Such water, on freezing, expands and splits the stones.

**Preservation of stones:**

Decay of building stones of inferior quality, is to some extent, prevented, if they are properly preserved. For this

purpose, preservatives are applied on the stone surfaces. An ideal preservative has the following properties:

- (1) It does not allow moisture to penetrate the stone surface.
- (2) It does not develop objectionable colour.
- (3) It hardens sufficiently so as to resist effects due to various atmospheric agents.
- (4) It is easily penetrated in stone surface.
- (5) It is economical.
- (6) It is non-corrosive and harmless.
- (7) It remains effective for a long time after drying.
- (8) Its application on stone surface is easy.

It should, however, be remembered that there is not a single preservative which is suitable for all types of stones. Choice of a preservative, therefore, requires careful consideration. Depending upon the chemical composition of stones and their location in structure, a particular preservative should be recommended. Each case should be properly studied before a final choice is made.

Following are the preservatives which are commonly adopted to preserve stones:

**(1) Coal tar:**

If coal tar is applied on stone surface, it preserves stone. But colour of coal tar produces objectionable appearance and surface coated with coal tar absorbs heat of the sun. Hence, this preservative is not generally adopted.

**(2) Linseed oil:**

This preservative may be used either as raw linseed oil or boiled linseed oil. Raw linseed oil does not disturb the original shade of stone. But it requires frequent renewal, usually once in a year. Boiled linseed oil lasts for a long period. But it makes the stone surface dark.

**(3) Paint:**

An application of paint on stone surface serves as a preservative. Paint changes the original colour of stone. It is applied under pressure, if deep penetration is required.

**(4) Paraffin:**

This preservative may be used alone or it may be dissolved in naphtha and then applied on stone surface. It changes the original colour of stone.

**(5) Solution of alum and soap:**

Alum and soft soap are taken in proportion of about 75 gm and 50 gm respectively and they are dissolved in a litre of water. This solution, when applied on stone surface, acts as a preservative.

**(6) Solution of baryta:**

A solution of barium hydroxide  $\text{Ba}(\text{OH})_2$ , when applied on stone surface, acts as a preservative. This preservative is used when decay of stone is mainly due to calcium sulphate,  $\text{CaSO}_4$ . Following chemical reaction takes place:

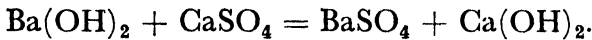

Barium sulphate is insoluble and it is least affected by atmospheric agencies. Calcium hydroxide absorbs carbon dioxide from atmosphere and forms calcium carbonate  $\text{CaCO}_3$  which adds to the strength of stone.

**Artificial stones:**

These are also known as *cast stones* or *reconstructed stones*. Following procedure is generally adopted in making an artificial stone:

- (1) Natural stone is crushed into sizes less than 6 mm.
- (2) Stone dust is removed.
- (3) A mixture of  $1\frac{1}{2}$  parts of stones of size 3 mm to 6 mm,  $1\frac{1}{2}$  parts of stones of size less than 3 mm and 1 part of cement by volume is prepared.
- (4) Necessary pigment to produce the desired colour effect is added to the above mixture. Its proportion should not exceed 15 per cent of cement by weight.
- (5) Water in required quantity is added and thorough mixing of materials is done.
- (6) Mixture thus prepared is transferred to specially constructed moulds.

- (7) It is allowed to harden and its surface is kept wet. Artificial stone is then ready in block form.
- (8) Polishing is done, if required.
- (9) White cement may be used in place of ordinary cement to produce colour of light shade.

### ***Forms of artificial stones:***

Artificial stones may take up various forms as follows:

#### (1) *Cement concrete:*

This is a mixture of cement, fine aggregate, coarse aggregate and water. It may be cast-in-situ or pre-cast. It is widely used at present. If steel is used with cement concrete, it is known as reinforced cement concrete construction or R.C.C.

#### (2) *Mosaic tiles:*

Pre-cast concrete tiles with marble chips at top surface are known as mosaic tiles. They are available in different shades and are widely adopted at present.

#### (3) *Terrazo:*

This is a mixture of marble chips and cement. It is used for bath rooms, residential buildings, temples, etc.

### ***Advantages of artificial stones:***

Following are the *advantages* of artificial stones:

- (1) Cavities may be kept in artificial stones. These cavities are used to convey pipes, electric wires, etc.
- (2) Grooves can be kept in an artificial stone, while it is being casted. These grooves are useful for fixing various fittings.
- (3) It can be cast in desired shape.
- (4) It can be made in a single piece and hence, trouble of getting large blocks of stones for lintels, beams, etc. is avoided.
- (5) It can be made stonger than natural stone.
- (6) It is cheap and economical as stones of smaller sizes are profitably consumed.
- (7) It is more durable than natural stone.

### Common building stones of India:

Table 1-5 shows the list of building stones which are commonly used in India together with their classification, qualities, uses and localities.

TABLE 1-5  
COMMON BUILDING STONES OF INDIA

Sr. No.	Stone	Classification	Qualities	Uses	Localities
1.	Basalt and trap	Igneous	Hard and tough; difficult to work. Its sp. gr. is 3 and compressive strength varies from 1530 to 1890 kg./cm <sup>2</sup> .	Road metal, for rubble masonry, foundation work, etc.	Maharashtra, Bihar. Gujarat. Bengal and M.P.
2.	Chalk	Sedimentary	Pure white limestone; soft and easy to form powder.	In preparing glazier's putty; as colouring material in manufacture of portland cement.	Same as limestone.
3.	Gneiss	Metamorphic	Splits into thin slabs; easy to work. Its sp. gr. is 2.69 and compressive strength is 2100 kg./cm <sup>2</sup> .	Street paving, rough stone masonry work, etc.	Madras, Mysore, Bihar, A.P., Maharashtra, Bengal, Kerala and Gujarat.
4.	Granite	Igneous	Hard, durable and available in different colours, highly resistant to natural forces, can take nice polish. Its sp. gr. varies from 2.6 to 2.7 and compressive strength varies from 770 to 1300 kg/cm <sup>2</sup> .	Steps, sills, facing work, walls, bridge piers, columns, road metal, ballast, etc. It is unsuitable for carving.	Kashmir, Madras, Punjab, Rajasthan, U.P., M.P., Mysore, Maharashtra. Assam, Bengal, Bihar, Orissa, Kerala and Gujarat.
5.	Kankar	Sedimentary	Impure limestone.	Road metal, manufacture of hydraulic lime, etc.	North and Central India.

6. Laterite	Metamorphic	Porous and spongy structure; easily quarried in blocks; contains high percentage of oxide of iron; available in different colours. Its compressive strength varies from 18 to 32 kg/cm <sup>2</sup> .	Building stone, road metal, rough stone masonry work, etc.	Bihar, Orissa, Mysore, M.P., Maharashtra, Kerala, A.P. and Madras.
7. Limestone	Sedimentary	Consists of carbonate of lime; easy to work. Its sp. gr. varies from 2.00 to 2.75 and compressive strength is 550 kg/cm <sup>2</sup> .	Floors, steps, walls, road metal, manufacture of lime in blast furnaces, etc.	Maharashtra, Rajasthan, Punjab, Gujarat, Andaman Islands, Bengal, Bihar, A.P., Himachal Pradesh, M.P. and U.P.
8. Marble	Metamorphic	Can take good polish and available in different colours. Its sp. gr. is 2.65 and compressive strength is 720 kg/cm <sup>2</sup> .	Flooring, facing work, columns, steps, ornamental work, etc. It can take nice polish. It can easily be sawn and carved.	Rajasthan, Maharashtra, Gujarat, A.P., Mysore, M.P. and U.P.
9. Murum	Metamorphic	Decomposed laterite, deep brown or red in colour.	Blindage for metal roads, for fancy paths and garden walls.	Same as Laterite.
10. Quartzite	Metamorphic	Hard, brittle, crystalline and compact; difficult to work and dress.	Retaining walls, road metal, concrete aggregate, pitching, rubble masonry, facing of buildings, etc.	Bengal, A.P., Himachal Pradesh, Madras, U.P., Mysore, Gujarat, Punjab and Rajasthan.
11. Sandstone	Sedimentary	Consists of quartz and other minerals, easy to work and dress and available in different colours. Its sp. gr. varies from 2.65 to 2.95 and compressive strength is 650 kg/cm <sup>2</sup> .	Steps, facing work, columns, flooring, walls, road metal, ornamental carving, etc.	A.P., M.P., Punjab, Rajasthan, Maharashtra, Gujarat, Andaman Islands, Bengal, Bihar, Himachal Pradesh, Kashmir, Madras and U.P.
12. Slate	Metamorphic	Black colour and splits along natural bedding planes; non-absorbent. Its sp. gr. is 2.89 and compressive strength varies from 770 to 2110 kg/cm <sup>2</sup> .	Roofing work, sills, damp proof courses, etc.	U.P., M.P., Bihar, Madras, Rajasthan and Mysore.

**QUESTIONS**

1. Discuss geological classification of rocks.
2. How are rocks physically and chemically classified?
3. What are rock forming minerals?
4. What is texture of a rock? Enumerate its various types.
5. Write short notes on:
  - (1) Sources of stones
  - (2) Microscopic test
  - (3) Crushing test
  - (4) Acid test
  - (5) Tools for blasting
  - (6) Silicious rocks
  - (7) Argillaceous rocks
  - (8) Detonators.
6. What is fracture of a rock? Mention its different types.
7. What are various uses of stones?
8. Define natural bed of a stone and discuss its importance.
9. Explain how the following tests for stones are carried out:
  - (1) Attrition test
  - (2) Hardness test
  - (3) Impact test
  - (4) Water absorption test
  - (5) Smith's test.
10. What are the qualities of a good building stone? Discuss them.
11. Define a quarry and mention the factors to be considered while making a selection for its site.
12. What are the important considerations which are to be carefully paid attention to before actually starting the quarry?
13. Describe the methods of quarrying.
14. What are the materials required in the process of blasting?
15. Give a list of explosives used in blasting. Compare blasting powder with dynamite.
16. Describe the process of blasting.
17. What are the precautions to be taken in the process of blasting?

18. Why are machines required in quarrying? Give a list of machines which are commonly employed in quarrying operations.
19. What is meant by dressing of a stone? Describe its various varieties.
20. What are the advantages of quarry dressing?
21. Give sketches of the following:
  - (1) Steel point
  - (2) Jumper
  - (3) Tamping bar
  - (4) Dragged finish
  - (5) Reticulated finish
  - (6) Boasted finish.
22. What are various atmospheric and external agencies which are responsible for the deterioration of stones?
23. What are the qualities of an ideal preservative? Mention the preservatives which are commonly used.
24. How is artificial stone prepared? What are its different forms?
25. Mention the advantages of artificial stones.
26. Give classification, qualities, uses and localities where they are available in India of the following stones:  
Granite; Limestone; Marble; Sandstone; Slate; Laterite; Quartzite.
27. Distinguish between the following:
  - (1) Igneous rocks and sedimentary rocks
  - (2) Quarry and mine
  - (3) Stratified rocks and foliated rocks
  - (4) Texture of a rock and fracture of a rock
  - (5) Natural stone and artificial stone
  - (6) Laterite and murum
  - (7) Limestone and kankar.
  - (8) Monomineralic rocks and polymineralic rocks.
28. Give reasons for the following:
  - (1) Volcanic rocks are extremely fine grained in structure.
  - (2) The direction of natural bed should be perpendicular or nearly so to the direction of pressure.
  - (3) Freshly quarried stones are easy to work.
  - (4) Stones should be removed from quarry without affecting the structural stability of its sides.
  - (5) Fresh blast hole should not be too near the failed hole.
  - (6) The industry of buildings material plays a vital role in our national economy.

# Chapter 2

## CLAY PRODUCTS AND REFRACTORIES

### Ceramics:

The term *ceramics* is used to indicate the potter's art or articles made by the potter. It is derived from Greek word *keramos* meaning *potter's earth*. The ceramic products are broadly divided into the following *three* categories:

- I. Clay products
- II. Refractories
- III. Glass.

In this chapter, clay products and refractories will be discussed and glass will be discussed in chapter XII.

### I. Clay products:

Clay occurs plenty in nature. Clay is a distinct product of chemical weathering of igneous rocks. Felspar is predominant in igneous rocks. One of the variety of felspar is orthoclase felspar. It is whitish, greyish or pinkish in colour. Rocks disintegrate easily, if orthoclase felspar is in abundance in their structure. Thus, orthoclase felspar is mainly responsible for the production of clays in nature. This mineral, on decomposition, gives kaolinite which is free from iron oxide and alkalis. The term kaolin is used to indicate the product having composition of pure kaolinite. In kaolin, alumina and silica compounds are held in a colloidal state and these compounds form the basic constituents of all clays. In addition to these compounds, various other materials such as silicates of calcium and magnesium, iron oxide, free sand, sodium, manganese, chromium, etc. also occur in clays in small proportions.

Clay, when made wet with water, possesses a high degree of tenacity and plasticity. Such plastic clay can be moulded in desired shapes. It is then dried and burnt. Clay contains water in *two* forms, namely, (i) free water and (ii) combined water. Free water is removed during drying. To remove

chemically combined water, clay is heated to a high temperature. At this stage, chemical changes occur among the constituents of clay and new products are formed which are hard and compact. Beyond a certain limit of temperature, clay becomes soft and products lose their shapes. This limit of temperature will depend on the quality of clay.

Clay products which are employed in building industry are tiles, terra-cotta, earthenwares, stonewares, porcelain and bricks. All these products, except bricks, will be dealt with in this chapter. Bricks will be discussed in the next chapter. Process of glazing will also be described in this chapter.

### **Tiles:**

Tiles are used for various purposes in building industry. They are thinner than bricks and hence, should be carefully handled to avoid any damage to them.

### ***Manufacture of tiles:***

Following *four* distinct operations are involved in the general process of manufacturing tiles:

- (1) Preparation of clay
- (2) Moulding
- (3) Drying
- (4) Burning.

Each operation will now be briefly treated.

#### (1) *Preparation of clay:*

The selected clay is taken and it is made free from any impurity such as grit, pebbles, etc.. Such clay is then pressed and converted into fine powder in pug mills. For tiles of superior quality, a large quantity of pure water is added to the powdered clay and it is well mixed in a tank. Mixture is then allowed to stand quietly. Coarse heavy particles settle at the bottom of tank. Fine particles are taken into other tanks and water is then allowed to dry off. Fine clay left after such process is used for the manufacture of tiles. To make the tiles hard and impervious, a mixture of ground glass and potteryware may be added in required quantity to clay of tiles.

(2) *Moulding:*

Clay is placed in moulds which represent the pattern or shape in which tile is to be formed. Moulding may be done either with the help of wooden moulds or mechanical means or potter's wheel. Wooden moulds should be prepared from well seasoned timber. Clay is pressed into such moulds and tiles are ready for drying when clay is taken out of moulds. Care should be taken to preserve the shape of tiles during the removal of moulds. Moulding with the help of mechanical means includes the provision of machines and clay is pressed into such machines to get tiles of desired section and shapes. Method of moulding by potter's wheel is similar to one that is adopted by a potter in the manufacture of earthenware vessels. This method is adopted when tile is of circular shape when on the wheel. It may, however, have diameter varying along its length.

(3) *Drying:*

Tiles, as they come out of moulds, are placed flat one above the other in suitable number. Different heaps are thus formed. After about 2 days, the irregularity of tiles due to warping is corrected with a flat wooden mallet. Tiles are then lifted as they have by now become hand-hard. Edges and under surfaces are cleaned. They are stacked on edge under a shade to dry for about two days or so. Drying under a shade prevents warping and cracking of tiles due to rain and sun.

(4) *Burning:*

Tiles are then burnt in kilns. A typical kiln for accommodating about 30000 to 40000 tiles is shown in fig. 2-1. It is circular in shape and is protected by a shed. A layer of bricks is laid flat on the rows of long, narrow flues. Burning is affected by firing wood placed in these flues. Bricks are arranged in such a way that open spaces are left in between them. Above the layer of bricks, dried tiles are placed on edge layer by layer. Closing of doorways is effected by brickwork in mud. Top of kiln is covered with a layer of old tiles placed in a loose condition.

Regulation of heat is important to achieve better results. Fire is gentle in the beginning. It removes moisture. It is then raised to about  $800^{\circ}\text{C}$ . It is slackened for a

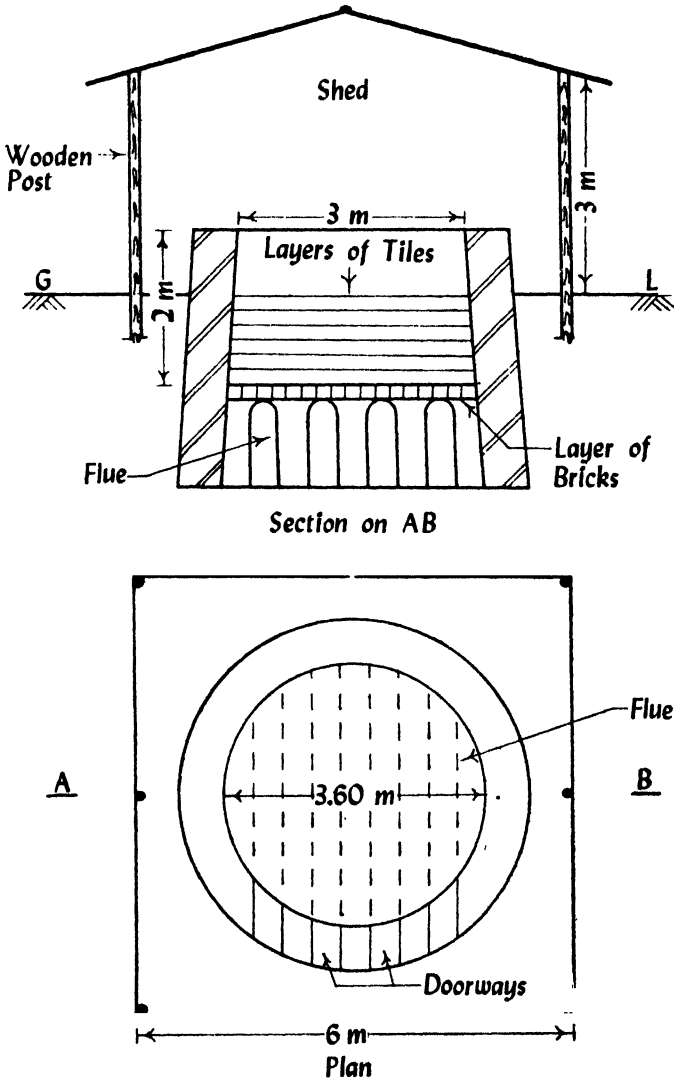

Circular kiln for burning tiles

FIG. 2-1

period of about 6 hours and again raised to white heat, temperature being  $1300^{\circ}\text{C}$ . This temperature is maintained steady for a period of 3 hours. Process of slackening the

fire for 6 hours and then raising the temperature to white heat is repeated. White heat is maintained for 4 hours. Finally, flues are filled with fuel and doorways are closed by brickwork in mud. The kiln is then gradually allowed to cool down. It requires about 72 hours to complete the process of burning the tiles.

Tiles are taken out of the kiln. Underburnt tiles are sorted out and they are placed on the top of kiln in the subsequent burning of tiles.

### ***Characteristics of a good tile:***

- (1) It should be free from any cracks, flaws or bends.
- (2) It should be regular in shape and size.
- (3) It should be sound, hard and durable.
- (4) It should be well burnt.
- (5) It should give a clear ringing sound when struck with hand or with one another or with light hammer.
- (6) It should fit in properly, when placed in position.
- (7) It should give an even and compact structure when seen on its broken surface.
- (8) It should possess uniform colour.

### ***Types of tiles:***

Depending upon the use to which tiles are put, the following are their different types:

- (1) Drain tiles
- (2) Floor tiles
- (3) Roof tiles.

#### ***(1) Drain tiles:***

These tiles are prepared in such a way that they retain porous texture after burning. Hence, when such tiles are laid in waterlogged areas, they allow subsoil water to pass through their skeleton. These drains may be circular, semi-circular or segmental. They are also used to convey irrigation water. Such drain tiles are rarely adopted in modern times.

(2) *Floor tiles :*

Floor tiles may be square or hexagonal in shape. These are flat tiles and their thickness varies from 12 mm to 50 mm. Size of square tiles varies from 150 mm to 300 mm. Floor tiles should be hard and compact so that they can resist wear and tear in a better way. Floor tiles with thinner section can be adopted for ceiling also. To prepare coloured floor tiles, colouring substance is added in the clay at the time of its preparation. Floor tiles of comparatively less strength can be adopted for fixing on walls.

(3) *Roof tiles :*

These tiles are used to serve as covering for pitched roof. Various types of roof tiles are available in the market. Their important varieties are as follows:

(i) Allahabad tiles:

These tiles are made from selected clay. Moulding of clay is done under pressure in machines. Burning of these tiles is done in such a way that they attain more strength. These tiles are provided with projections so that they interlock with each other, when placed in position. Tiles of special shapes are made for hip, ridge and valley portions of the roof.

(ii) Corrugated tiles:

These tiles have corrugations and when they are placed in position, a side lap of one or two corrugations is formed. Placing of such tiles on a roof gives an appearance of corrugated galvanised iron sheets.

(iii) Flat tiles:

These are ordinary floor tiles. To fix them on battens, two or more holes are provided on their surface. Suitable laps are provided at sides and edges.

(iv) Manglore tiles:

These tiles are of flat pattern and they are provided with suitable projections so that they interlock with each other,

when placed in position. These tiles are red in colour and made of double channelled Basel Mission Manglore pattern. Special manglore tiles are available for hip, ridge and valley portions of the roof. It is found that about fifteen manglore tiles are required for covering one square metre of roof area.

(v) Pan tiles:

These tiles are short and heavy. They are less curved than pot tiles. Such tiles are moulded flat first and then they are given the required curvature by moulding in suitable forms. Drying and burning of tiles are done carefully to get better quality of tiles.

(vi) Pot tiles:

These are ordinary half round country tiles. They are prepared on potter's wheel and shape is given to such tiles by a potter with his wet hands. Polishing of inner and outer surfaces is done either with a wet cloth or a wetted strip of leather. These tiles are semi-circular in section and their length is about 20 cm. They are placed on the roof with their concave and convex sides uppermost alternatively. An overlap of at least 80 mm is provided at edges, when these tiles are used. These tiles are liable to break easily and hence, they require frequent replacement.

### **Terra-cotta:**

Terra means *earth* and cotta means *baked*. Hence terra-cotta means *baked earth*. It is thus a type of earthenware.

### ***Manufacture of terra-cotta:***

Following *four* distinct operations are involved in the manufacture of terra-cotta:

- (1) Preparation of clay
- (2) Moulding
- (3) Drying
- (4) Burning.

Each operation will now be briefly described.

(1) *Preparation of clay:*

For terra-cotta, selected clay is taken. The clay should contain a slightly higher percentage of iron oxide, about 5 to 8 per cent and proportion of lime should be less, about 1 per cent or so. Sometimes, several varieties of clay with high alumina content are taken and then, to this mixture is added sand, ground glass, old terra-cotta or pottery. Addition of such materials gives strength and rigidity to terra-cotta products and it prevents shrinking while drying.

Such clay is made free from any impurity such as grit, pebbles, organic matter, etc. It is then finely crushed and pulverised. Water is added in required quantity and the ingredients are thoroughly mixed with spades. Such wet clay is kept for several days in a damp condition for weathering and tempering. It is then pressed or kneaded in a pug mill and it is made ready for the next operation of moulding. The required quantity of colouring substance is added at this stage to obtain the desired shade of colour in the final product of terra-cotta.

(2) *Moulding:*

Clay is placed in moulds which represent the pattern or shape in which the product is to be formed. For terra-cotta work, special moulds of plaster of Paris or templates of zinc are used. Size of moulds is determined by keeping due allowance for shrinkage. Fine sand is sprinkled on the inside surface of moulds and clay is then pressed in moulds with hand.

(3) *Drying:*

Moulds filled in with clay are kept for some days for drying. After this period, articles of terra-cotta are taken out from moulds and they are allowed to dry further in a room or under a shed. Drying should be done carefully and slowly with proper control of temperature.

(4) *Burning:*

Dried products are then burnt in special muffle furnaces.

Fig. 2-2 shows a typical muffle furnace. A muffle indicates a box or a compartment of a furnace in which things can be heated without contact with the fuel and its products. A damper indicates a metal plate which is provided in an opening to regulate the draught. Dried articles are arranged in muffle and temperature of kiln is raised to about  $1200^{\circ}\text{C}$ . This temperature is maintained for about four days and the burnt products are then allowed to cool down in kiln for a period of about five days. For getting the glazed products, glazed materials should be applied by brush on terra-cotta products before they are burnt.

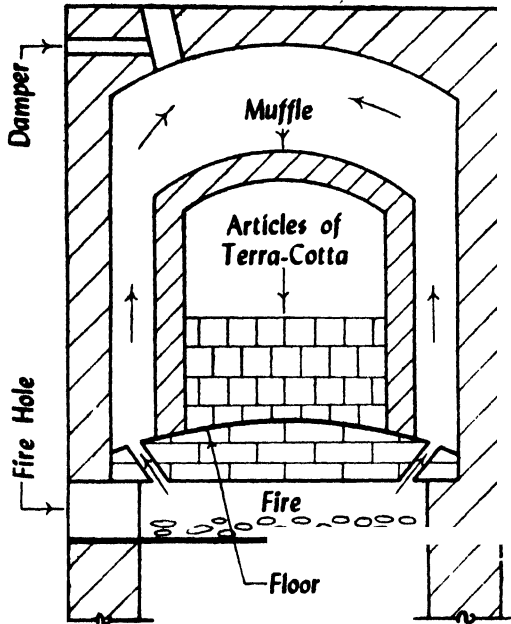

Muffle furnace

FIG. 2-2

### ***Varieties of terra-cotta:***

Terra-cotta articles are of the following *two* types:

- (1) Porous terra-cotta
- (2) Polished terra-cotta.

#### ***(1) Porous terra-cotta:***

To prepare porous terra-cotta, saw dust or ground cork

is added in clay before the stage of moulding. When articles from such clay are burnt in a kiln, organic particles are burnt and they leave pores in the articles. Porous terra-cotta is a fire proof and a sound proof material. It can be sawn and nailed easily with nails, screws, etc. It is light in weight, but it is structurally weak.

(2) *Polished terra-cotta:*

This is also known as *fine terra-cotta* or *faience*. To obtain this variety of terra-cotta, articles are burnt at a lower temperature of about 650°C. First burning is known as *biscuiting*. Articles brought to biscuit stage are removed from kiln and are allowed to cool down. They are then coated with glazing compound and burnt again in the kiln at a temperature of about 1200°C. Faience is available in a variety of colours and it indicates superior quality of terra-cotta.

***Advantages of terra-cotta:***

- (1) It is a strong and durable material.
- (2) It is available in different colours.
- (3) It is cheaper than ordinary finely dressed stones.
- (4) It is easily cleaned.
- (5) It is easily moulded in desired shapes.
- (6) It is fire proof and can, therefore, be conveniently used with R.C.C. work.
- (7) It is light in weight.
- (8) It is not affected by atmospheric agencies and acids.

***Disadvantages of terra-cotta:***

- (1) It cannot be fixed during the progress of work. But it is to be fixed when the work is in final stage of completion.
- (2) It is twisted due to unequal shrinkage in drying and burning.

***Uses of terra-cotta:***

- (1) Hollow terra-cotta blocks are used for various ornamental purposes such as facing work, arches, cornices, casing for columns, etc.

- (2) It is adopted for ornamental work.
- (3) It is used as a decorative material in place of stones.

**Earthenware:**

The term earthenware is used to indicate wares or articles prepared from clay which is burnt at low temperature and cooled down slowly. Clay is mixed with required quantity of sand, crushed pottery, etc. Addition of such materials prevents the shrinkage during drying and burning. Earthenwares are generally soft and porous. When glazed, earthenwares become impervious to water and they are not affected by acids or atmospheric agencies. Terra-cotta is a kind of earthenware.

**Stoneware:**

The term stoneware is used to indicate wares or articles prepared from refractory clays which are mixed with stone and crushed pottery. Such a mixture is then burnt at a high temperature and cooled down slowly. Stoneware is more compact and dense than earthenware. When glazed, stonewares become impervious to water and they are not affected by acids or atmospheric agencies. Sound stonewares give clear ringing sound when struck with each other.

Stonewares are strong, durable and resistant to corrosive fluids. Stonewares can be kept clean easily and hence, they have become very popular as sanitary articles, such as wash basins, sewer pipes, glazed tiles, water closets, gully traps, etc. They are also used to hold chemicals.

**Porcelain:**

The term porcelain is used to indicate a fine earthenware which is white, thin and semi-transparent. Since the colour of porcelain is white, it is also referred to as *whiteware*. Clay of sufficient purity and possessing high degree of tenacity and plasticity is used in preparing porcelains. It is hard, brittle and non-porous. It is prepared from clay, felspar, quartz and minerals. The constituents are finely ground and then they are thoroughly mixed in liquid state. The mixture

is given the desired shape and it is burnt at high temperature. Various types of porcelains are available and they are adopted for various uses such as sanitarywares, electric insulators, storage vessels, reactor chambers, crucibles, etc.

Porcelains are of *two* types, namely, low voltage porcelain and high voltage porcelain.

Low voltage porcelain is prepared by dry process and it is mainly used for switch block, insulating tubes, lamp sockets, etc. If some quantity of alumina or silicate of magnesia is added, it can resist high temperature to a certain extent.

High voltage porcelain is prepared by wet process. Table 2-1 shows the varieties of high voltage porcelain.

**TABLE 2-1**  
**HIGH VOLTAGE PORCELAIN**

Sr. No.	Name	Properties	Uses
1.	Carbon and graphite	It is a refractory material of high quality. But it is oxidised at high temperature.	It is used for making electrodes and in the construction of atomic reactor rockets.
2.	Carbon brick	It is prepared from powder coke and tar. It can resist high temperature.	It is used as lining material for electric furnace.
3.	Cordierite porcelain	It contains 22% alumina, 35% clay and 43% silicate of magnesia. It is available in porous, partly porous and glassy form.	It is used for electric furnace, refractory bricks, etc.
4.	Steatic porcelain	It contains 70 to 90% silicate of magnesia.	It is used as electrical insulator for high intensity electric current, vacuum tubes, etc.
5.	Zircon porcelain	It contains 45 to 60% zircon, 15 to 30% clay and 15 to 30% silicate of zircon. Its dielectric constant at high temperature is good.	It is used in the manufacture of spark plugs.

### Glazing:

Surfaces of clay products are sometimes glazed. A glaze is a glassy coat of thickness about 0.1 mm to 0.2 mm applied

on the surface of an item and then fused into place by burning at high temperature. Following are the *purposes* for which glazing is done:

- (1) To improve the appearance.
- (2) To make the articles durable and impervious.
- (3) To produce decorative effects.
- (4) To protect the articles from action of atmospheric agencies, chemicals, sewage, etc.
- (5) To provide smooth surface.

Glazing may be transparent like glass or it may be opaque like enamels. For obtaining coloured glazes, oxides and salts of various metals or special refractory colouring agents are added. For instance, addition of copper oxides will impart green colour and addition of iron oxide will impart red and brown colours.

### ***Transparent glazing:***

This type of glazing may be given by the following *two* methods:

- (1) Salt glazing
  - (2) Lead glazing.
- (1) *Salt glazing:*

In this method, a small quantity of sodium chloride or salt is added in the kiln at high temperature. Salt is vapourised at a high temperature and a glass like glaze is formed on the surface of articles due to sticking of vapour of salt. This method is useful for sanitary pipes and chemical stonewares. Quantity of salt and throwing it at proper time should be done with extreme care.

- (2) *Lead glazing:*

For getting articles of better quality, lead glazing is preferred to salt glazing. In this method, the article is once burnt and it is then dipped in a bath containing oxide of lead and tin. The article is taken out from the bath and it is reburnt at a high temperature. Particles of oxide of lead and tin melt and they form a film of glass over the exposed surfaces of the article. This method is used for terra-cotta.

**Opaque glazing:**

This type of glazing is adopted to give better appearance than that given by the burnt material. Superior clay is finely powdered and dried. Sufficient quantity of water is added to such clay to make a plastic cream like substance, known as *slip*. Articles to be glazed are dipped in slip before burning and they are subsequently heated. Burning of articles results into the flow of clay particles and an opaque glaze surface is formed.

**Clay blocks:**

Blocks can be prepared from clay and they are used in the construction of partitions. Such blocks may be either solid or hollow. Fig. 2-3 shows a typical hollow clay block.

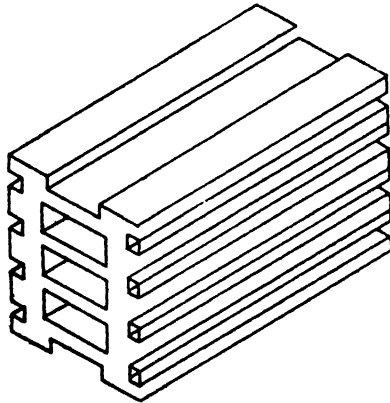

Hollow clay block

FIG. 2-3

Blocks are usually of section 30 cm  $\times$  20 cm and the thickness of hollow blocks varies from 50 mm to 15 cm. The thickness, in case of solid block, is about 40 mm. Blocks are provided with grooves on top, bottom and sides. These grooves help in making the joints rigid and they serve as a key to plaster. Sometimes, the surfaces of blocks are made glazed in a variety of colours.

It is found that partitions of clay blocks are efficient in preventing fire and passage of sound. They are light in weight and are non-shrinkable.

## II. Refractories:

The term *refractories* is used to indicate substances that are able to resist high temperatures. The desired properties of refractories are as follows:

- (1) It must possess excellent resistance to rapid changes in temperature.
- (2) Its dimensional stability, i.e., resistance to change in volume at high temperature, should be excellent.
- (3) It should be strong, i.e., it must be capable of resisting compressive, crushing and tensile forces in hot or cold conditions.
- (4) It should not fall into pieces at high temperatures.
- (5) Its melting point should be high.
- (6) Its thermal conductivity should be suitable for the purpose for which it is to be used.

### *Classification of refractory materials:*

The refractory materials are classified in the following *two* ways:

- (1) according to chemical properties, and
- (2) according to resistance to temperature.

#### (1) *According to chemical properties:*

The refractory materials are divided into the following *three* categories as per their chemical properties:

- (i) acidic, (ii) basic, and (iii) neutral.

Tables 2-2, 2-3, and 2-4 show the acidic, basic and neutral refractory materials respectively.

**TABLE 2-2**  
ACIDIC REFRACTORY MATERIALS

Sr.No.	Name	Properties	Uses
1.	Fire-clay	Its important constituents are alumina and silica.	It is used for manufacture of fire-bricks, crucibles, lining materials for furnaces, hollow tiles, etc.
2.	Quartzite	It is a metamorphic stone. It is hard, brittle, crystalline and compact. Its melting point varies from 1650°C to 1720°C.	It is used for making silica bricks.
3.	Silica	It is available in the form of sand with some impurities from river bed. It melts at 1730°C.	It is used for preparing silica bricks, coke oven and lining for glass furnaces.

**TABLE 2-3**  
**BASIC REFRACTORY MATERIALS**

Sr.No.	Name	Properties	Uses
1.	Dolomite	It is carbonate of lime and magnesium. Its melting point varies from 2300°C to 2600°C.	It is used for making refractory bricks.
2.	Magnesia	It is available in crystal-line form. It melts at 2800°C.	It is used for preparing magnesia bricks.

**TABLE 2-4**  
**NEUTRAL REFRACTORY MATERIALS**

Sr.No.	Name	Properties	Uses
1.	Bauxite	It is mixed with clay and finely ground. Its melting point is 1200°C. It is an amorphous substance with dirty-white, brown or reddish-brown colour.	It is used for preparing fire-bricks containing more percentage of silica.
2.	Carbon	It is available in three forms—amorphous carbon, graphite and diamond. Its melting point is 3500°C.	It is used as activated carbon, absorbent, catalyst, etc. It is also used as lining material for furnaces.
3.	Chromite	It is the oxide of iron and chromium. Its melting point is 2180°C.	It is the most powerful neutral refractory material.
4.	Forsterite	It does not spall easily and it maintains well its volume at high temperature. Its melting point is 1890°C.	It is widely used in the furnace for melting copper.

(2) *According to resistance to temperature:*

The refractory materials are divided into the following two categories as per their capacity to resist temperature:

- (i) low quality, and
- (ii) high quality.

Low quality refractory materials are used in the manufacture of fire-bricks, as lining material for furnaces, etc. The melting point of such materials is more than 1580°C.

High quality refractory materials are stable even at high temperature and they are used in the construction of modern

aeroplanes such as rockets, jets, etc. These materials are composed of either pure clay or metals or combination of clay and metals. High quality refractory materials containing pure clay are pure oxides of alumina, magnesia, etc. or nitrides or carbides. Those metals which melt at a temperature of about  $1600^{\circ}\text{C}$  can be used as metal refractories. Such metals are molybdenum, tungsten, zirconium, etc. These metals and their alloys are used as refractory materials. The term *cermet* (*cer* from ceramics and *met* from metals) is used to indicate the refractory materials containing a combination of clay and metal. The usual percentages are 80% clay and 20% metal. The usual metals employed for cermets are aluminium, chromium, cobalt, iron, etc. Cermets are widely used where shocks due to sudden changes of temperature are to be resisted.

### QUESTIONS

1. Explain what is meant by the terms ceramics and clay.
2. How are tiles manufactured?
3. What are the characteristics of a good tile?
4. Write short notes on:
  - (1) Manglore tiles
  - (2) Pot tiles
  - (3) Faience
  - (4) Salt glazing
  - (5) Muffle furnace
  - (6) Opaque glazing
  - (7) Cermets
  - (8) Coloured glazes
  - (9) Porcelain
  - (10) Clay products.
5. Describe various types of tiles.
6. What is terra-cotta? How is it manufactured?
7. Discuss the varieties of terra-cotta.
8. State advantages, disadvantages and uses of terra-cotta.
9. Explain what is meant by earthenware, stoneware and porcelain.

10. What is a glaze? Mention the purposes of glazing and discuss its varieties.
11. Write a critical note on the use of clay blocks for partitions.
12. Mention properties and uses of the varieties of high voltage porcelain.
13. What is meant by the term refractories? Mention the desired properties of refractories.
14. How are refractory materials classified?
15. State the properties and uses of the acidic, basic and neutral refractories.
16. Discuss low quality and high quality refractory materials.
17. Differentiate between the following:
  - (1) Floor tiles and roof tiles
  - (2) Porous terra-cotta and polished terra-cotta
  - (3) Earthenware and stoneware
  - (4) Salt glazing and lead glazing
  - (5) Pan tiles and pot tiles
  - (6) Low voltage porcelain and high voltage porcelain
  - (7) Muffle and damper
  - (8) Low quality and high quality refractory materials
  - (9) Earthenware and whiteware
  - (10) Quartzite and bauxite
  - (11) Dolomite and forsterite.
18. Give reasons for the following:
  - (1) A mixture of ground glass and potteryware is sometimes added to clay of tiles.
  - (2) Tiles are dried under a shade.
  - (3) Stonewares have become very popular as sanitary articles.
  - (4) Floor tiles should be hard and compact.
  - (5) Clay blocks are provided with grooves on top, bottom and sides.

# Chapter 3

## BRICKS

### **General:**

Bricks are obtained by moulding clay in rectangular blocks of uniform size and then by drying and burning these blocks. As bricks are of uniform size, they can be properly arranged and further, as they are light in weight, no lifting appliance is required for them. Thus, at places where stones are not easily available, but if there is plenty of clay, bricks replace stones.

### **Comparison of brickwork and stonework:**

Brickwork is superior to stonework in the following respects:

- (1) At places where stones are not easily available but where there is plenty of clay, brickwork becomes cheaper than stonework.
- (2) Cost of construction works out to be less in case of brickwork than stonework as less skilled labour is required in the construction of brickwork.
- (3) No complicated lifting devices are necessary to carry bricks as they can be easily moved by manual labour.
- (4) Bricks resist fire better than stones and hence, in case of a fire, they do not easily disintegrate.
- (5) Bricks of good quality resist various atmospheric effects in a better way than stones.
- (6) In case of brickwork, mortar joints are thin and hence, the structure becomes more durable.
- (7) It is easy to construct connections and openings in case of brickwork than stonework.

Brickwork is inferior to stonework in the following respects:

- (1) Brickwork is less watertight than stonework. Bricks absorb moisture from the atmosphere and dampness can enter the building.
- (2) Brickwork does not create a solid appearance in relation to stonework and hence, for public buildings and monumental structures, stonework is found to be more useful than brickwork.
- (3) Stonework is stronger than brickwork.
- (4) Better architectural effects can be developed by stonework.
- (5) Stonework is cheaper at places where stones are easily available.

### **Composition of good brick earth:**

Following are the constituents of good brick earth:

#### **(1) *Alumina:***

It is the chief constituent of every kind of clay. A good brick earth should contain about 20 to 30 per cent of alumina. This constituent imparts plasticity to earth so that it can be moulded. If alumina is present in excess, raw bricks shrink and warp during drying and burning.

#### **(2) *Silica:***

It exists in clay either as free or combined. As free sand, it is mechanically mixed with clay and in combined form, it exists in chemical composition with alumina. A good brick earth should contain about 50 to 60 per cent of silica. Presence of this constituent prevents cracking, shrinking and warping of raw bricks. It thus imparts uniform shape to the bricks. Durability of bricks depends on the proper proportion of silica in brick earth. Excess of silica destroys the cohesion between particles and bricks become brittle.

#### **(3) *Lime:***

A small quantity of lime is desirable in good brick earth. It should be present in a finely powdered state and not in lump form. Lime prevents shrinkage of raw bricks. Sand

alone is infusible. But it slightly fuses at kiln temperature in presence of lime. Such fused sand works as a hard cementing material for brick particles. Excess of lime causes the brick to melt and hence, its shape is lost. Lumps of lime are converted into quick lime after burning and this quick-lime slakes and expands in presence of moisture. Such an action results in splitting of bricks into pieces.

#### (4) *Oxide of iron:*

A small quantity of oxide of iron to the extent of about 5 to 6 per cent is desirable in good brick earth. It helps as lime to fuse sand. It also imparts red colour to bricks. Excess of oxide of iron makes the bricks dark blue or blackish. If, on the other hand, the quantity of iron oxide is comparatively less, the bricks will be yellowish in colour.

#### (5) *Magnesia:*

A small quantity of magnesia in brick earth imparts yellow tint to bricks and decreases shrinkage. But excess of magnesia leads to the decay of bricks.

### **Harmful ingredients in brick earth:**

Following are the ingredients which are undesirable in brick earth:

#### (1) *Lime:*

Adverse effects of excess lime and lime in lumps are already discussed above.

#### (2) *Iron pyrites:*

If iron pyrites are present in brick earth, bricks are crystallised and disintegrated during burning.

#### (3) *Alkalies:*

These are mainly in the form of soda and potash. Alkalies act as a flux in the kiln during burning and they cause bricks to fuse, twist and warp. As a result, bricks are melted and they lose their shape. Further, alkalies remaining in bricks will absorb moisture from the atmosphere, when bricks are used in masonry. Such moisture, when

evaporated, leaves behind grey or white deposits on the wall surface. Appearance of the building as a whole is then seriously spoiled.

**(4) Pebbles:**

Presence of pebbles or grits of any kind is undesirable in brick earth. Brick containing pebbles will not break regularly as desired.

**(5) Organic matter:**

Presence of organic matter in brick earth assists in burning. But if such matter is not completely burnt, bricks become porous.

**Classification of brick earth:**

Brick earth is classified in the following *three* categories:

- (1) Loamy, mild or sandy clay
- (2) Marls, chalky or calcareous clay
- (3) Plastic, strong or pure clay.

**(1) Loamy, mild or sandy clay:**

This type of earth consists of considerable amount of free silica in addition to alumina. Presence of sand helps in preventing cracking, shrinking and warping of bricks. Addition of lime in such clay helps to fuse sand and thereby to increase hardness of bricks. A typical analysis of such clay is as follows:

Alumina .....	27 %
Silica .....	66 %
Lime and magnesia .....	1 %
Oxide of iron .....	1 %
Organic matter .....	5 %
Total	100 per cent.

**(2) Marls, chalky or calcareous clay:**

This clay consists of considerable amount of chalk in addition to alumina and silica. Such clay generally makes

good bricks. But to avoid undesirable effects of excess lime, sand is sometimes added to such clay. A typical analysis of such clay is as follows:

Alumina .....	10 %
Silica .....	35 %
Lime and magnesia .....	48 %
Oxide of iron .....	3 %
Alkalies .....	4 %
Total	100 per cent.

### (3) *Plastic, strong or pure clay:*

This clay consists of alumina and silica and it is sometimes referred to as strong clay or fat clay. Raw bricks will crack, shrink and warp during drying, if pure clay alone is used in making of bricks. Hence such clay is corrected by the addition of sand and ash. Sand prevents shrinkage and ash provides lime to act as flux. A typical analysis of such clay is as follows:

Alumina .....	34 %
Silica .....	50 %
Lime and magnesia .....	6 %
Oxide of iron .....	8 %
Organic matter .....	2 %
Total	100 per cent.

It should be noted that the best guide in the selection of brick clay would be the preparation of sample bricks from such clay. Sample bricks should be burnt in a simple kiln and their behaviour in drying and burning should be carefully noted. Sample bricks should be exposed to sun and wind and their various properties should be tested to determine their utility. If result is satisfactory, such clay should be adopted to manufacture bricks on a large scale. Otherwise, necessary ingredients may be added to such clay to make it fit for brick making.

### **Manufacture of bricks:**

In the process of manufacturing bricks, the following *four* distinct operations are involved:

- (1) Preparation of clay
- (2) Moulding
- (3) Drying
- (4) Burning.

Each operation will now be studied at length.

**(1) Preparation of clay:**

Clay for bricks is prepared in the following order:

- (i) Unsoiling
- (ii) Digging
- (iii) Cleaning
- (iv) Weathering
- (v) Blending
- (vi) Tempering.

**(i) Unsoiling:**

The top layer of soil, about 20 cm in depth, is taken out and thrown away. Clay in top soil is full of impurities and hence, it is to be rejected for the purpose of preparing bricks.

**(ii) Digging:**

Clay is then dug out from the ground. It is spread on the levelled ground, just a little deeper than the general level of ground. Height of heaps of clay is about 60 cm to 120 cm.

**(iii) Cleaning:**

Clay, as obtained in the process of digging, should be cleaned of stones, pebbles, vegetable matter, etc. Lumps of clay should be converted into powder form.

**(iv) Weathering:**

Clay is then exposed to atmosphere for softening or mellowing. The period of exposure varies from few weeks to full season. For a large project, clay is dug out just before the monsoon and it is allowed to weather throughout the monsoon.

(v) *Blending:*

Clay is made loose and any ingredient to be added to it, is spread out at its top. Blending indicates intimate or harmonious mixing. It is carried out by taking small portion of clay every time and by turning it up and down in vertical direction. Blending makes clay fit for the next stage of tempering.

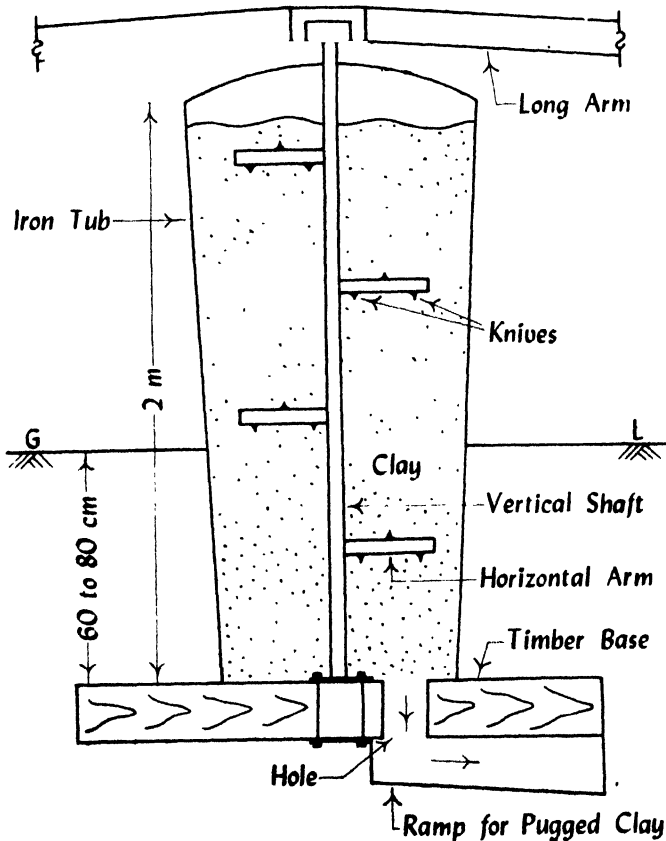
(vi) *Tempering:*

Pug mill

FIG. 3-1

In the process of tempering, clay is brought to a proper degree of hardness and it is made fit for the next operation of moulding. Water in required quantity is added to clay and the whole mass is kneaded or pressed under the feet of

men or cattle. Tempering should be done exhaustively to obtain homogeneous mass of clay of uniform character.

For manufacturing good bricks on a large scale, tempering is usually done in a pug mill. A typical pug mill is shown in fig. 3-1. Process of grinding clay with water and making it plastic is known as *pugging*. A pug mill consists of a conical iron tub with cover at its top. It is fixed on a timber base which is made by fixing two wooden planks at right angles to each other. Bottom of tub is covered except for the hole to take out pugged earth. Diameter of pug mill at bottom is about 80 cm and that at top is about one metre. Provision is made in top cover to place clay inside the pug mill. A vertical shaft with horizontal arms is provided at the centre of iron tub. Small wedge-shaped knives of steel are fixed on horizontal arms. Long arms are fixed at the top of vertical shaft to attach a pair of bullocks. Ramp is provided to collect the pugged clay. Height of pug mill is about 2 m and its depth below ground is about 60 cm to 80 cm.

In the beginning, hole for pugged clay is closed and clay with water is placed in pug mill from the top. When the vertical shaft is rotated or turned by a pair of bullocks, clay is thoroughly mixed up by the actions of horizontal arms and knives. Rotation of vertical shaft can also be achieved by some mechanical power. When clay has been sufficiently pugged, hole at the bottom of tub, is opened out and the pugged earth is taken out from ramp for the next operation of moulding. Pug mill is then kept moving and feeding of clay from top and taking out of pugged clay from bottom are done simultaneously. If tempering is properly carried out, the good brick earth can then be rolled without breaking in small threads of 3 mm diameter.

## (2) *Moulding:*

Clay which is prepared as above is then sent for the next operation of moulding. Following are the *two* ways of moulding:

- (i) Hand moulding
- (ii) Machine moulding.

(i) *Hand moulding*:

Moulds are rectangular boxes which are open at top and bottom. They may be of wood or steel.

A typical wooden mould is shown in fig. 3-2. It should be prepared from well seasoned wood. Longer sides are kept slightly projecting to serve as handles. Strips of brass or steel are sometimes fixed on the edges of wooden moulds to make them more durable.

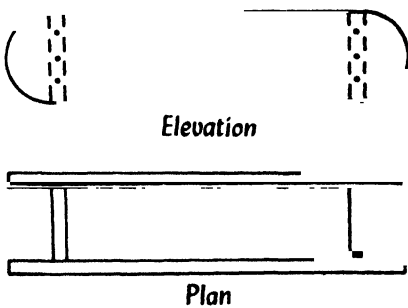

Wooden mould  
FIG. 3-2

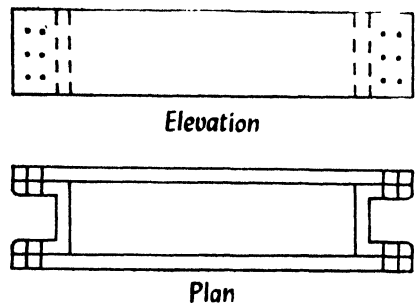

Steel mould  
FIG. 3-3

A typical steel mould is shown in fig. 3-3. It is prepared from the combination of steel plates and channels. It may even be prepared from steel angles and plates. Thickness of steel mould is generally 6 mm. They are used for manufacturing bricks on a large scale. Steel moulds are more durable than wooden moulds and they turn out bricks of uniform size.

Bricks shrink during drying and burning. Hence moulds are to be made larger than the size of fully burnt bricks. Moulds are, therefore, made longer by about 8 to 12 per cent in all directions. Exact percentage of increase in dimensions of mould is determined by actual experiment on clay to be used for preparing bricks.

Bricks prepared by hand moulding are of *two* types:

- (a) Ground-moulded bricks
- (b) Table-moulded bricks.

(a) Ground-moulded bricks:

Ground is first made level and fine sand is sprinkled over it. Mould is dipped in water and placed over the ground. Lump of tempered clay is taken and it is dashed in the mould. Clay is passed or forced in the mould in such a way that it fills all the corners of mould. Extra or surplus clay is removed either by wooden strike or metal strike or frame with wire. A strike is a piece of wood or metal with a sharp edge. It is to be dipped in water every time. Mould is then lifted up and raw brick is left on the ground. Mould is dipped in water and it is placed just near the previous brick to prepare another brick. Process is repeated till the ground is covered with raw bricks. When such bricks become sufficiently dry, they are carried and placed in drying sheds.

Bricks prepared by dipping mould in water every time are known as *slop-moulded bricks*. Fine sand or ash may be sprinkled on the inside surface of mould instead of dipping mould in water. Such bricks are known as *sand-moulded bricks* and they have sharp and straight edges.

Lower faces of ground moulded bricks are rough and it is not possible to place frog on such bricks. A frog is a mark of depth about 10 mm to 20 mm which is placed on raw brick during moulding. It serves *two* purposes:

- (1) It indicates the trade name of the manufacturer.
- (2) In brickwork, bricks are laid with frog uppermost. It thus affords a key for mortar when the next brick is placed over it.

Ground-moulded bricks of better quality and with frogs on their surface are made by using a pair of pallet boards and a wooden block. A pallet is a piece of thin wood. Block is bigger than mould and it has a projection of about 6 mm height on its surface. Dimensions of projection correspond to the internal dimensions of mould. Design of impression or frog is made on this block. This wooden block is also known as moulding block or stock board. Mould is placed to fit in the projection of wooden block and clay is then dashed inside the mould. A pallet is placed on the top and the whole thing is then turned upside down. Mould

is taken out and another pallet is placed over the raw brick and it is conveyed to the drying sheds. Bricks are placed to stand on their longer sides in drying sheds and pallet boards are brought back for using them again. As the bricks are laid on edge, they occupy less space and they dry quicker and better.

(b) Table-moulded bricks:

Process of moulding these bricks is just similar as above. But in this case, the moulder stands near a table of size about  $2\text{ m} \times 1\text{ m}$ . Clay, mould, water pots, stock board, strikes and pallet boards are placed on this table. Bricks are moulded on the table and sent for the further process of drying.

(ii) *Machine moulding*:

Moulding may also be achieved by machines. It proves to be economical when bricks in huge quantity are to be manufactured at the same spot. It is also helpful for moulding hard and strong clay. These machines are broadly classified in *two* categories:

- (a) Plastic clay machines
- (b) Dry clay machines.

(a) Plastic clay machines:

Such machines contain a rectangular opening of size equal to length and width of a brick. Pugged clay is placed in the machine and as it comes out through the opening, it is cut into strips by wires fixed in frames. Arrangement is made in such a way that strips of thickness equal to that of the brick are obtained. As the bricks are cut by wire, they are also known as *wire cut bricks*.

(b) Dry clay machines:

In these machines, strong clay is first converted into powder form. A small quantity of water is then added to form a stiff plastic paste. Such paste is placed in mould and pressed by machine to form hard and well shaped bricks. These bricks are known as *pressed bricks* and they do not practically require drying. They can be sent directly for the process of burning.

Wire cut and pressed bricks have sharp edges and corners. They have smooth external surfaces. They are heavier than ordinary hand-moulded bricks. They carry distinct frogs and exhibit uniform texture.

### (3) *Drying:*

The damp bricks, if burnt, are likely to be cracked and distorted. Hence moulded bricks are dried before they are taken for the next operation of burning. For drying, bricks are laid longitudinally in stacks of width equal to two bricks. A stack consists of eight or ten tiers. Bricks are laid along and across the stock in alternate layers. All bricks are placed on edge. The important facts to be remembered in connection with drying of bricks are as follows:

#### (i) *Artificial drying:*

Bricks are generally dried by natural process. But when bricks are to be rapidly dried on a large scale, artificial drying may be adopted. In such a case, moulded bricks are allowed to pass through special dryers which are in the form of tunnels or channels. Such dryers are heated with the help of special furnaces or by hot flue gases.

#### (ii) *Circulation of air:*

Bricks in stacks should be arranged in such a way that sufficient air space is left between them for free circulation of air.

#### (iii) *Drying yard:*

For the drying purpose, special drying yards should be prepared. It should be slightly on a higher level and it is desirable to cover it with sand. Such an arrangement would prevent the accumulation of rain water.

#### (iv) *Period for drying:*

Time required by moulded bricks to dry depends on prevailing weather conditions. Usually, it takes about 3 to 10 days for bricks to become dry.

#### (v) *Screens:*

It is to be seen that bricks are not directly exposed to wind or sun for drying. Suitable screens, if necessary, may be provided to avoid such situations.

#### (4) **Burning:**

This is a very important operation in the manufacture of bricks. It imparts hardness and strength to bricks and makes them dense and durable. Bricks should be burnt properly. If bricks are overburnt, they will be brittle and hence, break easily. If they are underburnt, they will be soft and hence, cannot carry loads.

Burning of bricks is done either in clamps or in kilns. Clamps are temporary structures and they are adopted to manufacture bricks on a small scale. Kilns are permanent structures and they are adopted to manufacture bricks on a large scale.

#### **Clamps:**

A typical clamp is shown in fig. 3-4. Following procedure is adopted in its construction:

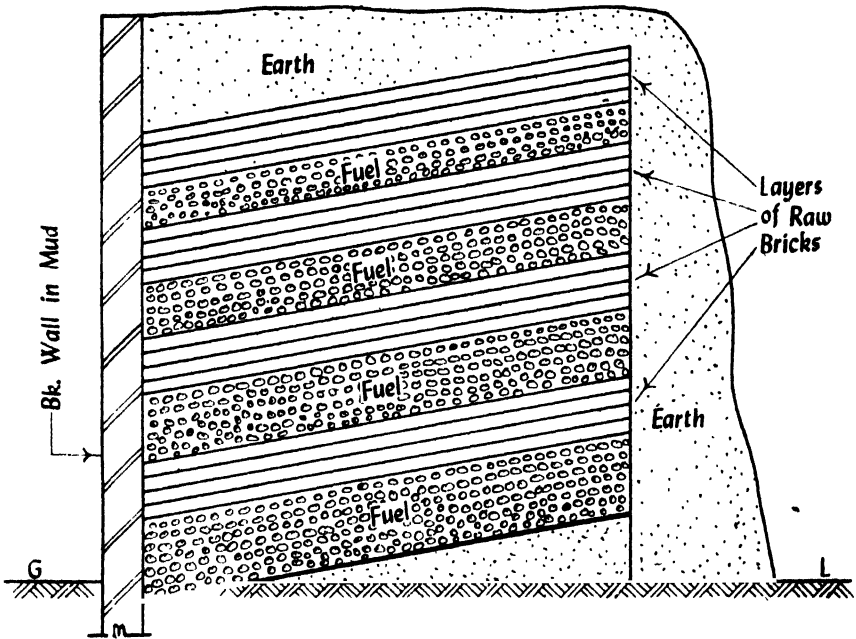

Clamp  
FIG. 3-4

(i) A piece of ground is selected. Its shape in plan is generally trapezoidal. Floor of clamp is prepared in

such a way that short end is slightly in the excavation and wider end is raised at an angle of about  $15^\circ$  from ground level.

(ii) Brick wall in mud is constructed on the short end and a layer of fuel is laid on the prepared floor. Fuel may consist of grass, cow dung, litter, husks of rice or ground nuts, etc. Thickness of this layer is about 70 cm to 80 cm. Wood or coal dust may also be used as fuel.

(iii) A layer, consisting of 4 or 5 courses of raw bricks, is then put up. Bricks are laid on edges with small spaces between them for the circulation of air.

(iv) A second layer of fuel is then placed and over it, another layer of raw bricks is put up. Thus alternate layers of fuel and raw bricks are formed. Thickness of fuel layer gradually decreases as the height of clamp increases.

(v) Total height of a clamp is about 3 m to 4 m. When nearly one third height is reached, lower portion of the clamp is ignited. The object for such an action is to burn the bricks in lower part when the construction of upper part of clamp is in progress.

(vi) When the clamp is completely constructed, it is plastered with mud on sides and top and filled with earth to prevent the escape of heat. If there is any sudden and violent outburst of fire, it is put down by throwing earth or ashes.

(vii) Clamp is allowed to burn for a period of about one to two months.

(viii) It is then allowed to cool for more or less the same period as burning.

(ix) Burnt bricks are then taken out from the clamp.

#### *Advantages of clamp burning:*

(i) Burning and cooling of bricks are gradual in clamps. Hence, bricks produced are tough and strong.

(ii) Burning of bricks by clamps proves to be cheap and economical.

(iii) No skilled labour and supervision are required for the construction of clamps.

(iv) There is considerable saving of fuel.

**Disadvantages of clamp burning:**

(i) Bricks are not of regular shape. This may be due to settlement of bricks when fuel near bottom is burnt and turned to ashes.

(ii) It is a very slow process.

(iii) It is not possible to regulate fire in a clamp.

(iv) Quality of bricks is not uniform. Bricks near the bottom are overburnt and those near sides and top are underburnt.

**Kilns:**

A kiln is a large oven which is used to burn bricks. Kilns which are used in the manufacture of bricks are of the following *two* types:

(i) Intermittent kilns

(ii) Continuous kilns.

**(i) Intermittent kilns:**

These kilns are intermittent in operation which means that they are loaded, fired, cooled and unloaded. Such kilns may either be rectangular or circular in plan. They may be overground or underground. They are classified in *two* ways:

(a) Intermittent up-draught kilns

(b) Intermittent down-draught kilns.

**(a) Intermittent up-draught kilns:**

These kilns are in the form of rectangular structures with thick outside walls. Wide doors are provided at each end for loading and unloading of kilns. Flues are provided to carry flames or hot gases through the body of kiln. A temporary roof may be installed of any light material. Such roof gives protection to raw bricks from rain while they are being placed in position. This roof is to be removed when the kiln is fired. Fig. 3-5 shows the plan of a typical intermittent up-draught kiln. Working of the kiln is as follows:

(1) Raw bricks are laid in rows of thickness equal to 2 to 3 bricks and of height equal to 6 to 8 bricks. A space of about 2 bricks is left between adjacent rows. This space is utilised for placing fuel.

- (2) Fuels are filled with brushwood which takes up a fire easily. Interior portion is then filled with fuel of bigger size.
- (3) An arch like opening is formed by projecting 4 to 5 rows of bricks. Projection of each row is about 30 mm to 40 mm.

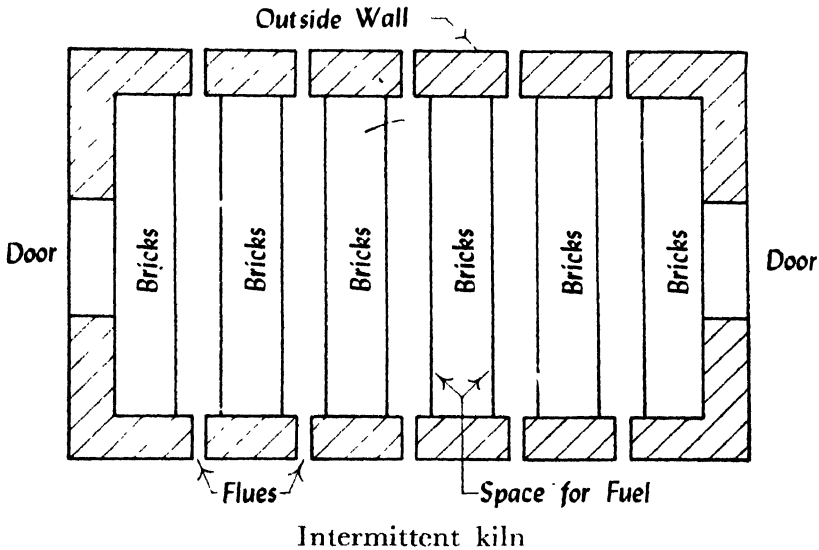

FIG. 3-5

- (4) Loading of kiln with raw bricks is then carried out. Top course is finished with flat bricks. Other courses are formed by placing bricks on edge.
- (5) End doors are built up with dry bricks and are covered with mud or clay.
- (6) Kiln is then fired. For the first three days, firing is kept slow by proper manipulation of flues. Strong fire is maintained for a period of 48 to 60 hours. Draught rises in the upward direction from bottom of kiln and brings about the burning of bricks.
- (7) Kiln is allowed to cool down and bricks are then taken out.
- (8) Procedure is then repeated for the next burning of bricks.

Bricks manufactured by intermittent up-draught kilns are better than those prepared by clamps. But such kilns have the following *disadvantages*:

- (i) Quality of burnt bricks is not uniform. Bricks near bottom are overburnt and those near top are underburnt.
- (ii) Supply of bricks is not continuous.
- (iii) There is wastage of fuel heat as kiln is to be cooled down every time after burning.

(b) Intermittent down-draught kilns:

These kilns are rectangular or circular in shape. They are provided with permanent walls and closed tight roof. Floor of the kiln has openings which are connected to a common chimney stack through flues. Working of this kiln is more or less similar to the up-draught kiln. But it is so arranged in this kiln that hot gases are carried through vertical flues upto the level of roof and they are then released. These hot gases move downward by the chimney draught and in doing so, they burn the bricks.

Following *advantages* are claimed for intermittent down-draught kilns:

- (1) Bricks are evenly burnt.
- (2) Performance of this kiln is better than that of up-draught kiln.
- (3) There is close control of heat and hence, such kilns are useful for burning structural clay tiles, terra-cotta, etc.

(ii) *Continuous kilns*:

These kilns are continuous in operation. This means that loading, firing, cooling and unloading are carried out simultaneously in these kilns. There are various types of continuous kilns. Following *three* varieties of continuous kilns will be discussed:

- (a) Bull's trench kiln
- (b) Hoffman's kiln
- (c) Tunnel kiln.

## (a) Bull's trench kiln:

This kiln may be of rectangular, circular or oval shape in plan. Fig. 3-6 shows a typical Bull's kiln of oval shape in plan. It is constructed in a trench excavated in ground. It may be fully underground or partly projecting above ground. In latter case, the ramps of earth should be provided on outside walls. Outer and inner walls are to be constructed of bricks. Openings are generally provided in the outer walls to act as flue holes. Dampers are in the form of iron plates and they are used to divide the kilns in suitable sections as shown in in fig. 3-6.

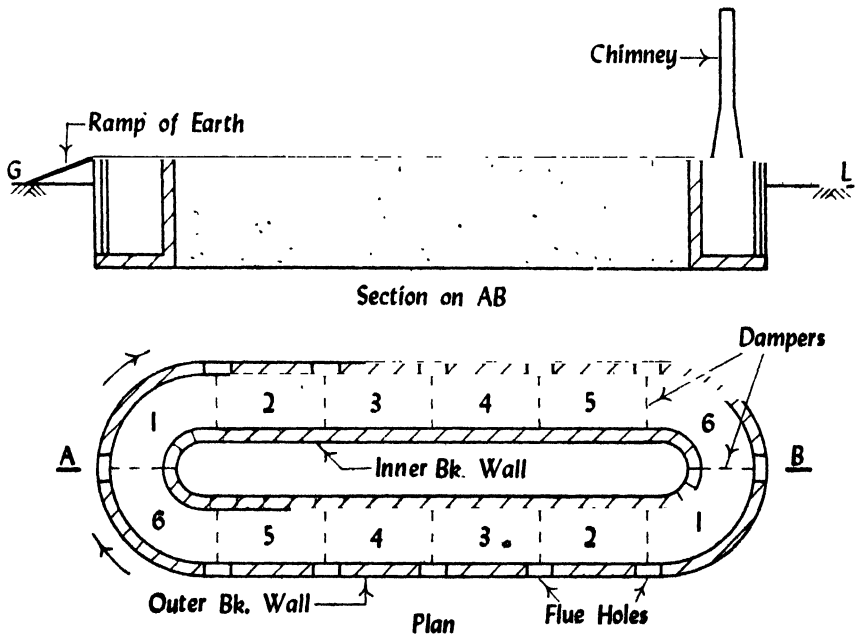

Bull's trench kiln

FIG. 3-6

Bricks are arranged in sections. They are arranged in such a way that flues are formed. Fuel is placed in flues and it is ignited through flue holes after covering top surface with earth and ashes to prevent the escape of heat. A number of flue holes are provided on top to insert fuel when burning is in progress. Usually two movable iron chimneys are employed to form draught. These chimneys are placed in

advance of section being fired. Hence, hot gases leaving the chimneys warm up the bricks in next section. Each section requires about one day to burn. When a section has been burnt, flue holes are closed and it is allowed to cool down gradually. Fire is advanced to next section and chimneys are moved forward as shown by arrows in fig. 3-6.

Bull's trench kiln is working continuously as all the operations—loading, burning, cooling and unloading are carried out simultaneously. Fig. 3-6 shows Bull's kiln with two sets of sections. Two pairs of chimneys and two gangs of workers will be required to operate this kiln. A tentative arrangement for different sections may be as follows:

- Section 1 - - Loading
- Section 2 — Empty
- Section 3 — Unloading
- Section 4 — Cooling
- Section 5 — Burning
- Section 6 — Heating.

(b) Hoffman's kiln:

This kiln is constructed overground and hence, it is sometimes known as *flame kiln*. Its shape is circular in plan and it is divided into a number of compartments or chambers. Fig. 3-7 shows plan and section of Hoffman's kiln with 12 chambers. Each chamber is provided with the following:

- (1) a main door for loading and unloading of bricks,
- (2) communicating doors which would act as flues in open condition,
- (3) a radial flue connected with a central chimney, and
- (4) fuel holes with covers to drop fuel, which may be in the form of powdered coal, into burning chambers.

Main doors are closed by dry bricks and covered with mud, when required. For communicating doors and radial flues, dampers are provided to shut or open them. In the normal condition, only one radial flue is connected to chimney to establish a draught.

In this type of kiln, each chamber performs various functions in succession, namely, loading, drying, burning,

cooling and unloading. As an illustration, 12 chambers shown in fig. 3-7, may be functioning as follows:

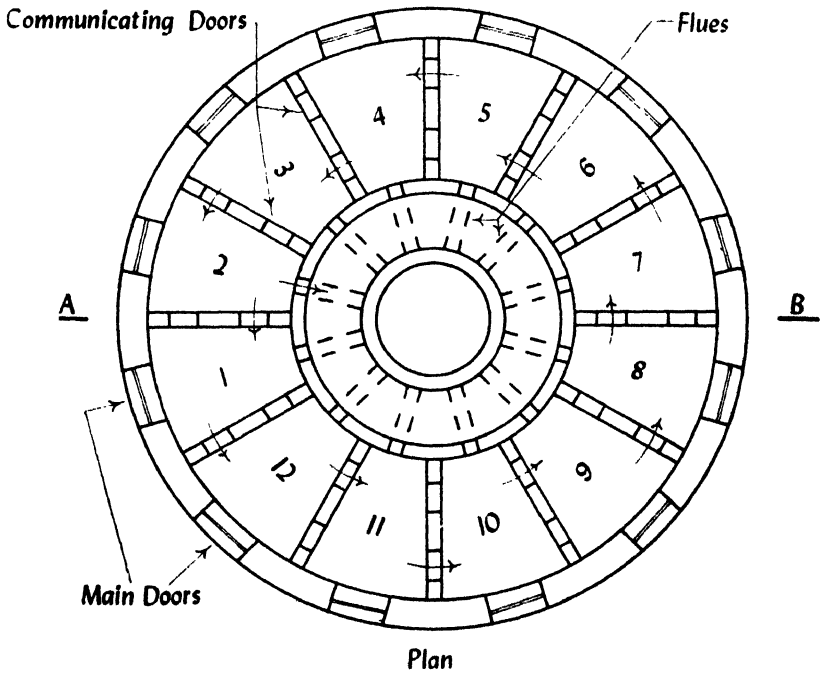
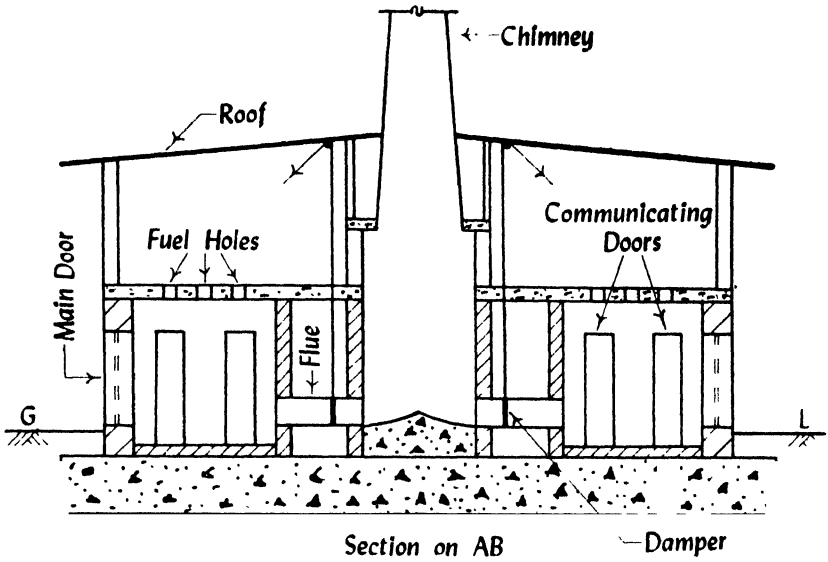

Hoffman's kiln

FIG. 3-7

- Chamber 1 — Loading
- Chambers 2 to 5 — Drying and preheating
- Chambers 6 and 7 — Burning
- Chambers 8 to 11 — Cooling
- Chamber 12 — Unloading.

With the above arrangement, circulation of the flue gas will be as shown by arrows in fig. 3-7. Cool air enters through chambers 1 and 12 as their main doors are open. After crossing the cooling chambers 8 to 11, it enters the burning section in a heated condition. It then moves to chambers 2 to 5 to dry and pre-heat the raw bricks. Damper of chamber 2 is in open condition and hence, it escapes into atmosphere through chimney.

The initial cost of installing this kiln is high, but it possesses the following *advantages*:

- (1) Bricks are burnt equally and evenly. Hence, bricks of good quality are produced.
- (2) It is possible to regulate heat inside the chambers through fuel holes.
- (3) Supply of bricks is continuous and regular.
- (4) There is considerable saving in fuel due to pre-heating of raw bricks by flue gas.

Capacity of the kiln will depend upon the dimensions of chambers. If each chamber is of about 11 m length, 4.50 m average width and 2.50 m height, it will contain about 25000 bricks. Hence if it is so arranged that one chamber is unloaded daily, such a kiln will manufacture about 25000 bricks daily or about 8 to 9 million bricks annually.

#### (c) Tunnel kiln:

This type of kiln is in the form of tunnel which may be straight, circular or oval in plan. It contains a stationary zone of fire. Raw bricks are placed on trolleys which are then moved from one end to the other end of tunnel. Raw bricks get dried and pre-heated as they approach zone of fire. In zone of fire, bricks are burnt to the required degree and they are then pushed forward for cooling. When bricks are sufficiently cooled, they are unloaded. This kiln proves to be economical when bricks are to be manufactured on a

large scale. As temperature is under control, uniform bricks of better quality are produced.

### Comparison between clamp-burning and kiln-burning:

In order to bring out points of differences between similar items of clamp-burning and kiln-burning of bricks, a chart as shown in table 3-1, is prepared:

**TABLE 3-1**  
COMPARISON BETWEEN CLAMP-BURNING AND KILN-BURNING

Sr.No.	Item	Clamp-burning	Kiln-burning
1.	Capacity	About 20000 to 100000 bricks can be prepared at a time.	Average 25000 bricks can be prepared per day.
2.	Cost of fuel	Low as grass, cow dung, litter, etc. may be used.	Generally high as coal dust is to be used.
3.	Initial cost	Very low as no structures are to be built.	More as permanent structures are to be constructed.
4.	Quality of bricks	Percentage of good quality bricks is small about 60% or so.	Percentage of good quality bricks is more about 90% or so.
5.	Regulation of fire	It is not possible to control or regulate fire during the process of burning.	Fire is under control throughout the process of burning.
6.	Skilled supervision	Not necessary throughout the process of burning.	Continuous skilled supervision is necessary.
7.	Structure	Temporary structure.	Permanent structure.
8.	Suitability	Suitable when bricks are to be manufactured on a small scale and when the demand of bricks is not continuous.	Suitable when bricks are to be manufactured on a large scale and when there is continuous demand of bricks.
9.	Time of burning and cooling	It requires about 2 to 6 months for burning and cooling of bricks.	Actual time for burning of one chamber is about 24 hours and only about 12 days are required for cooling of bricks.
10.	Wastage of heat	There is considerable wastage of heat from top and sides and hot flue gas is not properly utilised.	Hot flue gas is used to dry and pre-heat raw bricks. Hence wastage of heat is the least.

**Qualities of good bricks:**

Good bricks which are to be used for the construction of important structures should possess the following qualities:

- (1) Bricks should be table-moulded, well-burnt in kilns, copper-coloured, free from cracks and with sharp and square edges.
- (2) Bricks should be uniform in shape and should be of standard size.
- (3) Bricks should give clear ringing sound when struck with each other.
- (4) Bricks when broken should show homogeneous and compact structure.
- (5) Brick should not absorb water more than 20 per cent by weight for first class bricks and 22 per cent by weight for second class bricks, when soaked in cold water for a period of 24 hours.
- (6) Bricks should be sufficiently hard. No impression should be left on brick surface, when it is scratched with finger nail.
- (7) Bricks should not break when dropped flat on hard ground from a height of about one metre.
- (8) Bricks should have low thermal conductivity and they should be sound-proof.

**Tests for bricks:**

A brick is generally subjected to the following tests to find out its suitability for the construction work:

- (1) Absorption
- (2) Crushing strength
- (3) Hardness
- (4) Presence of soluble salts
- (5) Shape and size
- (6) Soundness
- (7) Structure.

(1) ***Absorption:***

A brick is taken and it is weighed dry. It is then immersed in water for a period of 16 hours. It is weighed again and the difference in weight indicates the amount of water absorbed by the brick. It should not, in any case, exceed 20 per cent of weight of dry brick.

(2) ***Crushing strength:***

Crushing strength of a brick is found out by placing it in a compression testing machine. It is pressed till it breaks. Minimum crushing strength of bricks is 35 kg/cm<sup>2</sup> and for superior bricks, it may vary from 70 to 140 kg/cm<sup>2</sup>.

(3) ***Hardness:***

In this test, a scratch is made on brick surface with the help of a finger nail. If no impression is left on the surface, brick is treated to be sufficiently hard.

(4) ***Presence of soluble salts:***

Soluble salts, if present in bricks, will cause efflorescence on the surface of bricks. For finding out the presence of soluble salts in a brick, it is immersed in water for 24 hours. It is then taken out and allowed to dry in shade. Absence of grey or white deposits on its surface indicates absence of soluble salts. If the white deposits cover about 10 per cent surface, the efflorescence is said to be slight and it is considered as moderate, when the white deposits cover about 50 per cent of surface. If grey or white deposits are found on more than 50 per cent of surface, the efflorescence becomes heavy and it is treated as serious, when such deposits are converted into powdery mass.

(5) ***Shape and size:***

In this test, a brick is closely inspected. It should be of standard size and its shape should be truly rectangular with sharp edges.

(6) ***Soundness:***

In this test, two bricks are taken and they are struck with each other. Bricks should not break and a clear ringing sound should be produced.

**(7) Structure:**

A brick is broken and its structure is examined. It should be homogeneous, compact and free from any defects such as holes, lumps, etc.

**Classification of bricks:**

Bricks used in construction works are classified into the following *four* categories:

- (1) First class bricks
- (2) Second class bricks
- (3) Third class bricks
- (4) Fourth class bricks.

**(1) First class bricks:**

These bricks are table-moulded and of standard shape. The surfaces and edges of the bricks are sharp, square and straight. They comply with all the qualities of good bricks which are mentioned earlier. These bricks are used for superior work of permanent nature.

**(2) Second class bricks:**

These bricks are ground-moulded and they are burnt in kilns. The surface of these bricks is somewhat rough and shape is also slightly irregular. These bricks are commonly used at places where brickwork is to be provided with a coat of plaster.

**(3) Third class bricks:**

These bricks are ground-moulded and they are burnt in clamps. These bricks are not hard and they have rough surfaces with irregular and distorted edges. These bricks give dull sound when struck together. They are used for unimportant and temporary structures and at places where rainfall is not heavy.

**(4) Fourth class bricks:**

These are overburnt bricks with irregular shape and dark colour. These bricks are used as aggregate for concrete in foundations, floors, roads, etc.

It is thus seen that the above classification of bricks is based on the method of manufacturing or preparing bricks.

### Colour of bricks:

Colour of bricks, as obtained in its natural course of manufacture, depends on the following factors:

- (1) degree of dryness achieved before burning,
- (2) natural colour of clay and its chemical composition,
- (3) nature of sand used in moulding operation,
- (4) quality of fuel used in burning operation,
- (5) quantity of air admitted to the kiln during burning, and
- (6) temperature at which bricks are burnt.

Table 3-2 shows the colours produced by clays with various constituents.

**TABLE 3-2**  
**COLOURS OF BRICKS**

Sr.No.	Colour	Constituents present in clay
1.	Black	Manganese and large proportion of iron
2.	Bluish green	Alkalies (burnt at high temperature)
3.	Bright red, dark blue or purple	Large amount of iron oxide
4.	Brown	Lime in excess
5.	Cream	Iron and little lime
6.	Red	Iron in excess
7.	White	Pure clay
8.	Yellow	Iron and magnesia

Artificial colouring of brick is achieved by adopting one of the following *two* methods:

- (1) Addition of colouring material
- (2) Dipping in colouring liquid.

#### **(1) Addition of colouring material:**

In this method, the required colouring material is added in brick earth. Bricks prepared from such earth will present the desired colour. Usual colouring materials are iron

oxide, manganese, French ultramarine, Indian red, etc. This method is adopted when the colouring material is cheap and when it is available in plenty.

### (2) *Dipping in colouring liquid:*

In this method, an earthenware box which is slightly larger each way than a common brick is taken. It is filled nearly to one half depth with liquid which is in the form of thick paste. Bricks to be coloured are placed on an iron plate and with a fire underneath, they are heated to such an extent that they can be easily handled. One brick is taken at a time and it is allowed to stay for few seconds in the box. It is then placed on a table to dry. Just after a few minutes, they are cleaned with cold water and placed aside to dry.

Colouring liquid is formed by the addition of colouring material to a mixture of linseed oil, litharge and turpentine. Table 3-3 shows the proportions of various components of colouring liquid for different colours.

**TABLE 3-3**  
COLOURING LIQUID

Component	Name of the colour			
	Black	Blue	Dark red	Grey
Linseed oil	120 gm.	570 c.c.	850 c.c.	60 gm.
Litharge	60 gm.	15 gm.	115 gm.	30 gm.
Turpentine	180 gm.	570 c.c.	850 c.c.	120 gm.
Manganese	180 gm.	—	—	30 gm.
French ultramarine	—	450 gm.	—	—
Indian red	—	—	15 gm.	—
White lead	—	—	—	90 gm.

Following are the *advantages* of this method:

- (i) Bricks which are coloured by this method do not lose their colour, when exposed to atmosphere.
- (ii) It can be adopted for expensive colours.
- (iii) It is possible to develop a variety of colours cheaply and easily.
- (iv) Penetration of colouring liquid in ordinary bricks is about 3 mm or so.

- (v) This method can also be used for brick walls which are already constructed. Wall surface is carefully cleaned. Colouring liquid is slightly heated and it is applied on wall surface with a brush.

### Size and weight of bricks:

Bricks are prepared in various sizes. Custom in the locality is the governing factor for deciding the size of a brick. If bricks are large, it is difficult to burn them properly and they become too heavy to be placed with a single hand. On the other hand, if bricks are small, more quantity of mortar is required. For India, a brick of size 19 cm  $\times$  9 cm  $\times$  9 cm is recommended. With mortar thickness, size of such a brick becomes 20 cm  $\times$  10 cm  $\times$  10 cm.

It is found that the weight of 1 m<sup>3</sup> of brick earth is about 1800 kg. Hence the average weight of a brick will be about 3 to 3.50 kg.

### Shape of bricks:

Ordinary bricks are rectangular solids. But sometimes bricks are given different shapes to make them suitable for particular type of construction. Following are some such shapes of bricks:

#### (1) *Bullnose brick:*

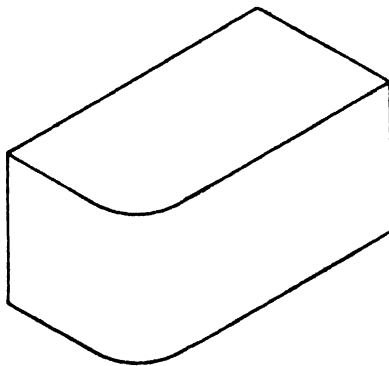

Bullnose brick

FIG. 3-8

A brick moulded with a rounded angle is termed as a bullnose. It is used for a rounded quoin. A connection

which is formed when a wall takes a turn is known as a quoin. The centre of the curved portion is situated on the long centre line of brick. Fig. 3-8 shows a bullnose brick.

(2) **Coping bricks:**

These bricks are made to suit the thickness of walls on which coping is to be provided. Such bricks take various forms such as chamfered, half-round or saddle-back as shown in fig. 3-9.

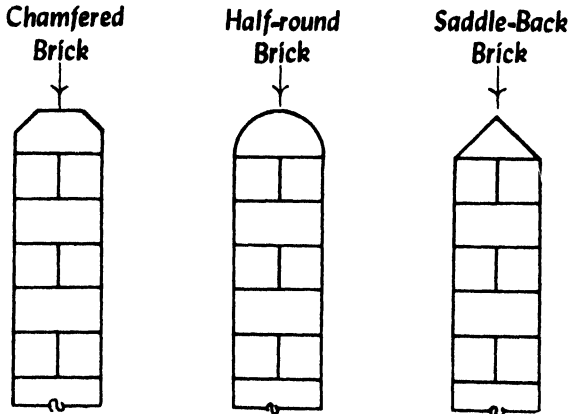

Brick copings

FIG. 3-9

(3) **Cownose bricks:**

A brick moulded with a double bullnose on end is known as a cownose.

(4) **Curved sector bricks:**

These bricks are in the form of curved sector and they are used in the construction of circular brick masonry pillars, brick chimneys, etc.

(5) **Hollow bricks:**

These are also known as *cellular* or *cavity bricks*. Such bricks have wall thickness of about 20 mm to 25 mm. They are prepared from special homogeneous clay. They are light in weight. They also reduce the transmission of heat, sound and damp. They are used in the construction of brick partitioning. Fig. 3-10 shows a typical hollow brick.

**(6) Paving bricks:**

These bricks are prepared from clay containing a higher percentage of iron. Excess iron vitrifies the bricks at a low temperature. Such bricks resist better the abrasive action of traffic. Paving bricks may be plain or chequered. Fig. 3-11 shows a chequered brick.

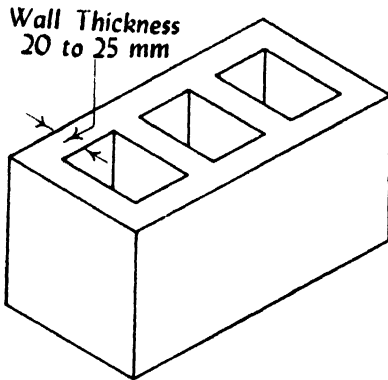

Hollow brick  
FIG. 3-10

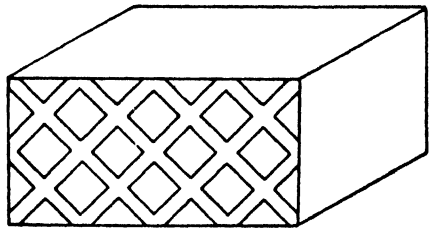

Chequered brick  
FIG. 3-11

**(7) Perforated bricks:**

These bricks contain cylindrical holes throughout their thickness as shown in fig. 3-12. These bricks are light in

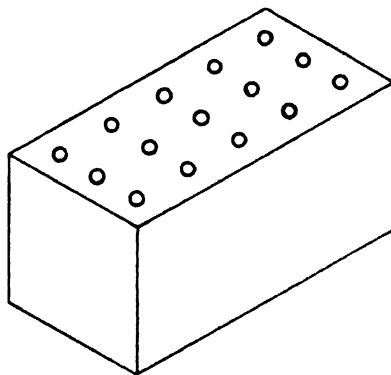

Perforated brick  
FIG. 3-12

weight and they require less quantity of clay for their preparation. Drying and burning of these bricks are also easy. If

perforated bricks of large size are used, it will result in the increase of output of mason. It has been observed that for tropical countries like India, bricks with perforations of about 30 to 45 per cent of the total area of the corresponding face of the brick would offer adequate thermal insulation property. Perforated bricks are used in the construction of brick panels for lightweight structures and multistoreyed framed structures.

The perforations may be circular, square, rectangular or any other regular shape in cross-section. The distance between the side of brick and edge of perforation should not be less than 15 mm. The distance between the edges of successive perforations should preferably be not less than 10 mm. The water absorption after immersion for 24 hours in water should not exceed 15 per cent by weight. The compressive strength of perforated bricks should not be less than 70 kg/cm<sup>2</sup> on gross area.

### (8) *Purpose-made bricks:*

In order to achieve certain purpose, these bricks are made. Splay or cant bricks are made for jambs of doors and windows. Arch bricks are made of wedge shape to keep mortar joint of uniform thickness. Ornamental bricks are prepared for corbels, cornices, etc. Engineering bricks having considerable strength, 500 to 800 kg/cm<sup>2</sup> and water absorption about 4 to 6 per cent, can be prepared from specially selected earth for use in constructions where high durability, compression strength and adequate resistance to sudden shocks are required.

### **Fire-clays:**

Fire-clay is a refractory clay which is capable of resisting a high temperature without being melted or softened. It is used for making refractory materials. A refractory material is able to stand a high temperature without losing its shape. Thus fire-clay is used in manufacture of fire-bricks, crucibles, lining materials for furnaces, hollow tiles, etc.

Earth that is available from under the coal seams is generally found to be good fire-clay. Constituents of a good fire-clay are *two*—alumina and silica. The percentages of alumina

varies from 25 to 35 and that of silica from 75 to 65. In any case, impurities such as lime, magnesia, iron oxide and alkalies should not exceed 5 per cent.

Depending upon the fire resisting capacity, fire-clays are classified into the following *three* categories:

- (1) High duty fire-clays
- (2) Medium duty fire-clays
- (3) Low duty fire-clays.

High duty fire-clays can resist temperature range of  $1482^{\circ}\text{C}$  to  $1648^{\circ}\text{C}$ ; medium duty fire-clays can resist temperature range of  $1315^{\circ}\text{C}$  to  $1482^{\circ}\text{C}$ , and low duty fire-clays can resist temperature upto  $870^{\circ}\text{C}$  only.

### **Fire-bricks:**

These bricks are made from fire-clay. Process of manufacture is the same as that of ordinary clay bricks. Burning and cooling of fire-bricks are done gradually.

These bricks are usually white or yellowish white in colour. Weight of a fire-brick is about 3 to 3.50 kg. Fire-bricks can resist high temperature without softening or melting. Hence, they are used for linings of furnaces and construction of boilers, chambers, chimneys, etc.

Following are the varieties of fire-bricks:

- (1) Acidic bricks
- (2) Basic bricks
- (3) Neutral bricks.

#### **(I) Acidic bricks:**

These bricks are used for acidic lining. Following are the types of acidic bricks:

##### **(i) Ordinary fire-bricks:**

These bricks are prepared from natural fire-clay and they provide a good material for acidic refractory lining.

(ii) *Silica bricks:*

These bricks contain a very high percentage of silica to the extent of about 95 to 97 per cent. A small quantity of lime, about 1 to 2 per cent, is added to work as binding material. These bricks are moulded under pressure and burnt at high temperature. Silica bricks can stand a high temperature upto about 2000°C.

(2) *Basic bricks:*

These bricks are used for basic lining and basic refractory materials are used in the manufacture of such bricks. Magnesia bricks are prepared from lime and magnesia rocks. Dolomite may also be adopted for the manufacture of these bricks.

(3) *Neutral bricks:*

These bricks are used for neutral lining. Following are the types of neutral bricks:

(i) *Chromite bricks:*

These bricks are prepared from a mixture of chrome, iron ore, ferrous oxide, bauxite and silica. Such bricks are unaffected by acidic or basic actions.

(ii) *High alumina bricks:*

These bricks contain a high percentage of alumina and they are found to be more inert to slags.

**Sand-lime or calcium silicate bricks:**

***Raw materials:***

Following raw materials are required for the preparation of sand-lime bricks:

- (1) Sand
- (2) Lime
- (3) Water
- (4) Pigment.

(1) *Sand:*

The percentage of sand in sand-lime bricks varies from 88 to 92 per cent. Hence the properties of sand-lime bricks are mainly governed by the characteristics of sand. For getting sand-lime bricks of good quality, sand should be well-graded and it should be free from impurities such as clays, organic matter, rock minerals, soluble salts, etc. Finely divided clay, if present in very small amount of less than 4 per cent, affords advantages of easier pressing, densification and smoother texture.

(2) *Lime:*

The percentage of lime in sand-lime bricks varies from 8 to 12 per cent. Lime should be of a high calcium lime of good quality. It should neither be overburnt nor underburnt.

(3) *Water:*

Water containing soluble salt or organic matter in excess of 0.25 per cent should not be used for the preparation of sand-lime bricks. Sea water is unfit for the manufacture of sand-lime bricks.

(4) *Pigment:*

To make coloured sand-lime bricks, suitable colouring pigment should be added in the mixture of sand and lime. The quantity of pigment varies from 0.2 to 3 per cent of the total weight of the brick. Table 3-4 shows pigments for getting sand-lime bricks of different colours.

**TABLE 3-4**  
**PIGMENTS FOR SAND-LIME BRICKS**

No.	Colour	Pigment
1.	Black	Carbon black
2.	Brown	Iron oxide
3.	Green	Chromium oxide
4.	Grey	Carbon black
5.	Red	Iron oxide
6.	Yellow	Ochra

**Manufacturing process:**

Following is the procedure of manufacturing sand-lime bricks:

- (1) Sand, lime and pigment are taken in suitable proportions and they are thoroughly mixed with 3 to 5 per cent of water.
- (2) The material is then moulded in the shape of bricks in a specially designed rotary table press under mechanical pressure. The material is in a semi-dry condition and the pressure varies from 315 to 630 kg per cm<sup>2</sup>.
- (3) Bricks are then placed in a closed chamber and subjected to saturated steam pressure of about 8.50 to 16.00 kg per cm<sup>2</sup> for 6 to 12 hours. This process is known as *autoclaving* or hydrothermal treatment. An autoclave is a steel cylinder with tightly sealed ends. Its diameter and length are respectively as 2 m and 20 m. The interaction between lime and sand is greatly speeded up by the rising temperature in the presence of high humidity.
- (4) Bricks are taken out of chamber and they can then be despatched for use.

**Advantages:**

Following are the *advantages* of sand-lime bricks:

- (1) If plaster is to be provided on sand-lime bricks, the quantity of mortar required will be less as bricks are uniform in size and shape.
- (2) The raw materials of these bricks do not contain any soluble salt. Hence the trouble of efflorescence does not arise.
- (3) These bricks are hard and strong.
- (4) These bricks are uniform in colour and texture.
- (5) These bricks can be prepared where clay is scarce. In other words, adoption of these bricks relieves pressure on agricultural land.

- (6) These bricks have accurate size and shape.
- (7) These bricks present a clean appearance and hence, plastering may be avoided.

### ***Disadvantages:***

Following are the *disadvantages* of sand-lime bricks:

- (1) These bricks are not suitable for furnace brickwork because they will disintegrate, if exposed to heat for a long time.
- (2) These bricks are weak in offering resistance to abrasion. Hence they cannot be used as paving material.
- (3) These bricks cannot be used for foundation work as they are less water resistant than clay bricks.
- (4) Where suitable clay for the manufacture of clay bricks is available in plenty, these bricks will prove to be uneconomical.

### ***Uses:***

Sand-lime bricks are used for ornamental work and they can be used in place of ordinary clay bricks in building industry. They are widely used in West Germany and Russia. They have yet not become popular in India except Kerala State where some structures are constructed with these bricks.

## QUESTIONS

1. Compare brickwork with stonework.
2. What are the constituents of good brick earth?
3. State the harmful ingredients in brick earth.
4. How is brick earth classified?
5. Discuss the operation of preparation of clay for the manufacture of bricks.

6. Write short notes on:
  - (1) Tempering
  - (2) Frog
  - (3) Ground-moulded bricks
  - (4) Tunnel kiln
  - (5) Classification of bricks
  - (6) Size and weight of bricks.
7. Describe the two ways of moulding of bricks.
8. How are bricks dried?
9. Discuss the process of burning bricks in clamps.
10. Describe the process of burning bricks in intermittent kilns.
11. Give sketches of the following:
  - (1) Pug mill
  - (2) Intermittent kiln
  - (3) Bull's trench kiln
  - (4) Hoffman's kiln
  - (5) Perforated brick.
12. Briefly describe the working of Bull's trench kiln for burning of bricks.
13. With the help of a neat sketch, explain the working of Hoffman's kiln for the burning of bricks.
14. Compare clamp-burning with kiln-burning.
15. Enumerate the qualities of good bricks.
16. Explain the tests to which bricks are generally subjected.
17. Write a critical note on the colour of bricks.
18. What are the different shapes in which bricks are formed?
19. Discuss the following:
  - (1) Fire-clays
  - (2) Fire-bricks
  - (3) Sand-lime bricks.
20. What are the raw materials used for the preparation of sand-lime bricks?
21. Describe the manufacturing process of sand-lime bricks.
22. Mention advantages, disadvantages and uses of sand-lime bricks.

23. Distinguish between the following:

- (1) Slop-moulded bricks and sand-moulded bricks
- (2) Clamp and kiln
- (3) Intermittent kiln and continuous kiln
- (4) Second class bricks and third class bricks
- (5) Bullnose brick and cownose brick
- (6) Acidic fire-bricks and basic fire-bricks
- (7) Ordinary bricks and fire-bricks
- (8) Loamy, chalky and strong clays
- (9) Blending and tempering
- (10) Hand moulding and machine moulding.

24. Give reasons for the following:

- (1) No lifting appliance is required for bricks.
- (2) Moulds are made longer by about 8 to 12 per cent in all directions.
- (3) A frog is placed on raw brick during moulding.
- (4) Bricks should be burnt properly.
- (5) The properties of sand-lime bricks are mainly governed by the characteristics of sand.
- (6) Sand-lime bricks cannot be used as paving material.
- (7) The top layer of soil, about 20 cm in depth, is to be rejected for the purpose of preparing bricks.
- (8) Tempering should be done exhaustively.
- (9) Strips of brass or steel are sometimes fixed on the edges of wooden moulds.
- (10) In brickwork, bricks are laid with frog uppermost.
- (11) Bricks are placed to stand on their longer sides in drying sheds.
- (12) Bricks produced in clamps are tough and strong.
- (13) Arch bricks are made of wedge shape.
- (14) If plaster is to be provided on sand-lime bricks, the quantity of mortar required will be less.
- (15) For sand-lime bricks, the trouble of efflorescence does not arise.
- (16) A small quantity of oxide of iron is desirable in good brick earth.

# Chapter 4

## LIME

### Some definitions:

Some of the important terms which will be used in this chapter are defined as follows:

#### (1) *Calcination:*

Heating to redness in contact with air is known as calcination.

#### (2) *Hydraulicity:*

It is the property of lime by which it sets or hardens in damp places, water or thick masonry walls where there is no free circulation of air.

#### (3) *Lime:*

Due to calcination of limestone, moisture and carbon dioxide are removed from it. Product which remains thereafter is known as lime. Its chemical composition is (CaO) oxide of calcium. The chemical reaction is as follows:

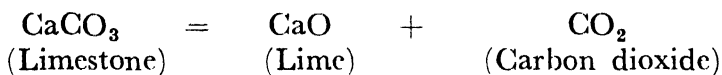

#### (4) *Quick lime:*

Lime which is obtained by the calcination of comparatively pure limestone is known as quick lime. Its chemical composition is (CaO) oxide of calcium and it has great affinity for moisture.

#### (5) *Setting:*

Process of hardening of lime after it has been converted into paste form is known as setting. It is quite different from mere drying. In case of drying, water evaporates only and no setting action takes place.

**(6) Slaked lime:**

Product obtained by slaking of quick lime is known as slaked lime. It is in the form of white powder and its chemical composition is  $\text{Ca}(\text{OH})_2$  or hydrated oxide of calcium. The chemical reaction is as follows:

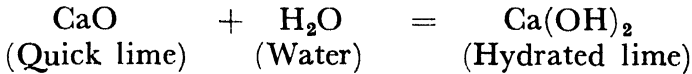

During the above reaction, a considerable amount of heat to the extent of about 15.6 k cal is released. The theoretical amount of water required for lime slaking is about 32% of the weight of  $\text{CaO}$ . But in practice, the amount of water required is about 2 to 3 times greater because of the composition of lime, degree of burning, method of slaking and mainly due to evaporation of the water by the released heat. The rate of slaking is affected by the size of lime lumps and temperature. It accelerates with the rise in temperature. It can be carried out very speedily by steam under pressure in closed drums.

**(7) Slaking:**

When water is added to quick lime in sufficient quantity, a chemical reaction takes place. Due to this chemical reaction, quick lime cracks, swells and falls into a powder form which is the calcium hydrate  $\text{Ca}(\text{OH})_2$  and it is known as hydrated lime. This process is known as slaking.

**Classification of binding materials:**

The binding materials can be broadly divided into *three* categories:

- (1) Air binding materials
- (2) Hydraulic binding materials
- (3) Autoclave binding materials.

**(1) Air binding materials:**

These are also known as air-setting binding substances and they pass into a stone state and then gain and retain their mechanical strength in the air only. Gypsum, acid-resistant cement, air-hardening or quick lime, etc. are the examples of air binding materials.

**(2) Hydraulic binding materials:**

These are also known as hydraulic-setting substances and they pass into a stone state and then gain and retain their mechanical strength not only in the air, but in water as well. Portland cement and its varieties, hydraulic lime, etc. are the examples of hydraulic binding materials. Such binding materials can be used for constructions above ground, below ground and under water.

**(3) Autoclave binding materials:**

These are also known as autoclave-setting substances and they set only when treated in autoclaves with saturated steam at pressures varying from 8 to 12 atmosphere and at temperatures between 170°C to 200°C. Lime-silica, sand portland cements, etc. are the examples of autoclave binding materials.

**Sources of lime:**

Lime is not usually available in nature in free state. It is procured by burning one of the following materials:

- (1) limestones from stone hills,
- (2) boulders of limestones from beds of old rivers,
- (3) kankar found below the ground, and
- (4) shells of sea animals.

It may be noted that white chalk is pure limestone and kankar is an impure limestone.

**Constituents of limestones:**

Main source of getting lime is limestones obtained from nature. Constituents of such limestones are as follows:

**(1) Clay:**

This constituent is responsible for producing hydraulicity in lime. It also makes lime insoluble in water. If it is in excess, it arrests slaking. If it is in small quantity, it retards slaking. A proportion of 8 to 30 per cent is desirable for making a good lime.

**(2) Soluble silica:**

It is essential to have silica and alumina present in chemical combination with limestone to develop hydraulicity. Silicates of calcium, magnesium and aluminium are responsible for hydraulicity. Such silicates are inert or inactive at low temperatures. But they become active and combine with lime at high temperatures.

**(3) Magnesium carbonate:**

Presence of this constituent allows lime to slake and set slowly. But it imparts more strength. Further, production of heat and expansion are less.

**(4) Alkalies and metallic oxides:**

When these are present in small amount upto about 5 per cent or so, they develop hydraulicity due to the formation of soluble silicates at low temperature.

**(5) Sulphates:**

Presence of sulphates in small quantities accelerates the process of setting and reduces slaking action.

**(6) Iron:**

If iron is present in small quantity, it develops a complex silicate at high temperature. But excess of iron is objectionable.

**(7) Pyrites:**

It is undesirable to have pyrites in the composition of limestones. Such limestones should therefore be rejected.

**Classification of limes:**

Limes which are obtained by calcination of limestones are broadly classified into *three* categories:

- (1) Fat lime
- (2) Hydraulic lime
- (3) Poor lime.

**(1) Fat lime:**

This lime is also known as *high calcium lime*, *pure lime*, *rich lime* or *white lime*. It is popularly known as *fat lime* as

it slakes vigorously and its volume is increased to about 2 to  $2\frac{1}{2}$  times the volume of quick lime. It is prepared by calcining comparatively pure carbonate of lime, which is composed of about 95 per cent of calcium oxide. Percentage of impurities in such limestone is less than 5 per cent.

Following are the *properties* of fat lime:

- (i) It hardens very slowly.
- (ii) It has a high degree of plasticity.
- (iii) It is soluble in water which is changed frequently.
- (iv) Its colour is perfectly white.
- (v) It sets slowly in presence of air.
- (vi) It slakes vigorously.

Following are the *uses* of fat lime:

- (i) It is used in whitewashing and plastering walls.
- (ii) With sand, it forms lime mortar which sets in thin joints. Such mortar can be used for thin joints of brickwork and stonework.
- (iii) With surkhi, it forms lime mortar which possesses good setting and hydraulic properties. Such mortar can be used for thick masonry walls, foundations, etc. Surkhi is the powder obtained by grinding of the burnt bricks.

## (2) *Hydraulic lime:*

This lime is also known as *water lime* as it sets under water. It contains clay and some amount of ferrous oxide. Depending upon the percentage of clay, hydraulic lime is divided into following *three* types:

- (i) Feebly hydraulic lime
- (ii) Moderately hydraulic lime
- (iii) Eminently hydraulic lime.

Table 4-1 shows the points of comparison between these types of hydraulic limes. Following facts should be noted:

- (1) Increase in percentage of clay makes the slaking difficult and increases the hydraulic property.
- (2) With about 30 per cent of clay, hydraulic lime resembles natural cement.

- (3) Hydraulic limes can set under water and in thick walls where there is no free circulation of air.
- (4) Colour of hydraulic lime is not perfectly white. It, therefore, appears less sanitary than fat lime.
- (5) It forms a thin paste with water. It does not dissolve in water though it is frequently changed.
- (6) If hydraulic lime is to be used for plaster work, it is to be ground in fine powder and then, it is mixed with sand. Mortar thus prepared is kept as heap for one week or so and it is then ground again. Such mortar can then be used for plaster works.

**TABLE 4-1**  
**HYDRAULIC LIMES**

Sr.No.	Item	Feebly hydraulic lime	Moderately hydraulic lime	Eminently hydraulic lime
1.	Clay content	5 to 10%	11 to 20%	21 to 30%
2.	Slaking action	Slakes after few minutes.	Slakes after one or two hours.	Slakes with difficulty.
3.	Setting action	Sets in water in 3 weeks or so.	Sets in water in one week or so.	Sets in water in a day or so.
4.	Hydraulicity	Feeble	Moderate	Eminent
5.	Uses	Mortar produced by this lime is reasonably strong and hence, it can be used for ordinary masonry work.	Mortar produc- ed by this lime is strong and hence, it can be used for super- ior type of masonry work.	Mortar produced by this lime is similar to ordinary cement and hence, it can be used for damp places.

### (3) *Poor lime:*

This lime is also known as *impure lime* or *lean lime*. It contains more than 30 per cent of clay. It slakes very slowly. It forms a thin paste with water. It does not dissolve in water though it is frequently changed. It sets or hardens very slowly.

This lime makes a very poor mortar. Such mortar can be used for inferior type of work or at places where good lime is not available.

### Comparison between fat lime and hydraulic lime:

There are mainly *two* varieties of limes, namely, fat lime and hydraulic lime. Table 4-2 shows the comparison of similar items for these two types of lime.

TABLE 4-2

COMPARISON BETWEEN FAT LIME AND HYDRAULIC LIME

Sr.No.	Item	Fat lime	Hydraulic lime
1.	Composition	It is obtained from comparatively pure carbonate of lime containing only 5 per cent of clayey impurities.	It is obtained from limestones containing clay to the extent of about 5 to 30 per cent and some amount of ferrous oxide.
2.	Slaking action	It slakes vigorously. Its volume is increased to about 2 to 2½ times the volume of quick lime. Slaking is accompanied by sound and heat.	It slakes slowly. Its volume is slightly increased. Slaking is not accompanied by sound or heat.
3.	Setting action	It sets slowly in presence of air. It absorbs carbon dioxide from atmosphere and forms calcium carbonate.	It sets under water. It combines with water and forms crystals of hydrated tricalcium aluminate and dicalcium silicate.
4.	Hydraulicity	It does not possess hydraulic property.	It possesses hydraulic property.
5.	Colour	It is perfectly white in colour.	Its colour is not so white as fat lime.
6.	Strength	It is not very strong. Hence, it cannot be used where strength is required.	It is strong and can, therefore, be adopted where strength is required.
7.	Uses	It is used for plastering, whitewashing, etc. and for preparing mortar with sand or surkhi.	It is used for preparing mortar for thick walls, damp places, etc. Extreme care is required to prepare mortar of this lime for plaster work.

**Manufacture of fat lime:**

Following *three* distinct operations are involved in the manufacture of fat lime:

- (1) Collection of limestones
- (2) Calcination of limestones
- (3) Slaking of burnt lime.

**(1) *Collection of limestones:***

Limestones of required quality are collected at site of work. For fat lime, percentage of impurities in limestones should not exceed 5 per cent. It is desirable to use comparatively pure carbonate of lime in the manufacturing process of fat lime.

**(2) *Calcination of limestones:***

Calcination or burning of limestones to bright red heat is the next important operation. Fuel required for calcination of limestones may consist of charcoal, coal, firewood or coal ashes. Initial firing is achieved with the help of few chips of dry wood or cow-dung cakes. As in case of bricks, burning of limestones can be achieved either in clamps or kilns. Clamps are temporary structures. Kilns are permanent structures and they may be of intermittent type or continuous type. Burning of limestones is thus carried out in one of the following:

- (i) Clamps
- (ii) Intermittent kilns
- (iii) Continuous kilns.

**(i) *Clamps:***

Ground is levelled and cleaned. Limestones and fuel are placed in alternate layers, if fuel is wood. But if fuel is of coal or charcoal, limestones and fuel are mixed together and placed in a heap form. Fig. 4-1 shows a typical clamp with dimensions as 6 m  $\times$  3.60 m  $\times$  3.60 m. Sloping sides are covered with mud plaster and attempt is thus made to preserve as much heat as possible. It is then fired from bottom.

Clamp burning is adopted to manufacture lime on a small scale because of its following *disadvantages*:

- (1) Clamp burning proves to be uneconomical to manufacture lime on a large scale.
- (2) Loss of heat is considerable. Mud plaster cracks by the heat from inside and allows heat to escape.
- (3) Quality of lime produced by clamp burning is not good.
- (4) Quantity of fuel required is more.

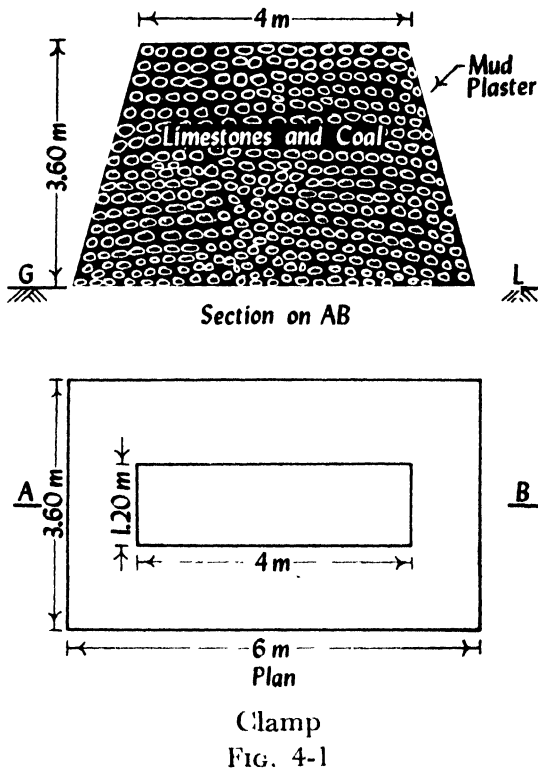

(ii) *Intermittent kilns*:

These are of various patterns and their sizes and shapes vary as per prevailing practice in the locality. Two important types of intermittent kilns will be discussed.

Fig. 4-2 shows the section of intermittent kiln in which alternate layers of limestone and fuel are arranged. Such a kiln is known as *intermittent flame kiln*. Horizontal and

vertical flues are suitably formed and top of kiln is covered with unburnt material. Kiln is ignited from bottom and limestones are allowed to burn for about 3 days or so. Kiln is then cooled and unloaded. Process is then repeated.

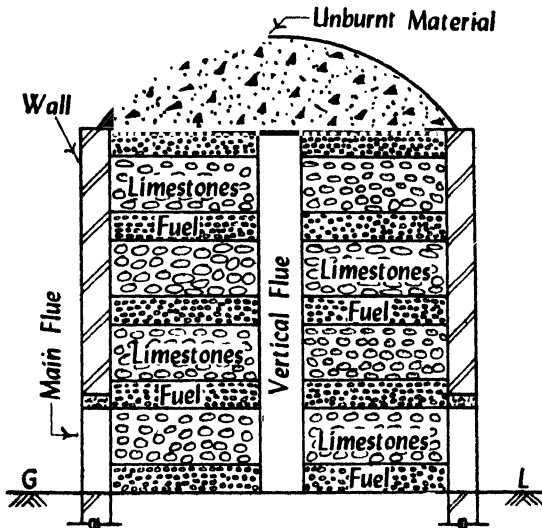

Intermittent flame kiln

FIG. 4-2

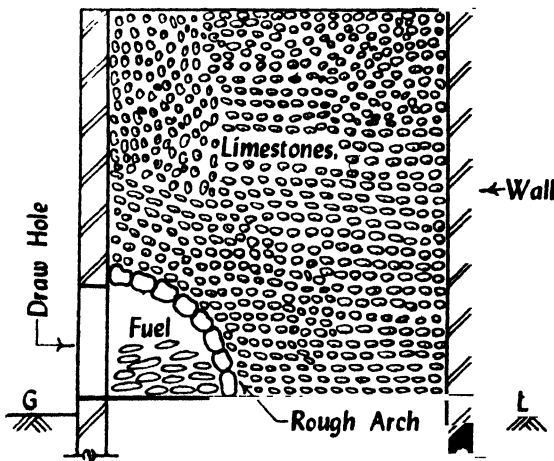

Intermittent flare kiln

FIG. 4-3

Fig. 4-3 shows the section of an intermittent kiln in which fuel is not allowed to come into contact with limestones.

A rough arch of selected big pieces of limestones is formed and smaller pieces of limestones are packed over this arch. Fuel is placed below the arch and when it is ignited, only flame comes into contact with limestones. Such a kiln is known as *intermittent flare kiln*. When limestones are sufficiently burnt, the kiln is cooled and unloaded. Process is then repeated. This type of kiln is easy to manage.

There is considerable wastage of time in intermittent kilns as every operation includes loading, burning, cooling and unloading. Supply of lime is also not continuously guaranteed. Hence such kilns are used to manufacture lime on moderate scale.

(iii) *Continuous kilns:*

These are also of various patterns and their sizes and shapes vary as per prevailing practice in the locality. Two important types of continuous kilns will be discussed.

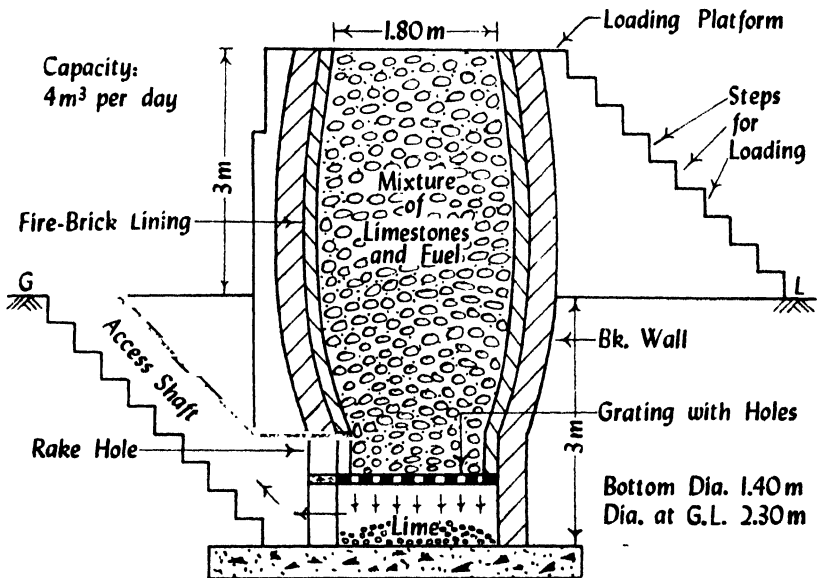

Continuous flame kiln

FIG. 4-4

Fig. 4-4 shows the section of continuous kiln in which mixture of limestones and fuel is fed from the top. Such a kiln is also known as *continuous flame kiln*. Fig. 4-4 shows

the continuous kiln of capacity about 4 m<sup>3</sup> per day. It is in the form of a cylinder with diameters at top, middle and bottom as about 1.80 m, 2.30 m and 1.40 m respectively. Widening of middle portion is done to accommodate hot gases of combustion. Bottom is covered by grating with holes. After burning, lime is collected at the bottom and it is removed through access shaft. Kiln is partly under the ground and partly above the ground. A loading platform is provided at the top. Inside surface of kiln is covered with fire-brick lining. To facilitate the fall of calcined particles, grating may be raked or cleaned through the rake hole. As the level of material in kiln falls, required quantity of mixture of limestones and fuel is fed from the top. A roof may be provided at the top to protect the kiln.

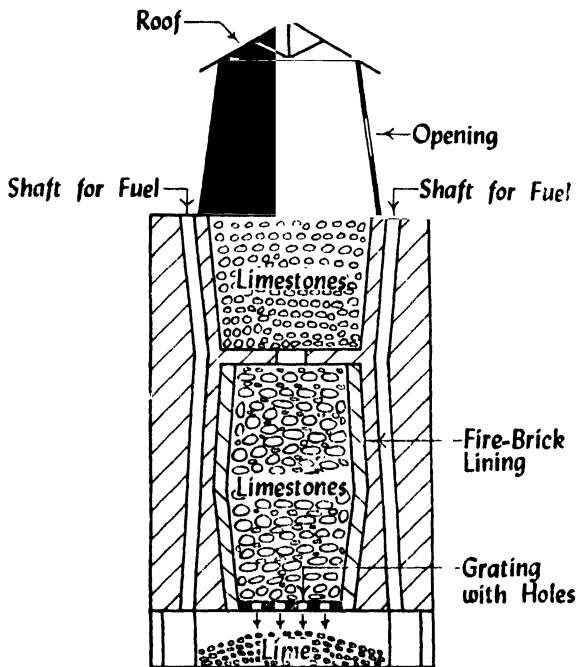

Continuous flare kiln

FIG. 4-5

Fig. 4-5 shows the section of continuous kiln in which fuel is not allowed to come into contact with limestones. It is also known as *continuous flare kiln*. This kiln consists of

*two* sections — upper and lower. Upper section serves as a storage of limestones. Lower portion is provided with fire-brick lining. While starting the kiln, a small quantity of fuel is mixed with limestone and ignited. Fuel is then fed through shafts around the upper and lower sections of kiln. Feeding of limestones is done from opening at top. Removal of calcined material is done through a grating placed at the bottom of kiln. A roof is provided at the top to protect the kiln.

There is considerable saving of time and fuel in case of continuous kilns. But the initial cost is high. Hence, these kilns are adopted to manufacture lime on a large scale.

Following facts should be remembered in the process of burning of limestones:

- (1) Bright red colour of stone indicates that the burning is complete.
- (2) Burning should be such that it does not result into over-burning or under-burning.
- (3) Heating should be gradual. Sudden heating results in the blowing of stones to pieces due to quick release of moisture and carbon dioxide.
- (4) Limestones should be broken into suitable sizes before they are burnt.
- (5) Quantity of fuel required in each case should be carefully decided.

### (3) *Slaking of burnt lime:*

Quick lime which is obtained by burning of limestones slakes when exposed to atmosphere. This is known as natural slaking or air slaking and it is a very slow process. Hence slaking is achieved by adding water to quick lime. Following are the *two* methods of slaking:

- (i) Slaking to paste
- (ii) Slaking to powder.

#### (i) *Slaking to paste:*

In this method, quick lime is spread in a layer of 15 cm depth in a wooden or masonry basin. Water in sufficient

quantity is then added so as to submerge quick lime. It is found that quantity of water required is about  $2\frac{1}{2}$  to 3 times the volume of quick lime. Excess water retards slaking and little water results in unsatisfactory slaking. Water should be added at a time and it should not be added after the temperature has risen. Basin is covered with wooden planks to preserve heat and to ensure proper slaking of the entire mass of quick lime. Stirring is not necessary and slaking is completed in about 10 minutes or so.

(ii) *Slaking to powder:*

In this method, quick lime is slaked to powder form. This may be achieved in one of the following *two* ways:

(1) Quick lime is broken into pieces of size not more than 50 mm. It is then carried in a basket and the basket is immersed in water for few seconds. It is then taken out and thrown on a wooden or masonry platform in a heap form. Quick lime crumbles and falls as powder form. Period for which basket is to be immersed in water is to be determined from experience.

(2) In this arrangement, quick lime is spread in layer of 15 cm depth on a wooden or masonry platform. Water is then sprinkled over this layer from a water-can or vessel fitted with a rose or perforated nozzle. Quick lime swells, crumbles and falls as powder form. This method is generally used to slake quick lime obtained from shells.

It is to be noted that over-burnt or under-burnt limestones do not slake easily. Hence such undesirable pieces should be removed before slaking. It is also necessary to convert all lumps into powder or pulp form. It is observed that one part of fat quick lime is converted into about  $1\frac{1}{2}$  parts in paste form and about 2 parts in powder form.

### **Manufacture of natural hydraulic lime:**

Following *three* distinct operations are involved in the manufacture of natural hydraulic lime:

- (1) Collection of kankar
- (2) Calcination of kankar
- (3) Slaking and grinding of burnt lime.

**(1) Collection of kankar:**

Kankar is an impure limestone and it is used for manufacturing natural hydraulic lime. Kankar is available in *two* forms, namely, nodular and block.

Nodules are found either on surface of ground or slightly below ground level. Nodules of kankar are easy to collect and kankar in nodular form is considered as superior material for manufacturing natural hydraulic lime for the following reasons:

- (i) It can withstand heat and rain without disintegration.
- (ii) It contains higher percentage of clay and hence, it possesses better hydraulic properties.

Blocks of kankar are found from the underground strata below the banks of rivers or streams.

Nodules or blocks of kankar are quarried with the help of pick-axes and crowbars. Such kankar is then cleaned of mud or earth and converted into suitable sizes.

**(2) Calcination of kankar:**

Calcination or burning of kankar to bright red heat is done either in clamps or kilns as in case of manufacture of fat lime.

**(3) Slaking and grinding of burnt lime:**

Slaking of hydraulic lime occurs very slowly. Hence, quick lime is first ground dry before water is added for slaking. Grinding of quick lime can be carried out in *one* of the following ways:

- (i) with hand with the help of wooden beaters, or
- (ii) with the help of mills working with bullocks or steam power, or,
- (iii) with the help of special machines.

Following points of differences in case of slaking of fat lime and hydraulic lime should be noted:

- (i) In case of fat lime, required quantity of water for slaking is added at a time. In case of hydraulic lime, water is added gradually to cause thorough slaking.

- (ii) One part of fat quick lime, when slaked, is converted into about  $1\frac{1}{2}$  parts in paste form and 2 parts in powder form. One part of hydraulic quick lime, when slaked, is converted into about 1 part in paste form and  $1\frac{1}{2}$  parts in powder form.
- (iii) Quantity of water required to slake fat lime is more than that required for hydraulic lime.
- (iv) Time taken by fat lime to slake is about 3 to 4 hours and that by hydraulic lime is about 12 to 48 hours.

### **Manufacture of artificial hydraulic lime:**

If natural raw material is not suitable for the manufacture of hydraulic lime, it is possible to prepare hydraulic lime artificially. In fact, fat lime may be converted into hydraulic lime by addition of clay in required proportion. Following are the *two* methods of preparing artificial hydraulic lime:

- (1) Conversion of soft limestone
- (2) Conversion of hard limestone.

#### **(1) Conversion of soft limestone:**

The available limestone, if of soft quality such as chalk, is ground and converted into powder form. It is mixed with the required proportion of clay. It is then burnt in a kiln and slaking is carried out as in case of manufacture of natural hydraulic lime.

#### **(2) Conversion of hard limestone:**

The available limestone, if of hard quality, is first burnt and slaked. To this slaked lime, required proportion of clay is added to obtain raw material for good variety of hydraulic lime. This mixture is converted into balls of suitable size and after drying, these balls are burnt in kiln. Slaking is carried out as in case of manufacture of natural hydraulic lime. As this lime is produced after burning twice in kiln, it is also known as *twice-kilned lime*.

**Tests for limestones:**

Limestones are tested to determine the quality of lime which can be obtained from them. For determining exactly the suitability of limestone, detailed chemical tests are carried out in a laboratory. But for general information, the following practical tests are made:

- (1) Physical properties
- (2) Heat test
- (3) Acid test.

**(1) Physical properties:**

Pure limestone is indicated by white colour. Hydraulic limestones are indicated by bluish grey, brown or some dark colour. Taste of hydraulic limestones is clayey and they give out earthy smell. Presence of glistening particles on the surface of limestones indicates the presence of free sand.

**(2) Heat test:**

A piece of dry limestone is weighed and it is heated in an open fire for few hours. Sample is weighed again and loss of weight indicates the amount of carbon dioxide. From this data, amount of calcium carbonate in limestone is worked out.

**(3) Acid test:**

Specimen of limestone is taken and dilute hydrochloric acid is poured on it. If content of calcium carbonate is high, there will be vigorous effervescence and less formation of residue. Such an action will indicate pure limestone. On the other hand, if content of calcium carbonate is less, there will be less effervescence and more formation of residue. Such an action will indicate impure or hydraulic limestone.

**QUESTIONS**

1. Define the following:  
Calcination; Lime; Setting; Slaked lime.
2. Enumerate the sources of lime.

3. What are the constituents of limestones?
4. Write short notes on:
  - (1) Poor lime
  - (2) Clamps for limestone burning
  - (3) Slaking to paste
  - (4) Hydraulic limes
  - (5) Intermittent flare kiln
  - (6) Continuous flare kiln.
5. Explain the classification of limes.
6. Compare fat lime with hydraulic lime.
7. How is fat lime manufactured?
8. Give a sketch of a continuous flame kiln and explain its working.
9. How is natural hydraulic lime manufactured?
10. Describe the methods of slaking burnt lime.
11. What is meant by artificial hydraulic lime? How is it manufactured?
12. Briefly describe the practical tests for limestones.
13. How are binding materials classified?
14. Give sketches of the following:
  - (1) Clamp
  - (2) Continuous flame kiln
  - (3) Continuous flare kiln.
15. Distinguish between the following:
  - (1) Quick lime and slaked lime
  - (2) Feebly hydraulic lime and eminently hydraulic lime
  - (3) Fat lime and poor lime
  - (4) Intermittent flame kiln and intermittent flare kiln
  - (5) Hydraulic binding materials and air binding materials
  - (6) Hydrated lime and hydraulic lime.
16. Give reasons for the following:
  - (1) Hydraulic lime appears less sanitary than fat lime.
  - (2) There is considerable wastage of time in intermittent kilns.
  - (3) Kankar in modular form is considered as superior material for manufacturing natural hydraulic lime.
  - (4) The actual amount of water required for lime slaking is more than the theoretical requirement.

# Chapter 5

## CEMENT

### Definition:

Natural cement is obtained by burning and crushing the stones containing clay, carbonate of lime and some amount of carbonate of magnesia. Clay content in such stones is about 20 to 40 per cent. Natural cement is brown in colour and its best variety is known as *Roman Cement*. Natural cement resembles very closely eminent hydraulic lime. It sets very quickly after addition of water. It is not so strong as artificial cement and hence, it has limited use in practice.

Artificial cement is obtained by burning at a very high temperature a mixture of calcareous and argillaceous materials. Mixture of ingredients should be intimate and they should be in correct proportion. Calcined product is known as clinker. A small quantity of gypsum is added to clinker and it is then pulverised into very fine powder which is known as *cement*. Common variety of artificial cement is known as normal setting cement or ordinary cement. This cement was invented by a mason Joseph Aspdin of Leeds in England in 1824. After setting, this cement closely resembles a variety of sandstone which is found in abundance in Portland in England. It is, therefore, sometimes referred to as *Portland cement*.

Various varieties of artificial cements are available in the market at present. We will first concentrate our attention on the study of normal setting or ordinary or Portland cement. Other varieties of artificial cement will be described subsequently.

### Cement and lime:

Following points of differences may be noted between ordinary cement and lime:

- (1) Cement can be used under conditions and circumstances which are not favourable for lime.

- (2) Cement, when converted into a paste form, sets quickly.
- (3) Colours of cement and lime are different.
- (4) When water is added to cement, no heat is produced and there is no slaking action.

### Composition of ordinary cement:

Ordinary cement contains *two* basic ingredients, namely, argillaceous and calcareous. In argillaceous materials, clay predominates and in calcareous materials, calcium carbonate predominates. A typical chemical analysis of a good ordinary cement is as follows:

Ingredient	Per cent
Lime (CaO) .....	62
Silica (SiO <sub>2</sub> ).....	22
Alumina (Al <sub>2</sub> O <sub>3</sub> ).....	5
Calcium sulphate (CaSO <sub>4</sub> ).....	4
Iron oxide (Fe <sub>2</sub> O <sub>3</sub> ) .....	3
Magnesia (MgO).....	2
Sulphur (S) .....	1
Alkalies .....	1
Total	100

### Functions of cement ingredients:

Ingredients of ordinary cement, as mentioned above, perform the following functions:

#### (1) *Lime (CaO):*

This is the important ingredient of cement and its proportion is to be carefully maintained. Lime in excess makes the cement unsound and causes the cement to expand and disintegrate. On the other hand, if lime is in deficiency, strength of cement is decreased and it causes cement to set quickly.

#### (2) *Silica (SiO<sub>2</sub>):*

This is also an important ingredient of cement and it gives or imparts strength to cement.

(3) **Alumina** ( $Al_2O_3$ ):

This ingredient imparts quick setting property to cement. Alumina in excess weakens the cement.

(4) **Calcium sulphate** ( $CaSO_4$ ):

This ingredient is in the form of gypsum and its function is to increase the initial setting time of cement.

(5) **Iron oxide** ( $Fe_2O_3$ ):

This ingredient imparts colour, hardness and strength to cement.

(6) **Magnesia** ( $MgO$ ):

This ingredient, if present in small amount, imparts hardness and colour to cement.

(7) **Sulphur** ( $S$ ):

A very small amount of sulphur is useful in making sound cement. If it is in excess, it causes cement to become unsound.

(8) **Alkalies**:

Most of the alkalies present in raw materials are carried away by the flue gases during heating and cement contains only a small amount of alkalies. If they are in excess in cement, efflorescence is caused.

**Harmful constituents of cement:**

The presence of the following *two* oxides adversely affects the quality of cement:

- (1) Alkali oxides  $K_2O$  and  $Na_2O$
- (2) Magnesium oxide  $MgO$ .

If the amount of alkali oxides exceeds 1 per cent, it leads to the failure of concrete made from that cement. Similarly, if the content of magnesium oxide exceeds 5 per cent, it causes cracks after mortar or concrete hardens. It is due to the fact that magnesium oxide, burned at a temperature of about  $1500^\circ C$ , slakes very slowly, when mixed with water.

### Setting action of cement:

When water is added to cement, ingredients of cement react chemically with water and form various complicated chemical compounds. Formation of these compounds is not simultaneous. But setting action of cement continues for a long time. It is found that ordinary cement achieves about 70% of its final strength in 28 days and about 90% of its final strength in one year or so. Following are the important compounds formed during the setting action of cement:

(1) *Tricalcium aluminate* ( $3\text{CaO}, \text{Al}_2\text{O}_3$ ):

This compound is formed within about 24 hours after addition of water to cement.

(2) *Tetra-calcium alumino-ferrite* ( $4\text{CaO}, \text{Al}_2\text{O}_3, \text{Fe}_2\text{O}_3$ ):

This compound is also formed within about 24 hours after addition of water to cement.

(3) *Tricalcium silicate* ( $3\text{CaO}, \text{SiO}_2$ ):

This compound is formed within a week or so after addition of water to cement and it is mainly responsible for imparting strength to cement in early period of setting.

(4) *Dicalcium silicate* ( $2\text{CaO}, \text{SiO}_2$ ):

This compound is formed very slowly and hence, it is responsible for giving progressive strength to cement.

The above *four* principle minerals in ordinary portland cement are designated in short as  $\text{C}_3\text{A}$ ,  $\text{C}_4\text{AF}$ ,  $\text{C}_3\text{S}$  and  $\text{C}_2\text{S}$  respectively and their relative proportions, expressed as percentages, are as follows:

$\text{C}_3\text{A}$	..... 4 to 14	} (celit)
$\text{C}_4\text{AF}$	..... 10 to 18	
$\text{C}_3\text{S}$	..... 45 to 65	(alit)
$\text{C}_2\text{S}$	..... 15 to 35	(belit)

When water is added to cement, the quickest to react with water is  $\text{C}_3\text{A}$  and in order of decreasing rate are  $\text{C}_4\text{AF}$ ,  $\text{C}_3\text{S}$  and  $\text{C}_2\text{S}$ . During the initial period of hardening, the gain in strength of  $\text{C}_2\text{S}$  is small and it is about 15 per cent of that of  $\text{C}_3\text{S}$ . After 28 days, the hydration of  $\text{C}_3\text{S}$  comes practically to an end and the hydration of  $\text{C}_2\text{S}$  only really begins

at that time. Hence when a high-strength concrete is required within a short period of time, cement is made with a high content of  $C_3S$ . On the other hand, if a high-strength concrete is required at a later stage, as in case of hydraulic engineering constructions, cement is made with a high content of  $C_2S$ . The hardening of concrete is greatly speeded by up  $C_3A$  and hence, this property of  $C_3A$  is utilised for producing quick-hardening portland cement.

Depending upon the mineralogical composition of clinker in percentage, portland cement can be subdivided conventionally as follows:

- Alit, containing  $C_3S$  more than 50 to 60%.
- Aluminate, containing  $C_3A$  more than 12%.
- Alumoferrite, containing  $C_3A$  less than 2% and  $C_4AF$  more than 18%.
- Belit, containing  $C_2S$  more than 35%.
- High-alit, containing  $C_3S$  more than 60%.

### **Site for cement factory:**

Location of cement factory should be decided carefully. Following are the guiding factors which are to be paid attention to while making selection for site of a proposed cement factory:

#### **(1) Climatic conditions:**

Site for cement factory should be selected in such a way that its climatic conditions are favourable for the manufacturing process of cement.

#### **(2) Labour:**

Site should be such that it is possible to procure the required labour easily and economically.

#### **(3) Market:**

Site for cement factory should be, as far as possible, near to the market of sale. This will decrease the cost of transport and minimise the chances of spoiling the cement during transport.

#### **(4) Power:**

Availability of power and fuel at economic rates should also be considered.

(5) **Raw materials:**

These should be available easily and continuously around the area of site under consideration.

(6) **Transport facilities:**

Site for a cement factory should be such that transport facilities are available for raw materials and finished products.

(7) **Miscellaneous:**

It is necessary to have parks, gardens, recreation centres, etc. near the site for a cement factory. Such arrangements would be helpful for giving relaxation to officers and workers of the factory.

It may be mentioned that the above conditions are meant for an ideal site for cement factory. It is difficult, if not impossible, to obtain such a site in practice. It, therefore, becomes necessary to select a site which satisfies most of the conditions mentioned above.

**Manufacture of ordinary cement:**

Following *three* distinct operations are involved in the manufacture of normal setting or ordinary or portland cement:

- (1) Mixing of raw materials
- (2) Burning
- (3) Grinding.

(1) **Mixing of raw materials:**

Raw materials such as limestone or chalk and shale or clay may be mixed either in dry condition or in wet condition. Process is accordingly known as dry process or wet process of mixing.

*Dry process:*

In this process, the raw materials are first reduced in size of about 25 mm in crushers. A current of dry air is then passed over these dried materials. These dried materials are then pulverised into fine powder in ball mills and tube mills. All these operations are done separately for each raw material and they are stored in hoppers. They are then mixed in correct proportions and made ready for the feed of rotary kiln. This finely ground powder of raw

materials is known as *raw mix* and it is stored in storage tank. Fig. 5-1 shows the flow diagram of mixing of raw materials by dry process:

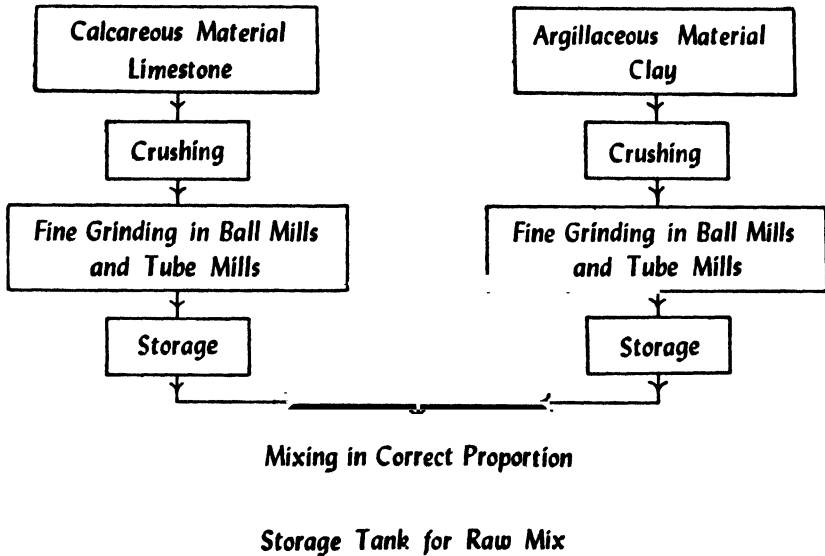

Flow diagram of dry process  
FIG. 5-1

Dry process is adopted when raw materials are hard. But the process is slow and it proves to be costly. Further, cement produced is of inferior quality to that produced by wet process. Hence this process has been practically replaced at present by wet process of mixing of raw materials. However, the dry process possesses the following *advantages*:

- (1) It increases the productivity of labour.
- (2) The capital required for the manufacture of tonne of cement is less.
- (3) The fuel consumption is reduced.

#### *Wet process:*

In this process, calcareous materials such as limestone are crushed and stored in silos or storage tanks. Argillaceous material such as clay is thoroughly mixed with water in a container known as *wash mill*. This washed clay is stored in basins. Now, crushed limestone from silos and wet clay from basins are allowed to fall in a channel in correct propor-

tions. This channel leads the materials to grinding mills where they are brought into intimate contact to form what is known as *slurry*. Grinding is carried out either in ball mill or tube mill or both. The slurry is led to correcting basin where it is constantly stirred. At this stage, the chemical composition is adjusted as necessary. The corrected slurry is stored in storage tanks and kept ready to serve as feed for rotary kiln. Fig. 5-2 shows the flow diagram of mixing of raw materials by wet process.

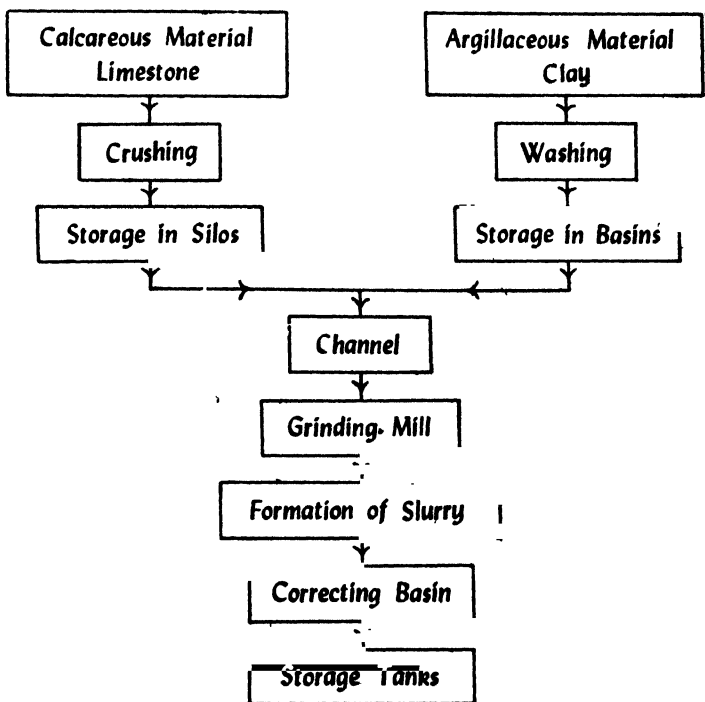

Flow diagram of wet process

FIG. 5-2

It is thus seen that in case of mixing of raw materials by dry process, raw mix is formed and in case of mixing of raw materials by wet process, slurry is formed. The remaining *two* operations, namely, burning and grinding, are the same for both the processes.

## (2) **Burning:**

Burning is carried out in a rotary kiln as shown in fig. 5-3. A rotary kiln is formed of steel tubes. Its diameter varies

from 250 cm to 300 cm. Its length varies from 90 m to 120 m. It is laid at a gradient of about 1 in 25 to 1 in 30. The kiln is supported at intervals by columns of masonry or concrete. Refractory lining is provided on the inside surface of rotary kiln. It is so arranged that the kiln rotates once in every minute about its longitudinal axis.

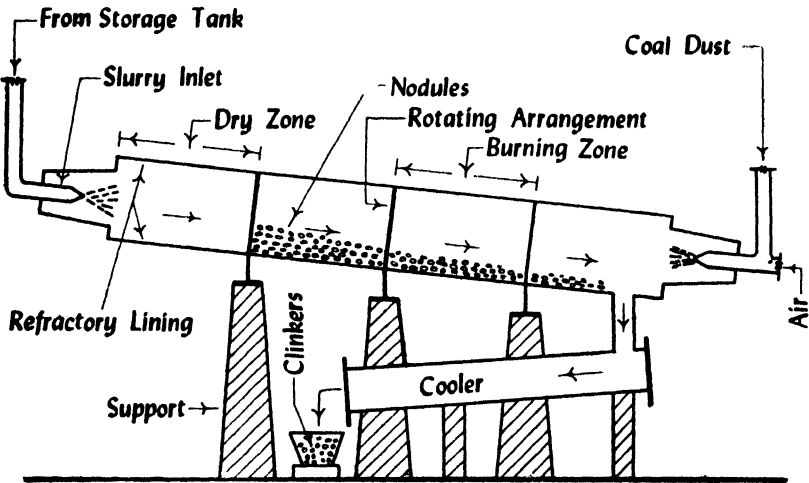

Rotary kiln

FIG. 5-3

The corrected slurry is injected at the upper end of kiln as shown in fig. 5-3. Hot gases or flames are forced through the lower end of kiln. Portion of the kiln near its upper end is known as *dry zone* and in this zone, water of slurry is evaporated. As the slurry gradually descends, there is rise in temperature and in the next section of kiln, carbon dioxide from slurry is evaporated. Small lumps, known as *nodules*, are formed at this stage. These nodules then reach to the burning zone where temperature is about  $1500^{\circ}\text{C}$  to  $1700^{\circ}\text{C}$ . In burning zone, calcined product is formed and nodules are converted into small hard stones which are known as *clinkers*.

The size of clinkers varies from 5 mm to 10 mm and they are very hot when they come out of burning zone of kiln. A rotary kiln of small size is provided to cool down the hot clinkers. It is laid in opposite direction as shown in fig. 5-3 and the cooled clinkers are collected in containers of suitable sizes.

### (3) *Grinding:*

Clinkers as obtained from the rotary kiln are finely ground in ball mills and tube mills. During grinding, a small quantity, about 3 to 4 per cent, of gypsum is added. Gypsum controls the initial setting time of cement. If gypsum is not added, cement would set as soon as water is added. Gypsum acts as a retarder and it delays the setting action of cement. It thus permits cement to be mixed with the aggregates and to be placed in position. The finely ground cement is stored in silos. It is then weighed and packed in bags by automatic machine. Each bag of cement contains 50 kg or about 0.035 m<sup>3</sup> of cement. These bags are carefully stored in a dry place. Fig. 5-4 shows the flow diagram of burning and grinding operations.

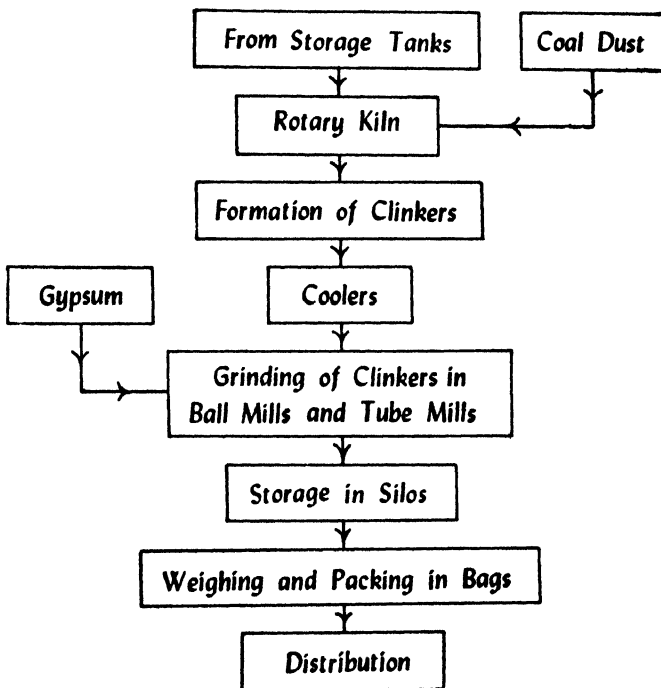

Flow diagram of burning and grinding operations of cement

FIG. 5-4

### **Ball mills and tube mills:**

These mills are used to carry out grinding of raw materials or mixture of raw materials or clinkers. Ball mills are used

to have preliminary grinding and tube mills are used to carry out final grinding.

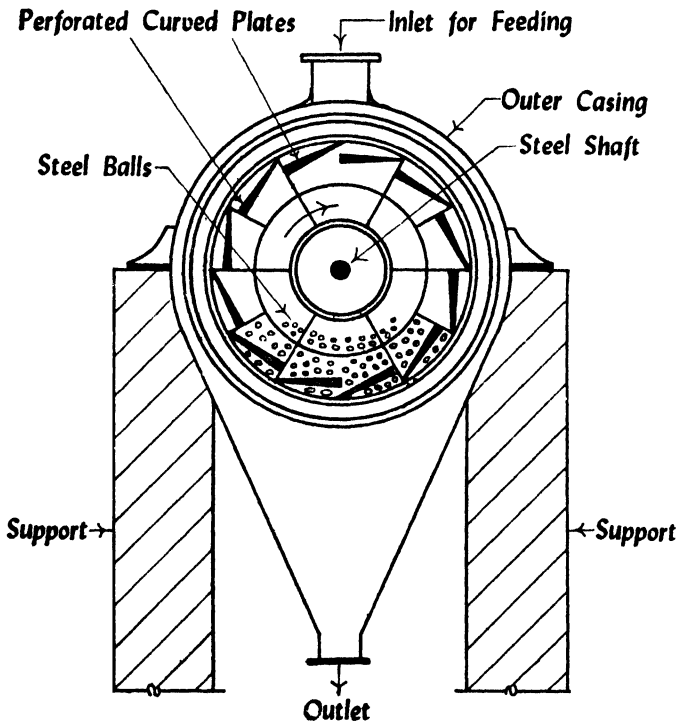

Vertical section of a ball mill

FIG. 5-5

Fig. 5-5 shows the vertical section of a typical ball mill. It is in the form of steel cylinder of diameter about 200 cm to 250 cm and of length about 180 cm to 200 cm. The cylinder is placed in a horizontal position and it rotates around a steel shaft. On the inside of cylinder, perforated curved plates are fixed. Ends of these plates overlap each other. The cylinder is filled partly with steel balls of size varying from 50 mm to 120 mm. The action of ball mill is very simple. The material to be ground is fed from the top. When the mill is rotated about its horizontal axis, the steel balls strike against the perforated curved plates and in doing so, they crush the material. This crushed material passes through an inner sieve plate and then through an outer sieve plate.

It is collected from an outlet at the bottom of outer casing of mill.

Fig. 5-6 shows the longitudinal section of a typical tube mill. It is in the form of a long horizontal steel cylinder of diameter about 150 cm and of length about 7 m to 10 m. The cylinder is filled partly with steel balls of size varying from 20 mm to 25 mm. The action of tube mill is similar to that of ball mill. But fine grinding is achieved due to steel balls of smaller size. A worm is provided to feed the material to the mill. The pulverised material is collected at the outlet funnel. In case of large scale production, air separators may be employed to separate finely ground particles. In this arrangement, current of air is used to carry away the finely pulverised particles.

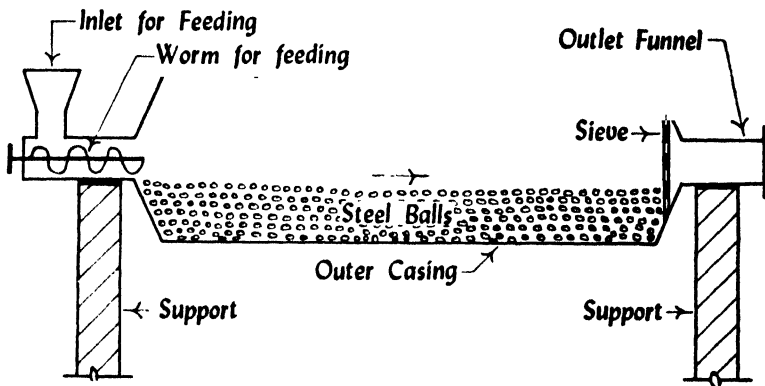

Longitudinal section of a tube mill

FIG. 5-6

To combine preliminary and final grinding, compartment mill or multiple chamber mill may be adopted. Such a mill has different chambers or sections in which steel balls of different sizes are placed. The material to be ground is allowed to pass through chambers in succession. Chambers with steel balls of bigger size are placed first and they are followed by chambers having steel balls of smaller size. It is thus seen that a compartment mill combines the actions of ball mill and tube mill. It results in saving of floor space and it simplifies the grinding process. Cost of grinding also works out to be less by the installation of such a mill.

**Field tests for cement:**

Following field tests may be carried out to ascertain roughly the quality of cement:

- (1) Colour
- (2) Physical properties
- (3) Presence of lumps
- (4) Strength.

**(1) Colour:**

The colour of cement should be uniform. It should be typical cement colour, i.e., grey colour with a light greenish shade.

**(2) Physical properties:**

Cement should feel smooth when touched or rubbed in between fingers. If it is felt rough, it indicates adulteration with sand. If hand is inserted in a bag or heap of cement, it should feel cool. If a small quantity of cement is thrown in a bucket of water, it should sink and should not float on the surface.

**(3) Presence of lumps:**

Cement should be free from any hard lumps. Such lumps are formed by the absorption of moisture from the atmosphere. Any bag of cement containing such lumps should be rejected.

**(4) Strength:**

Strength of cement can roughly be ascertained by making briquettes with a lean or weak mortar. The size of briquette may be about 75 mm × 25 mm × 12 mm. Proportion of cement and sand may be 1:6. The briquettes are immersed in water for a period of 3 days. If cement is of sound quality, such briquettes will not be broken easily and it will be difficult to convert them into powder form.

**Laboratory tests for cement:**

Exhaustive tests are carried out in laboratory to decide precisely the quality of cement. Following are the standard tests for cement:

- (1) Chemical composition
- (2) Fineness
- (3) Compressive strength
- (4) Tensile strength
- (5) Consistency.
- (6) Setting times
- (7) Soundness.

A brief description of each test is given below:

**(1) Chemical composition:**

Various tests are carried out to determine the chemical constituents of cement. Following are the chemical requirements of ordinary cement.

(i) *Ratio of percentage of alumina to that of iron oxide:* This ratio should not be less than 0.66.

(ii) *Ratio of percentage of lime to those of alumina, iron oxide and silica:* This ratio should not be less than 0.66 and it should not be greater than 1.02.

(iii) *Total loss on ignition:* This should not be greater than 4 per cent.

(iv) *Total sulphur content:* Sulphur content is calculated as  $\text{SO}_3$  and it should not be greater than 2.75 per cent.

(v) *Weight of insoluble residue:* This should not be greater than 1.50 per cent.

(vi) *Weight of magnesia:* This should not exceed 5 per cent.

**(2) Fineness:**

This test is carried out to check proper grinding of cement. Fineness of cement particles may be determined either by sieve test or by permeability apparatus test.

In sieve test, cement weighing 100 gm is taken and it is continuously passed for 15 minutes through standard IS sieve No. 9. The residue is then weighed and this weight should not be more than 10 per cent of original weight.

In permeability apparatus test, specific surface area of cement particles is calculated. This test is better than sieve test and it gives an idea of uniformity of fineness.

Specific surface acts as a measure of the frequency of particles of average size. Specific surface of cement should not be less than  $2250 \text{ cm}^2/\text{gm}$ .

### (3) *Compressive strength:*

This test is carried out to determine the compressive strength of cement. Following procedure is adopted:

(i) Mortar of cement and sand is prepared. Proportion is 1:3 which means that  $x$  gm of cement is mixed with  $3x$  gm of sand.

(ii) Water is added to the mortar. Water cement ratio is kept as 0.4 which means that  $0.4x$  gm of water is added to dry mortar.

(iii) The mortar is placed in moulds. Test specimens are in the form of cubes with side as 70.6 mm or 76 mm. Moulds are of metal and they are constructed in such a way that specimens can be easily taken out without being damaged. For 70.6 mm and 76 mm cubes, cement required is 185 gm and 235 gm respectively.

(iv) The mortar, after being placed in the moulds, is compacted in vibrating machine for 2 minutes.

(v) The moulds are placed in a damp cabin for 24 hours.

(vi) The specimens are removed from the moulds and they are submerged in clean water for curing.

(vii) The cubes are then tested in compression testing machine at the end of 3 days and 7 days. Testing of cubes is carried out on their three sides without packing. Thus three cubes are tested each time to find out the compressive strength at the end of 3 days and 7 days. Average value is then worked out. During the test, load is to be applied uniformly at the rate of  $350 \text{ kg/cm}^2$ .

(viii) Compressive strength at the end of 3 days should not be less than  $115 \text{ kg/cm}^2$  and that at the end of 7 days should not be less than  $175 \text{ kg/cm}^2$ .

### (4) *Tensile strength:*

This test was formerly used to have an indirect indication of compressive strength of cement. It is at present

generally used for rapid hardening cement. Following procedure is adopted:

(i) Mortar of cement and sand is prepared. Proportion is 1:3 which means that  $x$  gm of cement is mixed with  $3x$  gm of sand.

(ii) Water is added to the mortar. Quantity of water is 8 per cent by weight of cement and sand.

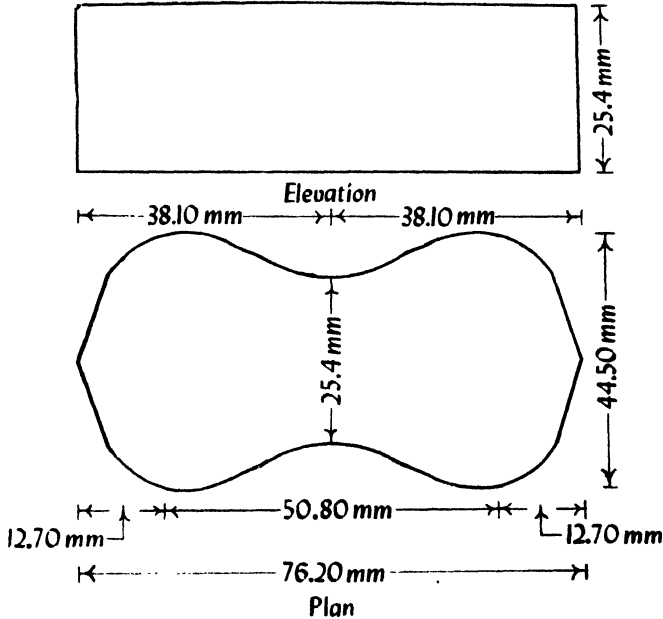

Standard briquette

FIG. 5-7

(iii) The mortar is placed in briquette moulds. A typical briquette is shown in fig. 5-7. Mould is filled with mortar and then a small heap of mortar is formed at its top. It is beaten down by a standard spatula till water appears on the surface. Same procedure is repeated for the other face of briquette. Twelve such standard briquettes are prepared. Quantity of cement may be 600 gm for 12 briquettes.

(iv) The briquettes are kept in a damp cabin for 24 hours.

(v) The briquettes are carefully removed from the moulds and they are submerged in clean water for curing.

(vi) The briquettes are tested in testing machine at the end of 3 days and 7 days. Six briquettes are tested in each test and average is found out. During the test, load is to be applied uniformly at the rate of 35 kg/cm<sup>2</sup>.

(vii) It may be noted that cross-sectional area of briquette at its least section is 6.45 cm<sup>2</sup>. Hence, ultimate tensile stress of cement paste is obtained from the following relation:

$$\text{Ultimate tensile stress} = \frac{\text{failing load}}{6.45}$$

(viii) Tensile stress at the end of 3 days should not be less than 20 kg/cm<sup>2</sup> and that at the end of 7 days should not be less than 25 kg/cm<sup>2</sup>.

#### (5) **Consistency:**

The purpose of this test is to determine the percentage of water required for preparing cement pastes for other tests. Following procedure is adopted:

(i) Take 300 gm of cement and add 30 per cent by weight or 90 gm of water to it.

(ii) Mix water and cement on a non-porous surface. Mixing should be done thoroughly.

(iii) Fill the mould of Vicat apparatus. The interval between the addition of water to the commencement of filling the mould is known as time of gauging and it should be  $3\frac{3}{4}$  to  $4\frac{1}{4}$  minutes.

(iv) Vicat apparatus is shown in fig. 5-8. It consists of a frame to which is attached a movable rod. An indicator is attached to the movable rod. This indicator moves on a vertical scale and it gives the penetration. Vicat mould is in the form of a cylinder and it can be split into two halves. Vicat mould is placed on a non-porous plate. There are *three* attachments—square needle, plunger and needle with annular collar. Square needle is used for initial setting time test, plunger is used for consistency test and needle with annular collar is used for final setting time test.

(v) Plunger is attached to the movable rod of Vicat apparatus. The plunger is gently lowered on the paste in the mould.

(vi) The settlement of plunger is noted. If the penetration is between 5 mm to 7 mm from the bottom of mould, water added is correct. If penetration is not proper, process is repeated with different percentages of water till the desired penetration is obtained.

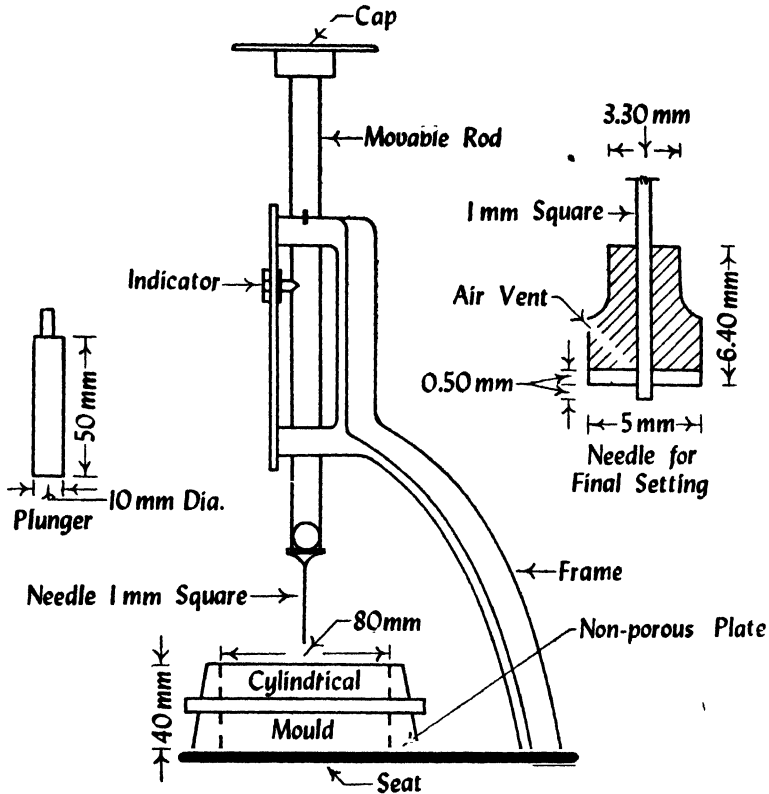

Vicat apparatus

FIG. 5-8

### (6) *Setting times:*

This test is used to detect the deterioration of cement due to storage. It may however be noted that this is purely a conventional type of test and it has no relation with the setting or hardening of actual concrete. Test is carried out to find out initial setting time and final setting time.

#### *Initial setting time:*

Following procedure is adopted:

(i) Cement weighing 300 gm is taken and it is mixed with percentage of water as determined in consistency test.

(ii) Cement paste is filled in Vicat mould.

(iii) Square needle of cross-section 1 mm  $\times$  1 mm is attached to the moving rod of Vicat apparatus.

(iv) The needle is quickly released and it is allowed to penetrate the cement paste. In the beginning, the needle penetrates completely. It is then taken out and dropped at a fresh place. The procedure is repeated at regular intervals till the needle does not penetrate completely. The needle should penetrate upto about 5 mm measured from bottom.

(v) Initial setting time is the interval between the addition of water to cement and the stage when needle ceases to penetrate completely. This time should be about 30 minutes for ordinary cement.

#### *Final setting time:*

Following procedure is adopted:

(i) Cement paste is prepared as above and it is filled in Vicat mould.

(ii) Needle with annular collar is attached to the moving rod of Vicat apparatus. This needle has a sharp point projecting in the centre with annular collar as shown in fig. 5-8.

(iii) The needle is gently released. The time at which the needle makes an impression on test block and the collar fails to do so is noted.

(iv) Final setting time is the difference between the time at which water was added to cement and time as recorded in (iii). This time should be about 10 hours for ordinary cement.

#### **(7) Soundness:**

The purpose of this test is to detect the presence of uncombined lime in cement. This test is performed with the help of Le Chatelier apparatus as shown in fig. 5-9. It consists of a brass mould of diameter 30 mm and height 30 mm. There is a split in mould and it does not exceed

0.50 mm. On either side of split, there are two indicators with pointed ends. Thickness of mould cylinder is 0.50 mm.

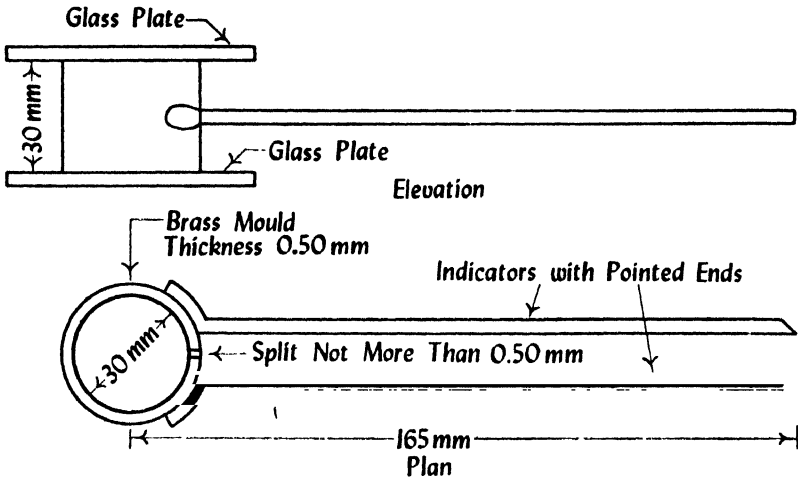

Le Chatelier apparatus

FIG. 5-9

Following procedure is adopted:

(i) Cement paste is prepared. Percentage of water is taken as determined in consistency test.

(ii) The mould is placed on a glass plate and it is filled by cement paste.

(iii) It is covered at top by another glass plate. A small weight is placed at top and the whole assembly is submerged in water for 24 hours. Temperature of water should be between 24°C to 35°C.

(iv) The distance between the points of indicator is noted. The mould is again placed in water and heat is applied in such a way that boiling point of water is reached in about 30 minutes. Boiling of water is continued for one hour.

(v) The mould is removed from water and it is allowed to cool down.

(vi) The distance between the points of indicator is again measured. The difference between the two readings indicates the expansion of cement and it should not exceed 10 mm.

**Storage of cement:**

Cement should be stored carefully. Otherwise it may absorb moisture from the atmosphere and may become useless for structural work. Following precautions are to be taken for storage of cement:

**(1) *Moisture:***

If moisture is kept away from cement, it is found that cement will maintain its quality for indefinite period. An absorption of one to two per cent of moisture has no appreciable effect on quality of cement. But if moisture absorption exceeds 5 per cent, cement becomes totally useless. Hence, when cement is to be stored for a long period, it should be stored in air-tight containers.

**(2) *Period of storage:***

Loose cement may be stored indefinitely in air-tight containers. But it is advisable to avoid storing of cement in jute bags for a period longer than 3 months. If it is unavoidable, cement should be tested to ascertain its properties.

**(3) *Piles:***

Cement bags are stacked in piles. It is economical to form a pile of 10 bags of cement. A distance of about 30 cm should be kept between the piles of cement bags and exterior walls of building. Passages of width about 90 cm should be provided between the piles. For long storage, top and bottom of piles should be covered with tarpaulins or waterproof paper.

**(4) *Quality of cement:***

Cement which is finely ground is more active and consequently, it absorbs moisture rapidly from the atmosphere. Hence extraordinary precautions should be taken to store finely ground cement.

**(5) *Removal of cement:***

When cement bags are to be removed from piles of sufficient height, steps should be formed by taking out two or

three bags from front piles. It is also advisable to remove cement in order of its storage period, i.e., cement which is stored previously should be taken out first. In other words, rule of *first in, first out* should be followed.

### (6) *Storage sheds:*

For storing cement for a sufficiently long period, storage sheds of special design should be constructed. Walls, roof and floor of such sheds should be of water-proof construction. Few small windows should be provided and they should be kept tightly shut. Floor should be above ground. If necessary, drainage should be provided to drain water collected in vicinity of such shed. For determining the size of storage shed, it is found that 20 bags or 1 tonne of cement will require about 1 m<sup>3</sup> of space.

### **Uses of cement:**

At present, cement is widely used in the construction of various engineering structures. It has proved to be one of the leading engineering material of modern times and has no rivals in production and applications. Following are various possible uses of cement:

- (1) Cement mortar for masonry work, plaster, pointing, etc.
- (2) Concrete for laying floors, roofs and constructing lintels, beams, weather sheds, stairs, pillars, etc.
- (3) Construction of important engineering structures such as bridges, culverts, dams, tunnels, storage reservoirs, light houses, docks, etc.
- (4) Construction of water tanks, wells, tennis courts, septic tanks, lamp posts, roads, telephone cabins, etc.
- (5) Making joints for drains, pipes, etc.
- (6) Manufacture of precast pipes, piles, garden seats, artistically designed urns, flower pots, etc., dust bins, fencing posts, etc.
- (7) Preparation of foundations, watertight floors, footpaths, etc.

### Varieties of cement:

In addition to ordinary cement, following are the other varieties of cement:

- (1) Acid-resistant cement
- (2) Blast furnace cement
- (3) Coloured cement
- (4) Expanding cement
- (5) High alumina cement
- (6) Hydrophobic cement
- (7) Low heat cement
- (8) Pozzuolana cement
- (9) Quick setting cement
- (10) Rapid hardening cement
- (11) Sulphate resisting cement
- (12) White cement.

Each variety of cement will now be discussed in brief.

#### (1) *Acid-resistant cement:*

An acid-resistant cement is composed of the following:

- (1) acid-resistant aggregates such as quartz, quartzites, etc.;
- (2) additive such as sodium fluosilicate  $\text{Na}_2 \text{SiF}_6$ ; and
- (3) aqueous solution of sodium silicate or soluble glass.

The addition of additive sodium fluosilicate accelerates the hardening process of soluble glass and it also increases the resistance of cement to acid and water.

The binding material of acid-resistant cement is soluble glass which is a water solution of sodium silicate,  $\text{Na}_2\text{O} \cdot n\text{SiO}_2$  or potassium silicate,  $\text{K}_2\text{O} \cdot n\text{SiO}_2$ , where  $n$  is the glass modulus. The term *glass modulus* is used to indicate the ratio of the number of silica molecules to that of alkali oxide molecules and its value in soluble glass varies from 2.50 to 3.50.

The acid-resistant cement is used for acid-resistant and heat-resistant coatings of installations of chemical industry.

It is not water-resistant and it fails when attacked by water or weak acids. By adding 0.50 per cent of linseed oil or 2 per cent of ceresit, its resistance to water is increased and it is then known as *acid and water resistant cement*.

### (2) *Blast furnace cement:*

For this cement, slag as obtained from blast furnace is used. Slag is a waste product in the manufacturing process of pig-iron and it contains the basic elements of cement, namely, alumina, lime and silica. Clinkers of cement are ground with about 60 to 65 per cent of slag.

The properties of this cement are more or less the same as those of ordinary cement. Its strength in early days is less and hence, it requires longer curing period. It proves to be economical as slag which is a waste product is used in its manufacture.

### (3) *Coloured cement:*

Cement of desired colour may be obtained by intimately mixing mineral pigments with ordinary cement. The amount of colouring material may vary from 5 to 10 per cent. If this percentage exceeds 10 per cent, the strength of cement is affected.

Chromium oxide gives green colour. Cobalt imparts blue colour. Iron oxide in different proportions gives brown, red or yellow colour. Manganese dioxide is used to produce black or brown coloured cement.

Coloured cements are widely used for finishing of floors, external surfaces, artificial marble, window sill slabs, textured panel faces, stair treads, etc.

### (4) *Expanding cement:*

This type of cement is produced by adding an expanding medium like sulpho-aluminate and a stabilising agent to ordinary cement. Hence this cement expands whereas other cements shrink.

Expanding cement is used for the construction of water retaining structures and also for repairing the damaged concrete surfaces.

**(5) High alumina cement:**

This cement is produced by grinding clinkers formed by calcining bauxite and lime. Bauxite is an aluminium ore. It is specified that total alumina content should not be less than 32 per cent and the ratio by weight of alumina to lime should be between 0.85 and 1.30. This cement is known by the trade names of 'Cement Fondu' in England and 'Lumnite' in America.

Following are the *advantages* of this cement:

- (i) Initial setting time of this cement is more than 3½ hours. Final setting time is about 5 hours. It, therefore, allows more time for mixing and placing operations.
- (ii) It can stand high temperatures.
- (iii) It evolves great heat during setting. It is, therefore, not affected by frost.
- (iv) It resists the action of acids in a better way.
- (v) It sets quickly and attains higher ultimate strength in a short period. Its strength after 1 day is about 400 kg/cm<sup>2</sup> and that after 3 days is about 500 kg/cm<sup>2</sup>.
- (vi) Its setting action mainly depends on the chemical reactions and hence, it is not necessary to grind it to fine powder.

Following are the *disadvantages* of this cement:

- (i) Extreme care is to be taken to see that it does not come in contact with even traces of lime or ordinary cement.
- (ii) It cannot be used in mass construction as it evolves great heat and as it sets soon.
- (iii) It is costly.

**(6) Hydrophobic cement:**

This type of cement contains admixtures which decrease the wetting ability of cement grains. The usual hydrophobic admixtures are acidol, naphthenes soap, oxidised petrolatum, etc. These substances form a thin film around cement grains. When water is added to hydrophobic cement, the absorption

films are torn off the surface and they do not in any way, prevent the normal hardening of cement. However, in initial stages, the gain in strength is less as hydrophobic films on cement grains prevent the interaction with water. However, its strength after 28 days is equal to that of ordinary portland cement.

When hydrophobic cement is used, the fine pores in concrete are uniformly distributed and thus the frost resistance and water resistance of such concrete are considerably increased.

### (7) *Low heat cement:*

Considerable heat is produced during the setting action of cement. In order to reduce the amount of heat, this type of cement is used. It contains lower percentage of tri-calcium aluminate  $C_3A$  and higher percentage of dicalcium silicate  $C_2S$ .

This cement possesses less compressive strength. Initial setting time is about one hour and final setting time is about 10 hours. It is mainly used for mass concrete work.

### (8) *Pozzuolana cement:*

Pozzuolana is a volcanic powder. It is found in Italy near Vesuvius. It resembles surkhi which is prepared by burning bricks made from ordinary soils. It can also be processed from shales and certain types of clays. The percentage of pozzuolana material should be between 10 to 30.

Following are the *advantages* of this cement:

- (i) It attains compressive strength with age.
- (ii) It can resist action of sulphates.
- (iii) It evolves less heat during setting.
- (iv) It imparts higher degree of watertightness.
- (v) It imparts plasticity and workability to mortar and concrete prepared from it.
- (vi) It is cheap.
- (vii) It offers great resistance to expansion.
- (viii) It possesses higher tensile strength.

Following are the *disadvantages* of this cement:

- (i) Its compressive strength in early days is less.
- (ii) It possesses less resistance to erosion and weathering action.

This cement is used to prepare mass concrete of lean mix and for marine structures. It is also used in sewage works and for laying concrete under water.

**(9) Quick setting cement:**

This cement is produced by adding a small percentage of aluminium sulphate and by finely grinding the cement. Percentage of gypsum or retarder for setting action is also greatly reduced. Addition of aluminium sulphate and fineness of grinding are responsible for accelerating the setting action of cement. The setting action of cement starts within five minutes after addition of water and it becomes hard like stone in less than 30 minutes or so.

Extreme care is to be taken when this cement is used as mixing and placing of concrete are to be completed in a very short period. This cement is used to lay concrete under static water or running water.

**(10) Rapid hardening cement:**

Initial and final setting times of this cement are the same as those of ordinary cement. But it attains high strength in early days. This is due to the following facts:

- (i) burning at high temperatures,
- (ii) increased lime content in cement composition, and
- (iii) very fine grinding.

This cement is slightly costlier than ordinary cement, but it offers the following *advantages*:

- (i) As it sets rapidly, construction work may be carried out speedily.
- (ii) Formwork of concrete can be removed earlier and it can therefore be used frequently.
- (iii) It obtains strength in a short period. Compressive strength at the end of one day is about  $115 \text{ kg/cm}^2$  and that at the end of 3 days is about  $210 \text{ kg/cm}^2$ .

Similarly, tensile strength at the end of one day is about 20 kg/cm<sup>2</sup> and that at the end of 3 days is about 30 kg/cm<sup>2</sup>.

- (iv) It is light in weight.
- (v) It is not damaged easily.
- (vi) Structural members constructed with this cement may be loaded earlier.
- (vii) This cement requires short period of curing.
- (viii) Use of this cement allows higher permissible stresses in the design. It therefore results in economic design.

**(11) *Sulphate resisting cement:***

In this cement, percentage of tricalcium aluminate is kept below 5 to 6 per cent and it results in the increase in resisting power against sulphates.

This cement is used for structures which are likely to be damaged by severe alkaline conditions such as canal linings, culverts, syphons, etc.

**(12) *White cement:***

This is just a variety of ordinary cement and it is prepared from such raw materials which are practically free from colouring oxides of iron, manganese or chromium. It is white in colour and it is used for floor finish, plaster work, ornamental work, etc. It should not set earlier than 30 minutes. It should be carefully transported and stored in closed containers only. It is more costly than ordinary cement because of specific requirements imposed upon the raw materials and the manufacturing process.

## QUESTIONS

1. Explain composition of ordinary cement.
2. Explain the functions of cement ingredients.

3. How does cement set? What are the functions of four principle minerals?
4. Differentiate between the following:
  - (1) Natural cement and artificial cement
  - (2) Cement and lime
  - (3) Dry process and wet process
  - (4) Initial setting time and final setting time
  - (5) White cement and ordinary cement
  - (6) Acid-resistant cement and hydrophobic cement
  - (7) Ball mill and tube mill
  - (8) Clinkers and nodules
  - (9) Quick setting cement and rapid hardening cement.
5. Describe the guiding factors which are to be paid attention to while making selection for site of a proposed cement factory.
6. Discuss at length the manufacturing process of ordinary cement.
7. Write short notes on:
  - (1) Fineness test
  - (2) Compressive strength test
  - (3) Tensile strength test
  - (4) Consistency test
  - (5) Soundness test
  - (6) Quick setting cement
  - (7) Acid-resistant cement
  - (8) Clinkers
  - (9) White cement
  - (10) Hydrophobic cement.
8. Explain the functions of ball mills and tube mills.
9. Describe the field tests for cement.
10. Enumerate the laboratory tests for cement and describe any two of them.
11. What are the precautions which are to be taken for the storage of cement?
12. Mention the uses of cement.
13. State the advantages and disadvantages of high alumina cement.

14. What is rapid hardening cement? What are its advantages?
15. Enumerate the various varieties of cement in addition to ordinary cement.
16. Give sketches of the following:
  - (1) Rotary kiln
  - (2) Le Chatelier apparatus
  - (3) Standard briquette
  - (4) Vicat apparatus
  - (5) Vertical section of a ball mill
  - (6) Longitudinal section of a tube mill.
17. What are the advantages and disadvantages of pozzuolana cement?
18. Draw the flow diagrams for mixing of raw materials by dry process and wet process for the manufacture of ordinary cement.
19. What are the harmful constituents of cement?
20. Draw the flow diagram of burning and grinding operations involved in the manufacture of ordinary cement.
21. Give reasons for the following:
  - (1) Dry process has been practically replaced at present by wet process of mixing of raw materials.
  - (2) During grinding of cement, a small quantity of gypsum is added.
  - (3) Cement should be stored carefully.
  - (4) It is not necessary to grind high alumina cement to fine powder.
  - (5) The proportion of lime in cement is to be carefully maintained.
  - (6) Quick setting cement is used to lay concrete under static water or running water.
  - (7) White cement is more costly than ordinary cement.
  - (8) Cement with a high content of  $C_2S$  is used for hydraulic engineering constructions.

# Chapter 6

## MORTAR

### **Definition:**

The term mortar is used to indicate a paste prepared by adding required quantity of water to a mixture of binding material like cement or lime and fine aggregate like sand. The above two components of mortar, namely, the binding material and fine aggregate are sometimes referred to as matrix and adulterant respectively. The matrix binds the particles of the adulterant and as such, the durability, quality and strength of mortar will mainly depend on the quantity and quality of the matrix.

### **Sand:**

We have studied cement and lime in previous chapters. Sand forms an important ingredient of mortar. Its different aspects will now, therefore, be briefly discussed.

### **Natural sources of sand:**

Sand particles consist of small grains of silica ( $\text{SiO}_2$ ). It is formed by the decomposition of sandstones due to various effects of weather. According to the natural sources from which sand is obtained, it is of the following *three* types:

- (1) Pit sand
- (2) River sand
- (3) Sea sand.

#### **(1) *Pit sand:***

This sand is obtained by forming pits into soils and the pit sand is obtained from a depth of about 1 m to 2 m from ground level. Pit sand consists of sharp angular grains which are free from salts. For making mortar, clean pit sand should only be used.

#### **(2) *River sand:***

This sand is obtained from banks or beds of rivers. River sand consists of fine rounded grains. Colour of river sand is almost white. As river sand is usually available in clean condition, it is widely used for all purposes.

### (3) *Sea sand:*

This sand is obtained from sea shores. Sea sand, like river sand, consists of fine rounded grains. Colour of sea sand is light brown. Sea sand contains salts. These salts attract moisture from the atmosphere. Such absorption causes dampness, efflorescence and disintegration of work. Sea sand also retards the setting action of cement. Due to all such reasons, it is the general rule to avoid the use of sea sand for engineering purposes.

### **Classification of sand:**

According to the size of grains, sand is classified as fine, coarse and gravelly.

Sand passing through a screen with clear openings of 1.5875 mm is known as *fine sand*. It is mainly used for plastering.

Sand passing through a screen with clear openings of 3.175 mm is known as *coarse sand*. It is generally used for masonry work.

Sand passing through a screen with clear openings of 7.62 mm is known as *gravelly sand*. It is usually used for concrete work.

### **Bulking of sand:**

The Presence of moisture in sand increases the volume of sand. This is due to the fact that moisture causes films of water around sand particles which results in the increase of volume of sand. For a moisture content of about 5 to 8 per cent, this increase of volume may be as much as 20 to 40 per cent, depending upon the grading of sand. The finer the material, the more will be the increase in volume for a given moisture content. This phenomena is known as *bulking of sand*.

When moisture content is increased by adding more water, sand particles pack near each other and the amount of bulking of sand is decreased. Thus the dry sand and the sand completely flooded with water have practically the same volume.

A very simple test, as shown in fig. 6-1, may be carried out to decide the percentage of bulking of sand. Following procedure is adopted:

- (i) A container is taken and it is filled two-third with the sample of sand to be tested.
- (ii) The height is measured, say it is 20 cm.
- (iii) Sand is taken out of container. Care should be taken to see that there is no loss of sand during this transaction.
- (iv) The container is filled with water.
- (v) Sand is then slowly dropped in the container and it is thoroughly stirred by means of a rod.
- (vi) The height of sand is measured, say it is 16 cm.

Then,

$$\text{Bulking of sand} = \frac{20 - 16}{16} = \frac{4}{16} = \frac{1}{4} \text{ or } 25\%.$$

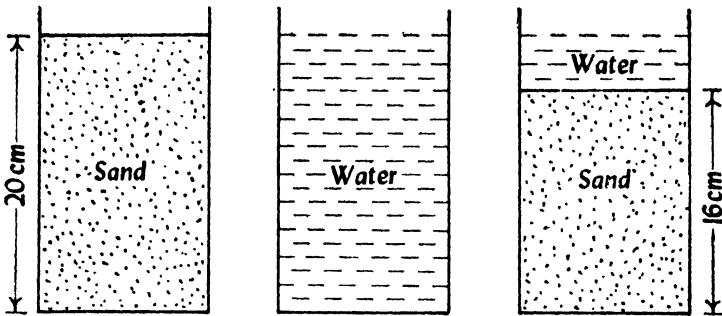

Bulking of sand

FIG. 6-1

### Properties of good sand:

Following are the properties of good sand:

- (i) It should be chemically inert.
- (ii) It should be clean and coarse. It should be free from any organic or vegetable matter.
- (iii) It should contain sharp, angular and durable grains.
- (iv) It should not contain salts which attract moisture from the atmosphere.

### Function of sand in mortar:

Sand is used in mortar for the following purposes:

**(1) Bulk:**

It does not increase the strength of mortar. But it acts as adulterant. Hence, bulk or volume of mortar is increased which results in reduction of cost.

**(2) Setting:**

If building material is fat lime, carbon dioxide is absorbed through the voids of sand and setting of fat lime occurs effectively.

**(3) Shrinkage:**

It prevents excessive shrinkage and hence, cracking of mortar during setting is avoided.

**(4) Strength:**

It helps in the adjustment of strength of mortar or concrete by variation of its proportion with cement or lime. It also increases the resistance of mortar against crushing.

**Tests for sand:**

Following tests may be carried out to ascertain the properties of sand:

(i) A glass of water is taken and some quantity of sand is placed in it. It is then vigorously shaken and allowed to settle. If clay is present in sand, its distinct layer is formed at top of sand.

(ii) For detecting the presence of organic impurities in sand, solution of sodium hydroxide or caustic soda is added to sand and it is stirred. If colour of solution changes to brown, it indicates the presence of organic matter.

(iii) Sand is actually tasted and from its taste, presence of salts is known.

(iv) Sand is taken from a heap and it is rubbed against the fingers. If fingers are stained, it indicates that sand contains earthy matter.

**Substitutes for sand:**

In place of sand, other materials such as stone screenings, burnt clay or surkhi, cinders or ashes from coal, coke dust,

etc. may be used to prepare mortar. Stone screenings are obtained by screening crushed stones. They are sharp and impart more strength to mortar.

Surkhi is the popular substitute for sand. It is obtained by finely grinding burnt clay. It should be clean and free from any impurities. It plays the same functions as those of sand. But in addition, it gives strength and improves hydraulic property of the mortar. As it disintegrates under the action of air and humidity, mortar with surkhi should not be used for external plaster or pointing work.

### **Classification of mortars:**

Mortars are classified on the basis of the following:

- (1) Bulk density
- (2) Kind of binding material
- (3) Nature of application
- (4) Special mortars.

#### **(1) Bulk density:**

According to the bulk density of mortar in dry state, there are *two* types of mortars:

- (i) Heavy mortars
- (ii) Light-weight mortars.

##### **(i) Heavy mortars:**

Mortars having bulk density of  $1500 \text{ kg/m}^3$  or more are known as heavy mortars and they are prepared from heavy quartzs or other sands.

##### **(ii) Light-weight mortars:**

Mortars having bulk density less than  $1500 \text{ kg/m}^3$  are known as light-weight mortars and they are prepared from light porous sands from pumice and other fine aggregates.

#### **(2) Kind of binding material:**

The kind of binding material for a mortar is selected by keeping in mind several factors such as expected working conditions, hardening temperature, moisture conditions, etc.

According to the kind of binding material, the mortars are classified into the following *four* categories:

- (i) Lime mortar
- (ii) Cement mortar
- (iii) Gauged mortar
- (iv) Gypsum mortar.

(i) *Lime mortar:*

In this type of mortar, lime is used as binding material. Lime may be fat lime or hydraulic lime.

Fat lime shrinks to a great extent and hence, it requires about 2 to 3 times its volume of sand. Lime should be slaked before use. This mortar is unsuitable for water-logged areas or in damp situations.

For hydraulic lime, proportion of lime to sand by volume is about 1:2 or so. This mortar should be consumed within one hour after mixing. It possesses more strength and can be used in damp situations.

Lime mortar has a high plasticity and it can be placed easily. It possesses good cohesiveness with other surfaces and shrinks very little. It is sufficiently durable, but it hardens slowly. It is generally used for lightly loaded above-ground parts of buildings.

(ii) *Cement mortar:*

In this type of mortar, cement is used as binding material. Depending upon the strength required and importance of the work, proportion of cement to sand by volume varies from 1:2 to 1:6 or more. It should be noted that surkhi and cinder are not chemically inert substances and hence they cannot be used as adulterants with matrix as cement. Thus sand only can be used to form cement mortar. The proportion of cement with respect to sand should be determined with due regard to the specified durability and working conditions. Cement mortar is used where a mortar of high strength and water-resisting properties is required such as underground constructions, water saturated soils, etc.

(iii) *Gauged mortar:*

To improve the quality of lime mortar, cement is sometimes added to it. This process is known as gauging. It makes lime mortar economical, strong and dense. Usual proportion of cement to lime by volume is about 1:6 to 1:8. It is also known as a composite mortar and it can also be formed by the combination of cement and clay.

(iv) *Gypsum mortar:*

These mortars are prepared from gypsum binding materials such as building gypsum and anhydrite binding materials.

**(3) Nature of application:**

According to the nature of application, the mortars are classified into *two* categories:

- (i) Bricklaying mortars
- (ii) Finishing mortars.

(i) *Bricklaying mortars:*

Mortars for bricklaying are intended to be used for brickwork and walls. Depending upon the working conditions and type of construction, the composition of masonry mortars with respect to the kind of binding material is decided.

(ii) *Finishing mortars:*

These mortars include common plastering work and mortars for developing architectural or ornamental effects. Cement or lime is generally used as a binding material for ordinary plastering mortar. For decorative finishing, the mortars are composed of suitable materials with due consideration of mobility, water retention, resistance to atmospheric actions, etc.

**(4) Special mortars:**

Following are the various types of special mortars which are used for certain conditions:

- (i) Fire-resistant mortar
- (ii) Light-weight mortar
- (iii) Packing mortar
- (iv) Sound-absorbing mortar
- (v) X-ray shielding mortar.

(i) *Fire-resistant mortar:*

This mortar is prepared by adding aluminous cement to finely crushed powder of fire-bricks. Usual proportion is 1 part of aluminous cement to 2 parts of powder of fire-bricks.

This mortar is fire-resistant and it is, therefore, used with fire-bricks for lining furnaces, fire places, ovens, etc.

(ii) *Light-weight mortar:*

This mortar is prepared by adding materials such as saw dust, wood powder, etc. to lime mortar or cement mortar. Other materials which may be added are asbestos fibres, jute fibres, etc. This mortar is used in sound-proof and heat-proof constructions.

(iii) *Packing mortar:*

To pack oil wells, special mortars possessing the properties of high homogeneity, water resistance, predetermined setting time, ability to form solid waterproof plugs in cracks and voids of rocks, resistance to subsoil water pressure, etc. have to be formed. The varieties of packing mortars include cement-sand, cement-loam and cement-sand-loam. The composition of packing mortar is decided by taking into consideration the hydrogeologic conditions, packing methods and type of timbering.

(iv) *Sound-absorbing mortar:*

To reduce the noise level, sound-absorbing plaster is formed with the help of sound-absorbing mortar. Bulk density of such a mortar varies from 600 to 1200 kg/m<sup>3</sup> and the binding materials employed in its composition may be portland cement, lime, gypsum, slag portland cement, etc. The aggregates are selected from light-weight porous materials such as pumice, cinders, etc.

(v) *X-ray shielding mortar:*

This type of mortar is used for providing the plastering coat to walls and ceilings of X-ray cabinets. It is a heavy type of mortar with bulk density over 2200 kg/m<sup>3</sup>. The aggregates are obtained from heavy rock and suitable

admixtures are added to enhance the protective property of such a mortar.

### **Properties of good mortar:**

Following are the properties of a good mortar:

- (1) It should be capable of developing good adhesion with the building units such as bricks, stones, etc.
- (2) It should be capable of developing the designed stresses.
- (3) It should be capable of resisting penetration of rain water.
- (4) It should be cheap.
- (5) It should be durable.
- (6) It should be easily workable.
- (7) It should not affect the durability of materials with which it comes into contact.
- (8) It should set quickly so that speed in construction may be achieved.
- (9) The joints formed by mortar should not develop cracks and they should be able to maintain their appearance for a sufficiently long period.

### **Preparation of mortar:**

For preparing mortar, water is added to an intimate mixture of binding material and sand. Water to be used for this purpose should be free from clay, earth and other impurities. Water which is fit for drinking should only be used for preparing mortar. Different mortars are prepared in the following ways:

#### **(1) *Lime mortar:***

Lime mortar is prepared either by pounding or grinding. Pounding is adopted for preparing small quantities of mortar. Grinding is adopted for preparing large quantities of mortar and to ensure a steady and continuous supply of mortar.

**Pounding :**

In this method, pits are formed in hard ground and they are provided with lining of bricks or stones at their sides and bottom. Pits are about 180 cm long, 40 cm wide at bottom, 50 cm wide at top and 50 cm deep. Lime and sand are mixed in dry state and the mixture is then placed in pits. A small quantity of water is added and four to five persons with heavy wooden pounders or beaters work on mortar. They turn mortar up and down frequently. Required quantity of water is added at intervals. When desired consistency is achieved, mortar from pits is taken out. This method of preparing lime mortar is not efficient.

**Grinding :**

In this method, grinding mills are used to prepare mortar. These mills are of the following *two* types:

- (i) Bullock-driven grinding mills
  - (ii) Power-driven grinding mills.
- (i) Bullock-driven grinding mills:

This is also known as *ghani*. Fig. 6-2 shows the details of a typical bullock-driven grinding mill. A circular trench

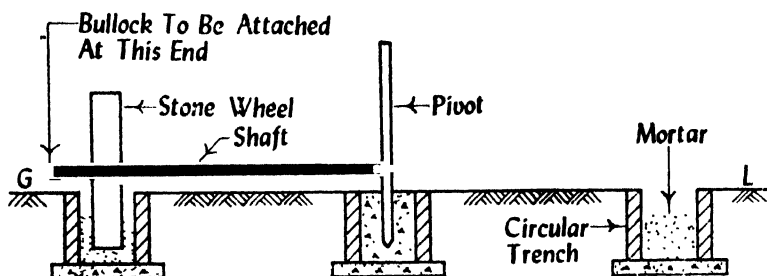

Bullock-driven grinding mill

FIG. 6-2

of diameter about 6 m to 9 m and depth of about 40 cm is prepared. Width of the trench is about 30 cm or so to accommodate stone wheel with side margins of about 50 mm. A horizontal wooden shaft passes through stone wheel. One end of shaft is attached to pivot and at the other end, bullock is attached to cause rotation of stone wheel.

Lime and sand in required proportions are placed in the trench. Required quantity of water is added and bullock is allowed to take turns round the mill. As bullock rotates, lime and sand are intimately mixed by the grinding action of stone wheel. In addition, they are also frequently turned with the help of spade. To record the number of turns made by the bullock, an arrangement known as beale's tell-tale is provided at the pivot. It is in the form of a spindle with groove. A turn is indicated by the rise or fall of groove.

A normal ghani can prepare about  $1.70 \text{ m}^3$  of mortar at a time and it will require a period of about 6 hours to complete one cycle of operations.

(ii) Power-driven grinding mills:

In this type of mill, power is used to mix intimately lime and sand. Fig. 6-3 shows a typical power-driven grinding mill. It consists of a revolving pan of diameter about 180 cm to 240 cm. In this pan, two rollers are provided. Rollers are fixed. Pan is revolved either with the help of an oil engine or steam engine or electric power.

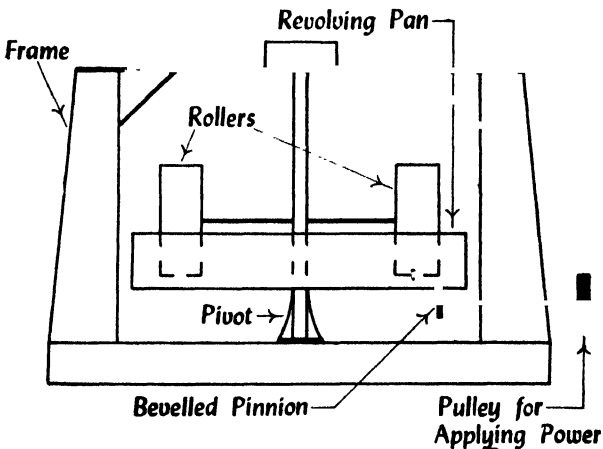

Power-driven grinding mill

FIG. 6-3

Lime and sand in required proportions are placed in pan. Required quantity of water is added and pan is then

revolved. This method of grinding lime mortar is quite efficient and it produces mortar of better quality. It also ensures steady and continuous supply of mortar.

**(2) *Cement mortar:***

This mortar does not require pounding or grinding. Cement and sand are mixed in required proportions in dry state on a watertight platform or steel trough. Mixing in dry state is done twice or thrice. Water is then added and ingredients are again thoroughly mixed.

**(3) *Gauged mortar:***

Lime mortar is prepared as shown above. Required quantity of cement is then added and ingredients are thoroughly turned up and down to cause intimate mixing.

**Uses of mortar:**

Following are the uses of mortar:

- (1) to bind the building units such as bricks, stones, etc.,
- (2) to carry out pointing and plaster work on exposed surfaces of masonry,
- (3) to form an even bedding layer for building units,
- (4) to form joints of pipes,
- (5) to improve the appearance of structure,
- (6) to prepare moulds,
- (7) to serve as a matrix or cavity to hold coarse aggregates, etc.

**Precautions in using mortar:**

Following precautions are to be taken while making use of mortar:

**(1) *Consumption of mortar:***

After preparation, mortar should be consumed as early as possible. Lime mortar should be consumed within 36

hours after its preparation and it should be kept wet or damp. Cement mortar should be consumed within 30 minutes after its preparation and for this reason, it is advisable to prepare cement mortar of one bag of cement at a time.

(2) ***Frost action:***

Setting action of mortar is affected by the presence of frost. It is, therefore, advisable to stop the work in frosty weather or to execute it with cement mortar which will set before it tries to freeze.

(3) ***Soaking of building units:***

The presence of water in mortar is essential to cause its setting action. Hence, building units should be soaked in water before mortar is applied. If this precaution is not taken, water of mortar will be absorbed by the building units and the mortar will become weak.

(4) ***Sprinkling of water:***

The construction work carried out by mortar should be kept damp or wet by sprinkling water to avoid rapid drying of mortar. Water may be sprinkled for about 7 to 10 days. Exposed surfaces are sometimes covered to give protection against sun and wind.

(5) ***Workability:***

Mortar should not contain excess water and it should be as stiff as can be conveniently used. Joints should be well formed and excess mortar from joints should be neatly taken off by a trowel. Surfaces formed by mortar for building units to rest should be even.

**Selection of mortar:**

Depending upon the nature of work, type of mortar should be selected. Table 6-1 shows the types of mortars to be used for various engineering constructions.

**TABLE 6-1**  
**SELECTION OF MORTARS**

Sr.No.	Nature of work	Type of mortar
1.	Construction work in water-logged areas and exposed positions	Cement or lime mortar prop. 1:3, lime being eminently hydraulic lime.
2.	Damp proof courses and cement concrete roads	Cement mortar prop. 1:2.
3.	General R.C.C. work such as lintels, pillars, slabs, stairs, etc.	Cement mortar prop. 1:2, the concrete mix being 1:2:4.
4.	Internal walls and surfaces of less importance	Lime cinder mortar prop. being 1:3. Sand is replaced by ashes or cinder.
5.	Mortar for laying fire-bricks	Fire-resisting mortar consisting of 1 part of aluminous cement to 2 parts of finely crushed powder of fire-bricks.
6.	Partition walls and parapet walls	Cement mortar prop. 1:3 or lime mortar prop. 1:1. Lime should be moderately hydraulic lime.
7.	Plaster work	Cement mortar prop. 1:3 to 1:4 or lime mortar prop. 1:2.
8.	Pointing work	Cement mortar prop. 1:1 to 1:2.
9.	Reinforced brickwork	Cement mortar prop. 1:3.
10.	Stone masonry with best varieties of stones	Lime mortar prop. 1:2, lime being eminently hydraulic lime.
11.	Stone masonry with ordinary stones, brickwork, foundations, etc.	Lime mortar prop. 1:2 or cement mortar prop. 1:6. Lime should be eminently hydraulic lime or moderately hydraulic lime.
12.	Thin joints in brickwork	Lime mortar prop. 1:3, lime being fat lime.

### **Tests for mortars:**

Following are the usual tests for mortar:

- (1) Adhesiveness to building units
- (2) Crushing strength
- (3) Tensile strength.

#### **(1) Adhesiveness to building units:**

Following procedure is adopted to carry out this test:

(i) Two bricks are placed at right angles to each other as shown in fig. 6-4.

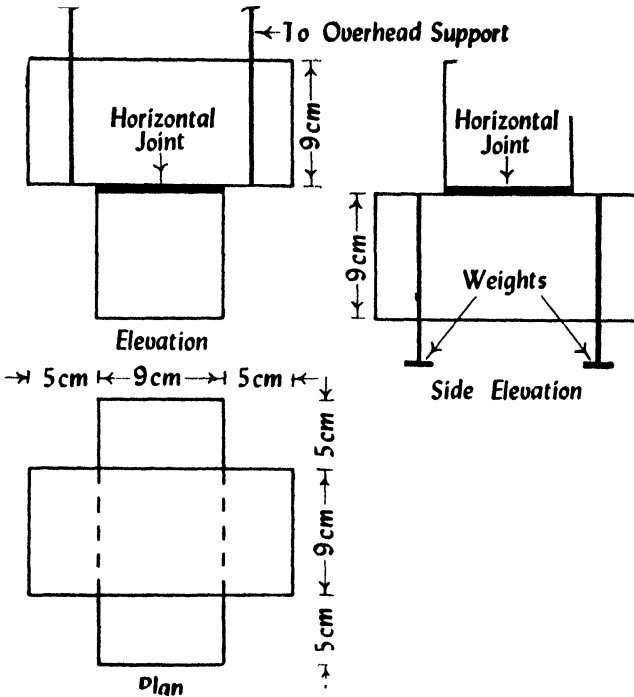

Test for adhesiveness

FIG. 6-4

(ii) Mortar is placed to join them so as to form a horizontal joint. If size of bricks is  $19\text{ cm} \times 9\text{ cm} \times 9\text{ cm}$ , a horizontal joint of  $9\text{ cm} \times 9\text{ cm} = 81\text{ cm}^2$  will be formed.

(iii) The upper brick is suspended from an overhead support and weights are attached to lower brick.

(iv) Weights are gradually increased till separation of bricks occurs.

(v) Ultimate adhesive strength of mortar per  $\text{cm}^2$  area is obtained by dividing maximum load with 81.

## (2) *Crushing strength:*

For this test, brickwork is carried out with mortar to be tested. A sample of this brickwork is taken and it is gradually loaded till failure occurs due to crushing. Ultimate crushing strength is obtained by dividing maximum load with cross-sectional area.

**(3) Tensile strength:**

For this test, mortar to be tested is placed in briquette moulds as shown in fig. 6-5. The briquettes are then tested

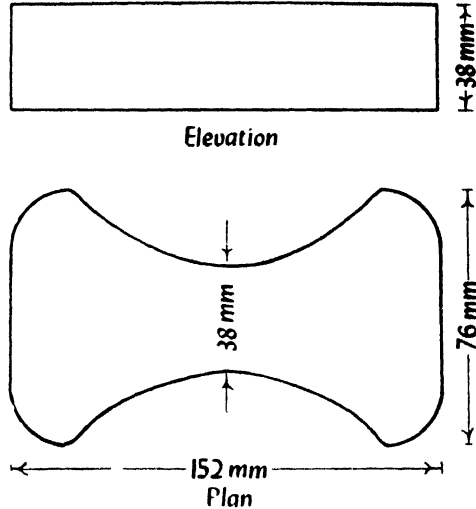

Briquette for tensile strength of mortar

FIG. 6-5

in a tension testing machine. Cross-sectional area of central portion is  $38 \text{ mm} \times 38 \text{ mm}$  or  $1444 \text{ mm}^2$  or  $14.44 \text{ cm}^2$ . Ultimate tensile stress per  $\text{cm}^2$  is obtained by dividing failing load with 14.44.

### QUESTIONS

1. What are natural sources of sand?
2. What is meant by bulking of sand? Explain it.
3. Distinguish between the following:
  - (1) Fine sand and coarse sand
  - (2) Lime mortar and gauged mortar
  - (3) River sand and sea sand
  - (4) Bullock-driven and power-driven grinding mills
  - (5) Pounding and power-driven grinding mills
  - (6) Matrix and adulterant
  - (7) Heavy mortars and light-weight mortars.

4. Mention the properties of good sand.
5. State the functions of sand in mortar.
6. Write short notes on:
  - (1) Classification of sand
  - (2) Substitutes for sand
  - (3) Preparation of cement mortar and gauged mortar
  - (4) Fire-resistant mortar
  - (5) Light-weight mortar
  - (6) Packing mortar
  - (7) Sound-absorbing mortar
  - (8) X-ray shielding mortar.
7. What are the tests carried out for sand?
8. Define mortar and discuss its varieties on the basis of nature of application.
9. How are mortars classified on the basis of bulk density and kind of binding material?
10. Discuss some of the special mortars.
11. Suggest the type of mortar for following works:
  - (1) Damp proof courses
  - (2) General R.C.C. work
  - (3) Internal walls
  - (4) Laying of fire-bricks
  - (5) Partition walls
  - (6) Plaster work
  - (7) Masonry work
  - (8) Pointing work
  - (9) Reinforced brickwork
  - (10) Cement concrete roads
  - (11) Fire-bricks
  - (12) Thin joints in brickwork.
12. State the properties of good mortar.
13. How is lime mortar prepared?
- 14. What are the uses of mortar?

15. Describe the usual tests for mortar.
16. What are the precautions to be taken while making the use of mortar?
17. Give sketches of the following:
  - (1) Bullock-driven grinding mill
  - (2) Power-driven grinding mill
  - (3) Briquette for tensile strength of mortar.
18. Give reasons for the following:
  - (1) River sand is widely used for all purposes.
  - (2) It is the general rule to avoid the use of sea sand for engineering purposes.
  - (3) Mortar with surkhi should not be used for external plaster or pointing work.
  - (4) It is advisable to prepare cement mortar of one bag of cement at a time.
  - (5) Building units should be soaked in water before mortar is applied.
  - (6) The dry sand and the sand completely flooded with water have practically the same volume.
  - (7) Due to presence of sand, cracking of mortar during setting is avoided.
  - (8) Mortar of fat lime and sand requires about 1 part of lime to 2 to 3 parts of sand by volume.
  - (9) Beale's tell-tale is provided at the pivot of bullock-driven grinding mill.
  - (10) It is advisable to stop the work with mortar in frosty weather.
  - (11) The construction work carried out by mortar should be kept damp or wet.
  - (12) Cement is sometimes added to lime mortar.
  - (13) Surkhi and cinder cannot be used as adulterants with matrix as cement.

# Chapter 7

## CEMENT CONCRETE

### Definition:

Cement concrete is a mixture of cement, sand, pebbles or crushed rock and water, which, when placed in the skeleton of forms and allowed to cure, becomes hard like a stone. Cement concrete has attained the status of a major building material in all branches of modern construction because of the following reasons:

- (1) It can be readily moulded into durable structural items of various sizes and shapes at practically no considerable labour expenditure.
- (2) It is possible to control the properties of cement concrete within a wide range by using appropriate ingredients and by applying special processing techniques—mechanical, chemical and physical.
- (3) It is possible to mechanise completely its preparation and placing processes.
- (4) It possesses adequate plasticity for mechanical working.

### Properties of cement concrete:

Cement concrete possesses the following important properties:

- (1) It has a high compressive strength.
- (2) It is free from corrosion and there is no appreciable effect of atmospheric agents on it.
- (3) It hardens with age and the process of hardening continues for a long time after the concrete has attained sufficient strength. It is this property of cement concrete which gives it a distinct place among the building materials.
- (4) It is proved to be more economical than steel. This is due to the fact that sand and pebbles or crushed rock, forming the bulk of cement concrete, to the extent of about 80 to 90%, are usually

available at moderate cost. Formwork, which is of steel or timber, can be used over and over again or for other purposes after it is removed.

- (5) It binds rapidly with steel and as it is weak in tension, steel reinforcement is placed in cement concrete at suitable places to take up the tensile stresses. This is termed as '*Reinforced Cement Concrete*' or simply '*R.C.C.*'
- (6) Under the following *two* conditions, it has a tendency to shrink:
  - (i) There is initial shrinkage of cement concrete which is mainly due to loss of water through forms, absorption by surfaces of forms, etc.
  - (ii) The shrinkage of cement concrete occurs as it hardens. This tendency of cement concrete can be minimised by proper curing of concrete.
- (7) It has a tendency to be porous. This is due to the presence of voids which are formed during and after its placing. *Two* precautions are necessary to avoid this tendency:
  - (i) There should be proper grading and consolidating of the aggregates.
  - (ii) Minimum water cement ratio should be adopted.
- (8) It forms a hard surface, capable of resisting abrasion.
- (9) It should be remembered that apart from other materials, concrete comes to the site in the form of raw materials only. Its final strength and quality depend entirely on local conditions and persons handling it. However, the materials of which concrete is composed may be subjected to rigid specifications.

### **Materials used in R.C.C. work:**

Following materials are required for making R.C.C.:

- (1) Cement
- (2) Aggregates
- (3) Steel
- (4) Water.

**(1) Cement:**

Before the introduction of ordinary portland cement, lime was used as a cementing material. Most of the cement concrete work in building construction is done with ordinary portland cement at present. But other special varieties of cement such as rapid hardening cement and high alumina cement are used under certain circumstances. The cement should comply with all the standard requirements.

**(2) Aggregates:**

These are the inert or chemically inactive materials which form the bulk of cement concrete. These aggregates are bound together by means of cement. The aggregates are classified into *two* categories: *fine and coarse*.

The material which is passed through 4.7625 mm size B.S. test sieve is termed as a fine aggregate. Usually natural river sand is used as a fine aggregate. But at places, where natural sand is not available economically, finely crushed stone may be used as a fine aggregate.

The material which is retained on 4.7625 mm size B.S. test sieve is termed as a coarse aggregate. Broken stone is generally used as a coarse aggregate. The nature of work decides the maximum size of the coarse aggregate. For thin slabs and walls, the maximum size of coarse aggregate should be limited to one-third the thickness of the concrete section.

The aggregates to be used for cement concrete work should be hard, durable and clean. The aggregates should be completely free from lumps of clay, organic and vegetable matter, fine dust, etc. The presence of all such debris prevents adhesion of aggregates and hence, reduces the strength of concrete.

**(3) Steel:**

The steel reinforcement is generally in the form of round bars of mild steel. The diameters of bars vary from 5 mm to 40 mm. Sometimes, square bars or twisted bars or ribbed-steel are used as steel reinforcement. For road slabs and such other constructions, reinforcement may also consist of sheets of rolled steel of suitable thickness. Hyrib which is a steel lath may also be used as steel reinforcement.

**(4) Water:**

This is the least expensive but most important ingredient of concrete. Water, which is used for making concrete, should be clean and free from harmful impurities such as oil, alkali, acid, etc. In general, water which is fit for drinking should be used for making concrete.

It may be noted that sometimes ingredients other than above are added in concrete to give it certain improved qualities. These ingredients or substances are known as *admixtures*. The addition of an admixture may improve the concrete with respect to its strength, hardness, workability, water-resisting power, etc. Following are the commonly used admixtures:

Alum, aluminium sulphate, barium oxide, bitumen, calcium chloride, coal ash, common salt, iron oxide, lime, mineral oils, organic oils, potassium chloride, silicate of soda, tar products, volcanic ashes, zinc chromate, etc.

**Corrosion of steel in concrete:**

Corrosion sometimes occurs to reinforcing bars placed in concrete. This is of course not a serious problem for majority of reinforced structures. The term *corrosion* is used to indicate the conversion of metals by natural agencies into various compounds. The term *rusting* is used to refer corrosion of ferrous metals.

**Theories of corrosion:**

Various theories of corrosion of steel in concrete have been developed. Following are *two* important theories of corrosion:

- (1) Chemical action theory
- (2) Electrolytic theory.

**(1) Chemical action theory:**

Following chemical reactions are involved in corrosion:

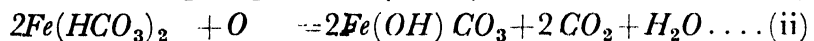

The combined action of oxygen, carbon dioxide and moisture on steel results in soluble ferrous bicarbonate

$Fe(HCO_3)_2$  as shown by reaction (i). This ferrous bicarbonate is then oxidised to basic ferric carbonate  $2Fe(OH)CO_3$  as shown by reaction (ii). This basic ferric carbonate is converted into hydrated ferric oxide  $Fe(OH)_3$  and carbon dioxide is liberated as shown by reaction (iii).

(2) *Electrolytic theory:*

According to this theory, metal contains anodic and cathodic areas and these areas, when connected by electrolytes such as water, moisture, aqueous solutions, etc. cause corrosion. These areas are developed in metal due to various reasons such as differences in metal composition, unequal concentration of oxygen on different parts of metal surface, etc.

***Causes of corrosion:***

Following are the factors responsible for causing corrosion of steel in concrete:

- (1) improper construction methods,
- (2) inadequate design procedure,
- (3) insufficient cover to steel from exposed concrete surface,
- (4) permeability of concrete which depends on various factors such as water-cement ratio, size of aggregate, curing, grading of aggregates, etc.,
- (5) poor workmanship,
- (6) presence of moisture in concrete,
- (7) presence of salts,
- (8) type of atmospheric conditions surrounding the region of concrete,
- (9) unequal distribution of oxygen over the steel surface, etc.

***Effect of corrosion:***

The action of corrosion of steel in concrete is very slow and except under exceptional circumstances, such corrosion does not decrease the life of concrete member. It should, however, be remembered that action of corrosion becomes more intensive when it is combined with adverse effects of internal and external stresses. One important effect of corrosion is the formation of cracks and these cracks usually

progress or advance most rapidly where shearing stresses are the greatest and where slipping occurs due to loss of bond.

### ***Prevention of corrosion:***

To minimise the chances of development of corrosion of steel in concrete, following preventive measures may be taken:

- (1) avoiding the steel to come into contact with bricks, soil, wood and other porous non-alkaline materials,
- (2) avoiding the use of materials which accelerate the process of corrosion, i.e., aggregates with high salt contents, water containing salts, etc.,
- (3) maintaining a high degree of workmanship,
- (4) proper structural design with due provision of cover,
- (5) providing cathodic protection to reinforcement by some suitable method,
- (6) providing surface coatings with paints, tars, asphalts, etc.
- (7) use of high quality and impermeable concrete, etc.

### **Sea water for making concrete:**

It is advisable, as stated above, to use clean water fit for drinking purposes for making cement concrete. However, at places where sea water is available in abundance and potable water is costly, sea water can be used for making cement concrete. The problem of using sea water for making cement concrete has to be studied from the following *two* aspects:

- (1) Strength
- (2) Corrosion of reinforcement.

#### ***(1) Strength:***

Table 7-1 shows the analysis of average sea water. It contains about 3.50 per cent of dissolved salts. The approximate percentages of various salts are 78 per cent of sodium chloride, 15 per cent of magnesium chloride and magnesium sulphate and the rest 7 per cent of calcium sulphate, potassium sulphate, etc. Now, all chlorides tend to accelerate the setting of cement and to improve the strength

of concrete in early stages. On the other hand, sulphates tend to retard the setting of cement and to discourage the strength of concrete in early stages. It is found that the net effect of these two contradictory actions is the fall in strength of concrete to the tune of about 8 to 20 per cent. Hence sea water can be used for making cement concrete for structures where such fall in strength is permissible or where it is possible to correct the same by adjusting water-cement ratio, cement content in concrete, etc.

**TABLE 7-1**  
COMPOSITION OF AVERAGE SEA WATER

Sr.No.	Constituent	Content in gm per litre
1.	Calcium (Ca)	0.43
2.	Chloride (Cl)	19.80
3.	Magnesium (Mg)	1.33
4.	Potassium (K)	0.40
5.	Sodium (Na)	11.00
6.	Sulphate (SO)	2.76
Total		35.72

Sea water tends to develop dampness and efflorescence. Hence it can be adopted for concrete structures where finishing characteristics are not important or where persistent dampness of surface is permissible.

### (2) *Corrosion of reinforcement:*

It is found that sea water does not lead to corrosion of reinforcement, provided concrete is dense and there is enough cover to the reinforcement. The minimum cement content for concrete permanently under sea water should be 300 kg per m<sup>3</sup> and the minimum cover over the reinforcement should be 75 mm. However, it is not advisable to take the risk of corrosion of reinforcement for prestressed concrete and hence, sea water should not be used for making prestressed concrete.

### **Proportioning concrete:**

The process of selection of relative proportions of cement, sand, coarse aggregate and water, so as to obtain a concrete of desired quality is known as *proportioning concrete*. It is observed

that if a vessel, as shown in fig. 7-1, is taken and filled with stones of equal size, voids to the extent of about 45 per cent are formed. This result is independent of the size of stones. It is interesting to note that if sand is taken in place of stones, the same result will be obtained. The result can be verified by pouring water in the vessel, till it is full. The volume of water added in the vessel represents the amount of voids.

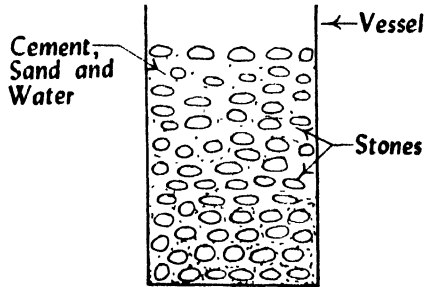

Proportioning concrete

FIG. 7-1

The theory of formation of concrete is based on this phenomena of formation of voids. When coarse aggregate is placed, such voids are formed. When fine aggregate, i.e., sand is added, it occupies these voids. Further, when finely powdered cement is added, it occupies the voids of sand particles. Finally, when water is added, it occupies very fine voids between the cement particles. During the process of setting, a chemical reaction takes place between water and cement. This results in an absolutely solid substance, known as *concrete*.

In general, the proportions of coarse aggregate, fine aggregate, cement and water should be such that the resulting concrete has the following properties:

- (1) When concrete is fresh, it should have enough workability so that it can be placed in the form-work economically.
- (2) The concrete must possess maximum density or in other words, it should be the strongest and most watertight.
- (3) The cost of materials and labour, required to form concrete, should be minimum.

There are various methods for determining the volumetric proportions of various components of concrete. But the methods of arbitrary volumetric proportions and fineness modulus are the most commonly used.

In the method of arbitrary volumetric proportions, the proportions of cement, sand and coarse aggregate are fixed arbitrarily such as 1:2:4 or 1:3:6 etc., depending on the nature of work for which concrete is required. Usually, fine coarse ratio is 1:2, on the assumption that most of the coarse aggregates have voids to the extent of about 50 per cent. Other ratios may also be used.

In the fineness modulus method, the fineness modulus of sand and aggregates is determined by standard tests. The term fineness modulus is used to indicate the mean size of the particle in the entire quantity of aggregates. The standard tests for determining fineness modulus are carried out with the help of B.S.S. sieves. It is found from various experiments that certain values of fineness modulus for fine and coarse aggregates and mixed aggregates give better workability with less quantity of cement. Hence the fineness modulus of aggregates in a given sample of concrete is studied with respect to the desirable value of fineness modulus of aggregate and suitable adjustment is then recommended. The aggregates are mixed in such a proportion that the recommended fineness modulus of combined aggregates is obtained.

The requirements of placing of concrete determine the workability of concrete. The recommended mixes of concrete for various types of construction are given in table 7-2. The maximum size of coarse aggregate is also mentioned in the table. The proportions are by volume.

### **Grading of aggregates:**

In order to obtain concrete of denser quality, fine and coarse aggregates are properly graded. The grading of fine aggregates is expressed in terms of B.S. test sieves 4.7625 mm, Nos. 7, 14, 25, 52 and 100. The grading of coarse aggregates is expressed in terms of B.S. test sieves ranging from 38.10 mm to 4.7625 mm.

The sand to be used for concrete work should conform to the grading limits given in table 7-2.

**TABLE 7-2**  
RECOMMENDED MIXES OF CONCRETE

Proportion of concrete mix	Maximum size of aggregate	Nature of work
1:1:2	12 to 20 mm	Heavily loaded R.C.C. columns and R.C.C. arches of long span.
1:2:2	12 to 20 mm	Small pre-cast members of concrete such as poles for fencing telegraphs, etc., long piles, watertight constructions and heavily stressed members of the structures.
1:2:3 or 1:1½:3½	20 mm	Water tanks, concrete deposited under water, bridge construction and sewers.
1:2½:3½	25 mm	Footpaths and road work.
1:2:4	40 mm	For all general R.C.C. work in building such as stair, beam, column, weather shed, slab, lintel, etc., machine foundations subjected to vibrations, R.C.C. piles.
1:3:5	50 mm	Mass concrete work in culverts, retaining walls, etc.
1:4:8	60 mm	Mass concrete work for heavy walls, foundation footings, etc.

**TABLE 7-3**  
GRADING LIMITS OF SAND

B.S. test sieve	Percentage by weight passing through sieve
4.7625 mm	100
7 no.	71 to 80
14 no.	47 to 65
25 no.	27 to 50
52 no.	11 to 34
100 no.	0 to 7

**TABLE 7-4**  
GRADING OF COARSE AGGREGATES

B.S. test sieve	Percentage by weight passing through sieve	
	For concrete 1:1½:3 to 1:3:6	For concrete 1:2:4
38.10 mm	100	100
19.05 mm	41 to 70	57
9.525 mm	15 to 25	26
4.7625 mm	0	0

The grading of coarse aggregates is to be varied with the concrete mix. But in general, it should conform, as nearly as possible, to the grading limits, mentioned in table 7-4.

### **Water-cement ratio:**

Water in concrete has to perform *two* functions:

- (1) Water enters into chemical action with cement and this action causes setting and hardening of concrete.
- (2) Water lubricates the aggregates and it facilitates the passage of cement through voids of aggregates. This means that water makes the concrete workable.

It is found theoretically that water required for these two functions is about 0.50 to 0.60 times the weight of cement. This ratio of the amount of water to the amount of cement by weight is termed as *water-cement ratio* and the strength and quality of concrete primarily depends upon this ratio. The important points to be observed in connection with water-cement ratio are:

- (1) Minimum quantity of water should be used to have reasonable degree of workability. Excess water occupies space in concrete and on evaporation, voids are created in concrete. Thus excess water affects considerably the strength and durability of concrete. In general, it may be stated that addition of one extra litre of water to concrete of one bag of cement will reduce its strength by about 15 kg/cm<sup>2</sup>.
- (2) Water-cement ratio for structures which are exposed to weather should be carefully decided. For instance, for structures which are regularly wetting and drying, water-cement ratio by weight should be 0.45 and 0.55 for thin sections and mass concrete respectively. For structures which are continuously under water, water-cement ratio by weight should be 0.55 and 0.65 for thin sections and mass concrete respectively.
- (3) Some rules-of-thumb are developed for deciding the quantity of water in concrete. Two such

rules are mentioned below. The rules are for ordinary concrete and they assume that the materials are non-absorbent and dry.

- (i) Weight of water = 28% of the weight of the cement + 4% of the weight of total aggregate.
- (ii) Weight of water = 30% of the weight of the cement + 5% of the weight of total aggregate.

### **Workability:**

The term *workability* is used to describe the ease or difficulty with which the concrete is handled, transported and placed between the forms with minimum loss of homogeneity. If the concrete mixture is too wet, coarse aggregates settle at the bottom of concrete mass and the resulting concrete becomes of non-uniform composition. On the other hand, if the concrete mixture is too dry, it will be difficult to handle and place it in position. Both these conflicting conditions should be correlated by proportioning carefully various components of concrete mixture. The important facts in connection with workability are:

- (1) If more water is added to attain the required degree of workmanship, it results into concrete of low strength and poor durability.
- (2) If the strength of concrete is not to be affected, the degree of workability can be obtained:
  - (i) by slightly changing the proportions of fine and coarse aggregates, in case the concrete mixture is too wet; and
  - (ii) by adding a small quantity of water cement paste in the proportion of original mix, in case the concrete mixture is too dry.
- (3) A concrete mixture for one work may prove to be too stiff or too wet for another work. For instance, stiff concrete mixture will be required in case of vibrated concrete work while wet concrete mixture

will be required for thin sections containing reinforcing bars.

- (4) The workability of concrete is also affected by the maximum size of the coarse aggregates to be used in the mixture.

In order to measure the workability of concrete mixture, various tests are developed. Tests such as flow test and compacting test are used in great extent in laboratory. Slump test, which is commonly used in the field, is briefly described below.

### *Slump test:*

The standard slump cone, as shown in fig. 7-2, is placed on the ground. The operator holds the cone firmly by standing on the foot pieces. The cone is filled with about

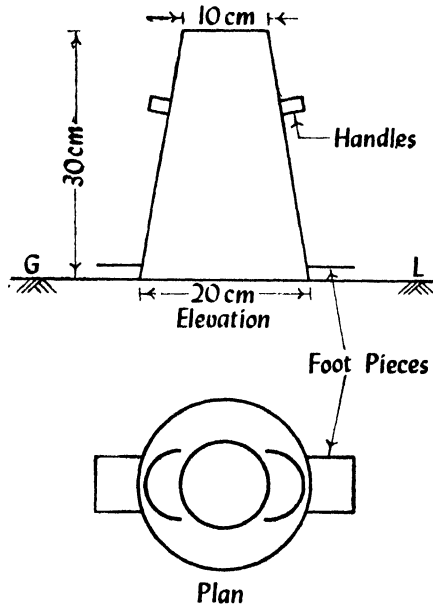

Slump cone

FIG. 7-2

one-fourth portion and then rammed with a rod which is provided with bullet nose at the lower end. The diameter of the rod is 16 mm and its length is 60 cm. The strokes to

be given for ramming vary from 20 to 30. The remaining portion of the cone is filled in with similar layers and then, the top of concrete surface is struck off, so that the cone is completely full of concrete. The cone is then gradually raised vertically and removed. The concrete is allowed to subside and then, height of concrete is measured. Slump of concrete is obtained by deducting height of concrete after subsidence from 30 cm. Table 7-5 shows the recommended slumps of concrete for various types of concrete.

**TABLE 7-5**  
**RECOMMENDED SLUMPS OF CONCRETE**

Sr.No.	Type of concrete	Slump
1.	Concrete for road construction	20 to 40 mm
2.	Concrete for tops of curbs, parapets, piers, slabs and walls that are horizontal	40 to 50 mm
3.	Concrete for canal linings	70 to 80 mm
4.	Concrete for arch and side walls of tunnels	90 to 100 mm
5.	Normal R.C.C. work	80 to 150 mm
6.	Mass concrete	25 to 50 mm
7.	Concrete to be vibrated	10 to 25 mm

### **Estimating yield of concrete:**

The amount of concrete formed from a concrete mix depends on various factors such as water-cement ratio, size of aggregates, compaction, etc. But a rule-of-thumb, as given below, may be used to find the approximate yield of concrete from a given concrete mix.

If the proportion of concrete is  $a:b:c$ , i.e., if  $a$  parts of cement,  $b$  parts of sand and  $c$  parts of coarse aggregates are mixed by volume, the resulting concrete will have a volume of  $\frac{2}{3} (a + b + c)$ .

The yield of concrete can be determined more accurately by considering the absolute volumes of various components of concrete plus the volume of entrapped air. In well compacted concrete, the volume of entrapped air is less than 1 per cent and therefore, it can be neglected.

Let  $w$ ,  $a$ ,  $b$  and  $c$  be absolute volumes of water, cement, fine aggregate and coarse aggregate respectively. Then,  $w + a + b + c = 1$ . The value of absolute volume can be obtained by the relations:

$$\text{absolute volume} = \frac{\text{weight of the materials}}{\text{apparent sp. gr.} \times \text{unit wt of water}}$$

*Problem:*

Estimate the yield of concrete per bag of cement for a concrete mix of proportion (1:2:4).

*Solution:*

(1) *By rule-of-thumb:*

A bag of cement contains  $0.035 \text{ m}^3$  of cement

$$\begin{aligned} \therefore \text{Yield of concrete of proportion (1:2:4)} \\ &= \frac{2}{3}(0.035 + 2 \times 0.035 + 4 \times 0.035) \\ &= 0.163 \text{ m}^3. \end{aligned}$$

(2) *By absolute volumes:*

Assume the following:

Cement	Sp. gr. 3.15 and wt in each bag 50 kg.
Sand	Sp. gr. 2.65 and unit wt 1600 kg/m <sup>3</sup> , when dry
Coarse aggregate	Sp. gr. 2.80 and unit wt 1500 kg/m <sup>3</sup> , when dry.
Water-cement ratio	0.60 times wt of cement.
Unit wt of water	1000 kg/m <sup>3</sup> .

Then,

$$\begin{aligned} \text{Absolute volume of cement} &= \frac{50}{3.15 \times 1000} = 0.02 \text{ m}^3 \\ \text{Absolute volume of sand} &= \frac{2 \times 0.035 \times 1600}{2.65 \times 1000} = 0.04 \text{ m}^3 \\ \text{Absolute volume of coarse aggregate} &= \frac{4 \times 0.035 \times 1500}{2.80 \times 1000} = 0.07 \text{ m}^3 \\ \text{Absolute volume of water} &= \frac{0.60 \times 50}{1 \times 1000} = 0.03 \text{ m}^3 \\ \text{Total} &= 0.16 \text{ m}^3 \end{aligned}$$

### Importance of bulking of sand:

The phenomena of bulking of sand is discussed in previous chapter. The important facts in connection with the bulking of sand are:

- (1) When moisture content is increased by adding more water, the sand particles pack near each other and the amount of bulking of sand is decreased. Thus, the dry sand and the sand completely flooded with water have practically the same volume.
- (2) The coarse aggregate is little affected by moisture content.
- (3) One of the reasons of adopting proportioning by weight is the bulking of sand as proportioning by weight avoids the difficulty due to bulking of sand.
- (4) Bulking of sand should be taken into account when volumetric proportioning of the aggregates is adopted. Otherwise, less quantity of concrete per bag of cement will be produced, which naturally will increase the cost of concrete. Also, there will be less quantity of fine aggregate in the concrete mix which may make the concrete difficult to place. Let the bulking of sand be 25%. Then, if the concrete is of proportion 1:2:4, the actual volume of sand to be used will be  $1.25 \times 2 = 2.50$  instead of 2 per unit volume of cement. If this correction is not applied, the actual dry sand in the concrete will be  $\frac{1}{1.25} \times 2 = 1.60$ , instead of 2 per unit volume of cement. The proportion of concrete will then be 1:1.60:4. This indicates that less quantity of concrete will be produced and in most cases, there will not be enough quantity of fine aggregate to give a workable mix.

### Mixing the materials of concrete:

Materials of concrete should be mixed thoroughly so that there is uniform distribution of materials in the mass of concrete. The thorough mixing also ensures that cement

water paste completely covers the surfaces of aggregates. Mixing of materials of concrete can be done either with hand or with the help of a machine.

### ***Hand mixing:***

For hand mixing, the materials are stacked on a water-tight platform, which may be either of wood, brick or steel. The materials should be thoroughly mixed, at least three times, in dry condition before water is added. The prepared mix should be consumed in 30 minutes after adding water. Mixing by hand is allowed in case of small works or unimportant works where small quantity of concrete is required. For important works, if hand mixing is to be adopted, it is advisable to use 10 per cent more cement than specified.

### ***Machine mixing:***

For machine mixing, all the materials of concrete including water, are collected in a revolving drum and then, the drum is rotated for a certain period. The resulting mix is then taken out of the drum. The features of machine mixing are:

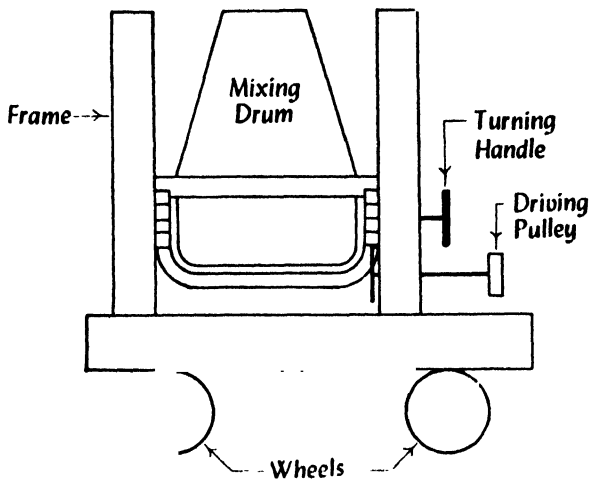

Concrete mixer

FIG. 7-3

- (1) It is found that mixing the materials of concrete with the help of machines is more efficient and it produces concrete of better quality in a short time.

- (2) Mixers of various types and capacities are available in the market. They may either be of tilting type or non-tilting type. They are generally provided with power-operated loading hoppers. For small works, a mixer capable of producing concrete of one bag of cement, is used. For works such as roads, aerodromes, dams, etc., special types of mixers are used. Fig. 7-3 shows a typical concrete mixer.
- (3) Water should enter the mixer at the same time or before the other materials are placed. This ensures even distribution of water.
- (4) The concrete mixer should be thoroughly washed and cleaned after use. If this precaution is not taken, cakes of hardened concrete will be formed inside the mixer. These cakes are not only difficult to remove at a later stage, but they considerably affect the efficiency of the mixer.
- (5) The inside portion of the mixer should be inspected carefully at regular intervals. The damaged or broken blades should be replaced.
- (6) Time of mixing the materials in the mixer and the speed of the mixer are very important factors in deciding the strength of concrete which is formed. The mixing time should be at least one minute and preferably two minutes. The mixer should be rotated at a speed recommended by the makers of the mixer.
- (7) The concrete discharged by the mixer should be consumed within 30 minutes.

### **Transporting and placing of concrete:**

Concrete, as it comes out of the mixer or as it is ready for use on the platform, is to be transported and placed on the formwork. The type of equipment to be used for transport of concrete depends on the nature of work, height above ground level and distance between the points of preparation and placing of concrete. For ordinary building works, human ladder is formed and concrete is conveyed in pans

from hand to hand. For important works, various mechanical devices such as dumpers, truck mixers, buckets, chutes, belt conveyors, pumps, hoist, etc. may be used. The *two* important precautions necessary in transportation of concrete are as follows:

- (i) The concrete should be transported in such a way that there is no segregation of the aggregates.
- (ii) Under no circumstances, water should be added to the concrete during its passage from the mixer to the formwork.

The precautions to be taken during the placing of concrete are as follows:

- (1) The formwork or the surface which is to receive fresh concrete, should be properly cleaned, prepared and well-watered.
- (2) It is desirable to deposit concrete as near as practicable to its final position.
- (3) Large quantities of concrete should not be deposited at a time. Otherwise, the concrete will start to flow along the formwork and consequently, the resulting concrete will not have uniform composition.
- (4) Concrete should be dropped vertically from a reasonable height. For vertical laying of concrete, care should be taken to use stiff mix. Otherwise bleeding of concrete through cracks in forms will take place. The term *bleeding* is used to mean the diffusion or running of concrete through formwork.
- (5) Concrete should be deposited in horizontal layers of about 15 cm height. For mass concrete, the layers may be of 40 cm to 50 cm height. The accumulation of excess water in the upper layers is known as *laitance* and it should be prevented by using shallow layers with stiff mix or by putting dry batches of concrete to absorb the excess water.
- (6) As far as possible, concrete should be placed in single thickness. In case of deep sections, concrete should be placed in successive horizontal layers and proper care should be taken to develop enough bond between successive layers.

- (7) Concrete should be thoroughly worked around the reinforcement and tapped in such a way that no honeycombed surface appears on removal of the formwork. The term *honeycomb* is used to mean comb or mass of waxy cells formed by bees, in which they store their honey. Hence, if this precaution is not taken, the concrete surface so formed would have a honeycomb like surface.
- (8) Concrete should be placed on the formwork as soon as possible. But in no case, it should be placed after 30 minutes of its preparation.
- (9) During placing, it should be seen that all edges and corners of concrete surface remain unbroken, sharp and straight in line.
- (10) The placing of concrete should be carried out uninterrupted between predetermined construction joints.

### **Consolidation of concrete:**

The main aim of consolidation of concrete is to eliminate air bubbles and thus, to give maximum density to concrete. An intimate contact between concrete and reinforcement is ensured by proper consolidation. The importance of consolidation of concrete can be seen from the fact that a presence of 5% of voids reduces 30% strength of concrete. The process of consolidation of concrete can be carried out either with hand or with the help of vibrators.

### ***Hand consolidation:***

For unimportant works, consolidation of concrete is carried out by hand methods which include ramming, tamping, spading and slicing with suitable tools. Hand methods require use of a fairly wet concrete.

### ***Vibrators:***

These are mechanical devices which are used to compact concrete in the formwork. The *advantages* of vibrators over hand methods are as follows:

- (i) It is possible by means of vibrators to make a harsh and stiff concrete mix, with a slump of about 40 mm or less, workable.
- (ii) Quality of concrete can be improved by use of vibrators as less water will be required or in other words, economy can be achieved by adopting a leaner mix when vibrators are used.
- (iii) With the help of vibrators, it is possible to deposit concrete in small openings or places where it will be difficult to deposit concrete by hand methods.

Following are the *four* types of vibrators:

- (1) Internal vibrators
- (2) Surface vibrators
- (3) Form vibrators
- (4) Vibrating tables.

(1) *Internal vibrators:*

These vibrators consist of a metal rod which is inserted in fresh concrete. The rod vibrates while it is being inserted. Internal vibrators should be inserted and withdrawn slowly and they should be operated continuously while they are being withdrawn. Otherwise holes will be formed inside the concrete. Hence, skilled and experienced men should handle internal vibrators. These vibrators are more efficient than other types of vibrators.

(2) *Surface vibrators:*

These vibrators are mounted on platform or screeds. They are used to finish concrete surfaces such as bridge floors, road slabs, station platform, etc.

(3) *Form vibrators:*

These vibrators are attached to the formwork and external centering of walls, columns, etc. The vibrating action is conveyed to concrete through the formwork during transmission of vibrations. Hence they are not generally used. But they are very much helpful for concrete sections which are too thin for the use of internal vibrators.

(4) *Vibrating tables:*

These are in the form of a table and concrete is placed on this table. The vibration of table then brings down the consolidation of concrete. These vibrators are widely used for making pre-cast products.

**Curing of concrete:**

***Meaning of the term:***

Concrete surfaces are kept wet for a certain period after placing of concrete. This is termed as *curing of concrete*.

***Purposes:***

- (1) Curing protects concrete surfaces from sun and wind.
- (2) Presence of water is essential to cause the chemical action which accompanies the setting of concrete. Normally, there is an adequate quantity of water at the time of mixing to cause hardening of concrete. But it is necessary to retain water until the concrete has fully hardened.
- (3) The strength of concrete gradually increases with age, if curing is efficient. This increase in strength is sudden and rapid in early stages and it continues slowly for an indefinite period.
- (4) By proper curing, durability and impermeability of concrete are increased and shrinkage is reduced.
- (5) Resistance of concrete to abrasion is considerably increased by proper curing.

***Period of curing:***

This depends on the type of cement and nature of work. For ordinary portland cement, the curing period is about 7 to 14 days. If rapid hardening cement is used, curing period can be considerably reduced.

***Methods of curing:***

The methods of curing are largely dependent on the nature of work, weather conditions and economy considerations. They can be divided broadly into *two* categories:

- (1) For vertical surfaces, curing is difficult. It is generally done by spraying water at intervals after formwork is removed. Wooden formwork should be coated with oil from inside and during hot season, water should be sprayed to the outside of formwork. Alternatively, the exposed surface of concrete may be covered with hanging canvass which may be maintained wet.
- (2) For horizontal surfaces such as road slab, floors, etc., curing can be done by spraying, ponding or covering the concrete with moist earth, sand or wet gunny bags. For flat horizontal surfaces, ponding is an effective method and it consists of little earthen dams which are built over the entire surface to be cured. The squares thus formed are then flooded with water to a depth of about 50 mm or so. To prevent evaporation, the surface of fresh concrete may be covered with an impervious membrane.

### **Water-proofing cement concrete:**

Cement concrete to a certain extent may be made impermeable to water by using hydrophobic cement. All the flat roofs in the modern age are generally constructed of R.C.C. It becomes necessary to give some treatment of water-proofing to such roofs. Following are the *three* methods adopted for water-proofing of R.C.C. flat roofs:

- (1) Finishing
- (2) Bedding concrete and flooring
- (3) Mastic asphalt and jute cloth.

#### **(1) Finishing:**

For ordinary buildings of cheap construction, finishing of roof surface is done at the time of laying cement concrete. The finishing of flat roof is carried out in cement mortar of proportion 1:4, i.e., one part of cement to four parts of sand by volume.

### (2) *Bedding concrete and flooring:*

In this method, the surface of R.C.C. slab is kept rough and on this surface, a layer of concrete is laid. The concrete may be brickbats lime concrete (1:2:4) or brickbats cement concrete (1:8:14). The thickness of the concrete layer is about 10 cm. The surface of the bedding concrete is provided by a suitable flooring such as tiles, terrazo, Indian patent stone, etc. A convex joint is provided at the junction of parapet wall and roof.

### (3) *Mastic asphalt and jute cloth:*

In this method, a layer of hot mastic asphalt is laid on the roof surface. Jute cloth is spread over this layer. Then one more layer of mastic asphalt is applied so that the jute cloth is sandwiched between the two layers of mastic asphalt. Sand is then sprinkled over the entire surface of roof. For better grip, lead sheets are inserted at the junction of parapet wall and roof.

### **Coloured concrete:**

Concrete can be made coloured in the following ways:

- (1) By addition of suitable colouring pigments to the extent of about 8 to 10% of the weight of cement.
- (2) By using coloured cement for the preparation of cement concrete.
- (3) By selecting aggregates possessing the required colour.

Coloured concrete is used for the following *purposes*:

- (1) manufacture of items for public welfare;
- (2) ornamental finishes in buildings;
- (3) preparing park lanes;
- (4) separating lines on traffic lines on road surfaces;
- (5) underground pedestrian crossings; etc.

### **Lightweight concrete:**

The bulk density of ordinary concrete is about 2300 kg/m<sup>3</sup>. Concrete having bulk density between 500 to 1800

kg/m<sup>3</sup> is known as lightweight concrete and it is prepared from the following materials:

(1) *Binding material*: Ordinary portland cement and its varieties can be used as binding material. If local binding material such as lime-slag, lime-cinder, etc. is available, the same can also be adopted as binding material.

(2) *Aggregates*: For lightweight concretes, loose porous materials are used as aggregates. Natural porous aggregates can be obtained by crushing lightweight rocks. Artificial porous aggregates can be obtained from industrial wastes.

(3) *Steel*: Lightweight concrete is highly porous and hence, it leads to corrosion of reinforcement, if not properly protected. Hence lightweight concrete should be made adequately dense when used for R.C.C. work. Sometimes the reinforcement is coated with anti-corrosive compounds, when lightweight concrete is adopted.

(4) *Water*: It is necessary to use pure drinking water to prepare lightweight concrete. The strength of lightweight concrete mainly depends on the amount of water in the mix. Water-cement ratio for achieving optimum strength of lightweight concrete should be carefully worked out. As water content reaches to its optimum value, there is corresponding increase in the strength of lightweight concrete.

Following are the *advantages* of lightweight concrete:

(1) Local industrial waste, if found suitable for lightweight concrete, can be economically utilised.

(2) The reduction in weight of concrete helps easy removal, transport and erection of pre-cast products.

(3) The use of lightweight concrete results in the reduction of cost to the extent of about 30 to 40% or so.

### **Joints:**

Following are the *two* types of joints which are to be provided in concrete structures:

(1) Construction joints

(2) Expansion and contraction joints.

**(1) Construction joints:**

These joints are made between portions of concrete constructed at different times. The construction joints may be horizontal (fig. 7-4) or vertical (fig. 7-5).

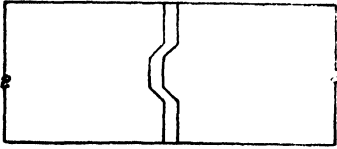

Horizontal construction joint

FIG. 7-4

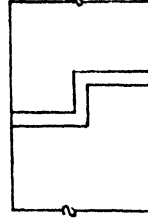

Vertical construction joint

FIG. 7-5

Following points should be kept in view, in case of construction joints:

- (i) Columns should be filled with concrete to a level few centimetres below the junction of a beam.
- (ii) Construction joints should be located at points of the least bending moment and shear force.
- (iii) In case of T-beams, ribs should be filled with concrete first and the slabs forming the flanges can be filled upto the centre of the rib, as shown in fig. 7-6.

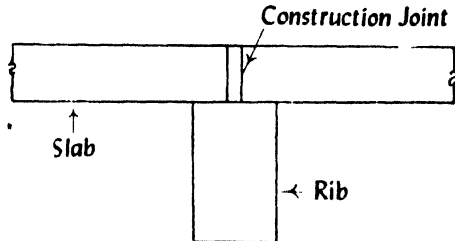

Construction joint

FIG. 7-6

- (iv) For water tanks and other structures which store water, copper or galvanised iron strips, known as

water stops, are placed in a construction joint as shown in fig. 7-7. One-half of the water stop is inserted when the concrete is placed and the other-half is left projecting to be covered up by the next stage of concreting.

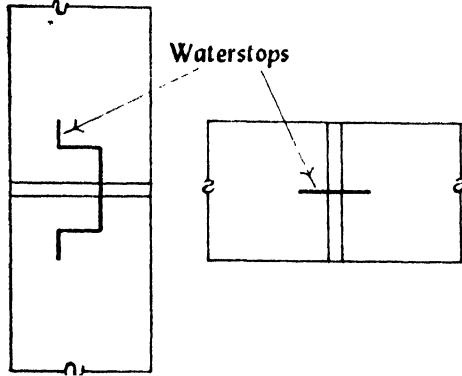

Side floor of a water tank

FIG. 7-7

- (v) Curing of horizontal construction joint should be suspended a few hours before new concreting is started. The surface of construction joint should be thoroughly cleaned and treated with cement plaster or cement sand mortar.

## (2) *Expansion and contraction joints:*

These joints are provided in all concrete structures of length exceeding 12 metres, mainly for *two* purposes:

- (i) to allow changes in volume of concrete due to temperature, and
- (ii) to preserve the appearance and the original shape of the concrete structures.

These joints generally consist of some elastic material, known as *joint filler* and *dowels* or *keys*.

The joint filler should be compressible, rigid, cellular and resilient. In cold weather, it should not become brittle and it should be easy to handle. The usual joint fillers are built-in strips of metal, bitumen-treated felt, cane fibre-board, cork

bound with rubber or resin, dehydrated cork, natural cork, soft wood free from knots, etc.

The dowels or keys are provided in these joints to transfer the load.

### **Guniting:**

The guniting is the most effective process of repairing concrete work which has been damaged due to inferior work or other reasons. It is also used for providing an impervious layer.

Guniting is a mixture of cement and sand, the usual proportion being 1:3. A cement gun is used to deposit this mixture on the concrete surface under a pressure of about 2 to 3 kg/cm<sup>2</sup>. Cement is mixed with slightly moist sand and then necessary water is added as the mixture comes out from the cement gun. A regulating valve is provided to regulate the quantity of water.

The surface to be treated is cleaned and washed. The nozzle of gun is generally kept at a distance of about 75 cm to 85 cm from the surface to be treated and velocity of nozzle varies from 120 to 160 m/sec.

Following are the *advantages* of guniting:

- (1) High compressive strength is obtained. A strength of about 560 to 700 kg/cm<sup>2</sup> at 28 days is generally obtained.
- (2) High impermeability is achieved.
- (3) The repairs are carried out in any situation in a short time.

### **Formwork:**

Concrete is contained in a timber or steel casing for a certain period after its placing. This casing is known as *shuttering, centering, formwork* or *moulds* and it is to be removed when concrete has hardened sufficiently to support its own weight. Following precautions should be taken for formwork of concrete:

- (1) Formwork should be designed in such a way that it can be easily removed and used again.
- (2) Formwork should be fixed in such a way that the least hammering is required for its removal. Otherwise it may injure the concrete.
- (3) Inside surface of formwork should be coated with crude oil or soft soap solution. This will make removal of formwork easy.
- (4) Formwork should be sufficiently strong to bear the dead load of wet concrete as well as the impact of ramming or vibrating the concrete.

### **Pre-cast concrete:**

The main difference between pre-cast concrete and cast-in-situ concrete is that the former is a factory made product while the latter is prepared at site of work. It is possible to prepare well-made pre-cast products by keeping a high standard of finishing. Pre-cast products vary from simple structures such as fencing posts, pipes, paving slabs, etc. to elaborate and complicated artificial concrete blocks. Procedure for preparing pre-cast products is as follows:

- (1) Moulds, which may be of timber, steel or sand, are prepared to the shape of the product.
- (2) Reinforcement, if any, is put up in the moulds as per design.
- (3) Concrete is mixed in the desired proportion and placed in the moulds.
- (4) Finishing of the products is then carried out. Ordinary products such as fence-posts, sleepers, etc. are left as they are, while products such as spun pipes are finished during the process of manufacture.
- (5) The products are then sufficiently cured in specially constructed tanks.
- (6) The products are then dispatched for use at site of work. They may be lifted and placed in position by means of light overhead cranes and small mobile cranes.

***Advantages:***

- (1) Concrete of superior quality is produced as it is possible to have better technical control on the production of concrete in factory.
- (2) It is not necessary to provide joints in pre-cast construction.
- (3) The labour required in the manufacturing process of pre-cast units can easily be trained.
- (4) The moulds employed for preparing the pre-cast units are of steel with exact dimensions in all directions. These moulds are more durable and they can be used several times.
- (5) The pre-cast articles may be given the desired shape and finish with accuracy.
- (6) The pre-cast structures can be dismantled, when required and they can then be suitably used elsewhere.
- (7) The transport and storage of various components of concrete for cast-in-situ work are eliminated when pre-cast members are adopted.
- (8) The work can be completed in a short time, when pre-cast units are adopted.
- (9) When pre-cast structures are to be installed, it is evident that the amount of scaffolding and form-work is considerably reduced.

***Disadvantages:***

- (1) If not properly handled, the pre-cast units may be damaged during transport.
- (2) It becomes difficult to produce satisfactory connections between the pre-cast members.
- (3) It is necessary to arrange for special equipment for lifting and moving of pre-cast units.
- (4) The economy achieved in pre-cast construction is partially balanced by the amount to be spent in

transport and handling of pre-cast members. It becomes, therefore, necessary to locate the pre-cast factory at such a place that transport and handling charges are brought down to the minimum possible extent.

### QUESTIONS

1. Define cement concrete and mention its properties.
2. What are the materials used in making an R.C.C. work?
3. What is meant by proportioning of concrete? Discuss the theory of formation of concrete.
4. State the proportion of concrete, you will recommend, for the following works:
  - (1) Arch
  - (2) Culvert
  - (3) Footpath
  - (4) Lintel
  - (5) Pile
  - (6) Sewer
  - (7) Slab
  - (8) Stair
  - (9) Water tank.
5. Define and explain workability of concrete.
6. How will you estimate the yield of concrete of a given mix? Illustrate your answer by working out the yield of a concrete mix of proportion (1:2:4).
7. Describe in detail what is meant by bulking of sand.
8. How is concrete transported and what are the precautions to be taken during the placing of concrete?
9. How is consolidation of concrete achieved?
10. Write short notes on the following:
  - (1) Formwork for concrete
  - (2) Grading of aggregates
  - (3) Machine mixing of concrete
  - (4) Methods of curing
  - (5) Vibrators
  - (6) Water-cement ratio
  - (7) Admixtures
  - (8) Coloured concrete.

11. What is meant by curing of concrete? What are its purposes? Explain its methods.
12. Explain, with neat sketches, the types of joints which are to be provided in concrete structures.
13. What is guniting? Explain the process of guniting and mention its advantages.
14. Explain the process of corrosion of steel in concrete. Mention its causes.
15. State the effect of corrosion of steel in concrete and suggest preventive measures to avoid it.
16. Can sea water be used for making concrete?
17. Describe the methods adopted for determining the volumetric proportions of various components of concrete.
18. What is slump test of concrete? How is it carried out? Mention recommended slumps for concrete for different purposes.
19. How is water-proofing of cement concrete done?
20. What is meant by lightweight concrete? What are its advantages?
21. How are pre-cast concrete products prepared?
22. Mention advantages and disadvantages of pre-cast concrete.
23. Differentiate between the following:
  - (1) Fine aggregates and coarse aggregates
  - (2) Corrosion and rusting
  - (3) Hand mixing and machine mixing
  - (4) Internal vibrators and surface vibrators
  - (5) Form vibrators and vibrating tables
  - (6) Honeycombing, laitance and bleeding
  - (7) Pre-cast concrete and cast-in-situ concrete
  - (8) Construction joint and contraction joint.
24. Give reasons for the following:
  - (1) It is proved that cement concrete is more economical than steel.
  - (2) The aggregates should be completely free from lumps of clay, organic and vegetable matter, fine dust, etc.

- (3) It is not advisable to use sea water for making prestressed concrete.
- (4) The presence of moisture in sand increases the volume of sand.
- (5) The admixtures are sometimes added in concrete.
- (6) Water makes the concrete workable.
- (7) Minimum quantity of water should be used to have reasonable degree of workability.
- (8) More water should not be added to attain the required degree of workability.
- (9) After use, the concrete mixer should be thoroughly washed and cleaned.
- (10) Sea water can be adopted for concrete structures where finishing characteristics are not important.
- (11) The theory of formation of concrete is based on the phenomena of formation of voids.
- (12) When concrete is fresh, it should have enough workability.
- (13) In the method of arbitrary volumetric proportions, fine coarse ratio of 1:2 is usually adopted.
- (14) Bulking of sand should be taken into account when volumetric proportioning of the aggregates is adopted.
- (15) Large quantities of concrete should not be deposited on the formwork at a time.
- (16) Internal vibrators should be operated continuously while they are being withdrawn.
- (17) Lightweight concrete should be made adequately dense when used for R.C.C. work.
- (18) The dry sand and the sand completely flooded with water have practically the same volume.
- (19) The inside surface of formwork should be coated with crude oil or soft soap solution.
- (20) For concrete structures, exceeding 12 m in length, expansion and construction joints are provided.
- (21) Cement concrete has attained the status of a major building material in all branches of modern construction.

# Chapter 8

## TIMBER

### Definition:

The word *timber* is derived from an old English word, '*timbrian*' which means to build. Timber thus denotes wood which is suitable for building or carpentry or various other engineering purposes. Following *three* terms are to be noted in connection with timber:

(1) *Converted timber* :

This indicates timber which is sawn and cut into suitable commercial sizes.

(2) *Rough timber* :

This indicates timber which is obtained after felling a tree.

(3) *Standing timber* :

This indicates timber contained in a living tree.

Timber or wood, as a building material, possesses a number of valuable properties such as low heat conductivity, amenability to mechanical working, small bulk density, relatively high strength, etc. However, it has also its own drawbacks such as susceptibility to decay and inflammability, fluctuations in properties due to changes in moisture content, variations in strength in length and across fibres, etc. These shortcomings of timber can greatly be reduced by the application of some of the modern wood processing techniques.

At present, it has become possible to have effective utilisation of wood waste, e.g., sawdust and shavings are used with admixture of organic glues to make fibre-slabs, fibre-boards, etc. In addition to the above, wood is also used in the manufacture of various other products such as organic acids, rosin, paper, cardboard, cellulose, etc. Thus the consumption of wood in building industry should be carried out in the best possible economic way.

### Classification of trees:

For the engineering purposes, trees are classified according to their mode of growth. Following is the classification:

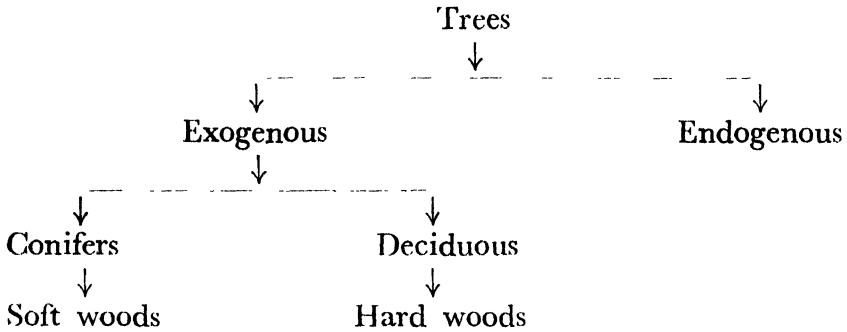

#### (1) *Exogenous trees:*

These trees increase in bulk by growing outwards and distinct consecutive rings are formed in the horizontal section of such a tree. These rings are known as *annual rings* and they are useful in predicting the age of tree. Timber which is mostly used for engineering purposes belongs to this category.

Exogenous trees are further subdivided into *two* groups -- conifers and deciduous.

Conifers are also known as *ever-green trees* and leaves of these trees do not fall till new ones have grown. As these trees bear cone-shaped fruits, they are given the name conifers. These trees yield soft woods.

Deciduous trees are also known as *broad-leaf trees* and leaves of these trees fall in autumn and new ones appear in spring season. Timber for engineering purposes is mostly derived from deciduous trees. These trees yield hard woods.

#### Soft woods and hard woods:

Soft woods form a group of ever-green trees. Hard woods form a group of broad-leaf trees. It is to be noted that the terms soft woods and hard woods have commercial importance only. It is quite likely that some variety of soft wood may prove to be stronger than some variety of hard wood. Table 8-1 is prepared to show points of differences between soft woods and hard woods.

**TABLE 8-1**  
COMPARISON OF SOFT WOODS AND HARD WOODS

Sr.No.	Item	Soft woods	Hard woods
1.	Annual rings	Distinct	Indistinct
2.	Colour	Light	Dark
3.	Fire resistance	Poor	More
4.	Medullary rays	Indistinct	Distinct
5.	Strength	Strong for direct pull and weak for resisting thrust or shear	Equally strong for resisting tension, compression and shear
6.	Structure	Resinous and split easily	Non-resinous and close-grained
7.	Weight	Light	Heavy

Examples of soft woods are chir, deodar, fir, kail, pine, etc. and those of hard woods are ash, beach, oak, sal, teak, etc.

### (2) *Endogenous trees:*

These trees grow inwards and fibrous mass is seen in their longitudinal sections. Timber from these trees has very limited engineering applications. Examples of endogenous trees are bamboo, cane, palm, etc.

### Structure of a tree:

Fig. 8-1 shows the cross-section of an exogenous tree. A tree basically consists of *three* parts, namely, trunk, crown and roots. The function of the trunk is to support the crown and to supply water and nutrients from the roots to leaves through branches and from the leaves back to the roots. Roots are meant to implant the trees in the soil, to absorb moisture and the mineral substances it contains and to supply them to the trunk.

From the visibility aspect, the structure of a tree can be divided into *two* categories:

- I. Macrostructure
- II. Microstructure.

#### *I. Macrostructure:*

The structure of wood visible to the naked eye or at a small magnification is called macrostructure. Fig. 8-1 shows the macrostructure of an exogenous tree. Following are its different components:

(1) *Pith:*

The innermost central portion or core of the tree is called the *pith*. It varies in size and shape for different types of trees.

(2) *Heart wood:*

The inner annular rings surrounding the pith is known as *heart wood*. It is usually dark in colour. As a matter of fact, it indicates dead portion of tree and as such, it does not take active part in the growth of tree. But it imparts rigidity to tree and hence, it provides strong and durable timber for various engineering purposes.

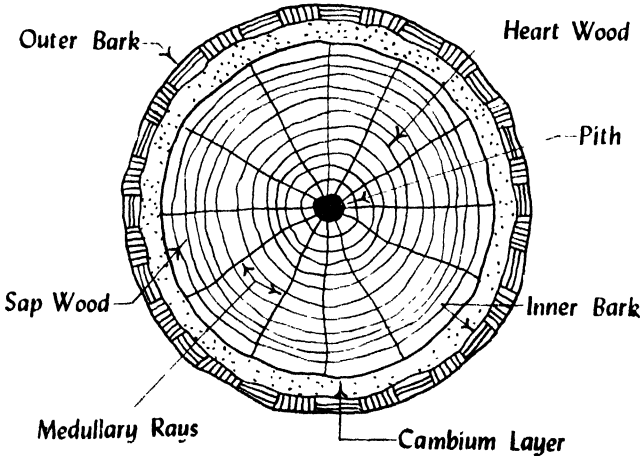

Cross-section of an exogenous tree

FIG. 8-1

(3) *Sap wood:*

The outer annular rings between heart wood and cambium layer is known as *sap wood*. It is usually light in colour and weight. It indicates recent growth and it contains sap. The annular rings of sap wood are less sharply defined than those of heart wood. It takes active part in the growth of tree and sap moves in an upward direction through it. Sap wood is also known as *alburnum*.

(4) *Cambium layer:*

The thin layer of sap between sap wood and inner bark is known as *cambium layer*. It indicates sap which has yet not been converted into sap wood.

(5) *Inner bark:*

The inner skin or layer covering the cambium layer is known as *inner bark*. It gives protection to cambium layer from any injury.

(6) *Outer bark:*

The outer skin or cover of the tree is known as *outer bark*. It is the outermost protective layer and it sometimes contains cracks and fissures. It consists of cells of wood fibre and is also known as *cortex*.

(7) *Medullary rays:*

The thin radial fibres extending from pith to cambium layer are known as *medullary rays*. The function of these rays is to hold together the annual rings of heart wood and sap wood. These rays are sometimes broken and in some varieties of trees, they are not very prominent.

**II. Microstructure:**

The structure of wood apparent only at great magnifications is called microstructure. When studied under a microscope, it becomes evident that wood consists of living and dead cells of various sizes and shapes.

A living cell consists of *four* parts, namely, membrane, protoplasm, sap and core. Cell membrane consists mainly of cellular tissue and cellulose. Protoplasm is a granular, transparent, viscous vegetable protein composed of carbon, hydrogen, oxygen, nitrogen and sulphur. Core of cell differs from protoplasm merely by the presence of phosphorous and it is generally oval.

Cells, according to the functions they perform, are classified into *three* categories:

- (1) Conductive cells
- (2) Mechanical cells
- (3) Storage cells.

(1) *Conductive cells:*

These cells serve mainly to transmit nutrients from roots to branches and leaves.

(2) *Mechanical cells:*

These cells are elongated, thick-walled and have tightly interconnected narrow interior cavities. These cells impart strength to the wood.

(3) *Storage cells:*

These cells serve to store and transmit nutrients to living cells in the horizontal direction and they are usually located in the medullary rays.

**Felling of trees:**

To get timber, trees are knocked down or cut down or caused to fall to the ground. This is known as *felling of trees*. The important facts to be remembered in connection with felling of trees are:

(1) *Age of trees for felling:*

Trees should be felled when they have just matured or when they are very near to maturity. If they are felled before they have attained maturity, sap wood would be in excess and timber obtained from such trees would not be durable. On the other hand, it is also not desirable to fell trees after they have fully matured as heart wood starts decaying after maturity. The age of good trees for felling varies from 50 to 100 years.

(2) *Method of felling:*

Trees should be felled by experienced persons. A cut is made at the bottom of tree and it is extended beyond the centre of gravity of cross-section of tree. Another parallel cut is made above the first cut and by suitably swinging the ropes or cables to which tree is tied down, the tree is felled on the ground. Various appliances required in the process of felling of trees include axes, ropes, saws, wedges, wire cables, etc.

(3) *Season for felling:*

Trees should be felled when sap is at rest. Season for felling of trees should be carefully determined by keeping in view the climatic conditions of the locality and type of trees. In autumn and spring, sap is in vigorous motion and hence, felling of trees in these seasons should be avoided.

For hilly areas, mid-summer would be the proper season for felling as there is heavy rainfall in winter. For plain areas, mid-winter would be the proper season for felling as in summer, water contained in sap would be easily evaporated and it will lead to the formation of cracks.

### **Defects in timber:**

Defects occurring in timber are grouped into following *five* divisions:

- (1) Defects due to conversion
- (2) Defects due to fungi
- (3) Defects due to insects
- (4) Defects due to natural forces
- (5) Defects due to seasoning.

Various types of defects under each category will now be briefly discussed.

#### **(1) *Defects due to conversion:***

During the process of converting timber to commercial form, the following defects may occur:

- (i) Chip mark
- (ii) Diagonal grain
- (iii) Torn grain
- (iv) Wane.

#### **(i) *Chip mark:***

This defect is indicated by the marks or signs placed by chips on the finished surface of timber. They may also be formed by the parts of a planing machine.

#### **(ii) *Diagonal grain:***

This defect is formed due to improper sawing of timber. It is indicated by diagonal mark on straight grained surface of timber.

#### **(iii) *Torn grain:***

This defect is caused when a small depression is formed on the finished surface of timber by falling of a tool or so.

(iv) *Wane* :

This defect is denoted by the presence of original rounded surface on the manufactured piece of timber.

(2) *Defects due to fungi* :

Fungi are minute microscopic plant organisms. They attack timber only when the following *two* conditions are satisfied simultaneously:

- (i) The moisture content of timber is above 20 per cent.
- (ii) There is presence of air and warmth for the growth of fungi.

If any of the above condition is absent, decay of wood due to fungi would not occur. Hence, drywood having moisture content less than 20 per cent will remain sound for centuries. Similarly, wood submerged in water will not be attacked by fungi because of absence of air. Following defects are caused in timber by fungi:

- (i) Blue stain
- (ii) Brown rot
- (iii) Dry rot
- (iv) Heart rot
- (v) Sap strain
- (vi) Wet rot
- (vii) White rot.

(i) *Blue stain* :

Sap of wood is stained to bluish colour by the action of certain type of fungi.

(ii) *Brown rot* :

The term rot is used to indicate decay or disease of timber. Certain types of fungi remove cellulose compounds from wood and hence, wood assumes the brown colour. This is known as *brown rot*.

(iii) *Dry rot* :

Certain types of fungi feed on wood and during feeding, they attack on wood and convert it into dry powder form. This is known as *dry rot*. Following facts in connection with dry rot are to be noted:

- (a) Dry rot occurs at places where there is no free circulation of air such as improperly ventilated basements, rooms, etc.
- (b) Unseasoned soft woods and sap wood are easily attacked by dry rot.
- (c) If timber is not properly stored after being felled down, it is liable for the attack of dry rot.
- (d) It is not necessary to have damp conditions for the development of dry rot.
- (e) Dry rot is also caused by charring, painting and tarring the unseasoned timber.
- (f) Dry rot may be prevented by using well-seasoned timber free from sap.
- (g) When part of timber is affected by dry rot, the damaged portion may be completely removed and the remaining unaffected portion should be painted with a solution of copper sulphate.

(iv) *Heart rot:*

This is formed when a branch has come out of a tree. In such a case, heart wood is exposed to the attack of atmospheric agents. Ultimately, the tree becomes weak and it gives out hollow sound when struck with a hammer.

(v) *Sap stain:*

Certain types of fungi do not bring about the complete decay of timber. But they feed on cell contents of sap wood. In doing so, sap wood loses its colour. This is known as *sap stain* and it generally occurs when moisture content goes beyond 25 per cent or so.

(vi) *Wet rot:*

Some varieties of fungi cause chemical decomposition of wood of the timber and in doing so, they convert timber into a greyish brown powder. This is known as *wet rot*. The important facts to be remembered in connection with wet rot are:

- (a) Alternate dry and wet conditions favour the development of wet rot.

- (b) If unseasoned or improperly seasoned timbers are exposed to rain and wind, they become easily liable for the attack of wet rot.
- (c) To prevent wet rot, well-seasoned timber should be used for exterior work or for underground work and it should be covered by tar or paint for protection against moisture.

(vii) *White rot:*

This defect is just the opposite of brown rot. In this case, certain types of fungi attack lignin of wood and wood assumes the appearance of a white mass consisting of cellulose compounds.

(3) *Defects due to insects:*

Following are the insects which are usually responsible for the decay of timber:

- (i) Beetles
- (ii) Marine borers
- (iii) Termites.

(i) *Beetles:*

These are small insects and they cause rapid decay of timber. They form pin-holes of size about 2 mm diameter in wood. They attack the sapwood of all species of hard woods. Tunnels are formed in all directions in sapwood by the larvae of these beetles. The timber is converted into fine flour-like powder. They usually do not disturb the outer shell or cover. Hence, timber piece attacked by beetles may look sound till it completely fails.

(ii) *Marine borers:*

These are generally found in salty waters. Most of the varieties of marine borers do not feed on wood. But they make holes or bore tunnels in wood for taking shelter. The diameter and length of these holes may go as high as 25 mm and 60 mm respectively. The wood attacked by marine borers loses colour and strength. It may be noted that no timber is completely immune from the attack of marine borers.

(iii) *Termites:*

These are popularly known as *white ants* and they are found in abundance in tropical and sub-tropical countries.

These insects live in a colony and they are very fast in eating away the wood from core of the cross-section. They make tunnels inside the timber in different directions and usually do not disturb the outer shell or cover. Hence, timber piece attacked by termites may look sound till it completely fails. Very few good timbers such as teak, sal, etc. can resist the attack of white ants. Such timbers have certain chemicals in their composition and the smell of these chemicals is not favourable for termites.

**(4) Defects due to natural forces:**

The main natural forces responsible for causing defects in timber are *two*, namely, *abnormal growth* and *rupture of tissues*. Following defects are caused by these forces:

- (i) Burls
- (ii) Callus
- (iii) Chemical stain
- (iv) Coarse grain
- (v) Dead wood
- (vi) Druxiness
- (vii) Foxiness
- (viii) Knots
- (ix) Rind galls
- (x) Shakes
- (xi) Twisted fibres
- (xii) Upsets
- (xiii) Water stain
- (xiv) Wind cracks.

(i) *Burls*:

These are also known as *excrescences* and they are particularly formed when a tree has received shock or injury in its young age. Due to such injury, the growth of tree is completely upset and irregular projections appear on the body of timber.

(ii) *Callus*:

It indicates soft tissue or skin which covers the wound of a tree.

(iii) *Chemical stain*:

Wood is sometimes discoloured by the chemical action

caused with it by some external agency. This is known as *chemical stain*.

(iv) *Coarse grain*:

If a tree grows rapidly, annual rings are widened. It is known as *coarse grained timber* and such timber possesses less strength.

(v) *Dead wood*:

Timber which is obtained from dead standing trees contains dead wood. It is indicated by light weight and reddish colour.

(vi) *Druxiness*:

This defect is indicated by white decayed spots which are concealed by healthy wood. They are probably formed for the access of fungi.

(vii) *Foxiness*:

This defect is indicated by red or yellow tinge in wood. It is caused either due to poor ventilation during storage or by commencement of decay due to over-maturity.

(viii) *Knots*:

These are the bases of branches or limbs which are broken or cut off from the tree. The portion from which the branch is removed receives nourishment from the stem for a pretty long time and it ultimately results in the formation of dark, hard rings which are known as *knots*. As continuity of wood fibres is broken by knots, they form a source of weakness. Fig. 8-2 shows a typical knot.

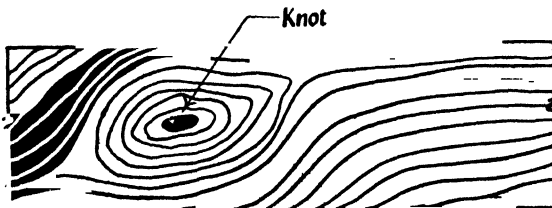

Knot  
FIG. 8-2

Knots are classified on the basis of their size and form. Table 8-2 shows the classification of knots on the basis of their size.

**TABLE 8-2**  
CLASSIFICATION OF KNOTS ON SIZE BASIS

Sr.No.	Type of knot	Size
1.	Pin knot	Diameter upto 6.50 mm.
2.	Small knot	Diameter between 6.50 and 20 mm.
3.	Medium knot	Diameter between 20 and 40 mm.
4.	Large knot	Diameter greater than 40 mm.

Table 8-3 shows the classification of knots on the basis of their form and quality.

**TABLE 8-3**  
CLASSIFICATION OF KNOTS ON BASIS OF FORM AND QUALITY

Sr.No.	Type of knot	Remarks
1.	Dead knot	The fibres of knot are not properly interconnected with those of surrounding wood. Hence it can be easily separated out from the body of wood. It is not safe to use wood with such a knot for engineering purposes.
2.	Decayed knot	It is also known as an unsound knot and it is formed by the action of fungi on wood.
3.	Live knot	It is also known as a sound knot. It is free from decay and cracks. It is thoroughly fixed in wood and hence it cannot be separated out from the body of wood. Presence of such knots makes wood difficult to plane. However, wood containing such knots can be used for engineering purposes.
4.	Loose knot	It indicates preliminary stage of dead knot. The fibres of knot are not firmly held in the surrounding wood.
5.	Round knot	Cross-section of this type of knot is either round or oval. It is obtained by cutting the knot at right angles to its long axis.
6.	Tight knot	It indicates preliminary stage of live knot. The fibres of knot are firmly held in the surrounding wood.

---

(ix) *Rind galls:*

Rind means bark and gall indicates abnormal growth. Hence peculiar curved swellings found on the body of a tree are known as *rind galls* as shown in fig. 8-3. They develop at points from where branches are improperly cut off or removed.

(x) *Shakes:*

These are cracks which partly or completely separate the fibres of wood. Following are the different varieties of shakes:

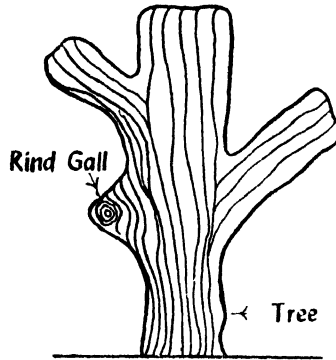

Rind gall  
FIG. 8-3

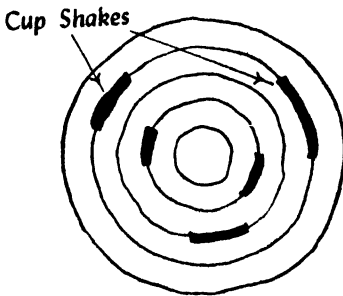

Cup shakes  
FIG. 8-4

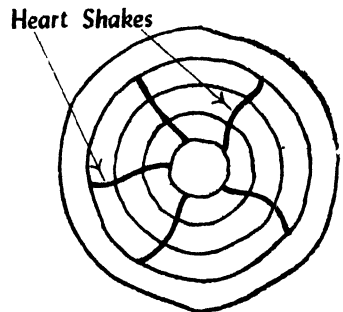

Heart shakes  
FIG. 8-5

(a) *Cup shakes:*

These are caused by the rupture of tissue in a circular direction as shown in fig. 8-4. It is a curved crack and it separates partly one annual ring from the other. It develops due to non-uniform growth. It may not prove to be harmful, if it covers only a portion of ring.

(b) *Heart shakes:*

These cracks occur in the centre of cross-section of tree and they extend from pith to sap wood in the direction of medullary rays as shown in fig. 8-5. These cracks occur due

to shrinkage of interior part of tree which is approaching maturity. Heart shakes divide the tree cross-section into two to four parts.

(c) Ring shakes:

When cup shakes cover the entire ring, they are known as *radial shakes* as shown in fig. 8-6.

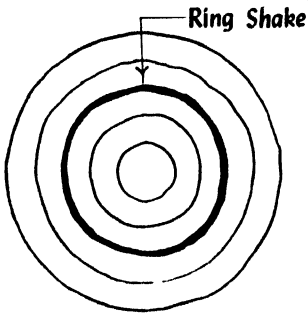

Ring shakes

FIG. 8-6

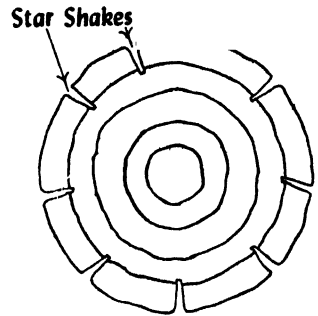

Star shakes

FIG. 8-7

(d) Star shakes:

These are cracks which extend from bark towards the sap wood. They are usually confined upto the plane of sap wood. They are wider on the outside ends and narrower on the inside ends. They are usually formed due to extreme heat or frost. Fig. 8-7 shows star shakes.

(e) Radial shakes:

These are similar to star shakes. But they are fine, irregular and numerous. They usually occur when tree is exposed to sun for seasoning after being felled down. They run for a short distance from bark towards the centre, then follow direction of annual ring and ultimately run towards pith. Fig. 8-8 shows radial shakes.

(xi) *Twisted fibres*:

These are also known as *wandering hearts* and they are caused by twisting of young trees by fast blowing wind. The

fibres of wood are twisted in one direction as shown in fig. 8-9. Timber with twisted fibres is unsuitable for sawing. It can however be used for posts and poles in an unsawn condition.

Radial Shakes

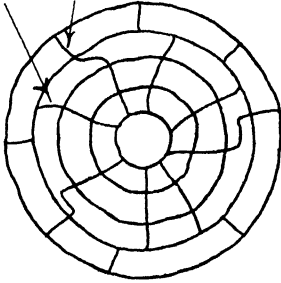

Radial shakes

FIG. 8-8

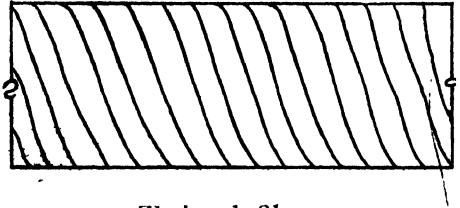

Twisted fibres

FIG. 8-9

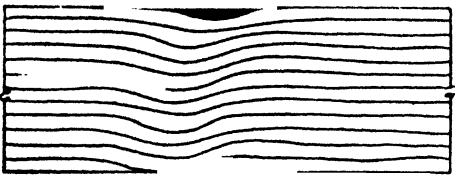

Upset

FIG. 8-10

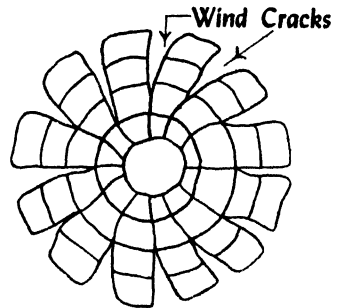

Wind cracks

FIG. 8-11

(xii) *Upsets:*

These are also known as *ruptures* and they indicate wood fibres which are injured by crushing or compression. Fig. 8-10 shows a timber piece with this defect. Upsets are mainly due to improper felling of tree and exposure of tree in its young age to fast blowing wind.

(xiii) *Water stain:*

Wood is sometimes discoloured when it comes into contact with water. This is known as *water stain* and this defect is usually found in converted timber.

(xiv) *Wind cracks:*

If wood is exposed to atmospheric agencies, its exterior surface shrinks. Such a shrinkage results into cracks as shown in fig. 8-11. These are known as *wind cracks*.

(5) *Defects due to seasoning:*

Following defects occur in seasoning process of wood:

- (i) Bow
- (ii) Case-hardening
- (iii) Check
- (iv) Collapse
- (v) Cup
- (vi) Honey-combing
- (vii) Radial shakes
- (viii) Split
- (ix) Twist
- (x) Warp.

(i) *Bow:*

This defect is indicated by the curvature formed in the direction of length of timber as shown in fig. 8-12.



Bow

FIG. 8-12

(ii) *Case-hardening:*

The exposed surface of timber dries very rapidly. It, therefore, shrinks and is under compression. The interior surface which has not completely dried is under tension. This defect is known as *case-hardening* and it usually occurs in timbers which are placed at the bottom during seasoning.

(iii) *Check:*

A check is a crack which separates fibres of wood. It does not extend from one end to the other.

(iv) *Collapse*:

Due to uneven shrinkage, wood sometimes flattens during drying. This is known as *collapse*.

(v) *Cup*:

This defect is indicated by the curvature formed in the transverse direction of timber as shown in fig. 8-13.

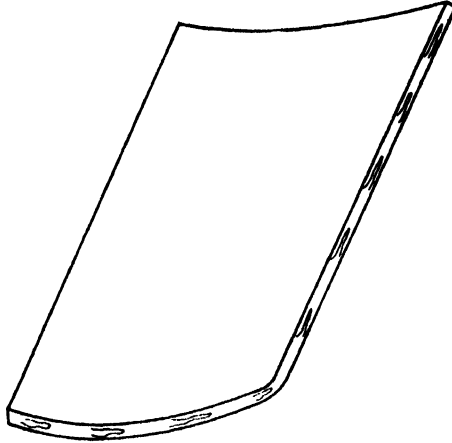

Cup  
FIG. 8-13

(vi) *Honey-combing*:

Due to stresses developed during drying, various radial and circular cracks develop in the interior portion of timber. Timber thus assumes honey-comb texture and the defect so developed is known as *honey-combing*.

(vii) *Radial shakes*:

These are radial cracks. They are explained earlier and are shown in fig. 8-8.

(viii) *Split*:

When a check extends from one end to the other, it is known as a *split*.

(ix) *Twist*:

When a piece of timber has spirally distorted along its length, it is known as *twist*. It is shown in fig. 8-14.

**(x) Warp:**

When a piece of timber has twisted out of shape, it is said to have warped.

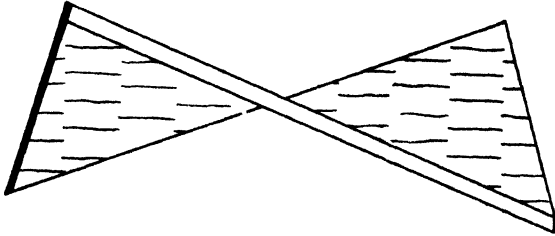

Twist  
FIG. 8-14

**Qualities of good timber:**

Following are the characteristics or qualities of a good timber:

**(1) Appearance:**

A freshly cut surface of timber should exhibit hard and shining appearance.

**(2) Colour:**

The colour of timber should preferably be dark. Light colour usually indicates timber with low strength.

**(3) Defects:**

A good timber should be free from serious defects such as dead knots, flaws, shakes, etc.

**(4) Durability:**

A good timber should be durable. It should be capable of resisting the actions of fungi insects, chemicals, physical agencies and mechanical agencies. If wood is exposed to the actions of acids and alkalis for a prolonged period, it is seriously damaged. Weak alkali and acid solutions usually do not affect wood to a considerable extent.

**(5) Elasticity:**

This is the property by which timber returns to its original shape when load causing its deformation is removed.

This property of timber would be essential when it is to be used for bows, carriage shafts, sport goods, etc.

(6) **Fibres:**

Timber should have straight fibres.

(7) **Fire resistance:**

Timber is a bad conductor of heat. A dense wood offers good resistance to fire and it requires sufficient heat to cause a flame. Heat conductivity of wood is low and it depends on various factors such as porosity, moisture content, surrounding temperature, orientation of fibres, bulk density, etc.

(8) **Hardness:**

A good timber should be hard, i.e., it should offer resistance when it is being penetrated by another body. Chemicals present in heart wood and density of wood impart hardness to timber. Mere resistance offered to chisel or saw does not usually indicate hardness of timber.

(9) **Mechanical wear:**

A good timber should not deteriorate easily due to mechanical wear or abrasion. This property of timber would be essential for places where timber would be subject to traffic, e.g., wooden floors, pavements, etc.

(10) **Shape:**

A good timber should be capable of retaining its shape during conversion or seasoning. It should not bow or warp or split.

(11) **Smell:**

A good timber should have sweet smell. An unpleasant smell indicates decayed timber.

(12) **Sound:**

A good timber should give out a clear ringing sound when struck. A dull heavy sound, when struck, indicates decayed timber. The velocity of sound in wood is 2 to 17 times greater than that in air and hence, wood may be considered high in sound transmission. Sound conductivity is faster along the fibres, is lower in the radial direction and is slowest along the chord of a cross-section.

**(13) Strength:**

A good timber should be sufficiently strong for working as structural member such as joist, beam, rafter, etc. It should be capable of taking loads slowly or suddenly. It should also possess enough strength in direct and transverse directions.

**(14) Structure:**

It should be uniform. Fibres should be firmly added. Medullary rays should be hard and compact. Annular rings should be regular and they should be closely located.

**(15) Toughness:**

A good timber should be tough, i.e., it should be capable of offering resistance to shocks due to vibrations. This property of timber would be essential when it is to be used for tool handles, parts of motor cars and aeroplanes, etc.

**(16) Water permeability:**

A good timber should have low water permeability which is measured by the quantity of water filtered through a unit surface area of specimen of wood. Water permeability is greater along the fibres than in other directions and it depends on initial moisture content, character of cut, type of wood, width of annual rings, age of wood, etc.

**(17) Weathering effects:**

A good timber should be able to stand reasonably the weathering effects. When timber is exposed to weather, its colour normally fades and slowly turns grey. A good timber should show the least disintegration of the surface under adverse weather conditions such as drying and wetting, extreme heat and extreme cold, etc.

**(18) Weight:**

Timber with heavy weight is considered to be sound and strong.

**(19) Working condition:**

Timber should be easily workable. It should not clog the teeth of saw and should be capable of being easily planed or made smooth.

It may be mentioned that the chief factors affecting strength of timber are as follows:

- (i) abnormalities of growth,
- (ii) faults in seasoning,
- (iii) invasion of insects,
- (iv) irregularities of grain,
- (v) moisture content,
- (vi) presence of knots, shakes, etc.,
- (vii) way in which a timber piece is cut from the log, etc.

### **Decay of timber:**

Timber is said to be decayed when it is so deteriorated that it loses its value as an engineering material. Various defects in timber have been mentioned earlier in this chapter. When these defects are in excess, timber decays and such timber is not used for engineering purposes. Following are the various causes or situations which favour the early decay of timber:

- (1) alternate dry and wet conditions,
- (2) bad storage or stacking of timber,
- (3) fungi which are responsible for developing diseases in timber such as blue stain, brown rot, dry rot, heart rot, sap stain, wet rot and white rot,
- (4) improper seasoning,
- (5) insects such as beetles, marine borers, termites, etc.,
- (6) keeping timber in contact with damp wall, damp earth, etc.,
- (7) shocks or impacts received during young age from natural forces such as fast blowing wind, etc.,
- (8) use of timber without taking out sap wood from its structure,
- (9) using seasoned timber without applying suitable preservative on its surface, and
- (10) using unseasoned wood with the application of protective coat of paint or tar.

### **Preservation of timber:**

#### **Object:**

Preservation of timber is carried out to achieve the following *three* objects:

- (1) to increase the life of timber structures,
- (2) to make the timber structures durable, and
- (3) to protect the timber structures from the attack of destroying agencies such as fungi, insects, etc.

***Requirements of a good preservative:***

- (1) It should allow decorative treatment on timber after being applied over timber surface.
- (2) It should be capable of covering a large area with small quantity.
- (3) It should be cheap and easily available.
- (4) It should be durable and should not be affected by light, heat, etc.
- (5) It should be free from unpleasant smell.
- (6) It should be non-inflammable.
- (7) It should be quite efficient in killing fungi, insects, etc.
- (8) It should be safe and harmless for persons and animals.
- (9) It should give pleasant appearance to timber after being applied over it.
- (10) It should not affect the strength characteristics of timber.
- (11) It should not be easily washed away by water.
- (12) It should not corrode the metals with which it comes into contact.
- (13) It should offer high resistance to moisture and dampness.
- (14) Its penetrating power into wood fibres should be high. It is necessary for the preservative to be effective to penetrate at least for a depth of 6 mm to 25 mm.

***Types of preservatives:***

Following preservatives are commonly used for the preservation of timber:

- (1) Ascu treatment
- (2) Chemical salts
- (3) Coal tar

- (4) Creosote oil
- (5) Oil paints
- (6) Solignum paints.

(1) *Ascu treatment* :

Ascu is a special preservative which is developed at the Forest Research Institute, Dehradun. Its composition is as follows:

- 1 part by weight of hydrated arsenic pentoxide,  
( $\text{As}_2\text{O}_5, 2\text{H}_2\text{O}$ ).
- 3 parts by weight of blue vitriol or copper sulphate,  
( $\text{CuSO}_4, 5\text{H}_2\text{O}$ ).
- 4 parts by weight of potassium dichromate,  
( $\text{K}_2\text{Cr}_2\text{O}_7$ ) or sodium dichromate ( $\text{Na}_2\text{Cr}_2\text{O}_7, 2\text{H}_2\text{O}$ ).

This material is available in powder form. To prepare a solution of this material, six parts by weight of ascu are mixed in 100 parts by weight of water. The solution is then sprayed or applied on timber surface. This preservative gives timber protection against the attack of white ants. The surface treated with this preservative can be painted, polished, varnished or waxed.

The other compositions of water soluble preservatives on this line are mentioned in table 8-4.

**TABLE 8-4**  
WATER SOLUBLE PRESERVATIVES

Sr.No.	Name of preservative	Composition
1.	Acid — cupric — chromate composition	1.68 parts of chromic acid ( $\text{CrO}_3$ ), 50 parts of copper sulphate ( $\text{CuSO}_4, 5\text{H}_2\text{O}$ ) and 47.5 parts of sodium dichromate ( $\text{Na}_2\text{Cr}_2\text{O}_7, 2\text{H}_2\text{O}$ ).
2.	Chromated — zinc chloride composition	1 part of zinc chloride ( $\text{ZnCl}_2$ ) and 1 part of sodium dichromate or potassium dichromate ( $\text{Na}_2\text{Cr}_2\text{O}_7, 2\text{H}_2\text{O}$ or $\text{K}_2\text{Cr}_2\text{O}_7$ ).
3.	Copper — chrome — boric composition	1.5 parts of boric acid ( $\text{H}_3\text{BO}_3$ ), 3 parts of copper sulphate ( $\text{CuSO}_4, 5\text{H}_2\text{O}$ ) and 4 parts of sodium dichromate or potassium dichromate ( $\text{Na}_2\text{Cr}_2\text{O}_7, 2\text{H}_2\text{O}$ or $\text{K}_2\text{Cr}_2\text{O}_7$ ).
4.	Zinc — chrome — boric composition	1 part of boric acid ( $\text{H}_3\text{BO}_3$ ), 3 parts of zinc chloride ( $\text{ZnCl}_2$ ) and 4 parts of sodium dichromate ( $\text{Na}_2\text{Cr}_2\text{O}_7, 2\text{H}_2\text{O}$ ).
	Zinc — meta — arsenite composition	3 parts of arsenious trioxide ( $\text{As}_2\text{O}_3$ ), 2 parts of zinc oxide ( $\text{ZnO}$ ) and acetic acid just enough to make the preservative workable.

(2) *Chemical salts:*

These are water-borne preservatives and they are mostly salts dissolved in water. The usual salts used are copper sulphate, mercury chloride, sodium fluoride and zinc chloride.

Solutions are prepared from these salts and they are applied on timber surface. These preservatives are odourless and non-inflammable. The treated surface can be painted or varnished after drying. These preservatives have good penetration and timbers treated with these preservatives will show an immediate increase in weight of 240 to 480 kg per m<sup>3</sup>. After drying, the net increase in weight will come down to about 5 to 30 kg per m<sup>3</sup>.

(3) *Coal tar:*

Timber surface is coated with hot coal tar. The process is known as *tarring*. Coal tar has unpleasant smell and appearance. It makes timber unsuitable for painting. Hence tarring is adopted for frames of doors and windows, rough timber work, etc.

(4) *Creosote oil:*

In this case, timber surface is coated with creosote oil. The process is known as *creosoting*. Creosote oil is obtained by the distillation of tar. Creosoting is carried out as follows:

- (i) Timber is thoroughly seasoned and dried.
- (ii) It is then placed in an air tight chamber.
- (iii) Air is pumped out from the chamber.
- (iv) Creosote oil is then pumped under a high pressure of about 7 to 10 kg/cm<sup>2</sup> and a temperature of about 50°C.
- (v) After a period of about 1 to 2 hours, when timber has sufficiently absorbed creosote oil, it is taken out of chamber.

Creosoting practically doubles the life of timber and it is generally adopted for piles, poles, railway sleepers, etc. Depending upon the net retention and type of timber, creosote treated timber will normally increase in weight by 80 to 320 kg per m<sup>3</sup>.

(5) *Oil paints :*

Timber surface is coated with two or three coats of oil paint. Wood should be seasoned. Otherwise sap will be confined and it will lead to decay of timber. Oil paints preserve timber from moisture and thus make it durable.

(6) *Solignum paints :*

These paints preserve timber from white ants as it is highly toxic in nature. They can be mixed with colour pigments. Timber surface may, therefore, be given the desired colour or appearance.

**Methods :**

Following are the methods adopted for preservation of timber:

- (1) Brushing
- (2) Charring
- (3) Dipping and steeping
- (4) Hot and cold open tank treatment
- (5) Injecting under pressure
- (6) Spraying.

(1) *Brushing :*

The solution prepared from preservative is applied on timber surface by good quality of brushes. This is the simplest method and it is generally adopted for seasoned timber. The cracks should be filled up before the application of preservative. For better penetration, oil type preservatives may be applied hot and the preservative should be liberally used on the surface. Several coats of preservatives may be applied and enough interval of time should be kept between successive coats for absorption of preservative.

(2) *Charring :*

This method of charring is rather very old and as such, no preservative is used in this method. The surface to be charred is kept wet for about half an hour and it is then burnt upto a depth of about 15 mm over a wood fire. The charred portion is then cooled with water. Due to

burning, a layer of coal is formed on the surface. This layer is not affected by moisture and it is not attacked by white ants, fungi, etc. The *disadvantages* of this method are:

- (1) The charred surface becomes black in appearance and hence, it cannot be used for exterior work.
- (2) There is some loss of strength of timber as the cross-section is reduced due to charring.

The process of charring is generally adopted for lower ends of posts for fencing, telephone, etc. which are to be embedded in the ground.

(3) *Dipping and steeping:*

In this method, timber to be given preservative treatment is dipped or soaked for a short period in the solution of preservative. This method gives slightly better penetration of preservative than in case of brushing or spraying. Instead of dipping, steeping or wetting of timber with preservative may be carried out for periods varying from a few hours to days or weeks. The depth of penetration of preservative depends on the type of timber.

(4) *Hot and cold open tank treatment:*

In this method, timber is submerged in a tank containing solution of preservative which is heated for a few hours at temperature of 85°C to 95°C. The tank is then allowed to cool down gradually while the timber is still submerged in the tank. This method is effective in giving protection to sap wood.

(5) *Injecting under pressure:*

In this method, the preservative is injected under pressure into the timber. This method is usually adopted in creosoting. This is the most effective method of treating timber with preservative. But it requires special treatment plant. This method proves to be essential for treating non-durable timbers which are to be used at places where there is danger of attack by fungi and insects.

(6) *Spraying:*

In this method, solution of preservative is filled in a

spraying pistol and it is then applied on timber surface under pressure. The pistol works under compressed air. This method is also quite effective and it is superior to brushing.

### **Fire-resistance of timber:**

As a general rule, structural elements made of timber ignite and get rapidly destroyed in case of a fire. Further, they add to the intensity of a fire. But timber used in heavy sections may attain a high degree of fire-resistance because timber is a very bad conductor of heat. This is the reason why time is required to build up sufficient heat so as to cause a flame in timber.

With respect to fire-resistance, timber is classified as refractory timber and non-refractory timber. The refractory timber is non-resinous and it does not catch fire easily. Examples of refractory timbers are sal, teak, etc. The non-refractory timber is resinous and it catches fire easily. Examples of non-refractory timbers are chir, deodar, fir, etc.

To make timber more fire-resistant, following methods are adopted:

#### **(1) *Application of chemicals:***

Timber surface is coated with the solution of certain chemicals. It is found that two coats of solution of borax or sodium arsenate with strength of 2 per cent are quite effective in rendering the timber fire-resistant.

#### **(2) *Sir Abel's process:***

In this process, timber surface is cleaned and it is coated with a dilute solution of sodium silicate. A cream-like paste of slaked fat lime is then applied and finally, a concentrated solution of silicate of soda is applied on the timber surface. This process is quite satisfactory in making the timber fire-resistant.

### **Seasoning of timber:**

#### ***Meaning:***

When a tree is newly felled, it contains about 50 per cent or more of its oven-dry weight as water. This water is in the

form of sap and moisture. Water is to be removed before timber can be used for any engineering purpose. In other words, timber is to be dried. This process of drying of timber is known as *seasoning of timber*.

Wood is a hygroscopic material. It attains a level of equilibrium moisture content under the given climatic conditions of temperature and relative humidity. By the process of seasoning, the excess water of timber is extracted in such a way that the moisture content of seasoned timber corresponds to the required moisture content in timber for the environments in which it is to be used. The relationship between the climatic conditions and moisture content in timber has been established from tests on various types of timber. It is to be noted that the seasoned timber should be protected from exposure to rain and excessively high humidity.

***Free moisture and bound moisture:***

Moisture in timber can be present either in the cell cavities or in the cell walls. The former is known as free moisture or free water and major part of moisture in timber is present as free water. The latter is known as bound moisture and it is closely associated with the body of timber.

When timber containing moisture is exposed to the atmospheric conditions, it starts losing its moisture content. Free water is evaporated first and the point at which the cell cavities no longer contain free water is known as fibre saturation point. After the fibre saturation point has been reached, the tendency of timber to shrink appears and it is more or less proportional to the loss in bound moisture.

***Determination of moisture content:***

The moisture content of timber is determined as follows:

$$P = \frac{W_1 - W_2}{W_2} \times 100$$

where  $P$  = Percentage of moisture

$W_1$  = Original weight of timber

$W_2$  = Oven-dry weight of timber.

The samples of timber to be tested should be dried in an oven at a temperature of 100°C to 105°C till the dry weight

remains constant. The over-dry method of determining moisture content is a standard method. But for the field observations, electronic instruments are available for readily working out the moisture content of timber.

### **Objects:**

Seasoning of timber is carried out to achieve the following objects:

- (1) To allow timber to burn readily, if used as fuel.
- (2) To decrease the weight of timber and thereby to lower the cost of transport and handling.
- (3) To impart hardness, stiffness and strength to timber.
- (4) To increase the resisting power of timber, as most of the causes of decay of timber are more or less related to moisture.
- (5) To maintain the shape and size of the components of the timber articles which are expected to remain unchanged in form.
- (6) To make timber easily workable and to facilitate operations during conversion.
- (7) To make timber fit for receiving treatment of paints, preservatives, varnishes, etc.
- (8) To make timber safe from the attack of fungi and insects.
- (9) To reduce the tendency of timber to crack, shrink and warp.

### **Methods:**

Methods of seasoning can broadly be divided into the following *two* categories:

- (1) Natural seasoning
- (2) Artificial seasoning.

#### (1) *Natural seasoning:*

In this method, seasoning of timber is carried out by natural air and hence it is also sometimes referred to as air seasoning. Following procedure is adopted in air seasoning:

(i) Timber in log form is not usually fit for the process of seasoning. Hence, it is cut and sawn into suitable sections of planks or scantlings.

(ii) Timber pieces can either be stacked horizontally or vertically, the former arrangement being very common. Fig. 8-15 shows a typical horizontal stack for air seasoning.

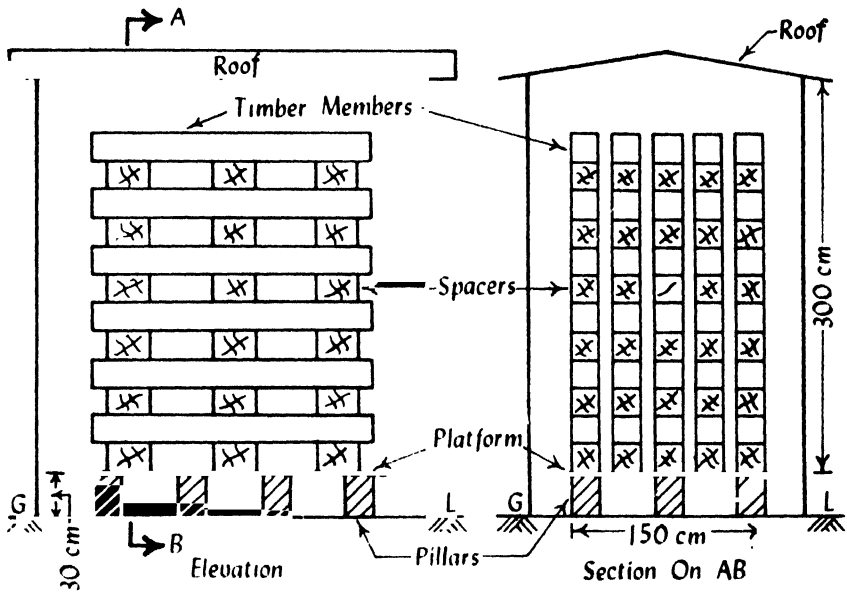

Horizontal stack for air seasoning

FIG. 8-15

(iii) The ground, where stack is to be constructed, is cleared and it is levelled for good drainage.

(iv) The platform of stack is made slightly higher, about 30 cm, than the ground level. For this purpose, rows of brick or concrete pillars are constructed. The pillars may also be made of creosoted wood or wood coated with coal tar. The tops of pillars should be in the same horizontal plane. The pillars should be durable.

(v) The timber pieces are sorted out according to lengths and thicknesses. They are then arranged in layers, one above the other. Care should be taken to see that all members in a particular layer are of the same thickness. If this precaution

is not taken, there are chances for timber to become warped or cracked.

(vi) Each layer is separated by spacers of sound dry wood. The usual dimensions of spacers vary from 35 mm × 25 mm to 50 mm × 35 mm, the larger dimension being the width. The spacers are to be carefully placed in correct vertical alignment.

(vii) The distance between spacers depends on the sizes of timber members to be seasoned. It is less for thin sections and more for thick sections. It usually varies from 45 cm to 60 cm.

(viii) Length of stack is equal to length of timber pieces. Width and height of stack are restricted to about 150 cm and 300 cm respectively. A distance of about 25 mm is kept between adjacent layers.

(ix) The stack is to be protected from fast blowing wind, rain and extreme heat of sun. Hence the stack should preferably be covered by a roof of suitable material.

(x) Similar stacks may be constructed. The minimum distance between adjacent stacks should be at least 60 cm.

#### *Advantages :*

- (i) Depending upon the climatic conditions, the moisture content of wood can be brought down to about 10 to 20 per cent.
- (ii) It does not require skilled supervision.
- (iii) It is uneconomical to provide artificial seasoning to timber sections thicker than 100 mm, as such sections dry very slowly. Hence such thicker timber sections are usually seasoned by the process of air seasoning.
- (iv) This method of seasoning timber is cheap and simple.

#### *Disadvantages :*

- (i) As the process depends on natural air, it sometimes becomes difficult to control it.
- (ii) Drying of different surfaces may not be even and uniform.

- (iii) If ends of thick sections of timber are not protected by suitable moisture-proof coating, there are chances for end splitting because the ends of such timbers dry rapidly in comparison to the central portions.
- (iv) If not properly attended, fungi and insects may attack timber during the process of seasoning and may thereby damage it.
- (v) Moisture content of wood may not be brought down to the desired level.
- (vi) Space required for this process will be more as timber will have to be stacked or stored for a sufficiently long time.
- (vii) The process of seasoning is very slow and it usually takes about 2 to 4 years to make timber fit for the work of carpenter.

(2) *Artificial seasoning:*

Following are the reasons for adopting artificial seasoning to natural seasoning:

- (i) Defects such as shrinkage, cracking and warping are minimised.
- (ii) Drying is controlled and there are practically no chances for the attack of fungi and insects.
- (iii) Drying of different surfaces is even and uniform.
- (iv) It considerably reduces the period of seasoning.
- (v) There is better control of circulation of air, humidity and temperature.
- (vi) Wood becomes more suitable for painting, gluing, etc.
- (vii) Wood with desired moisture content may be obtained by artificial seasoning.

Various methods of artificial seasoning are as follows:

- (i) **Boiling**
- (ii) **Chemical seasoning**
- (iii) **Electrical seasoning**
- (iv) **Kiln seasoning**
- (v) **Water seasoning.**

Each method of artificial seasoning will be now briefly discussed.

(i) Boiling:

In this method of artificial seasoning, timber is immersed in water and water is then boiled. This is a very quick method. Timber is thus boiled with water for about three to four hours. It is then dried very slowly. The period of seasoning and shrinkage are reduced by this method, but it affects the elasticity and strength of wood. In place of boiling water, timber may be exposed to the action of hot steam. This method of seasoning proves to be costly.

(ii) Chemical seasoning:

This is also known as *salt seasoning*. In this method, timber is immersed in a solution of suitable salt. It is then taken out and seasoned in the ordinary way. The interior surface of timber dries in advance of exterior one and chances of formation of external cracks are reduced.

(iii) Electrical seasoning:

In this method, use is made of high frequency alternating currents. Timber, when it is green, offers less resistance to the flow of electric current. The resistance increases as the wood dries internally which also results in the production of heat. This is the most rapid method of seasoning. But initial and maintenance costs are so high that it becomes uneconomical to season timber on commercial base by this method.

(iv) Kiln seasoning:

In this method, drying of timber is carried out inside an air-tight chamber or oven. The process of seasoning is as follows:

- (1) Timber is arranged inside the chamber such that spaces are left for free circulation of air.
- (2) Air which is fully saturated with moisture and which is heated to a temperature of about 35°C to 38°C is then forced inside the chamber by suitable arrangement.

- (3) This forced air is allowed to circulate round the timber pieces. As air is fully saturated with moisture, evaporation from the surfaces of timber pieces is prevented. The heat gradually reaches inside the timber pieces.
- (4) The relative humidity is now gradually reduced.
- (5) The temperature is then raised and maintained till the desired degree of moisture content is attained.

Depending upon the mode of construction and operation, kilns are of *two* types, namely, stationary kilns and progressive kilns.

A *stationary kiln* is also known as a *compartment kiln* and in this kiln, process of seasoning is carried out in a single compartment only. Drying operations are adjusted as drying proceeds. This kiln is adopted for seasoning timber which requires a close control of humidity and temperature. It gives better results.

In a *progressive kiln*, timber travels from one end of kiln to the other and in doing so, it gets seasoned. It is used for seasoning timber on a large scale. If not properly attended, drying in this kiln may prove to be unsatisfactory.

Kiln seasoning, though costly, gives well seasoned timber as it controls *three* important conditions, namely, circulating air, relative humidity and temperature.

(v) Water seasoning:

In this method, the following procedure is adopted:

- (1) Timber is cut into pieces of suitable sizes.
- (2) These pieces are immersed wholly in water, preferably in running water of a stream. Care should be taken to see that timber is not partly immersed.
- (3) The thicker or larger end of timber is kept pointing on the upstream side.
- (4) Timber is taken out after a period of about 2 to 4 weeks. During this period, sap contained in timber is washed away by water.

- (5) Timber is then taken out of water and allowed to dry in free air. Water that has replaced sap from timber dries out and timber is seasoned.

Water seasoning is a quick method and it renders timber which is less liable to shrink or warp. It also removes organic materials contained in sap of timber. It, however, weakens timber and makes it brittle.

***Classification of timbers with respect to seasoning:***

Depending upon the ease with which Indian timbers can be seasoned, they are divided into *three* groups, namely, non-refractory timbers, moderately refractory timbers and highly refractory timbers.

Non-refractory timbers can be rapidly seasoned without any trouble. They can be seasoned even in the open air and sun. Examples are deodar, simul, etc.

Moderately refractory timbers have tendency to split and to crack during seasoning. They are therefore to be protected against rapid drying conditions. Examples are mango, rosewood, sisoo, teak, etc.

Highly refractory timbers are likely to be damaged severely during seasoning. They are difficult to season. Examples are axle wood, hopea, laurel, sal, etc.

The cost of seasoning of timber will naturally depend on the thickness of timber and type of timber with respect to seasoning. It will be more for highly refractory timbers and less for non-refractory timbers.

The period or time for seasoning of timber will also vary with the thickness of timber and type of timber with respect to seasoning. Table 8-5 shows the time required for seasoning of different timbers with different thicknesses.

**TABLE 8-5**  
**TIME FOR SEASONING OF TIMBERS**

Sr.No.	Type of timber	Thickness in mm			
		12	25	38	50
1.	Non-refractory	6 Days	8 Days	12 Days	17 Days
2.	Moderately refractory	7 Days	10 Days	14 Days	18 Days
3.	Highly refractory	9 Days	12 Days	17 Days	22 Days

### Conversion of timber:

The process by which timber is cut and sawn into suitable sections is known as *conversion*. For this purpose, power machines may be employed at different stages of process. Following important facts in connection with conversion of timber are to be remembered:

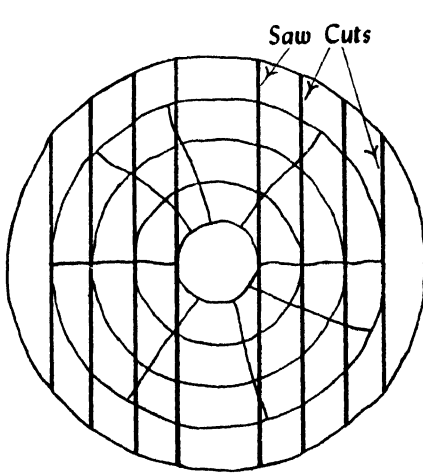

Ordinary sawing  
FIG. 8-16

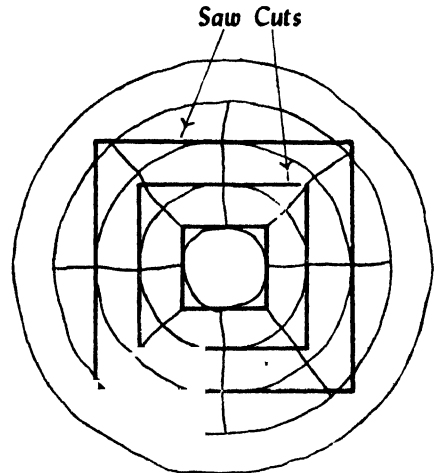

Tangential sawing  
FIG. 8-18

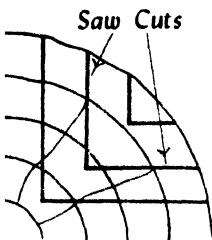

Quarter sawing  
FIG. 8-17

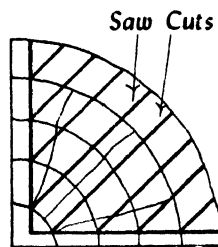

Radial sawing  
FIG. 8-19

(1) Conversion is a skilled art and it should be carried out in such a way that there is minimum wastage of useful timber.

(2) Allowance should be made for shrinkage, squaring and planing. It is about 3 mm to 6 mm.

(3) Wooden beams should be sawn in such a way that they do not contain pith in their cross-section. To achieve this, timber is first sawn through pith into two halves.

(4) To obtain strong timber pieces, the saw cuts should be made tangential to annular rings and practically parallel to the direction of medullary rays

(5) Conversion may be achieved either by ordinary sawing, quarter sawing, tangential sawing or radial sawing as shown in fig. 8-16 to fig. 8-19.

Fig. 8-16 shows ordinary sawing. The saw cuts are tangential to annual rings and right through the cross-section of timber piece. It is the most economical method and wastage of useful timber is minimum.

Fig. 8-17 shows quarter sawing. The saw cuts are at right angles to each other. It may produce fine figurewood.

Fig. 8-18 shows tangential sawing. The saw cuts are tangential to annual rings and they meet each other at right angles.

Fig. 8-19 shows radial sawing. The saw cuts are made radially. This method is used for conversion of hard timber. It gives wood with decorative effect.

### **Storage of timber:**

The structural timber should be properly stored so as to avoid any further development of defects. For the purpose of storage, suitable stacks of timber pieces are formed. The stacks are prepared on similar lines to the stacks for air seasoning as shown in fig. 8-15. The length of stack depends on length of timber pieces. Its width and height are usually limited to about 150 cm and 200 cm respectively. The material is arranged in layers and the layers are separated by wooden battens which are known as crossers or spacers. The stack should be protected from direct sun, dry wind and rain. If necessary, a sloping roof of suitable material may be provided over the stack. The important facts to be remembered for storage of timber are as follows:

- (1) In each layer, an air space of about 25 mm should be maintained between adjacent members.

- (2) The crossers or spacers should be of sound wood, straight and uniform in thickness.
- (3) The ends of all members should be coated with suitable material to prevent end-cracking.
- (4) The longer pieces should be placed in bottom layers and the shorter pieces should be placed in top layers.
- (5) The platform of stack should be made at least 15 cm higher than ground.
- (6) There should be a minimum distance of at least 30 cm between adjacent stacks.

### **Market forms of timber:**

Timber is converted into suitable commercial sizes. Following are various forms in which timber is available in the market:

#### **(1) *Batten:***

This is a timber piece whose breadth and thickness do not exceed 50 mm.

#### **(2) *Baulk:***

It is a roughly squared timber piece and it is obtained by removing bark and sap wood. One of the cross-sectional dimension exceeds 50 mm, while the other exceeds 200 mm.

#### **(3) *Board:***

It is a plank, i.e., a timber piece with parallel sides. Its thickness is less than 50 mm and width exceeds 150 mm.

#### **(4) *Deal:***

It is a piece of soft wood with parallel sides. Its thickness varies from 50 mm to 100 mm and its width does not exceed 230 mm.

#### **(5) *End:***

This is a short piece of batten, deal, scantling, etc.

#### **(6) *Log:***

It is the trunk of tree obtained after removal of branches.

**(7) Plank:**

It is a timber piece with parallel sides. Its thickness is less than 50 mm and its width exceeds 50 mm.

**(8) Pole:**

It is a sound long log of wood. Its diameter does not exceed 200 mm. It is also known as a *spar*.

**(9) Quartering:**

It is a square piece of timber, the length of side being 50 mm to 150 mm.

**(10) Scantling:**

This is a timber piece whose breadth and thickness exceed 50 mm, but are less than 200 mm in length.

**Industrial timber:**

Timber which is prepared scientifically in a factory is termed as industrial timber and such timber possesses desired shape, appearance, strength, etc. Following are the varieties of industrial timber:

- (1) Veneers
- (2) Plywoods
- (3) Fibreboard
- (4) Impreg timbers
- (5) Compreg timbers.

**(I) Veneers:**

These are thin sheets or slices of wood of superior quality. The thickness of veneers varies from 0.40 mm to 6 mm or more. They are obtained by rotating a log of wood against a sharp knife of rotary cutter. Veneers after being removed are dried in kilns to remove moisture. Following points should be noted:

- (1) Edges of veneers are joined and sheets of decorative designs are prepared.
- (2) Indian timbers which are suitable for veneers are mahogany, oak, rosewood, sissoo, teak, etc.

- (3) The process of preparing a sheet of veneers is known as *veneering*.
- (4) Veneers are used to produce plywoods, batten boards and laminboards.
- (5) Veneers may be fixed on corners or bent portions. It creates an impression that the whole piece is made of expensive timber.
- (6) Veneers may be glued with suitable adhesives on the surface of inferior wood. Appearance of inferior wood is then considerably improved.

## (2) *Plywoods*:

The meaning of term *ply* is a thin layer. Plywoods are boards which are prepared from thin layers of wood or veneers. Three or more veneers are placed one above the other with the direction of grains of successive layers at right angles to each other. They are held in position by application of suitable adhesives. The placing of veneers normal to each other increases the longitudinal and transverse strengths of plywoods.

While being glued, pressure may be applied on veneers. The pressure may either be applied hot or cold. For hot pressure, hydraulic press is employed to press plywoods. Temperature varies from 150°C to 260°C. For cold pressure, plywoods are pressed at room temperature only. The pressure applied on plywoods varies from 7 to 14 kg/cm<sup>2</sup>. Plywoods are used for various purposes such as ceilings, doors, furniture, partitions, panelling walls, packing cases, railway coaches, formwork for concrete, etc. Plywoods, however, are not suitable in situations subjected to direct shocks or impacts.

Plywoods are available in different commercial forms such as battenboard, laminboard, metal faced plywood, multi-ply, three-ply, veneered plywood, etc.

Battenboard is a solid block with core of sawn thin wood. Thickness of core is about 20 mm to 25 mm and total thickness of board is about 50 mm.

Laminboard is similar to battenboard except that the core is made of multi-ply veneers. Thickness of each veneer

does not exceed 6 mm and total thickness of board is about 50 mm. External plies are of thick veneers and they are firmly glued with core to form a solid block.

In metal faced plywood, the core is covered by a thin sheet of aluminium, copper, bronze, steel, etc. This plywood is rigid and it is cleaned.

Plywoods prepared from more than three plies are designated as multi-ply. The number of veneers is odd. Thickness may vary from 6 mm to 25 mm or more.

Plywoods prepared from three plies only are known as three-ply. Thickness may vary from 6 mm to 25 mm or more.

In veneered plywood, the facing veneer is of decorative appearance and it is used to develop an ornamental effect.

#### *Advantages of plywoods:*

- (1) As plies are placed at right angles to each other, expansion and shrinkage are comparatively very low.
- (2) They are available in a variety of decorative appearance.
- (3) They are available in large sizes.
- (4) They are elastic and hence they are not liable to split or crack due to changes in atmosphere.
- (5) They are light in weight.
- (6) They are not easily affected by moisture.
- (7) They are very easy to work and they can be made to suit any design.
- (8) They do not split in an axial direction.
- (9) They make use of rare and valuable timbers in a quite economical way.

#### **(3) Fibreboards:**

These are rigid boards and they are also known as *pressed wood* or *reconstructed wood*. The thickness varies from 3 mm to 12 mm. They are available in lengths varying from 3 m to 4.50 m and in widths varying from 1.20 m to 1.80 m. Weight of fibreboards depends on pressure applied during manufacture. The maximum and minimum limits of weight are 960 kg/m<sup>3</sup> and 50 to 60 kg/m<sup>3</sup>.

Following is the procedure adopted in the manufacture of fibreboards:

- (1) The pieces of wood, cane or other vegetable fibres are collected and they are heated in a hot water boiler.
- (2) Wood fibres separated by heat are put in a vessel.
- (3) Steam under pressure is admitted in the vessel.
- (4) The pressure of steam is then suddenly increased to 70 kg/cm<sup>2</sup>. This increased pressure is maintained for few seconds only.
- (5) The valve located at the bottom of vessel is opened and steam is allowed to expand.
- (6) The sudden release of pressure makes the wood pieces to explode and in doing so, the natural adhesive contained in the wood fibres is separated out.
- (7) Wood fibres are then allowed to flow out.
- (8) These fibres are cleaned of all superfluous or extra gums.
- (9) Such cleaned fibres are spread on wire screens in the form of loose sheets or blankets of required thickness.
- (10) Such loose sheets of wood fibres are prepared between steel plates and ultimately, fibreboards are obtained.

Depending upon their form and composition, fibreboards are classified as insulating boards, medium hard boards, hard boards, superhard boards and laminated boards. They are also available under various trade names such as Euraka, Indianite, Insulite, Masonite, Nordex, Trectex, etc.

Following are the *uses* of fibreboards:

- (1) For internal finish of rooms such as wall panelling, suspended ceilings, etc.
- (2) To construct formwork for cement concrete, i.e., to retain cement concrete in position when it is wet.

- (3) To construct partitions.
- (4) To prepare flush doors, tops of tables, etc.
- (5) To provide an insulating material for heat and sound.
- (6) To work as a paving or flooring material.

#### (4) *Impreg timbers:*

Timber which is fully or partly covered with resin is known as impreg timber. The usual resin employed is phenol formaldehyde which is soluble in water. Veneers or thin strips of wood are taken and they are immersed in resin. The resin fills the space between wood cells and by chemical reaction, a consolidated mass develops. It is then cured at a temperature of about 150°C to 160°C. Impreg timber is available under trade names such as Formica, Sungloss, Sunmica, etc.

The *advantages* of impreg timbers are:

- (1) It is not affected by moisture and weather conditions.
- (2) It is strong and durable.
- (3) It possesses more electrical insulation.
- (4) It presents a decent appearance.
- (5) It resists acidic effects.
- (6) The contraction and expansion of impreg timbers are about 25 to 40 per cent less than ordinary timber.

#### (5) *Compreg timbers:*

The process of preparing compreg timbers is same as that of impreg timbers except that curing is carried out under pressure. The strength and durability of compreg timbers are more as compared to the impreg timbers.

#### **Advantages of timber construction:**

Timber has been probably the first material to be adopted in the construction of engineering structures. It possesses the following distinct *advantages* in preference to other engineering materials:

- (1) It can be easily worked with ordinary tools.
- (2) It can be used either for load bearing members or for non-load bearing members.
- (3) It combines light weight with strength.
- (4) It is easy to provide connections in the timber construction.
- (5) It is economical and cheap. This is due to the fact that the smallest piece of wood can be put to one or other use and the wastage of material is thereby considerably minimised.
- (6) It is possible to realise some value even after timber construction has completed its useful life.
- (7) It is used to prepare furniture of decent appearance and comfortable design.
- (8) The heavy timber construction presents a massive appearance.
- (9) The houses with timber construction are found to be cool in summer and warm in winter. This is due to the fact that wood is a non-conductor of heat.
- (10) The other forms of present day such as plywoods, fibreboards, etc. have made timber construction to match with the present day requirements.
- (11) The timber construction is quite durable, if properly protected against moisture, rain, wind, etc.

### **Indian timber trees:**

There are over 150 species of timber which are produced in India. Following are the chief varieties of timber trees which are used for engineering purposes in India:

- |              |                |
|--------------|----------------|
| (1) Aini     | (8) Benteak    |
| (2) Arjun    | (9) Bijasal    |
| (3) Axlewood | (10) Casuarina |
| (4) Babul    | (11) Deodar    |
| (5) Bakul    | (12) Guava     |
| (6) Bamboo   | (13) Gumar     |
| (7) Banyan   | (14) Hopea     |

(15) Indian elm	(28) Red cedar
(16) Ironwood	(29) Rosewood or blackwood
(17) Irul	(30) Sal
(18) Jack	(31) Sandal
(19) Jarul	(32) Satin wood
(20) Kathal	(33) Simul
(21) Laurel	(34) Siris
(22) Mahogany	(35) Sissoo
(23) Mango	(36) Spruce
(24) Mulberry	(37) Sundri
(25) Oak	(38) Tamarind
(26) Palms	(39) Teak
(27) Pine	(40) Toon.

A brief description of each Indian timber tree with its properties and uses will now be given.

**(1) *Aini*:**

Its colour is yellowish brown. It is elastic, close-grained and strong. Its weight at 12 per cent moisture content is  $595 \text{ kg/m}^3$ . It takes polish. It can be used under water. It is found in Maharashtra, Andhra Pradesh, Madras and Kerala.

It is used for ordinary building construction, structural work, paving, furniture, etc.

**(2) *Arjun*:**

Its colour is dark brown. It is heavy and strong. Its weight after seasoning is about  $870 \text{ kg/m}^3$ . It is found in Central India.

It is used for beams, rafters, posts, etc.

**(3) *Axlewood*:**

It is very strong, hard and tough. Its weight at 12 per cent moisture content is  $930 \text{ kg/m}^3$ . It takes a smooth finish. It is liable to cracking. It is found in Andhra Pradesh, Madras, Maharashtra, Madhya Pradesh, Bihar and Uttar Pradesh.

(4) **Babul:**

It is strong, hard and tough. Its colour is whitish red. It takes up a good polish. Its weight after seasoning at 12 per cent moisture content is  $835 \text{ kg/m}^3$ . It is found in Andhra Pradesh, Maharashtra, Madhya Pradesh, Madras, Bengal, Gujarat and Uttar Pradesh.

It is used for bodies and wheels of bullock carts, agricultural instruments, tool handles, etc.

(5) **Bakul:**

Its colour is reddish brown. It is close-grained and tough. It is found in some parts of North India. Its weight after seasoning at 12 per cent moisture content is  $880 \text{ kg/m}^3$ .

It is used for making cabinets.

(6) **Bamboo:**

It is an endogenous tree. It is found in abundance in Assam and Bengal. It is also found in most of the parts of the country.

It is used for scaffolding, thatched roofs, rafters, etc.

(7) **Banyan:**

Its colour is brown. It is strong and durable only under water. Its weight after seasoning is about  $580 \text{ kg/m}^3$ . It is found all over India.

It is used for aerial roots for tent poles, well curbs, etc.

(8) **Benteak:**

It is strong and takes up a smooth surface. Its weight after seasoning at 12 per cent moisture content is  $675 \text{ kg/m}^3$ . It is found in Kerala, Madras and Maharashtra.

It is used for building construction, boat construction, furniture, etc.

(9) **Bijasal:**

Its colour is light brown. It is coarse-grained, durable and strong. It is difficult to work. It is not easily attacked by white ants. Its weight after seasoning at 12 per cent moisture content is  $800 \text{ kg/m}^3$ . It is found in Andhra

Pradesh, Madhya Pradesh, Maharashtra, Kerala, Uttar Pradesh, Madras and Orissa.

It is used for ordinary building construction, cart wheels, etc.

**(10) *Casuarina*:**

Its colour is reddish brown. It grows straight. It is strong and fibrous. It is, however, badly twisted. Its weight at 12 per cent moisture content is  $765 \text{ kg/m}^3$ . It is found in Madras.

It is used for scaffolding, posts for temporary structures, etc.

**(11) *Deodar*:**

Its colour is yellowish brown. It is the most important timber tree providing soft wood. It can be easily worked. It possesses distinct annual rings. It is moderately strong. Its weight after seasoning at 12 per cent moisture content is  $560 \text{ kg/m}^3$ . It is found in Himalayas, Punjab and Uttar Pradesh.

It is used for making cheap furniture, railway carriages, railway sleepers, packing boxes, structural work, etc.

**(12) *Guava*:**

It is fine grained. It is hard, tough and flexible. It is not strong. Its weight after seasoning is about  $750 \text{ kg/m}^3$ . It is practically found all over India.

It is used for making toys, handles of instruments, engraving work, etc.

**(13) *Gumar*:**

Its colour is pale yellow. It can be easily worked. It is strong and durable especially when used under water. Its weight after seasoning is about  $580 \text{ kg/m}^3$ . It is found in Central India and South India.

It is used for furniture, carriage, well curbs, yokes, door panels, etc.

**(14) Hopea:**

Its colour is light to deep brown. It is extremely strong and tough. It is difficult to work. It is durable and not likely to be damaged by white ants. It can be seasoned easily. Its weight after seasoning at 12 per cent moisture content is 1010 kg/m<sup>3</sup>. It is found in Madras and Kerala.

It is used for ordinary house construction, railway sleepers, piles, boat building, etc.

**(15) Indian elm:**

Its colour is red. It is moderately hard and strong. Its weight after seasoning is about 960 kg/m<sup>3</sup>. It is practically found all over India.

It is used for door and window frames, carts, etc.

**(16) Ironwood:**

Its colour is reddish brown. It is durable. It is very hard and is not easily worked. It even resists penetration of nails. Its weight after seasoning is about 1040 kg/m<sup>3</sup>.

It is used for ordinary house construction, bridges, piles, agricultural instruments, railway wagons, railway sleepers, etc.

**(17) Irul:**

It is very hard, heavy and durable. It is difficult to work. It requires slow and careful seasoning. Its weight after seasoning at 12 per cent moisture content is 835 kg/m<sup>3</sup>. It is found in Kerala, Andhra Pradesh, Maharashtra, Orissa and Madras.

It is used for railway sleepers, agricultural instruments, paving blocks, heavy construction, etc.

**(18) Jack:**

Its colour is yellow when freshly cut and it darkens with age. It is compact and even grained. It is moderately strong. It is easy to work. It takes a good finish. It maintains its shape well. Its weight after seasoning at 12 per cent moisture content is 595 kg/m<sup>3</sup>. It is found in Maharashtra and Madras.

It is used for plain furniture, boat construction, well curbs, door panels, cabinet making, etc.

**(19) Jarul:**

Its colour is light reddish grey. It is hard and durable. It can be easily worked. It takes a good finish. Its weight after seasoning at 12 per cent moisture content is  $640 \text{ kg/m}^3$ . It is found in Assam, Bengal and Maharashtra.

It is used for house construction, boat building, railway carriages, cart making, scaffolding, etc.

**(20) Kathal:**

Its colour is yellow to deep brown. It is heavy and hard. It is durable under water and in damp conditions. It cracks, if exposed directly to sun. It is not attacked by white ants. It is found in Andhra Pradesh, Kerala, Maharashtra and Madras.

It is used for piles, platforms of wooden bridges, door and window panels, etc.

**(21) Laurel:**

Its colour is dark brown. It is strong, hard and tough. It is likely to crack and to the attack of dry rot. It is not attacked by white ants. It takes a smooth finish. Its weight after seasoning at 12 per cent moisture content is  $880 \text{ kg/m}^3$ . It is found in Andhra Pradesh, Bihar, Orissa, Madhya Pradesh, Kerala and Madras.

It is used for house construction, boat construction, railway sleepers, structural work, etc.

**(22) Mahogany:**

Its colour is reddish brown. It takes a good polish. It is easily worked. It is durable under water. Its weight after seasoning is about  $720 \text{ kg/m}^3$ .

It is used for furniture, pattern making, cabinet work, etc.

**(23) Mango:**

The mango tree is very well-known for its fruits. Its colour is deep grey. It is easy to work. It maintains its

shape well. It is moderately strong. Its weight after seasoning at 12 per cent moisture content is  $655 \text{ kg/m}^3$ . It is practically found all over India.

It is used for cheap furniture, packing boxes, cabinet work, panels for doors and windows, etc.

**(24) *Mulberry:***

Its colour is brown. It is strong, tough and elastic. It takes up a clean finish. It can be well seasoned. It is turned and carved easily. Its weight after seasoning is about  $650 \text{ kg/m}^3$ . It is found in Punjab.

It is used for baskets, hockey sticks, sport goods and furniture.

**(25) *Oak:***

Its colour is yellowish brown. It is strong and durable. It possesses straight silvery grains. Its weight at 12 per cent moisture content is  $865 \text{ kg/m}^3$ .

It is used for preparing sport goods.

**(26) *Palms:***

It contains ripe wood in the outer crust. The colour of this ripened wood is dark brown. It is strong and durable. It is fibrous. Its weight after seasoning is about  $1040 \text{ kg/m}^3$ . It is found practically all over India.

It is used for furniture, roof covering, rafters, joists, etc.

**(27) *Pine:***

It is hard and tough except white pine which is soft. It decays easily, if it comes in contact with soil. It is heavy and coarse-grained. White pine is light and straight grained.

It is used for pattern making, frames for doors and windows, paving material, etc. White pine is used in the manufacture of matches.

**(28) *Red cedar:***

Its colour is red. It is soft and even grained. Its weight after seasoning is about  $480 \text{ kg/m}^3$ . It is found in Assam and Nagpur.

It is used for furniture, door panels, well curbs, etc.

**(29) Rosewood or blackwood:**

It is dark in colour. It is strong, tough and close-grained. It is handsome and it takes a high polish. It maintains its shape well. It is available in large sizes. Its weight after seasoning is about  $790 \text{ kg/m}^3$ . It is found in Kerala, Maharashtra, Madhya Pradesh, Madras and Orissa.

It is used for furniture of superior quality, cabinet work, ornamental carvings, etc.

**(30) Sal:**

Its colour is brown. It is hard, fibrous and close-grained. It does not take up a good polish. It requires slow and careful seasoning. It is durable under ground and water. Its weight after seasoning at 12 per cent moisture content is  $800 \text{ kg/m}^3$ . It is found in Andhra Pradesh, Maharashtra, Uttar Pradesh, Bihar, Madhya Pradesh and Orissa.

It is used for railway sleepers, ship building, bridges, structural work, etc.

**(31) Sandal:**

Its colour is white or red. It gives a pleasant smell. Its weight after seasoning is about  $930 \text{ kg/m}^3$ . It is found in Assam, Nagpur and Bengal.

It is used for agricultural instruments, well curbs, wheels, mallets, etc.

**(32) Satin wood:**

Its colour is yellow. It is very hard and durable. It is close-grained. Its weight after seasoning is about  $960 \text{ kg/m}^3$ . It is found in Central and Southern India.

It is used for furniture and other ornamental works.

**(33) Simul:**

Its colour is white. It is loose grained. It is an inferior quality of wood. It is light in weight and its weight after seasoning is about  $450 \text{ kg/m}^3$ . It is found practically all over India.

It is used for packing cases, match industry, well curbs, cheap furniture, etc.

**(34) *Siris*:**

Its colour is dark brown. It is hard and durable. It is difficult to work. Its weight after seasoning is about 1040 kg/m<sup>3</sup>. It is found in North India.

It is used for well curbs in salty water, beams, posts, furniture, etc.

**(35) *Sissoo*:**

Its colour is dark brown. It is strong and tough. It is durable and handsome. It maintains its shape well. It can be easily seasoned. It is difficult to work. But it takes a fine polish. Its weight after seasoning at 12 per cent moisture content is 770 kg/m<sup>3</sup>. It is found in Mysore, Maharashtra, Assam, Bengal, Uttar Pradesh and Orissa.

It is used for furniture, plywoods, bridge piles, sport goods, railway sleepers, etc.

**(36) *Spruce*:**

It resists decay. It is not affected by the attack of marine borers. It is liable to shrink, twist and warp. Its weight at 12 per cent moisture content is 480 kg/m<sup>3</sup>.

It is used for piles under water, aeroplanes, etc.

**(37) *Sundri*:**

Its colour is dark red. It is hard and tough. It is difficult to season and work. It is elastic and close-grained. It is strong and durable. Its weight after seasoning at 12 per cent moisture content is 960 kg/m<sup>3</sup>. It is found in Bengal.

It is used for boat building, piles, poles, tool handles, carriage shafts, etc.

**(38) *Tamarind*:**

Its colour is dark brown. It is knotty and durable. Its weight after seasoning is about 1280 kg/m<sup>3</sup>. It is a beautiful tree for avenues and gardens. Its development is very slow. But it ultimately forms a massive appearance. Its

fruits are also very useful. It is found practically all over India.

It is used for agricultural instruments, well curbs, sugar mills, carts, brick burning, etc.

**(39) Teak:**

Its colour is deep yellow to dark brown. It is moderately hard. It is durable and fire-resistant. It can be easily seasoned and worked. It takes a good polish. It is not attacked by white ants and dry rot. It does not corrode iron fastenings. It shrinks little. It is among the most valuable timber trees of the world. Its weight after seasoning at 12 per cent moisture content is  $625 \text{ kg/m}^3$ . It is found in Central India and Southern India.

It is used for house construction, railway carriages, flooring, structural work, ship building, furniture, mallets, agricultural instruments, well curbs, piles, etc.

**(40) Toon:**

Its colour is reddish brown. It can be easily worked. It is light in weight and its weight after seasoning is about  $530 \text{ kg/m}^3$ . It is found in Assam.

It is used for furniture, packing boxes, cabinet making, etc.

## QUESTIONS

1. Define:  
Timber; Soft woods; Hard woods; Pith; Sap wood; Medullary rays; Cambium layer.
2. How are trees classified?
3. Compare soft woods with hard woods.
4. Draw a neat cross-section of an exogenous tree and show various components of it.
5. Explain what is meant by felling of trees.
6. Enumerate various defects in timber.
7. Describe the defects caused in timber due to fungi.
8. What are the forces responsible for causing natural defects in timber? Explain such natural defects of timber.

9. Write short notes on:
- (1) Dry rot and wet rot
  - (2) Termites
  - (3) Rind galls
  - (4) Fire-resistance of timber
  - (5) Teak wood
  - (6) Kiln seasoning
  - (7) Impreg timbers
  - (8) Ascu treatment
  - (9) Radial shakes
  - (10) Veneers.
10. What are knots? How are they classified?
11. Explain different types of shakes.
12. What are the defects caused due to seasoning?
13. Mention the qualities of a good timber.
14. What is meant by decay of timber? What are its causes?
15. What are the objects of preservation of timber? State the requirements of a good preservative.
16. Describe the preservatives which are commonly used in the process of preservation of timber.
17. Discuss the methods adopted for preservation of timber.
18. What is meant by seasoning of timber? What are its objects?
19. Explain the process of natural seasoning. Mention its advantages and disadvantages.
20. Why is artificial seasoning adopted? Describe its various methods.
21. Describe the process of conversion of timber.
22. State the market forms of timber.
23. Write a critical note on veneers.
24. What are plywoods? Mention their advantages.
25. What are fibreboards? How are they manufactured? How are they classified? What are their uses?
26. State the advantages of timber construction.
27. Make a list of chief varieties of Indian trees.
28. Describe the following Indian timber trees:
- |          |             |            |                |
|----------|-------------|------------|----------------|
| (1) Aini | (2) Babul   | (3) Deodar | (4) Hopea      |
| (5) Jack | (6) Jarul   | (7) Mango  | (8) Rosewood   |
| (9) Sal  | (10) Sissoo | (11) Bakul | (12) Mulberry. |

29. Mention water soluble preservatives.
30. How is moisture content of timber determined?
31. How are timbers classified with respect to seasoning?
32. Write a critical note on storage of timber.
33. What is meant by industrial timber? What are its varieties?
34. Give sketches of the following:
  - (1) Rind gall
  - (2) Heart shakes
  - (3) Wind cracks
  - (4) Tangential sawing
  - (5) Horizontal stack for air seasoning.
35. Differentiate between the following:
  - (1) Exogenous trees and endogenous trees
  - (2) Cambium layer and medullary rays
  - (3) Brown rot and white rot
  - (4) Cup shakes and star shakes
  - (5) Free moisture and bound moisture
  - (6) Natural seasoning and artificial seasoning
  - (7) Battenboard and laminboard
  - (8) Impreg timbers and compreg timbers
  - (9) Annual rings and medullary rays
  - (10) Plywood and fibreboard
  - (11) Macrostructure and microstructure
  - (12) Mechanical cells and storage cells.
36. Give reasons for the following:
  - (1) Drywood having moisture content less than 20 per cent will remain sound for centuries.
  - (2) Timber piece attacked by beetles or termites may look sound till it completely fails.
  - (3) Solignum paints preserve timber from white ants.
  - (4) The structural timber should be properly stored.
  - (5) The felling of trees in autumn and spring should be avoided.
  - (6) Timber used in heavy sections may attain a high degree of fire-resistance.
  - (7) Plywoods are not liable to split or crack due to changes in temperature.
  - (8) The consumption of wood in building industry should be carried out in the best possible economic way.

# Chapter 9

## FERROUS METALS

### General:

Metals are also employed for various engineering purposes such as structural members, roofing materials, damp-proof courses, pipes, tanks, doors, windows, etc. Out of all the metals, iron is the most popular metal and it has been used in construction activity since pre-historic times. It is also available in abundance and it is estimated that it constitutes about 4.60 per cent of the earth's crust. As a matter of fact, it is contained in the green leaves of plants and it forms the red colouring matter of blood of animals.

In Latin, iron is known as *ferrum* and its chemical designation is Fe. For the purpose of study, metals will be grouped in the following *two* categories:

- (1) Ferrous metals
- (2) Non-ferrous metals.

Ferrous metals contain iron as their main constituent. There are *three* important ferrous metals, namely, cast-iron, wrought-iron and steel.

Non-ferrous metals do not contain iron as their main constituent. Some of the non-ferrous metals such as aluminium, copper, etc. have limited use for engineering purposes.

In this chapter, study of cast-iron and wrought-iron will be made. Steel and non-ferrous metals will be discussed in the subsequent chapters.

### Iron ores:

#### *Definition:*

An ore may be defined as a solid naturally occurring mineral aggregate, of economic interest, from which, one or more valuable constituents may be recovered by certain treatment. Iron ores are thus compounds of iron with non-

metallic elements and they contain impurities such as carbon, manganese, phosphorus, silicon and sulphur. The term *gangue* is used to indicate substances occurring along with ores.

### ***Selection of iron ores:***

Iron ores are taken out or extracted from earth by mining operations. While selecting the site for such mines, the following points should be carefully examined:

- (1) Iron ores available from mines should be rich in metallic iron content. For ores containing less percentage of metallic iron, considerable amount of coke and flux will be required and it will not be economical to manufacture iron from such ores.
- (2) Mines for iron ores should be located suitably in both ways — geographically and geologically. By geographical location, it is meant that the mines should be easily accessible and they should be linked up with surrounding towns by suitable transport facilities. By geological location, it is meant that site for mines should not contain conditions which might develop complications in quarrying and mining operations.
- (3) The composition of gangue or substances associated with ore should also be carefully studied. Some substances are such that they will reduce the value of a rich iron ore while other substances are such that they will increase the value of lean iron ore.
- (4) The treatment and preparation to be given to iron ores to make them suitable for blast furnace should be simple and cheap. For instance, dense ores will require crushing or breaking up before use. This preliminary treatment becomes essential to increase the output.

### ***Important varieties of iron ores:***

Following are the important commercial varieties of iron ores which are commonly used in the manufacturing process:

- (1) Haematite
- (2) Limonite
- (3) Magnetite
- (4) Pyrite
- (5) Siderite.

(1) *Haematite* :

It is red oxide of iron. Its chemical composition is  $\text{Fe}_2\text{O}_3$ . It is a rich iron ore and it contains about 65 to 70 per cent of iron, when it is in a pure state. Its specific gravity varies from 4.50 to 5.30. Its colour is iron black or steel grey. This ore is available in India at Mysore and Madhya Pradesh. The other countries where this ore is available are England, U.S.A., Germany and France.

(2) *Limonite* :

It is brown haematite. Its chemical composition is  $2\text{Fe}_2\text{O}_3, 3\text{H}_2\text{O}$ . It contains about 60 per cent of iron. Its specific gravity varies from 3.60 to 4.00. Its colour is brown, yellowish brown or yellow. This ore is available in India at Jamshedpur. The other countries where this ore is available are England and Spain.

(3) *Magnetite* :

It is black oxide of iron. Its chemical composition is  $\text{Fe}_3\text{O}_4$ . It is the richest iron ore and it contains about 70 to 73 per cent of iron, when it is in a pure state. Its specific gravity varies from 4.90 to 5.20. Its colour is black. This ore is available in India at Madras. But it is not made use of, as coal fields are not located nearby. The other countries where this ore is available are Sweden, Russia, Canada, Ireland, Norway and U.S.A.

(4) *Pyrite* :

It is sulphide of iron. Its chemical composition is  $\text{FeS}_2$ . Its maximum iron content is about 45 to 47 per cent. Its specific gravity varies from 4.80 to 5.10. Its colour is bronze yellow or pale brass yellow. This ore is quite widely spread in almost all parts of the world. But the higher percentage

of sulphur in this ore makes the resulting iron brittle. Hence, it is not adopted in the manufacture of iron.

(5) *Siderite*:

It is carbonate of iron. Its chemical composition is  $\text{FeCO}_3$ . It is also known as *spathic iron ore*. Its maximum iron content is about 40 per cent. Its specific gravity varies from 3.70 to 3.90. Its colour is pale yellow, brownish red or brownish black. This ore is available in India at Raniganj, Bengal. The other countries where this ore is available are England and Russia.

**Pig-iron:**

The crude impure iron which is extracted from iron ores is known as *pig-iron* and it forms the basic material for the manufacture of cast-iron, wrought-iron and steel. We will, therefore, study at this stage the manufacture and classification of pig-iron.

**Manufacture of pig-iron:**

Following *three* distinct operations are involved in the manufacturing process of pig-iron:

- (1) Dressing
- (2) Calcination and roasting
- (3) Smelting.

(1) *Dressing*:

Iron ores as obtained from mines are crushed into pieces of size of 25 mm diameter. This is achieved in rock crushers of ordinary type. Crushing of ores helps in *two* ways:

- (i) Ore particles of uniform size are obtained.
- (ii) Reducing gases penetrate the ores in a better way.

If ores contain clay, loam and other earthy matter, they are washed in a stream to remove such impurities. Perforated trays may be kept in water to remove pebbles and sand. To work in dry condition, magnetic separators are used to remove the impurities contained in iron ores

## (2) *Calcination and roasting:*

After the iron ores are dressed, they are calcined and roasted. Calcination consists in heating ores in presence of air so that they are oxidised. Water and carbon dioxide are removed from ores by calcination. Roasting consists of making the ores hot and very dry. It is adopted to dissipate the volatile parts, especially sulphur, by heat. Hence roasting will not be necessary, if ore is an oxide.

## (3) *Smelting:*

Melting so as to separate metal from ore is known as *smelting*. It is carried out in a special type of furnace, known as *blast furnace*. It is in the form of a vertical steel cylinder. The outer shell of furnace is of steel plate about 30 mm to 40 mm thick and its inside surface is covered with a lining of fire-bricks. Its diameter is about 6 m to 8 m and its height is about 30 m.

### *Essential parts and equipment of a blast furnace:*

Fig. 9-1 shows the details of a typical blast furnace. Following are its essential parts:

#### (i) Throat:

This is the feeding zone or mouth of blast furnace. It is located near top portion of furnace.

#### (ii) Stack:

This is also known as *inwall* and it extends from throat to cylinder. Its height is about 18 m or so. The dimensions of the stack are to be carefully determined. The angle of inclination varies from  $85^\circ$  to  $87^\circ$ . The height of stack should be such that iron ores are sufficiently heated, prepared and reduced before they reach the next zone.

#### (iii) Cylinder:

This is also known as *barrel*. Its sides are parallel. It connects stack and bosh. The ratio of total height of furnace to diameter of cylinder should be about 4.00 to 4.50. It is omitted in the design of some blast furnace.

## (iv) Bosh:

This is the burning zone of furnace. It is the hottest part of the furnace. It is located between the cylinder and hearth. It has an inward slope and it varies from  $76^\circ$  to  $80^\circ$ . The height of bosh is about 15 to 20 per cent of the total height of blast furnace.

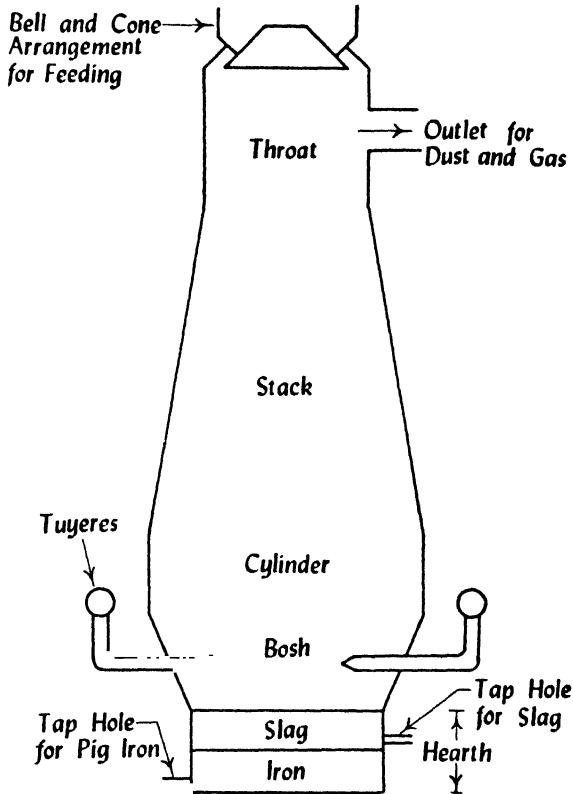

Blast furnace

FIG. 9-1

## (v) Hearth:

This is also known as *crucible* and it is the lowest part of the furnace. Slag and molted iron collect in this portion. Its height is about 2 m to 3 m.

## (vi) Tuyeres:

A tuyere is a nozzle for a blast of air. They are located in the bosh portion of furnace. The diameter of tuyeres will

depend on the desired blast pressure and the quantity of air required in unit time. The actual number of tuyeres will be decided from the diameter of hearth of furnace.

(vii) Feeding arrangement:

The materials are fed from the top of furnace. Receiving hoppers with double cup and cone arrangement are provided to receive the raw materials. A pair of inclined tracks is provided and the raw materials are hauled by skip cars upto the receiving hoppers.

(viii) Additional equipment:

In addition to the above parts, a blast furnace is provided with the following additional equipment:

- (a) Hot blast stoves about 3 to 5 are attached to a blast furnace. They are provided to utilise the heat of blast furnace gas. They are in the form of steel cylinders. Their inside surface is covered with a refractory material. They are filled with fire-bricks which are arranged in a criss-cross manner to allow circulation of gas or air. The heat of gas is stored in fire-bricks and it is then supplied to air which is used as a blast for furnace.
- (b) There should be sufficient number of storage units to store the raw materials. These units should be well fitted in the general layout of the blast furnace.
- (c) Blowers of desired capacity are installed to supply air to the tuyeres. These are required to blow air at constant volume and the blast pressure is regulated by the size of tuyeres.
- (d) Devices are provided to clean blast furnace gas before it is put to some useful purpose. The surplus blast furnace gas can be utilised for various purposes such as firing open hearth and reheating furnaces, raising temperature of water, etc.

*Working of a blast furnace:*

- (i) The raw materials consist of iron ores, fluxing material and fuel. Fluxing material is the substance which can be easily fused. It mixes with

the impurities present in iron ores and forms fusible slag. Commonly used fluxing material is limestone which is also crushed to the same size as iron ore. For fuel, coke is widely used in most of the plants. Charcoal may also be used as fuel.

- (ii) A mixture of raw materials is prepared in the required proportions and it is elevated upto the top of furnace. This mixture is then allowed to descend through throat portion of the furnace.
- (iii) A blast of hot air is forced through blast pipe and tuyeres. Blast pipe runs round the surface. A high temperature of about 1300°C to 1500°C is obtained in the lower portion of furnace.
- (iv) Following reactions occur between carbon or carbon monoxide and iron ore to form iron:

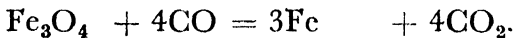
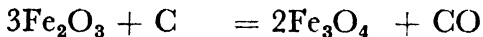

- (v) Pig-iron which is thus formed collects in the hearth furnace. Slag which is formed by reactions between fluxing material and impurities in ore also collects in the hearth of furnace and as it is light in weight, it floats on pig-iron.
- (vi) The hot gases and dust escape through outlet which is provided in the throat portion of furnace. Slag is removed, usually after two hours, through an outlet which is provided at higher level. Melted iron is taken out, usually after four hours, through tap hole provided at suitable height. Molten iron is led into sand moulds where it becomes solid. It is then taken out in short lengths from these moulds. These are known as *sows* and *pigs* as they exhibit curved surfaces, when inverted.
- (vii) Pig-iron, as obtained above, contains about 93 to 95 per cent of iron, about 4 to 5 per cent of carbon

and the remaining being sulphur, silicon, manganese, phosphorus, etc. Slag, as obtained above, contains about 45 per cent of lime, about 35 per cent of silica, about 12 per cent of alumina and the remaining being other impurities such as magnesia, calcium sulphate, manganese oxide, etc. This slag may be thrown away or it can be used for various purposes as follows:

- (a) in cement concrete as coarse aggregate,
- (b) in making roads as road metal,
- (c) in railways as ballast,
- (d) in the manufacture of blast furnace cement, etc.

### Types of pig-iron:

Following are the varieties of pig-iron:

- (1) Bessemer pig
- (2) Grey pig
- (3) White pig
- (4) Mottled pig.

#### (1) *Bessemer pig*:

This is obtained from haematite ores. It should be free from copper, phosphorus and sulphur. The presence of silicon and manganese in small amounts improves the quality of pig. This pig is used in the manufacture of steel by Bessemer or acid open-hearth process.

#### (2) *Grey pig*:

This is also known as *foundry pig*. It is produced when the furnace is provided sufficiently with fuel and the raw materials are burnt at a very high temperature. Grey colour is exhibited by the fracture of this pig. Depending upon the amount of carbon, it is classified in various grades. This is a soft variety of pig and it is mainly used for cast-iron castings.

#### (3) *White pig*:

This is also known as *forge pig*. It is produced when the furnace is not provided with sufficient fuel or when the

raw materials are burnt at low temperature or when ore or fuel contains a higher percentage of sulphur. It is an inferior variety of grey carbon and it contains more percentage of combined carbon. It is, therefore, unfit for superior castings. It is hard and strong. It can be easily melted. It is used in the manufacture of wrought-iron.

#### **(4) *Mottled pig:***

This variety of pig lies somewhere between grey pig and white pig. Fracture of this pig is mottled. It is stronger and it contains a large proportion of combined carbon. It is unfit for light and ornamental castings. It is used for heavy foundry castings.

#### **Other methods of pig-iron manufacture:**

The manufacturing process of pig-iron, as discussed above, is the most standard one. But in modern age, attempts are made to modify it or to adopt new methods of manufacturing pig-iron mainly for *two* reasons:

- (1) The height of modern blast furnace has increased. It requires more capital and labour for its working.
- (2) To most of the nations which are producing pig-iron, coke, which is used as fuel, is becoming either short or inaccessible.

Following are the other alternative methods of pig-iron manufacture:

- (1) Electric reduction furnace
- (2) Low shaft blast furnace
- (3) Sponge iron process.

It is not intended here to give a detailed description of each alternative method. Some important features of each method will now be briefly described.

#### **(1) *Electric reduction furnace:***

This type of furnace can be adopted at places where electric power can be economically and cheaply generated. There are various forms of this furnace. In one form, the hearth has a diameter about three to four times of stack

diameter. The furnace is heated by electrodes passing through the roof.

Following are the *advantages* of this furnace:

- (i) As electric power is used, coke is required as reducing agent only. It, therefore, results in considerable reduction, about 60% or so, in its consumption.
- (ii) External supply of air is not necessary in this furnace.
- (iii) It is flexible in operation and can be economically operated for different outputs.
- (iv) It is possible to employ raw materials of low grade in this furnace.
- (v) It is possible to manufacture iron with low sulphur content by this furnace.
- (vi) Less quantity of fluxing material is required.
- (vii) Less quantity of slag is formed.
- (viii) The gas produced in this furnace possesses higher calorific value. Its quantity is only about 15% or so than that produced in an ordinary blast furnace.

The only drawback of this furnace is that its initial and maintenance costs are somewhat more. Its adoption, however, largely depends on the relative costs of coke and electric power.

## (2) *Low shaft blast furnace:*

In this furnace, the blast is made rich in oxygen. It, therefore, depends on the availability of commercial oxygen at cheap rate. In blast of ordinary furnace, nearly 60% is nitrogen which does not take any active part in chemical reactions. It only acts as a carrier of heat. Hence if blast is enriched with oxygen, reduction of iron ores can be carried out in a shorter time and it will also result in reduction of stack height.

Following are the *advantages* of this furnace:

- (i) The gas produced possesses high calorific value.
- (ii) This furnace consumes fine ores.
- (iii) This furnace consumes or depends on oxygen which can be made available from natural air.

- (iv) This furnace permits the use of inferior fuels such as lignite, brown coals, etc.

The output from this furnace is comparatively low and it will require an assured supply of large quantity of bulk oxygen.

**(3) *Sponge iron process:***

This process consists of getting iron directly from the ore. The ore is reduced at a temperature, which is below its melting point. The product thus obtained is called the *sponge iron* and it is practically a porous mass of reduced iron with some amount of slag in it. The iron ore for this process should be coarse and it should not disintegrate at high temperature. The initial and maintenance costs of this process are comparatively high. This process is quite extensively employed in Japan and Germany.

**Some terms:**

To describe the nature and property of metals, various terms are used. Some of these terms are defined below so as to bring out their meaning.

**(1) *Brittle material:***

A material which easily breaks into pieces or which can be easily reduced to powder form is known as a *brittle material*, e.g., glass.

**(2) *Ductile material:***

A material which can be drawn into fine wires is known as a *ductile material*, e.g., silver and copper.

**(3) *Hard material:***

A material which cannot be cut by a sharp tool is known as a *hard material*, e.g., diamond.

**(4) *Malleable material:***

A material which can be beaten into thin sheets or leaves is known as a *malleable material*, e.g., gold.

**(5) Soft material:**

A material which can be easily cut by a sharp weapon is known as a *soft material*, e.g., lead.

**(6) Tough material:**

A material which does not easily break under a hammer is known as a *tough material*, e.g., basalt.

**Cast-iron:**

Cast-iron is manufactured by remelting pig-iron with coke and limestone. This remelting is done in a furnace known as *cupola furnace*. It is more or less same as blast furnace. But it is smaller in size. Its shape is cylindrical with diameter of about 1 m and height of about 5 m. Fig. 9-2 shows a typical cupola furnace.

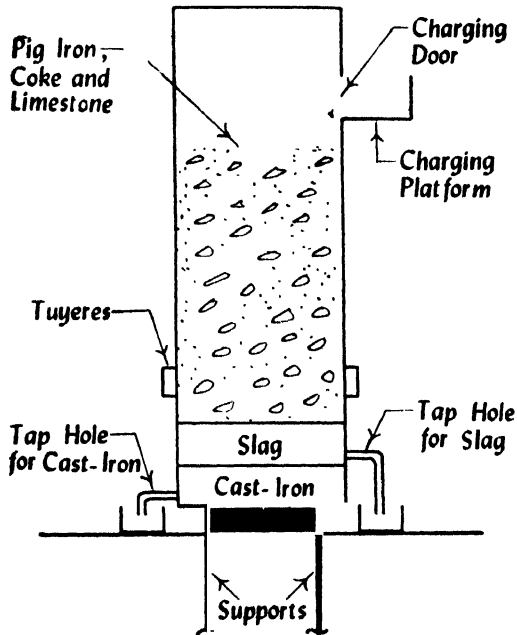

Cupola furnace

FIG. 9-2

Working of cupola furnace is also similar to that of blast furnace. The raw materials are fed from top. Cupola furnace is worked intermittently and it is open at top. After

the raw materials are placed, the furnace is fired and blast of air is forced through tuyeres. Blast of air is cold as the impurities in pig-iron are removed by oxidation. The impurities of pig-iron are removed to some extent and comparatively pure iron is taken out in the molten stage from the bottom of furnace. Slag is also removed from top of cast-iron at regular intervals. Molten cast-iron is led into moulds of required shapes to form what are known as *cast-iron castings*.

### ***Composition of cast-iron:***

Cast-iron contains about 2 to 4 per cent of carbon. In addition, it contains various impurities such as manganese, phosphorus, silicon and sulphur.

Manganese makes cast-iron brittle and hard. Its amount should, therefore, be kept below 0.75 per cent or so.

Phosphorus increases fluidity of cast-iron. It also makes cast-iron brittle and when its amount is more than 0.30 per cent, the resulting cast-iron is lacking in toughness and workability. Its percentage is sometimes kept as about 1 to 1.5 to get very thin castings.

Silicon combines with part of iron and forms a solid solution. It also removes combined carbon from graphite form. If its amount is less than 2.50 per cent, it decreases shrinkage and ensures softer and better castings.

Sulphur makes cast-iron brittle and hard. It also does not allow smooth cooling in sand moulds. Its presence causes rapid solidification of cast-iron and it ultimately results in blow-holes and sand-holes. Sulphur content should be kept below 0.10 per cent.

### ***Types of cast-iron:***

Following are the varieties of cast-iron:

- (1) Grey cast-iron
- (2) White cast-iron
- (3) Mottled cast-iron
- (4) Chilled cast-iron
- (5) Malleable cast-iron
- (6) Toughened cast-iron.

(1) *Grey cast-iron:*

This is prepared from grey pig. Its colour is grey with a coarse crystalline structure. It is soft and it melts readily. It is somewhat weak in strength. It is extensively used for making castings.

(2) *White cast-iron:*

Its colour is silvery white. It is hard and it melts with difficulty. It is not easily worked on machine. It cannot be used for delicate castings.

(3) *Mottled cast-iron:*

It is an intermediate variety between grey cast-iron and white cast-iron. Fracture of this variety is mottled. This variety is used for small castings.

(4) *Chilled cast-iron:*

Chilling consists of making some portion of cast-iron hard and other portion soft. This variety of cast-iron is hard to a certain depth from the exterior surface and it is indicated by white iron. The interior portion of the body of casting is soft and it is made up of grey iron. It is used to provide wearing surfaces to castings.

(5) *Malleable cast-iron:*

The composition of this variety of cast-iron is so adjusted that it becomes malleable. It is done by extracting a portion of carbon from cast-iron. It is used for railway equipment, automobiles, pipe fittings, agricultural implements, door fastenings, hinges, etc.

(6) *Toughened cast-iron:*

This variety of cast-iron is obtained by melting cast-iron with wrought-iron scrap. The proportion of wrought-iron scrap is about 1/4 to 1/7th of weight of cast-iron.

***Properties of cast-iron:***

Following are the properties of cast-iron:

- (1) If placed in salt water, it becomes soft.
- (2) It can be hardened by heating and sudden cooling. But it cannot be tempered.
- (3) It cannot be magnetised.

- (4) It does not rust easily.
- (5) It is fusible.
- (6) It is hard. But it is brittle also.
- (7) It is not ductile and hence it cannot be adopted to absorb shocks and impacts.
- (8) Its melting temperature is about  $1250^{\circ}\text{C}$ .
- (9) It shrinks on cooling. This fact is to be considered while making patterns or moulds for foundry work.
- (10) Its structure is granular and crystalline with whitish or greyish tinge.
- (11) It is weak in tension and strong in compression. Tensile and compressive strengths of cast-iron of average quality are respectively  $1500 \text{ kg/cm}^2$  and  $6000 \text{ kg/cm}^2$ .
- (12) Two pieces of cast-iron cannot be connected by the process of riveting or welding. They are to be connected by nuts and bolts which are fixed to flanges.

### ***Uses of cast-iron:***

Following are the important uses of cast-iron:

- (1) for making cisterns, water pipes, gas pipes and sewers, manhole covers and sanitary fittings,
- (2) for making ornamental castings such as brackets, gates, lamp posts, etc.,
- (3) for making parts of machinery which are not subject to heavy shocks,
- (4) for manufacturing compression members,
- (5) for preparing rail chairs, carriage wheels, etc.

### **Castings:**

For making an ordinary sand casting, the following procedure is generally adopted:

- (1) A pattern resembling the product to be casted is prepared. It is generally made from hard wood. Its inside surface is painted or waxed to give a smooth surface to the finished product. If pattern

is to be used several times, it may even be made of aluminium, brass or cast-iron. The dimensions of pattern are kept slightly more, about 10 per cent in each direction, to allow for shrinkage.

- (2) The pattern is generally divided into *two* portions — upper portion and lower portion. Each portion is placed in a rectangular frame made of wood or metal. This frame is known as *flask*.
- (3) The space between the flask and pattern is filled with green sand or loam and it is packed with wet moulding sand.
- (4) Vertical holes are made in the sand to serve as vent pipes.
- (5) When the sand has sufficiently dried, the pattern is carefully removed. The mould is thus prepared. It is cleaned and repaired to receive molten metal.
- (6) The two portions of mould are placed one above the other and the melted metal is poured in the mould.
- (7) After the metal has cooled down, the casting is taken out and the irregularities formed on the casting are carefully rubbed out or chipped off.

### ***Types of casting:***

Following are the various types of castings:

- (1) Centrifugal casting
- (2) Chilled casting
- (3) Die casting
- (4) Hollow casting
- (5) Sand casting
- (6) Vertical sand casting.

#### ***(1) Centrifugal casting:***

In this type of casting, molten metal is poured into moulds which are kept rotating. The quantity of metal should be carefully determined and accurately controlled. The moulds are cylindrical and made of metal. The molten metal is spread uniformly by centrifugal force and it is held till it becomes solid. This method is generally used to prepare

pipes and it is found that these castings are stronger and compact than ordinary castings.

(2) *Chilled casting:*

In this types of casting, outer surface is made hard by sudden cooling or chilling and the inner surface remains comparatively soft. The mould is either made of metal or is lined with metal. The hot molten metal is suddenly cooled or chilled as it comes into contact with metallic surface of the mould. The outer surface thus becomes suddenly hard and inner surface becomes soft and tough due to pressure of contraction on the molten metal. This type of casting is adopted to produce wearing surface as in case of tyres and axle holes of railway carriage wheels, etc.

(3) *Die casting:*

In this type of casting, molten metal is poured into metal moulds under pressure. These castings are cheap, smooth and compact. They require no finishing treatment except the removal of surplus metal.

(4) *Hollow casting:*

In this type of casting, the mould is made as usual and a solid core is suspended in the middle of mould to form cavity. The thickness of casting is represented by the space between the core and mould. The metal is poured into this annular space and when it has cooled down, the mould is removed and the core is withdrawn. This casting is used for preparing hollow columns, pipes, piles, etc.

(5) *Sand casting:*

This is the ordinary type of casting and its procedure is described above.

(6) *Vertical sand casting:*

In this type of casting, sand mould and solid core are held in a vertical position. This method of casting is used to prepare cast-iron pipes for carrying water under pressure.

***Characteristics of a good casting:***

A good casting should possess the following qualities or characteristics:

- (1) Its edges and corners should be sharp, perfect and clean.
- (2) Its fresh fracture should exhibit fine grained texture with bluish grey colour.
- (3) It should be free from air bubbles, cracks, etc.
- (4) It should be soft enough for drilling or chiselling.
- (5) It should be uniform in shape and it should be consistent with the requirements of the design.
- (6) Its outer surface should be smooth.

### ***Defects in casting:***

Sand castings are commonly adopted and if proper precautions are not taken during the process of sand casting, there are chances for the developments of the following defects:

(1) *Cold short:*

This defect is formed at the junction where two streams of molten metal meet. If these streams do not unite properly, cold short is formed at the junction point.

(2) *Drawing:*

In this type of defect, the metal becomes solid before the mould is completely filled up. It may develop either due to insufficient fluid state of metal or due to insufficient passage for the entry of metal into the mould.

(3) *Holes:*

If vent holes are insufficient, air and gases become entrapped and it ultimately results in porous casting with holes.

(4) *Honeycombing:*

The fusing of surface sand causes this defect in the casting.

(5) *Lifts and shifts:*

These are the external defects of casting and they are usually due to misplacement of core.

(6) *Scabbing:*

In this type of defect, scales are seen on the casting. It occurs when sand is very heavy and sticks to casting.

(7) *Swelling:*

When moulds are improperly rammed, swelling of casting takes place.

**Wrought-iron:**

***Manufacture of wrought-iron:***

Wrought-iron is almost pure iron and it hardly contains carbon more than 0.15 per cent or so. But the process of its manufacture is laborious and tedious. Following are the *four* distinct operations involved in its manufacture:

- (1) Refining
- (2) Puddling
- (3) Shingling
- (4) Rolling.

(1) *Refining:*

Pig-iron is melted and a strong current of air is directed over it. It is being well agitated or stirred when the current of air is passing over it. It is thus thoroughly oxidised. It is then cast into moulds. It is cooled suddenly so as to make it brittle. This is known as *refined pig-iron*.

(2) *Puddling:*

Conversion of pig-iron into wrought-iron by stirring in a molten state is known as *puddling*. It is carried out in a reverberatory furnace as shown in fig. 9-3. In this type of furnace, the metal does not come into contact with the fuel and flame from the fire is reverted or sent back on the metal in the hearth.

A reverberatory furnace is of rectangular shape. It is built with refractory materials such as fire-bricks. The combustion chamber and chimney are situated on opposite ends as shown in fig. 9-3. Grating is provided in combustion chamber to collect ash in ash pit. Next to combustion chamber is the hearth portion with shallow depth. Hearth lining consists of molten slag or rich iron ore. It is supported on steel plates which in turn are supported on dwarf brick

walls. Water jackets are provided for circulation of water to cool the furnace. Various doors or openings for fuel feeding, working and slag removal are provided. The roof is given a peculiar shape so that flames of gas produced are concentrated on hearth.

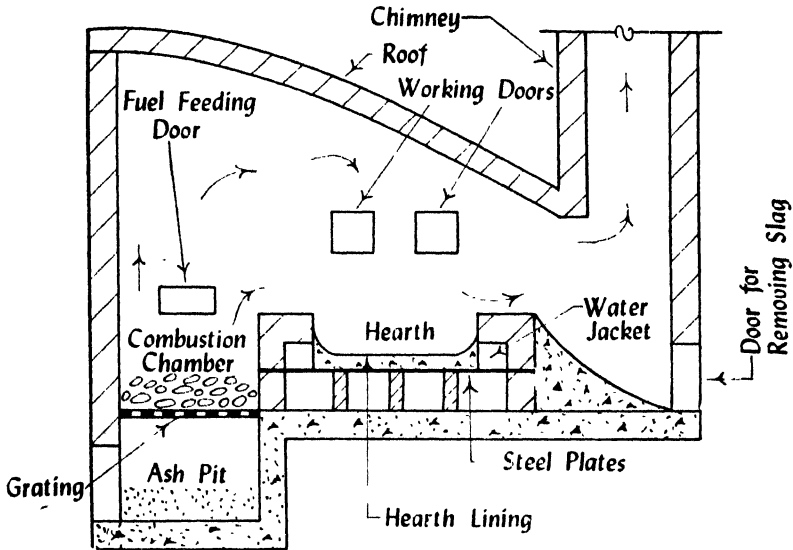

Reverberatory furnace

FIG. 9-3

The refined pig-iron is broken into lumps and it is melted in hearth of reverberatory furnace. The hearth lining acts as an oxidising agent and in addition, oxidising substances such as haematite ore, oxide of iron, etc. are added to the refined pig-iron. It is subjected to intense heat and a strong current of air. It is kept well stirred by long bars through working doors.

During the process of puddling, most of the carbon content and other impurities of pig-iron are oxidised. Slag formed is removed through slag removal door. The purified iron becomes thick and it assumes the form of white spongy iron balls. These are known as *puddle balls* and weight of each ball is about 50 kg to 70 kg.

### (3) *Shingling*:

By this operation, the slag contained in puddle balls is removed. It may be achieved by forging the balls under

a power hammer or by passing the balls through squeezing machine. In case of a power hammer, the balls are placed on an anvil and they are forged by a falling hammer. A squeezing machine consists of two cylinders which are placed one inside the other. The smaller cylinder has corrugations on its outer surface and the larger cylinder has corrugations on its inner surface. The balls are placed in between the cylinders and then the inner cylinder is rotated.

Shingling also helps in binding or welding the different particles of puddle balls. The material obtained at the end of shingling is known as *bloom* and it is still in red hot condition.

(4) *Rolling:*

The bloom is passed through grooved rollers and flat bars of size about 4 m × 10 cm × 25 mm are obtained. These bars indicate wrought-iron of poor quality. To improve the quality of wrought-iron, these bars are tied together by wires and they are heated and rolled again. This process may be repeated several times to get wrought-iron of desired quality.

***Aston's process:***

This process of manufacturing wrought-iron was developed by James Aston of America in 1925. This process is wholly mechanical and by this process, wrought-iron can be manufactured quickly and economically. It is carried out as follows:

- (1) Molten steel from bessemer converter is poured into cooler liquid slag. Temperature of molten steel is about 1500°C and that of liquid slag is about 1200°C.
- (2) Molten steel contains large amounts of dissolved gases. These gases are liberated when it strikes the slag.
- (3) Molten steel freezes and it results in a spongy mass having a temperature of about 1370°C.
- (4) This spongy mass is then given the treatment of shingling and rolling as described above.

***Properties of wrought-iron:***

Following are the properties of wrought-iron:

- (1) It becomes soft at white heat and it can be easily forged and welded.
- (2) It fuses with difficulty. It cannot, therefore, be adopted for making castings.
- (3) It is ductile, malleable and tough.
- (4) It is moderately elastic.
- (5) It resists corrosion in a better way.
- (6) Its fresh fracture shows clear bluish colour with a high silky luster and fibrous appearance.
- (7) Its melting point is about  $1500^{\circ}\text{C}$ .
- (8) Its specific gravity is about 7.8.
- (9) Its ultimate compressive strength is about  $2000\text{ kg/cm}^2$ .
- (10) Its ultimate tensile strength is about  $4000\text{ kg/cm}^2$ .

***Defects in wrought-iron:***

Wrought-iron which has become defective may either be *cold short* or *red short*.

Cold short wrought-iron is very brittle when it is cold. It cracks, if bent. It may, however, be worked at high temperature. This defect occurs when phosphorus is present in excess quantity.

Red short wrought-iron possesses sufficient tenacity when cold. But it cracks when bent or finished at a red heat. It is, therefore, useless for welding purpose. This defect occurs when sulphur is present in excess quantity.

***Uses of wrought-iron:***

Wrought-iron is replaced at present to a very great extent by mild steel. It is, therefore, produced to a very small extent at present. It is used where a tough material is required. Wrought-iron, at present, is used for rivets, chains, ornamental iron work, railway couplings, water and steam pipes, raw material for manufacturing steel, bolts and nuts, horse shoe bars, handrails, straps for timber roof trusses, etc.

**QUESTIONS**

1. Define an ore and mention the points to be examined while selecting the site for mines.
2. Discuss important varieties of iron ores.
3. Describe manufacturing process of pig-iron by blast furnace.
4. Draw a neat sketch of a blast furnace and mention its essential parts and equipments.
5. Explain the working of a blast furnace.
6. Explain different types of pig-iron.
7. Write short notes on:
  - (1) Sponge iron process
  - (2) Composition of cast-iron
  - (3) Chilled casting
  - (4) Defects in sand castings
  - (5) Aston's process
  - (6) Defects in wrought-iron
  - (7) Centrifugal casting
  - (8) Puddling.
8. How is pig-iron manufactured by electric reduction furnace and low shaft blast furnace? What are the advantages of these methods?
9. Define the following terms:  
Brittle material; Ductile material; Hard material;  
Malleable material; Soft material; Tough material.
10. Draw a neat sketch of a cupola furnace and explain its working.
11. Discuss various types of cast-iron.
12. Enumerate properties of cast-iron.
13. State important uses of cast-iron.
14. How is sand casting made?
15. Describe various types of castings.
16. What are the characteristics of a good casting?
17. How is wrought-iron manufactured?
18. Draw a neat sketch of a reverberatory furnace and explain its working.

19. Enumerate the properties and uses of wrought-iron.
20. Give sketches of the following:
  - (1) Blast furnace
  - (2) Cupola furnace
  - (3) Reverberatory furnace.
21. Differentiate between the following:
  - (1) Ferrous metals and non-ferrous metals
  - (2) Haematite and limonite
  - (3) Grey pig and white pig
  - (4) Malleable cast-iron and toughened cast-iron
  - (5) Die casting and sand casting
  - (6) Calcination and roasting
  - (7) Brittle metal and ductile metal
  - (8) Shingling and rolling
  - (9) Stack and bosh
  - (10) Soft material and tough material
  - (11) Grey cast-iron and white cast-iron
  - (12) Centrifugal casting and chilled casting
  - (13) Cold short wrought-iron and red short wrought-iron.
22. Give reasons for the following:
  - (1) Sulphur content in cast-iron should be kept below 0.10 per cent.
  - (2) Water jackets are provided in reverberatory furnace.
  - (3) Red short wrought-iron is useless for welding purpose.
  - (4) Pyrite is not adopted in the manufacture of iron.
  - (5) Roasting is not necessary, if ore is oxide.
  - (6) Hot blast stoves about 3 to 5 are attached to a blast furnace.
  - (7) White pig is unfit for superior castings.
  - (8) The dimensions of pattern to be used for casting are kept slightly more in each direction.
  - (9) The roof of a reverberatory furnace is given a peculiar shape.
  - (10) Wrought-iron cannot be adopted for making castings.
  - (11) The composition of gangue or substances associated with ore should be carefully studied.
  - (12) Blowers of desired capacity are installed in a blast furnace.

# Chapter 10

## STEEL

### General:

As far as carbon content is concerned, steel forms an intermediate stage between cast-iron and wrought-iron. Cast-iron contains carbon from 2 to 4 per cent. In wrought-iron, the carbon content does not exceed 0.15 per cent. In steel, carbon content varies from anything below 0.25 per cent to 1.50 per cent maximum.

Cast-iron can take up only compressive stresses and its use is limited to compression members only. Wrought-iron is of a fibrous nature and it is suitable to resist tensile stresses. Steel is suitable for all constructional purposes in general and hence, it has practically replaced cast-iron and wrought-iron in the present day practice of building construction. It is equally strong in compression as well as in tension.

The final battle between cast-iron, wrought-iron and steel was fought on the field of construction of skyscrapers. The columns of early skeleton of skyscrapers were of cast-iron and the beams were of wrought-iron. Bessemer invented his converter in 1855 and it came into use from 1880 or so. The introduction of the open-hearth process brought the final victory to steel because it produced a better quality steel that could take up higher working stresses.

### Manufacture of steel:

Steel is manufactured by the following processes:

- (1) Bessemer process
- (2) Cementation process
- (3) Crucible steel process
- (4) Duplex process
- (5) Electric process
- (6) L.D. process
- (7) Open-hearth process.

Each process will now be briefly described.

(1) *Bessemer process:*

Depending upon the nature of lining material of converter, this process may be acidic or basic. In acidic process, the lining material is acidic in nature such as clay, quartz, etc. It is adopted when iron ores are free from or when they contain very small amount of sulphur and phosphorus. In basic process, the lining material is basic in nature such as lime, magnesia, etc. It is adopted for pig-iron containing impurities of any type. Basic process is commonly adopted.

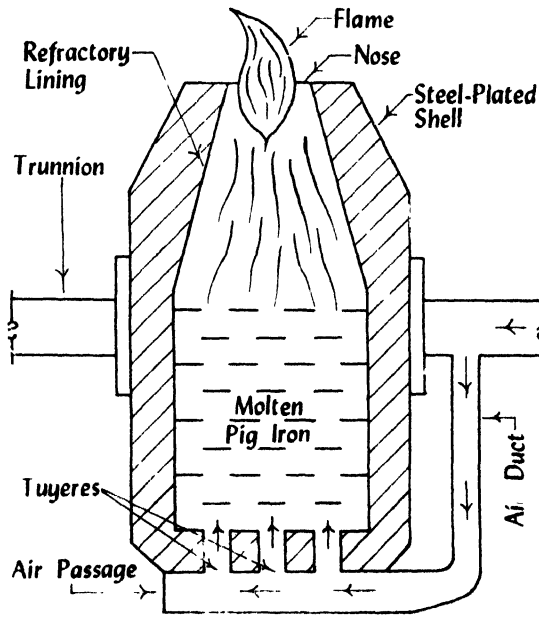

Bessemer converter

FIG. 10-1

Bessemer converter is wide at bottom and narrow at top as shown in fig. 10-1. It is mounted on two horizontal trunnions so that it can be tilted or rotated at suitable angle. Tuyeres are provided at the bottom to allow passage of air from air duct to pig-iron. Working of converter is as follows:

- (i) Converter is tilted and it is charged with molten pig-iron from cupola furnace or sometimes even directly from blast furnace.

- (ii) Converter is brought in an upright position and a blast of hot air is forced through tuyeres.
- (iii) Air passes through the molten pig-iron. It oxidises impurities of pig-iron and a brilliant reddish-yellow flame is seen at the nose of converter.
- (iv) The flame is accompanied by a loud roaring sound and within 10 to 15 minutes or so, all the impurities of pig-iron are oxidised. The order of oxidation of various impurities is silicon, carbon, manganese, sulphur and phosphorus.
- (v) When the intensity of flame has considerably reduced, blast is shut off and required amount of suitable material such as ferro-manganese, spiegel-eisen, etc. is added to make steel of desired quality.
- (vi) Blast of air is started for a few minutes. Converter is then tilted in discharge position and molten metal is carried into ladles or containers.
- (vii) Molten metal is poured into large rectangular moulds for solidification. Such solidified mass is known as *ingot*. These ingots are then further treated to form steel of commercial pattern.

## (2) ***Cementation process:***

This process was formerly used to manufacture steel. It is costly and it is now, therefore, practically not adopted. It consists in converting pig-iron to almost pure wrought-iron and then preparing steel by adjusting carbon content. This process is carried out as follows:

- (i) Bars of pure wrought-iron are taken and they are placed between the layers of powdered charcoal. Dome shaped furnace known as *cementation furnace* is generally used for this purpose.
- (ii) The furnace is heated and the bars are subjected to an intense heat for a period of 5 to 15 days as per quality of steel required.
- (iii) Wrought-iron combines with carbon and steel of desired composition is formed. This steel is covered with blisters or thin bubbles and it is therefore, known as *blister steel*. Its structure is

not homogeneous and it is full of cavities and fissures. Blister steel cannot be used for making edge tools. It can only be used for machine parts and facing hammers.

**(3) Crucible steel process:**

This process is adopted to produce small quantity of high carbon steel. In this process, fragments of blister steel or short bars of wrought-iron are taken and they are mixed with charcoal. They are then placed in fire clay crucibles and heated. The molten iron is poured into suitable moulds. Steel produced by this process is known as *cast steel*. It is hard and uniform in quality. It is used for making surgical instruments, files, cutlery of superior quality, etc.

**(4) Duplex process:**

This process is a combination of the following *two* processes:

- (i) Acid Bessemer process
- (ii) Basic open-hearth process.

Following operations are, therefore, performed in preparing steel by Duplex process:

- (a) Molten pig-iron is given treatment in acid-lined Bessemer converter. Impurities such as silica, manganese and carbon are eliminated at this stage.
- (b) It is then treated in basic lined open-hearth. Impurities such as sulphur and phosphorus are eliminated at this stage.

It is thus seen that Duplex process is found out to take advantages of both the processes, namely, Bessemer process and open-hearth process. This process is economical and it results in considerable saving of time.

To improve the quality of steel further, Duplex process may be extended to Triplex process. Molten pig-iron, as obtained from basic lined open-hearth, is further treated in electric furnace to produce steel of high quality.

**(5) Electric process:**

In this process, electricity is used for heating and melting the metal. The other procedure is same as in case of Bessemer process or open-hearth process.

An electric furnace may either be rectangular or circular. It is made from steel plates. It is lined with basic refractory material. It is mounted on rollers so that it can be tilted as required. It is provided with electrodes. When electric current is switched on, electric arcs are formed between electrodes and surface of metal and with the intense heat of these arcs, metal is heated and melted. The capacity of electric furnace is about 10 to 15 tonnes and it is, therefore, not suitable for manufacturing steel on a large scale. It is, however, used to prepare special steel on a small scale.

Following are the *advantages* of this process:

- (i) Heat is quickly supplied and it is possible to have a wide range of possible temperatures.
- (ii) It presents a neat and clean operation.
- (iii) Quantity of slag formed is small.
- (iv) Temperature can be properly controlled.
- (v) There is absence of ash and smoke.

**(6) L.D. process:**

This process is a modification of Bessemer process. It is named as Linz—Donawitz process or L.D. process as it was first invented in Austria and adopted in *two* towns—Linz and Donawitz.

In this process, pure oxygen is used instead of air. In L.D. converter, a jet of pure oxygen is blown at extraordinary speed on molten metal. High temperature developed in the converter burns away impurities of metal and highly pure low carbon steel is prepared.

The process is economical in initial cost as well as in maintenance cost. It is partly adopted at Rourkela (Orissa state). Each L.D. converter is capable of producing about 40 tonnes of steel in only about 40 minutes or so.

Following are the *disadvantages* of this process:

- (i) An oxygen plant to prepare oxygen is required.
- (ii) It cannot treat pig-iron of all grades and varieties.
- (iii) It is not possible to control temperature precisely.

### (7) *Open-hearth process:*

This is also sometimes referred to as *Siemens-Martin process* as Siemens first invented this process and Martin made some improvements in the process. The open-hearth process may either be acidic or basic as in case of Bessemer process. Basic open-hearth process is more commonly adopted.

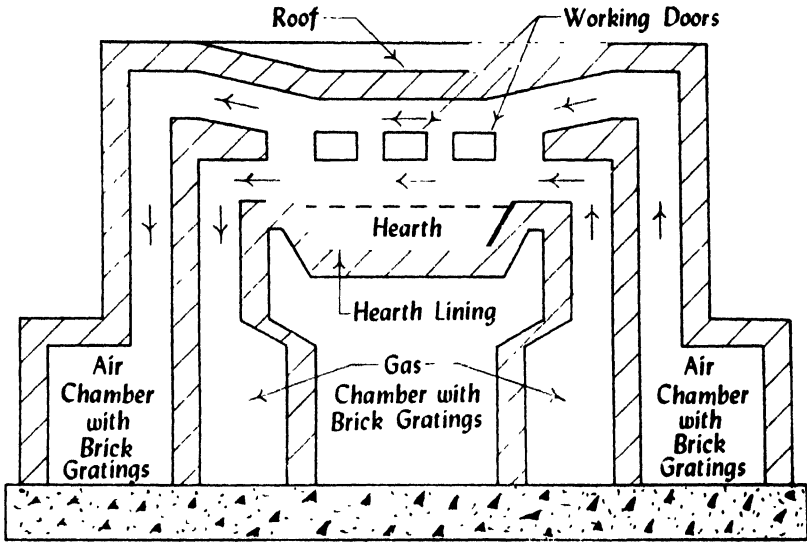

Open-hearth furnace

FIG. 10-2

This process is carried out in open-hearth furnace as shown in fig. 10-2. This furnace resembles the reverberatory furnace which is used in the manufacturing process of wrought-iron. Working of furnace is as follows:

- (i) Hearth is filled with molten pig-iron from cupola furnace or sometimes even directly from blast furnace.
- (ii) A mixture of preheated air and coal gas is allowed to pass over the hearth. This mixture catches fire and because of the peculiar shape of the roof, it attacks the molten metal. This produces intense heat and impurities of metal are oxidised.

- (iii) When impurities of metal are removed to the desired extent, suitable material such as ferro-manganese, spiegeleisen, etc. is added to make steel of required quality.
- (iv) Molten metal is then poured into moulds for forming ingots. These are then further treated to form steel of commercial pattern.

This process is extensively used in the manufacturing process of steel as it possesses the following *advantages*:

- (i) Basic slag obtained from open-hearth process contains phosphorus. This slag in powder form can, therefore, be used as good fertiliser.
- (ii) Great economy can be achieved by providing regenerative chambers on either side of the hearth as shown in fig. 10-2. These chambers make use of the waste heat of hot gases of combustion. The hot gases are allowed to pass through brick gratings of regenerative chamber before they escape through chimney. The directions of entering and leaving for air and gas are reversed at regular short intervals. The heated brick gratings pass on heat preserved by them to the entering air and gas.
- (iii) The operations involved in the process are simple.
- (iv) This process makes it possible to utilise a high percentage of scrap and this scrap is converted into new useful steel by this process.
- (v) Time required to remove impurities is short.
- (vi) Steel manufactured by this process is homogeneous in character.

### Uses of steel:

Depending upon the carbon content, steel is designated as *mild steel* or *medium carbon steel* or *high carbon steel*. Various uses of steel are governed by the amount of carbon contained in it.

Carbon content of mild steel is about 0.10 to 0.25 per cent. When carbon content is less than 0.10 per cent, it is known as *dead steel* or *very low carbon steel*.

Carbon contents of medium carbon steel is about 0.25 to 0.60 per cent.

High carbon steel is also known as *hard steel* and its carbon content varies from 0.60 to 1.10 per cent or so.

Table 10-1 shows the various uses of steel of each category.

**TABLE 10-1**  
**USES OF STEEL**

Name of steel	Carbon content	Uses
Mild steel	Upto 0.10%	Motor body, sheet metal, tin plate, etc.
Medium carbon steel	Upto 0.25%	Boiler plates, structural steel, etc.
	Upto 0.45%	Rails, tyres, etc.
	Upto 0.60%	Hammers, large stamping and pressing dies, etc.
High carbon steel or hard steel	Upto 0.75%	Sledge hammers, springs, stamping dies, etc.
	Upto 0.90%	Miner's drills, smith's tools, stone mason's tools, etc.
	Upto 1.00%	Chisels, hammers, saws, wood working tools, etc.
	Upto 1.10%	Axes, cutlery, drills, knives, picks, punches, etc.

### **Factors affecting physical properties of steel:**

The physical properties of steel such as ductility, elasticity, strength, etc. are greatly influenced by the following *three* factors:

- (1) Carbon content
- (2) Presence of impurities
- (3) Heat treatment processes.

#### **(1) Carbon content:**

Variations in carbon percentage produces steel of different grades. Carbon always assists in increasing the hardness and strength of steel. But at the same time, it decreases the ductility of steel. Mild steel having carbon content of about 0.10 to 0.25 per cent is widely used for structural work.

## (2) *Presence of impurities:*

Usual impurities in steel are silicon, sulphur, phosphorus and manganese.

If silicon content is less than 0.20 per cent, it has no appreciable effect on physical properties of steel. If silicon content is raised to about 0.30 to 0.40 per cent, elasticity and strength of steel are considerably increased without serious reduction in its ductility.

If sulphur content is between 0.02 to 0.10 per cent, it has no appreciable effect on ductility or strength of steel. It, however, decreases malleability and weldability of hot metal. Excess of sulphur decreases strength and ductility of steel.

Phosphorus produces detrimental effects on steel. It is desirable to keep its content below 0.12 per cent. It reduces shock resistance, ductility and strength of steel.

Manganese helps to improve the strength of mild steel. Its desirable content is between 0.30 to 1.00 per cent. When its content exceeds about 1.50 per cent or so, steel becomes very brittle and hence, it loses its structural value.

## (3) *Heat treatment processes:*

Effect of various heat treatment processes are discussed later on in this chapter.

## **Magnetic properties of steel:**

Steel is also widely used in electrical machinery, generators, transformers, etc. For making steel suitable for such use, its magnetic properties are given supreme importance and these properties are obtained by carefully adjusting its chemical composition. Following are the proportions of various elements in steel for making it to achieve better magnetic properties:

### (1) *Carbon:*

It is desirable to keep carbon content as low as possible and it should not exceed 0.10 per cent.

(2) ***Silicon:***

Presence of silicon results in considerable increase of electrical losses and hence, it is highly undesirable.

(3) ***Sulphur and phosphorus:***

If combined content of sulphur and phosphorus exceeds about 0.30 per cent, magnetic properties of steel are greatly affected.

(4) ***Manganese:***

If content of manganese exceeds about 0.30 per cent, it proves to be injurious to the magnetic properties of steel.

**Defects in steel:**

Following are the common defects in steel:

- (1) Cavities or blow-holes
- (2) Cold shortness
- (3) Red shortness
- (4) Segregation.

(1) ***Cavities or blow-holes:***

These are formed when gas is confined or imprisoned in molten mass of metal. Such confined gas produces bubbles or blow-holes on solidification of metal.

(2) ***Cold shortness:***

Steel, having this defect, cracks when being worked in cold state. This defect is due to presence of excess amount of phosphorus.

(3) ***Red shortness:***

Steel, having this defect, cracks when being worked in hot state. This defect is due to presence of excess amount of sulphur.

(4) ***Segregation:***

Some constituents of steel solidify at an early stage and they separate out from the main mass. This is known as *segregation* and it is prominent on the top surface of ingots or castings.

### Market forms of steel:

Following are the various forms in which steel is available in market:

- (1) Angle sections
- (2) Channel sections
- (3) Corrugated sheets
- (4) Expanded metal
- (5) Flat bars
- (6) I-sections
- (7) Plates
- (8) Ribbed-steel bars
- (9) Round bars
- (10) Square bars
- (11) T-sections.

#### (1) *Angle sections:*

Angle sections may be of equal legs or unequal legs as shown in fig. 10-3 and fig. 10-4 respectively. Equal angle

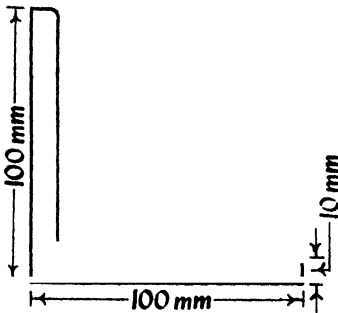

Equal angle section

FIG. 10-3

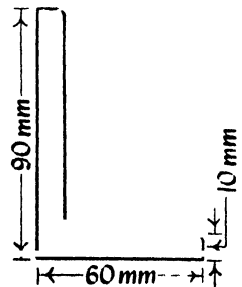

Unequal angle section

FIG. 10-4

sections are available in sizes varying from 20 mm × 20 mm × 3 mm to 200 mm × 200 mm × 25 mm. The corresponding weights per metre length are respectively 0.90 kg and 73.60 kg. Unequal angle sections are available in sizes varying from 30 mm × 20 mm × 3 mm to 200 mm × 150 mm × 18 mm. The corresponding weights per metre length are respectively 1.10 kg and 46.90 kg. Fig. 10-3 shows an equal angle section of size 100 mm × 100 mm × 10 mm

with weight per metre length as 14.90 kg. Fig. 10-4 shows an unequal angle section of size 90 mm  $\times$  60 mm  $\times$  10 mm with weight per metre length as 11.00 kg.

Angle sections are extensively used in structural steelwork especially in the construction of steel roof trusses and filler joist floors.

### (2) *Channel sections:*

Channel sections consist of a web with two equal flanges as shown in fig. 10-5. A channel section is designated by the height of web and width of flange. These sections are available in sizes varying from 100 mm  $\times$  45 mm to 400 mm  $\times$  100 mm. The corresponding weights per metre length are respectively 5.80 kg and 49.40 kg. Fig. 10-5 shows a channel section of size 300 mm  $\times$  100 mm with weight per metre length as 33.10 kg.

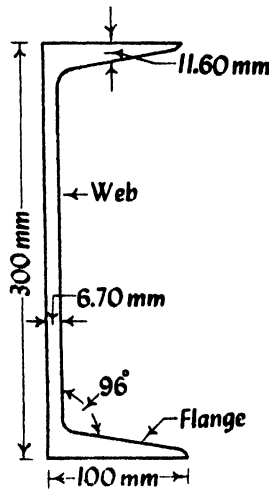

Channel section

FIG. 10-5

Channel sections are widely used as structural members of the steel framed structures.

### (3) *Corrugated sheets:*

These are formed by passing steel sheets through grooves. These grooves bend and press steel sheets and corrugations are formed on the sheets. These corrugated sheets are

usually galvanised and they are referred to as galvanised iron sheets or G.I. sheets. These sheets are widely used for roof covering.

**(4) Expanded metal:**

This form of steel is available in different shapes and sizes. Fig. 10-6 shows a plain expanded metal. It is prepared from sheets of mild steel which are machine cut and drawn out or expanded. A diamond mesh appearance is thus formed throughout the whole area of the sheet.

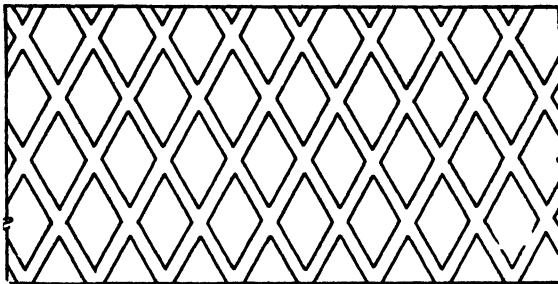

Plain expanded metal

FIG. 10-6

Expanded metal is widely used for reinforcing concrete in foundations, roads, floors, bridges, etc. It is also used as lathing material and for partitions.

**(5) Flat bars:**

These are available in suitable widths varying from 10 mm to 400 mm with thickness varying from 3 mm to 40 mm. They are widely used in the construction of steel grillwork for windows and gates.

**(6) I-sections:**

These are popularly known as *rolled steel joists* or *beams*. It consists of two flanges connected by a web as shown in fig. 10-7. It is designated by overall depth, width of flange and weight per metre length. They are available in various sizes varying from 75 mm  $\times$  50 mm at 6.10 kg to 600 mm  $\times$  210 mm at 99.50 kg. Fig. 10-7 shows a joist of size 300 mm  $\times$  150 mm at 37.70 kg. Wide flange beams are available in sizes varying from 150 mm  $\times$  100 mm at 17.00 kg to 600 mm  $\times$  250 mm

at 145.10 kg. Beams suitable for columns are available in H-sections which vary in sizes from 150 mm  $\times$  150 mm at 27.10 kg to 450 mm  $\times$  250 mm at 92.50 kg.

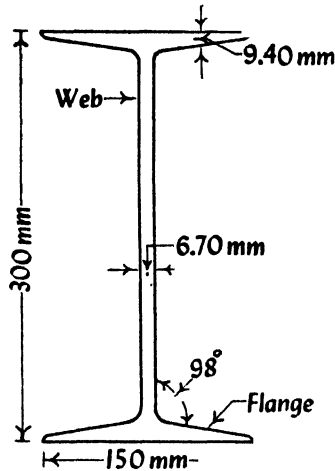

I—Section

FIG. 10-7

R. S. joists are economical in material and they are suitable for floor beams, lintels, columns, etc. The economy in material is achieved by concentrating the material in two flanges where bending stresses are maximum.

### (7) Plates:

The plate sections of steel are available in different sizes with thickness varying from 5 mm to 50 mm. The corresponding weights per square metre are 39.20 kg and 392.50 kg respectively. They are used mainly for the following *purposes* in structural steelwork:

- (i) to connect steel beams for extension of the length;
- (ii) to serve as tensional members of steel roof truss; and
- (iii) to form built-up sections of steel.

### (8) Ribbed-torsteel bars:

These bars are produced from ribbed-torsteel which is a deformed high strength steel. These bars have ribs or projections on their surface and they are produced by controlled

cold twisting of hot-rolled bars. Each bar is to be twisted individually and it is tested to confirm the standard requirements. Ribbed-torsteel bars are available in sizes varying from 6 mm to 50 mm diameter, with the corresponding weights per metre length as 0.222 kg and 15.41 kg. These bars are widely used as reinforcement in concrete structures such as buildings, bridges, docks and harbour structures, roads, irrigation works, pile foundations, pre-cast concrete works, etc. Following are the *advantages* of ribbed-torsteel bars:

- (i) It is possible to bend these bars through  $180^\circ$  without formation of any cracks or fractures on their outside surface.
- (ii) It is possible to weld certain type of ribbed-torsteel bars by electric flash butt-welding or arc welding.
- (iii) There is overall reduction in reinforcement cost to the extent of about 30 to 40 per cent when these bars are used.
- (iv) These bars are easily identified as they have got peculiar shape.
- (v) These bars possess better structural properties than ordinary plain round bars. It is, therefore, possible to design with higher stresses.
- (vi) These bars possess excellent bonding properties and hence, end hooks are not required.
- (vii) They can be used for all major types of reinforced concrete structures.
- (viii) They serve as efficient and economical concrete reinforcement.
- (ix) When these bars are used, the processes of bending, fixing and handling are simplified to a great extent. It results into less labour charges.

**(9) Round bars:**

These are available in circular cross-sections with diameters varying from 5 mm to 250 mm. They are widely used as reinforcement in concrete structures, construction of steel grillwork, etc. The commonly used cross-sections have

diameters varying from 5 mm to 25 mm with the corresponding weights per metre length as 0.15 kg and 3.80 kg respectively.

**(10) Square bars:**

These are available in square cross-section with sides varying from 5 mm to 250 mm. They are widely used in the construction of steel grillwork, for windows, gates, etc. The commonly used cross-sections have sides varying from 5 mm to 25 mm with corresponding weights per metre length as 0.20 kg and 4.90 kg respectively.

**(11) T-sections:**

The shape of this section is like that of letter T and it consists of flange and web as shown in fig. 10-8. It is designated by overall dimensions and thickness. These sections are available in sizes varying from 20 mm × 20 mm × 3 mm to 150 mm × 150 mm × 10 mm. The corresponding weights per metre length are 0.90 kg and 22.80 kg respectively. Fig. 10-8 shows T-section of size 100 mm × 100 mm × 10 mm with weight per metre length as 15.00 kg. Special T-sections with unequal sides, bulbs at the bottom edge of web, etc. are also available. These sections are widely used as members of steel roof trusses and to form built-up sections.

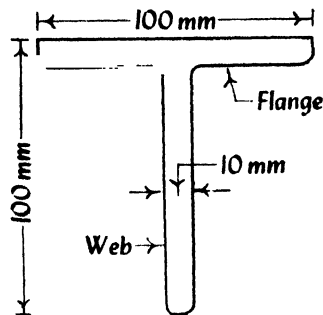

T-section  
FIG. 10-8

In addition to eleven standard shapes, rolled steel sections are also available in miscellaneous sections such as acute

and obtuse angle sections, rail sections, trough sections and z-sections. These miscellaneous sections are used to a limited extent in the structural steelwork.

### **Mechanical treatment of steel:**

The purpose of giving mechanical treatment to steel is to give desired shape to ingots so as to make steel available in market forms. The mechanical treatment of steel may be hot working or cold working. Hot working is very common. Following are the operations involved in mechanical treatment of steel:

- (1) Drawing
- (2) Forging
- (3) Pressing
- (4) Rolling.

Each operation will now be briefly described.

#### **(1) *Drawing:***

This operation is carried out to reduce the cross-section and to increase the length proportionately. In this operation, the metal is drawn through dies or specially shaped tools. Drawing is continued till wire of required diameter or cross-section is obtained. This process is used to prepare wires and rods.

#### **(2) *Forging:***

This operation is carried out by repeated blows under a power hammer or a press. The metal is heated above the critical temperature range. It is then placed on anvil and subjected to blows of hammer. This process increases the density and improves grain size of metal. Riveting belongs to forging operations. This process is used for the manufacture of bolts, cramps, etc.

Steel may be either forged free or die-forged. In the former case, steel is free to spread in all directions as it is hammered. In the latter case, steel flows under the blows of a hammer to fill the inside of a die and the excess material is forced out through a special groove and then it is cut off. Die-forged parts have very accurate dimensions.

### (3) *Pressing:*

This is a slow process and it is carried out in an equipment known as *press*. The main *advantage* of this process is that it does not involve any shock.

A press consists mainly of a die and a punch. Die and punch are suitably shaped to get article of desired shape. The metal is placed on the die and punch is then lowered under a very heavy pressure. The metal is thus pressed between die and punch and article of desired shape is obtained. For preparing articles with wide changes of shape, pressing is to be carried out in different stages.

This process is useful when a large number of similar engineering articles are to be produced.

### (4) *Rolling:*

This operation is carried out in specially prepared rolling mills. Ingots, while still red hot, are passed in succession through different rollers until articles of desired shapes are obtained. Various shapes such as angles, channels, flats, joists, rails, etc. are obtained by the process of rolling. It is also possible to prepare jointless pipe with the help of this process. The solid rod is bored by rollers in stages until the pipe of required diameter and thickness is obtained.

### **Heat treatment processes:**

It is possible to alter the properties of steel by heating and cooling steel under controlled conditions. The term *heat treatment* is used to indicate the process in which the heating and cooling of solid steel is involved to change the structural or physical properties of steel. Thus in heat treatment process, the heating and cooling of steel are carried out according to a strictly predetermined temperature schedule with the result that steel undergoes structural changes and acquires specific mechanical properties.

Following are the *purposes* of heat treatment:

- (i) to alter magnetic properties of steel,
- (ii) to change the structure of steel,
- (iii) to increase resistance to heat and corrosion,

- (iv) to increase surface hardness,
- (v) to make steel easily workable, and
- (vi) to vary strength and hardness.

The principal processes involved in heat treatment of steel are as follows:

- (1) Annealing
- (2) Case hardening
- (3) Cementing
- (4) Hardening
- (5) Nitriding
- (6) Normalising
- (7) Tempering.

**(1) Annealing:**

The main object of this process is to make the steel soft so that it can be easily worked upon with a machine. Annealing also causes the following effects:

- (i) refinement of grain without serious loss of ductility, and
- (ii) release of internal stresses developed during previous operations in manufacturing.

Following is the procedure for annealing:

- (i) Steel to be annealed is heated to the desired temperature. The temperature depends upon the carbon content of steel and it is about 50°C to 55°C above the critical temperature. Table 10-2 shows the temperature to be kept during annealing for steels with different carbon contents.

**TABLE 10-2**  
**ANNEALING TEMPERATURE**

Sr.No.	Range of annealing temperature	Carbon content of steel
1.	871 to 925	Below 0.12 %
2.	843 to 870	0.13 to 0.29 %
3.	816 to 842	0.30 to 0.49 %
4.	788 to 815	0.50 to 1.00 %

- (ii) After the desired temperature is achieved, steel is held at the annealing heat till it is thoroughly heated. The time for which annealing tempera-

ture is to be maintained will depend on type of furnace, nature of work, etc. In general, it may be mentioned that this time should be just sufficient for making the carbon dissolved into and diffused through the material.

- (iii) Steel is then allowed to cool slowly in the furnace in which it was heated.

## (2) *Case hardening:*

In this treatment, the core of specimen remains tough and ductile and at the same time, the surface becomes hard. Such a result is achieved by increasing the carbon content at the surface.

Following is the procedure of case hardening:

- (i) The article to be carburized is held in the carburizing mixture for a definite time and at definite temperature. The time and temperature will depend upon the depth of case required and composition of steel. The usual period is 6 to 8 hours and the usual temperature range is 900°C to 950°C.
- (ii) After carburizing, the article is treated in one of the following ways:
  - (a) It is quenched directly from box at carburizing temperature.
  - (b) It is cooled slowly in the carburizing box and then it is reheated and quenched.
  - (c) It is cooled slowly in the carburizing box and then it is reheated twice and also quenched twice.

The above is the general process of case hardening. Various other useful case hardening processes have been developed such as cyaniding, induction hardening, nitriding, flame hardening, etc. These processes adopt a specially prepared carburizing mixture and specially designed furnace.

### *Depth of case hardening:*

Following factors affect the depth of case hardening:

- (i) period of treatment,
- (ii) quality and nature of carburizing mixture, and
- (iii) temperature of furnace.

It is observed that at higher temperature of furnace, depth of case hardening is more. Further, if period of treatment is about 4 to 6 hours, depth of case hardening is about 0.50 mm to 1 mm and if period of treatment is increased to about 18 hours or so, depth may be about 3 mm or so.

*Carburizing mixtures :*

Following are the carburizing mixtures which are commonly used in the process of case hardening:

- (i) animal charcoal,
- (ii) bone and horn parings,
- (iii) cyanides,
- (iv) finely cut leather pieces, and
- (v) wood charcoal and soda ash, proportion being 95% and 5% respectively.

The last one is more commonly used. Animal charcoal is also sometimes preferred as nitrogen contained in it helps the carbon to unite more rapidly with iron.

*Precautions in case hardening :*

Following precautions are to be taken in the process of case hardening:

- (i) If articles are of alloy steels, they should be quenched in oil.
- (ii) Quenching should preferably be carried out in water. But for articles with unequal or uneven shapes or thickness, oil quenching should be adopted.
- (iii) The article should be placed in such a way that it can expand freely in all directions.
- (iv) The article to be treated should be clean and free from dirt, grease, oil, rust, etc.
- (v) The box in which the process is to be carried out should be cemented with fire-clay. It should be seen that air is thoroughly excluded from the box.
- (vi) The thickness of carburizing layer should be at least 25 mm all round the article.

### (3) **Cementing:**

In this process or technique, the skin of the steel is saturated with carbon. The process consists in heating of the steel in a carbon rich medium between the temperature of 880° C to 950° C.

### (4) **Hardening:**

The object of this process is just the reverse of that of the annealing process. Steel is to be made hard by this process whereas it is made soft by the annealing process.

The process of hardening is just similar to that of annealing except that there is difference in rate of cooling. In hardening process, cooling is to be carried out at controlled rate. Such a controlled rate of cooling is known as *quenching*.

Following are the mediums of quenching:

#### (i) *Air:*

The hot article is allowed to cool down in still air. A mild quench is obtained by this medium.

#### (ii) *Oil:*

The hot article is dropped in oil to cool down. Quenching in oil is quite slow. But it helps in preventing the quenching cracks developed due to rapid expansion of the article.

#### (iii) *Water:*

This is the most commonly adopted medium for quenching. The hot article is dropped in water to cool down. It is used for carbon steels and for medium carbon low alloy steels.

### (5) **Nitriding:**

The process of saturating the surface layer of steel with nitrogen by heating is known as nitriding. The heating is carried out between the temperature 500° C to 700° C in an atmosphere of ammonia. The thickness of nitriding layer may vary from 0.01 mm to 1.00 mm. The treatment makes the steel hard and increases its resistance to corrosion, wear and fatigue.

### (6) **Normalising:**

The object of this process is to restore steel structure to normal condition and it is adopted when structure of steel is seriously disturbed for any reason. This process also makes

the material reasonably ductile without seriously affecting its strength.

Following is the procedure of normalising:

- (i) Steel is heated, the usual temperature range being  $843^{\circ}\text{C}$  to  $954^{\circ}\text{C}$ .
- (ii) It is then allowed to cool down in air. As cooling is more rapid, less time is available to achieve equilibrium and as a result of this, the material becomes harder than fully annealed steel.

### (7) **Tempering:**

This process is applied to steels which are treated with the hardening process. This process achieves the following *two* objects:

- (i) It develops the desired combination of hardness and ductility.
- (ii) It relieves high residual stresses developed during hardening process.

Following is the procedure adopted for tempering:

- (i) The article after being quenched in hardening process is reheated to suitable temperature. This temperature should be below the critical temperature.
- (ii) The temperature is maintained for a certain period. The duration of period depends on quality of steel required and composition of steels.
- (iii) The article is then allowed to cool down in still air.

### **Properties of mild steel:**

- (1) It can be magnetised permanently.
- (2) It can be readily forged and welded.
- (3) It cannot be easily hardened and tempered.
- (4) It has fibrous structure.
- (5) It is malleable and ductile.
- (6) It is not easily attacked by salt water.
- (7) It is tougher and more elastic than wrought-iron.
- (8) It is used for all types of structural work.

- (9) It rusts easily and rapidly.
- (10) Its melting point is about 1400°C.
- (11) Its specific gravity is 7.80.
- (12) Its ultimate compressive strength is about 8 to 12 tonnes per cm<sup>2</sup>.
- (13) Its ultimate tensile and shear strength are about 6 to 8 tonnes per cm<sup>2</sup>.

**Properties of hard steel:**

- (1) It can be easily hardened and tempered.
- (2) It can be magnetised permanently.
- (3) It cannot be readily forged and welded.
- (4) It has granular structure.
- (5) It is not easily attacked by salt water.
- (6) It is tougher and more elastic than mild steel.
- (7) It is used for finest cutlery, edge tools and for parts which are to be subjected to shocks and vibrations.
- (8) It rusts easily and rapidly.
- (9) Its melting point is about 1300°C.
- (10) Its specific gravity is 7.90.
- (11) Its ultimate compressive strength is about 14 to 20 tonnes per cm<sup>2</sup>.
- (12) Its ultimate shear strength is about 11 tonnes per cm<sup>2</sup>.
- (13) Its ultimate tensile strength is about 8 to 11 tonnes per cm<sup>2</sup>.

**Corrosion of ferrous metals:**

The term *corrosion* is used to indicate the conversion of metals by natural agencies into various compounds. The term *rusting* is used to refer corrosion of ferrous metals. It is observed that rusting of cast-iron is less, that of steel is much more and that of wrought-iron is medium.

**Theory of corrosion:**

The chemical reactions involved in corrosion are as follows:

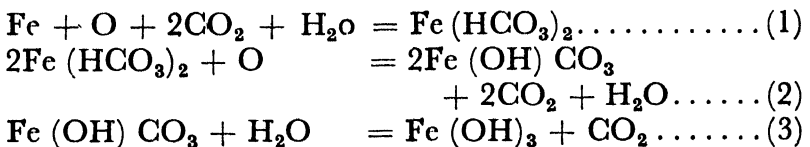

The combined action of oxygen, carbon dioxide and moisture on iron results into soluble ferrous bicarbonate  $\text{Fe}(\text{HCO}_3)_2$  as shown by reaction (1). This ferrous bicarbonate is then oxidised to basic ferric carbonate  $2\text{Fe}(\text{OH})\text{CO}_3$  as shown by reaction (2). This basic ferric carbonate is converted into hydrated ferric oxide and carbon dioxide is liberated as shown by reaction (3).

The above theory of corrosion is supported by the following *two* observations:

- (1) Analysis of rust shows small amounts of ferrous bicarbonate, ferric carbonate and hydrated ferric oxide.
- (2) If carbon dioxide is excluded by immersing iron into a solution of sodium hydroxide or lime water, intensity of rusting is considerably decreased.

The corrosion of metal is also explained by the electrolytic theory. According to this theory, metal contains anodic and cathodic areas and these areas, when connected by electrolytes such as water, moisture, aqueous solutions, etc. cause corrosion. These areas are developed in metal due to various reasons such as differences in metal composition, unequal concentration of oxygen on different parts of metal surface, etc.

### ***Preventive measures for corrosion:***

Following are the methods which are usually adopted to prevent corrosion:

- (1) Coal tarring
- (2) Electroplating
- (3) Embedding in cement concrete
- (4) Enamelling
- (5) Galvanising
- (6) Metal spraying .
- (7) Painting
- (8) Parkersing
- (9) Sherardising
- (10) Tin plating.

Each method will now be briefly described.

(1) *Coal tarring:*

In this method, coal tar is applied on the surface of iron. Its appearance is objectionable and hence it is adopted for work below ground or at places where appearance is not of much importance.

(2) *Electroplating:*

In this method, a thin layer of chromium, copper or nickle is laid on the surface of ferrous metal with the help of electric current. The surface so formed is smooth and shining.

(3) *Embedding in cement concrete:*

If steel is embedded in cement concrete, as in case of reinforced cement concrete construction, it is not affected by corrosion. The cement concrete should, however, be properly laid and cured so that it does not contain voids or cracks. There should also be enough cover of concrete on steel surface.

(4) *Enamelling:*

In this method, surface of iron is glazed by melting a suitable flux on it. This method is used for giving ornamental finish to iron surface.

(5) *Galvanising:*

In this method, the ferrous metal is thoroughly cleaned and it is then dipped in a bath of molten zinc. The layer of zinc protects iron from rusting.

(6) *Metal spraying:*

In this method, the ferrous metal is covered with a spray of vaporised aluminium, tin or zinc. The equipment includes a pistol, a bundle of wires of coating metal, compressed air, oxygen and a suitable fuel gas. An oxy-hydrogen flame is produced inside the nozzle of piston and it results in the melting of wire of coating metal. This molten metal is forced by the compressed air and it is deposited on iron surface. Spraying is simple and it gives a thin film of uniform thickness.

(7) *Painting:*

In this method, the surface of ferrous metal is covered with a layer of suitable paint. The iron surface should be

The combined action of oxygen, carbon dioxide and moisture on iron results into soluble ferrous bicarbonate  $\text{Fe}(\text{HCO}_3)_2$  as shown by reaction (1). This ferrous bicarbonate is then oxidised to basic ferric carbonate  $2\text{Fe}(\text{OH})\text{CO}_3$  as shown by reaction (2). This basic ferric carbonate is converted into hydrated ferric oxide and carbon dioxide is liberated as shown by reaction (3).

The above theory of corrosion is supported by the following *two* observations:

- (1) Analysis of rust shows small amounts of ferrous bicarbonate, ferric carbonate and hydrated ferric oxide.
- (2) If carbon dioxide is excluded by immersing iron into a solution of sodium hydroxide or lime water, intensity of rusting is considerably decreased.

The corrosion of metal is also explained by the electrolytic theory. According to this theory, metal contains anodic and cathodic areas and these areas, when connected by electrolytes such as water, moisture, aqueous solutions, etc. cause corrosion. These areas are developed in metal due to various reasons such as differences in metal composition, unequal concentration of oxygen on different parts of metal surface, etc.

***Preventive measures for corrosion:***

Following are the methods which are usually adopted to prevent corrosion:

- (1) Coal tarring
- (2) Electroplating
- (3) Embedding in cement concrete
- (4) Enamelling
- (5) Galvanising
- (6) Metal spraying .
- (7) Painting
- (8) Parkersing
- (9) Sherardising
- (10) Tin plating.

Each method will now be briefly described.

(1) *Coal tarring :*

In this method, coal tar is applied on the surface of iron. Its appearance is objectionable and hence it is adopted for work below ground or at places where appearance is not of much importance.

(2) *Electroplating :*

In this method, a thin layer of chromium, copper or nickle is laid on the surface of ferrous metal with the help of electric current. The surface so formed is smooth and shining.

(3) *Embedding in cement concrete :*

If steel is embedded in cement concrete, as in case of reinforced cement concrete construction, it is not affected by corrosion. The cement concrete should, however, be properly laid and cured so that it does not contain voids or cracks. There should also be enough cover of concrete on steel surface.

(4) *Enamelling :*

In this method, surface of iron is glazed by melting a suitable flux on it. This method is used for giving ornamental finish to iron surface.

(5) *Galvanising :*

In this method, the ferrous metal is thoroughly cleaned and it is then dipped in a bath of molten zinc. The layer of zinc protects iron from rusting.

(6) *Metal spraying :*

In this method, the ferrous metal is covered with a spray of vaporised aluminium, tin or zinc. The equipment includes a pistol, a bundle of wires of coating metal, compressed air, oxygen and a suitable fuel gas. An oxy-hydrogen flame is produced inside the nozzle of piston and it results in the melting of wire of coating metal. This molten metal is forced by the compressed air and it is deposited on iron surface. Spraying is simple and it gives a thin film of uniform thickness.

(7) *Painting :*

In this method, the surface of ferrous metal is covered with a layer of suitable paint. The iron surface should be

thoroughly cleaned and paint should be properly applied. Paint may be done with brushes or paint may be filled in a pistol and sprayed on iron surface.

(8) *Parkering* :

In this method, the article to be treated for corrosion is immersed for a period of about an hour or so into a hot water bath of a chemical, known as *Pareo*. Insoluble phosphates are formed on the surface of article due to chemical reactions and these phosphates keep away the moisture.

(9) *Sherardising* :

In this method, the article to be treated for corrosion is cleaned and it is then covered with dust of pure zinc. It is then heated to a suitable temperature of 250°C to 450°C in an air-tight steel box. Zinc then melts and it combines with metal and forms a protective layer on metal surface. The surface so formed is durable and can be easily polished.

(10) *Tin plating* :

In this method, the ferrous metal is thoroughly cleaned with the help of dilute solution of acid and it is then dipped in a bath of molten tin. Surplus tin may be removed by rolling. The durability of utensils for food and equipments for dairy can be considerably increased by tin plating. The process can also be done with the help of electricity.

## QUESTIONS

1. Describe the various processes adopted to manufacture steel.
2. State various uses of steel.
3. What are the factors which affect physical properties of steel?
4. Write short notes on:
  - (1) Magnetic properties of steel
  - (2) Normalising
  - (3) Tempering
  - (4) Hardening
  - (5) Metal spraying
  - (6) L. D. process
  - (7) Ribbed-steel bars
  - (8) Duplex process.
5. State the defects in steel.
6. Enumerate various market forms of steel.

7. What are the operations involved in the mechanical treatment of steel?
8. What are the purposes of heat treatment processes for steel?
9. Describe the process of annealing.
10. Discuss the process of case hardening.
11. Mention the properties of mild steel.
12. Give sketches of the following:
  - (1) Bessemer converter
  - (2) Open-hearth furnace
  - (3) Plain expanded metal
  - (4) I-section.
13. Mention the properties of hard steel.
14. What is corrosion? Explain its theory.
15. Describe the measures adopted to prevent corrosion of ferrous metals.
16. Distinguish between the following:
  - (1) Mild steel and hard steel
  - (2) Galvanising and tin plating
  - (3) Cold shortness and red shortness
  - (4) Equal angle section and unequal angle section
  - (5) Annealing and hardening
  - (6) Ribbed-torsteel bars and round bars
  - (7) Electroplating and galvanising
  - (8) Rolling and forging
  - (9) Drawing and rolling.
17. Give reasons for the following:
  - (1) Blister steel cannot be used for making edge tools.
  - (2) Great economy can be achieved in open-hearth process by providing regenerative chambers on either side of the hearth.
  - (3) Steel containing more than 1.5 per cent of manganese loses its structural value.
  - (4) R. S. joists are economical in material.
  - (5) Basic slag obtained from open-hearth process can be used as good fertiliser.
  - (6) For ribbed-torsteel bars, end hooks are not required.
  - (7) Bessemer converter is mounted on two horizontal trunnions.

# Chapter 11

## NON-FERROUS METALS AND ALLOYS

### **Non-ferrous metals:**

Following non-ferrous metals which have limited use in engineering structures will be studied in this chapter:

- I. Aluminium
- II. Cobalt
- III. Copper
- IV. Lead
- V. Magnesium
- VI. Nickel
- VII. Tin
- VIII. Zinc.

### **I. Aluminium:**

Aluminium occurs in abundance on the earth's surface. It is available in various forms such as oxides, sulphates, silicates, phosphates, etc. But it is commercially produced mainly from bauxite ( $\text{Al}_2\text{O}_3 \cdot 2\text{H}_2\text{O}$ ) which is hydrated oxide of aluminium.

### ***Manufacture:***

Aluminium is extracted from bauxite ores as follows:

- (1) Bauxite is purified.
- (2) It is then dissolved in fused cryolite which is a double fluoride of aluminium and sodium,  $\text{AlF}_3$ ,  $3\text{NaF}$ .
- (3) This solution is then taken to an electric furnace and aluminium is separated out by electrolysis.

### ***Properties:***

Following are the properties of aluminium:

- (1) It is a good conductor of heat and electricity.

- (2) It is a white metal with bluish tinge.
- (3) It is rarely attacked by nitric acid, organic acid or water. It is highly resistant to corrosion.
- (4) It is light in weight, malleable and ductile.
- (5) It melts at about 658°C.
- (6) It possesses great toughness and tensile strength.
- (7) It readily dissolves in hydrochloric acid.
- (8) Its specific gravity is about 2.70.

### **Uses:**

This metal is chiefly used for making parts of aeroplane, utensils, paints, electric wires, window frames, glazing bars, corrugated sheets, structural members, foils, posts, panels, balustrades, etc.

After the second world war, this material has been tried for structural members. Its use as structural material is therefore very recent. But it has made good progress during this period and research is yet going on to make maximum use of this metal as structural material. Following are some of the illustrations to support the above fact:

- (1) In England, an exhibition was held in 1951. At this exhibition, a dome of aluminium, known as '*Dome of Discovery*' was also installed. Diameter of dome was about 103 m. Such domes can be used to cover small reservoirs.
- (2) Movable bridges of aluminium are made in New Zealand. Such bridges are extremely useful in case of an emergency.
- (3) A girder of aluminium is made for a godown in England. Span of this girder is about 62 m.
- (4) In many countries of the world, foot-bridges of aluminium are made and these are working quite satisfactorily.
- (5) In Germany, a bridge of aluminium is made. Its span is about 44 m and its total width, including projections of footpaths of width 45 cm on either side, is 4.35 m.

- (6) Aluminium has also been successfully tried for movable constructions such as cranes, movable bridges, etc.
- (7) A gigantic aerodrome has been prepared from aluminium in England. Portal frames with a span of about 65 m are adopted in the design of this aerodrome. Had these frames been made from steel, their weight would have been about seven times more than that of aluminium frames.

It is thus seen that aluminium has been receiving more attention for its use as a structural material. It is quite likely, therefore, that in near future, aluminium may secure a distinct place among structural materials.

## II. Cobalt:

Cobalt is found to occur in free state in meteorites. Its two important ores are arsenide and sulphoarsenide.

### *Manufacture:*

The ores are purified and they are then fused with limestone or sand in a blast furnace. It gives impure oxide of cobalt. Impurities from this oxide of cobalt are removed by various wet processes.

### *Properties:*

Following are the properties of cobalt:

- (1) If cobalt is red hot, it can decompose steam.
- (2) If it is in a finely ground powder form, it may absorb hydrogen to the extent of about 150 times its volume.
- (3) It is a lustrous white metal.
- (4) It is magnetic and can retain its magnetic properties upto a temperature of about 1100°C.
- (5) It is malleable and ductile.
- (6) It is not affected by atmosphere at ordinary temperature.
- (7) It is not attacked by alkalis.
- (8) Its specific gravity is 8.80.

**Uses:**

Cobalt is widely used in the preparation of special alloy steels, ceramic products, television articles, etc.

**III. Copper:**

Copper occurs in practically all important countries of the world. Its principal ores are Cuprite  $\text{Cu}_2\text{O}$ , Copper glance  $\text{Cu}_2\text{S}$ , Copper pyrites  $\text{CuFeS}_2$ , Malachite  $\text{CuCO}_3 \cdot \text{Cu}(\text{OH})_2$  and Azurite  $2\text{CuCO}_3 \cdot \text{Cu}(\text{OH})_2$ .

**Manufacture:**

Copper is manufactured by a laborious method and the treatment to be adopted largely depends on the quality of copper ores. Following is the general outline of the modern process of copper manufacture:

- (1) The ores, usually pyrites, are crushed and they are then calcined in a reverberatory furnace.
- (2) The calcined ores are mixed with silica and a small quantity of coke. The mixture is then smelted in a blast furnace.
- (3) The melted metal is oxidised in Bessemer converter. It gives blister copper.
- (4) Impurities contained in blister copper are removed by melting it in a reverberatory furnace in presence of air.
- (5) Slag is removed and pure copper to the extent of about 99.70 per cent is obtained.
- (6) Very pure copper or 100 per cent copper is obtained by the process of electrolysis.

**Properties:**

Following are the properties of copper:

- (1) It becomes brittle just below its melting point.
- (2) It can be worked in hot or cold condition. But it cannot be welded.

- (3) It has a peculiar red colour.
- (4) It is a good conductor of heat and electricity.
- (5) It is attacked by steam at white heat.
- (6) It is not attacked by dry air, but moist air gives a green coating to copper surface.
- (7) It is not attacked by water at any temperature.
- (8) It is malleable, ductile and soft.
- (9) It melts at  $1083^{\circ}\text{C}$ .
- (10) Its specific gravity is 8.90.

***Uses:***

The market forms of copper are ingots, sheets, tubes and wires. It is extensively used for making electric cables, alloys, household utensils, electroplating, lighting conductors, dowels in stone masonry, etc.

**IV. Lead:**

Lead occurs occasionally in free state in nature. In combined form, it mainly occurs as sulphide, ore being known as Galena,  $\text{PbS}$ . This is the most important and widely distributed ore of lead.

***Manufacture:***

Lead is extracted from galena ores as follows:

- (1) The ores are concentrated.
- (2) Coke and metallic iron are added to ores.
- (3) The mixture is then smelted in a blast furnace.
- (4) Impure lead is obtained which is further purified in a reverberatory furnace.

***Properties:***

Following are the properties of lead:

- (1) It can be cut with a knife.
- (2) It makes impression on paper.
- (3) It melts at  $326^{\circ}\text{C}$ .
- (4) It is a lustrous metal with bluish-grey colour.

- (5) It is converted into litharge, when heated strongly in presence of air or oxygen.
- (6) It is not attacked by dry air, but moist air takes away its bright metallic lustre.
- (7) It possesses little tenacity.
- (8) It is soft.
- (9) Its specific gravity is 11.36.

**Uses:**

Lead is widely used for making shots, bullets, alloys, storage cells, sanitary fittings, cisterns, waterproof and acid-proof chambers, gas pipes, roof gutters, printing types, damp-proof courses of buildings, cable coverings, preparation of lead oxides for paints, etc.

**V. Magnesium:**

Magnesium does not occur in free state in nature. Its principal ores are magnesite  $\text{MgCO}_3$ , dolomite  $\text{CaCO}_3$ ,  $\text{MgCO}_3$ , kieserite  $\text{MgSO}_4 \cdot \text{H}_2\text{O}$  and carnallite  $\text{MgCl}_2 \cdot 6\text{H}_2\text{O}$ .

**Manufacture:**

For obtaining magnesium on a small scale, anhydrous magnesium chlorite is heated with sodium in presence of coal gas. For large scale production, magnesium is obtained by the electrolysis of carnallite.

**Properties:**

Following are the properties of magnesium:

- (1) It burns with a dazzling white light when heated in air.
- (2) It carries away heat easily.
- (3) If it is in the form of finely divided particles, it burns readily and easily.
- (4) If strongly heated, it can decompose steam.
- (5) It is a silver-white metal.
- (6) It is ductile and malleable.
- (7) It is not affected by alkalis.
- (8) Its melting point is  $651^\circ\text{C}$ .
- (9) Its thermal coefficient of expansion is high.

**Uses:**

Magnesium is used in photography, fire-works, signalling, etc. It alone cannot be used for structural work. But some of its alloys may be employed for some structural parts.

**VI. Nickel:**

Nickel occurs in free state in meteorites. In combination, it chiefly occurs as sulphide ores and silicate ores.

**Manufacture:**

Nickel is extracted from sulphide ores as follows:

- (1) The ores are cleaned of earthy matter.
- (2) They are roasted in heaps.
- (3) The roasted ores are smelted in blast furnace along-with limestone, quartz and coke.
- (4) The molten mixture of nickel and copper sulphide collects at the bottom. It is led to Bessemer converter with basic lining.
- (5) After treatment in converter, metallic nickel is obtained by repeated smelting and electrolysis.

**Properties:**

Following are the properties of nickel:

- (1) If nickel is red hot, it can decompose steam.
- (2) If it is in a finely ground powder form, it may absorb hydrogen to the extent of about 17 times its volume.
- (3) It is a greyish white lustrous metal.
- (4) It is capable of taking a high polish.
- (5) It is fairly resistant to the actions of atmosphere and it becomes dull after a long time.
- (6) It is hard, malleable and magnetic.
- (7) It is not attacked by fused alkalis.
- (8) Its resistance to corrosion is high.
- (9) Its specific gravity is 8.90.

**Uses:**

Nickel is widely used as a coating for other metals and for preparation of alloys.

**VII. Tin:**

Tin occurs chiefly as tinstone or cassiterite which is its oxide,  $\text{SnO}_2$ . It is also available in nodules which are known as *stream tin*.

**Manufacture:**

Tin is extracted from its ore as follows:

- (1) The ore is crushed and washed to remove impurities.
- (2) It is then calcined in a revolving calciner.
- (3) The calcined ore is allowed to cool.
- (4) After cooling, it is washed with water.
- (5) The liquid is allowed to rest. The refined tinstone collects at the bottom as it is heavy.
- (6) It is then smelted in a furnace with anthracite coal and sand.
- (7) It is finely refined in a reverberatory furnace to obtain commercially pure tin.

**Properties:**

Following are the properties of tin:

- (1) If a bar of tin is bent, a peculiar noise occurs which is sometimes known as *cry of tin*.
- (2) It becomes brittle when heated to a temperature of about  $200^\circ\text{C}$ .
- (3) It melts at  $232^\circ\text{C}$ .
- (4) It is a white metal with a brilliant lustre.
- (5) It is not affected by dry air.
- (6) It is not attacked by pure water.
- (7) It is soft and malleable.
- (8) Its specific gravity is 7.30.

**Uses:**

Tin is used for preparing alloys, utensils or vessels for household and technical use tin-foils, etc. It is also used for giving a protective coating to other metals.

**VIII. Zinc:**

Zinc does not occur in free state in nature. Its principal ores are zincite  $ZnO$ , franklinite  $ZnO$ ,  $Fe_2O_3$ , calamine  $ZnCO_3$  and zinc blende  $ZnS$ .

**Manufacture:**

Zincite or zinc oxide is heated in an electric furnace. Zinc is liberated in the form of vapour. This vapour is then condensed to get metallic zinc.

**Properties:**

Following are the properties of zinc:

- (1) It burns with a greenish white flame when strongly heated in air.
- (2) It may be drawn into wires and rolled into sheets between temperature range of  $100^\circ C$  to  $150^\circ C$ .
- (3) It melts at  $419^\circ C$ .
- (4) It is a bluish white metal.
- (5) It is brittle at the ordinary temperature.
- (6) It is not affected by dry air.
- (7) It is not attacked by pure water.
- (8) Its specific gravity is 6.86.

**Uses:**

Zinc is used in electric cells, for galvanising, in the preparation of alloys, paints, etc.

**Alloys:**

An alloy is an intimate mixture of two or more metals. The process for making an alloy is as follows:

- (1) The more infusible metal is first melted in a fire-clay crucible.

- (2) The other metal or metals are then added subsequently in order of their infusibility.
- (3) The contents are continuously stirred to form a homogeneous mass.
- (4) The molten mixture is then cast into suitable moulds.

It may, however, be noted that an alloy does not merely indicate a mechanical mixture of two or more metals. As a matter of fact, the properties of an alloy are entirely different from those of its constituents.

Following important alloys will be studied:

- I. Aluminium alloys
- II. Copper alloys
- III. Magnesium alloys
- IV. Nickel alloys
- V. Steel alloys.

### **I. Aluminium alloys:**

These are preferred to pure aluminium for constructional purposes. They are hard and strong. They contain copper, silicon, magnesium, manganese, silicon, iron and nickel in various combinations. Following are the important alloys of aluminium:

- (1) Aldural
- (2) Aluminium bronze
- (3) Duralumin
- (4) Y-alloy.

#### **(1) Aldural:**

This is also known as *Alclad* and it is duralumin with a thin coating of pure aluminium. The thickness of layer of pure aluminium is about 5 per cent of thickness of core and such a layer prevents corrosion due to salt water.

#### **(2) Aluminium bronze:**

This is in fact copper alloy. It consists of 10 per cent of aluminium and 90 per cent of copper. It is very strong and is used for die-casting, pump rods, etc.

**(3) Duralumin:**

This is a very important alloy of aluminium. Its composition is as follows:

Aluminium.....	94 %
Copper .....	4 %
Magnesium .....	0.5 %
Manganese .....	0.5 %
Silicon.....	0.5 %
Iron.....	0.5 %
Total	100 %

Its specific gravity is about 2.85. It possesses the property of age hardening, i.e., it acquires hardness after about 2 to 3 days when quenched in water from 500°C. It is quite strong and it has high electrical conductance. It is used in aircraft industry, for making electric cables, etc.

**(4) Y-alloy:**

Following is the composition of this alloy:

Aluminium.....	92.50 %
Copper .....	4.00 %
Nickel .....	2.00 %
Magnesium .....	1.50 %
Total	100 %

This alloy is a good conductor of heat and it possesses high strength at high temperatures. It is used for making pistons of engines, cylinder heads, gear boxes, propeller blades, etc.

**II. Copper alloys:**

These alloys are broadly divided into *two* categories:

- (1) Brasses
- (2) Bronzes.

**(1) Brasses:**

Brass is an alloy of copper and zinc and minor percentages of other elements, except tin, may be added. Following are the common varieties of brass:

(i) *Cartridge brass:*

It contains 70% copper and 30% zinc. It is ductile and it possesses high tensile strength. It is used for cartridges, tubes, springs, etc.

(ii) *Delta metal:*

It contains 60% copper, 37% zinc and 3% iron. Its resistance to corrosion is high. It may even be used in place of mild steel to resist corrosion.

(iii) *Low brass:*

It contains 80% copper and 20% zinc. It is used for pump lines and ornamental metal work.

(iv) *Muntz metal:*

It contains 60% copper and 40% zinc. It has high strength. It is used for casting, condenser tubes, etc.

(v) *Naval brass:*

This is an exception to the general rule for brass. It contains about 1 per cent of tin. When one per cent of tin is added to muntz metal, it is called naval brass and when it is added to cartridge metal, it is called admiralty metal. It is used for marine and engineering castings such as condenser tubes, pump parts, motor boat shafting, etc.

(vi) *Red brass:*

It contains 85% copper and 15% zinc. It resists firmly the action of corrosion. It is used for plumbing lines, electrical sockets, etc.

(vii) *White brass:*

It contains 10% copper and 90% zinc. It is more or less similar to zinc except that addition of copper makes it hard and strong. It is used for ornamental work.

(viii) *Yellow brass:*

It contains 65% copper and 35% zinc. Its specific gravity is 8.47. It is very strong. It is used for plumbing accessories, lamp fixtures, grillwork, etc.

**(2) Bronzes:**

Bronze is an alloy of copper and tin and minor percentages of other elements, except zinc, may be added. Following are the common varieties of bronze:

**(i) Bell metal:**

It contains 82% copper and 18% tin. It is hard and brittle. It possesses resonance. It is used for making bells.

**(ii) Gun metal:**

It contains 88% copper, 10 to 8% of tin and 2 to 4% of zinc. It thus contains zinc and forms an exception to the general rule of bronze. It is tough, strong and hard. It is suitable for sound castings. It is used for making guns, bearings, etc.

**(iii) Manganese bronze:**

It contains 56 to 60 per cent copper and remaining is zinc. Following other elements are also added:

Manganese ..... 1 % maximum.

Aluminium..... 0.05% to 1%.

Lead ..... 0.4 % maximum.

Iron..... 0.40% to 1%.

This alloy resists corrosion by sea water and it is also not attacked by dilute acids. It is used for various ship fittings, shafts, axles, etc.

**(iv) Phosphor bronze:**

It contains 89% copper, 10% tin and 1% phosphorus. This alloy is hard and strong. It resists corrosion by sea water. It is used for subaqueous construction.

**(v) Speculum metal:**

It contains 67% copper and 33% tin. It is silvery in colour. It has a high reflective surface, when polished. This alloy is used in making telescopes.

**III. Magnesium alloys:**

These alloys are light and they can be easily worked. They are used to construct aeroplanes, chair frames, engine parts, etc.

Following are *two* important magnesium alloys:

- (1) Dow metal
- (2) Electron metal.

**(1) Dow metal:**

It contains 4 to 12% aluminium, 0.1 to 0.4% manganese and the rest is magnesium.

**(2) Electron metal:**

It contains 4% zinc, small percentages of copper, iron and silicon, and the rest is magnesium.

**IV. Nickel alloys:**

Following are *two* important nickel alloys:

- (1) Monel metal
- (2) Nickel silver.

**(1) Monel metal:**

This nickel alloy contains copper and small percentages of other elements. It possesses great resistance to corrosive liquids, acids, etc. It retains its physical properties at considerable high temperatures. This alloy is available in different grades and each grade has specific uses.

**(2) Nickel silver:**

This is also known as *German Silver*. It is a brass to which nickel is added. Its usual composition is as follows:

Copper	.....50 to 80 %
Zinc	.....10 to 35 %
Nickel	..... 5 to 30 %.

This alloy is of silvery white colour and it offers great resistance to corrosion. It is used for making scientific instruments, utensils, fittings, etc.

**V. Steel alloys:**

The properties of steel can be altered by adding small percentages of other elements such as manganese, nickel, copper, etc. Such steel is accordingly designated. Following are the common varieties of steel alloys:

- (1) Chrome—molybdenum steel
- (2) Chrome—nickel stainless steel
- (3) Chrome—nickel steel
- (4) Chromium steel
- (5) Chromium—vanadium steel
- (6) Cobalt steel
- (7) Copper steel
- (8) Manganese steel
- (9) Molybdenum steel
- (10) Nickel—chromium—molybdenum steel
- (11) Nickel—molybdenum steel
- (12) Nickel steel
- (13) Tungsten steel
- (14) Vanadium steel.

**(1) *Chrome—molybdenum steel:***

In this steel alloy, chromium and molybdenum are added to steel, having carbon content of 0.20 to 0.50 per cent. The percentage of chromium is about 0.4 to 1.10 and that of molybdenum is about 0.20 to 0.40. This alloy is very hard, strong and tough. This alloy is used in aircraft industry, oil industry, etc.

**(2) *Chrome—nickel stainless steel:***

This alloy of steel contains about 18 to 20 per cent of chromium and 8 to 12 per cent of nickel. It is highly resistant to corrosion. It can be cast, pressed and machined. It is not affected by acids. It is widely used for household utensils, vessels to store acids, dairy plant equipment, etc.

**(3) *Chrome—nickel steel:***

This alloy of steel contains about 0.55 to 1.75 per cent of chromium and 1.10 to 3.75 per cent of nickel. Carbon content of steel varies from 0.17 to 0.43 per cent. This alloy is tough and ductile. It possesses high elastic limit and tensile strength. It is also highly resistant to dynamic stresses. This alloy is used for aeroplanes, engine parts, bearings, pneumatic tools, gears, etc.

**(4) Chromium steel:**

This alloy is popularly known as *chrome steel*. It contains 0.70 to 1.20 per cent of chromium. Carbon content of steel varies from 0.17 to 0.55. It possesses extremely high elastic limit. It, therefore, can withstand abrasion, impact or shock. This alloy is used for cutting tools, files, coil springs for automobiles, ball bearings, etc.

**(5) Chromium—vanadium steel:**

This alloy of steel contains chromium and vanadium. The percentage of chromium is 0.70 to 0.90 and that of vanadium is 0.10 to 0.15 per cent. Carbon content of steel varies from 0.17 to 0.55 per cent. It is highly ductile and can be easily worked. It also possesses high strength. It can be easily welded. It is finely grained. This alloy is used for locomotive springs, bolts, pistons, marine engine construction, etc.

**(6) Cobalt steel:**

This alloy of steel is formed by adding cobalt to high carbon steel. It possesses magnetic properties and addition of about 35 per cent of cobalt to high carbon steel makes a permanent magnet with strong magnetic field.

**(7) Copper steel:**

This alloy of steel contains copper to the extent of about 0.15 to 0.25 per cent. It can resist atmospheric resistance in a better way than ordinary carbon steel. Except this, there are no remarkable changes in the properties of steel.

**(8) Manganese steel:**

This alloy of steel contains manganese to the extent of about 1.60 to 1.90 per cent. Carbon content of steel varies from 0.30 to 0.50 per cent. It is hard and strong. It possesses fair ductility and excellent resistance to abrasion. It has a low coefficient of expansion. This alloy is used for points and switches in railway crossings, springs, gears, burglar-proof construction, etc.

**(9) Molybdenum steel:**

This alloy of steel contains molybdenum and manganese. The percentage of molybdenum varies from 0.20 to 0.30 and that of manganese varies from 0.70 to 1.00 per cent. It is hard and strong. It offers better resistance to impact and shock. It maintains its properties at high temperatures. It can be easily welded. This alloy is used for axles, springs, bolts, scraper blades, etc.

**(10) Nickel — chromium — molybdenum steel:**

This alloy of steel contains nickel, chromium and molybdenum. It also contains small percentages of manganese, phosphorus, silicon and sulphur. The percentage of nickel varies from 0.40 to 2.00, that of chromium varies from 0.40 to 0.90 and that of molybdenum varies from 0.15 to 0.30. Carbon content of steel varies from 0.28 to 0.40. It cannot be easily welded. It does not soften at high temperatures. It can withstand dynamic stresses. This alloy is used for die-casting dies, bucket teeth of dredgers, etc.

**(11) Nickel — molybdenum steel:**

This alloy of steel contains nickel and molybdenum. It also contains small percentages of manganese, phosphorus, silicon and sulphur. The percentage of nickel varies from 1.65 to 3.75 and that of molybdenum varies from 0.20 to 0.30. Carbon content of steel varies from 0.17 to 0.23. It does not distort during quenching. It can be easily given heat treatment. It possesses good toughness. This alloy is used in petroleum industry, aircraft industry, etc.

**(12) Nickel steel:**

This alloy of steel contains 3 to 3.50 per cent of nickel. Carbon content of steel varies from 0.15 to 0.50 per cent. It is hard, ductile and resistant to corrosion. This alloy is used for boiler plates, propeller shafts, structural steel, etc.

When nickel content is about 18 to 40 per cent, it is known as *high-nickel steel*. *Invar* is a high-nickel steel alloy with 36 per cent of nickel. It has very small coefficient of thermal expansion. It is used for pendulums of clocks and other precision instruments.

**(13) Tungsten steel:**

This alloy of steel contains tungsten to the extent of about 5 to 7 per cent. Carbon content of steel varies from 0.50 to 1.00 per cent. It is hard and can maintain its cutting power at high temperature. This alloy is used for drills, lathe tools, cutters, etc.

**(14) Vanadium steel:**

This alloy of steel contains vanadium to the extent of about 0.20 per cent. It increases strength of steel. This alloy is used for springs, automobile parts, etc.

**QUESTIONS**

1. Mention the uses of non-ferrous metals which are commonly used in engineering structures.
2. State the properties of aluminium, cobalt, copper and lead.
3. Discuss the importance of aluminium as structural material.
4. Enumerate the properties of magnesium, nickel, tin and zinc.
5. Write short notes on:
  - (1) Magnesium alloys
  - (2) Nickel alloys
  - (3) Duralumin
  - (4) Molybdenum steel
  - (5) Copper steel
  - (6) Tungsten steel
  - (7) Naval brass
  - (8) Manganese bronze
  - (9) Chromium steel
  - (10) Nickel steel
  - (11) Nickel — chromium — molybdenum steel.

6. Explain the manufacturing process of the following non-ferrous metals:  
Aluminium; Copper; Lead; Nickel; Tin.
7. What is an alloy? How is it formed?
8. Enumerate various copper alloys.
9. Discuss various aluminium alloys.
10. Describe various steel alloys.
11. Distinguish between the following:
  - (1) Metal and alloy
  - (2) Duralumin and Y-alloy
  - (3) Brass and bronze
  - (4) Bell metal and gun metal
  - (5) Dow metal and electron metal
  - (6) Manganese steel and molybdenum steel
  - (7) Tungsten steel and vanadium steel
  - (8) Naval brass and admiralty metal
  - (9) White brass and yellow brass
  - (10) Monel metal and nickel silver
  - (11) Cobalt steel and copper steel
  - (12) Chrome steel and invar
  - (13) Gun metal and speculum metal
  - (14) Nickel alloy and chrome-nickel steel.
12. Give reasons for the following:
  - (1) An alloy does not merely indicate a mechanical mixture of two or more metals.
  - (2) Invar is used for pendulums of clocks and other precision instruments.
  - (3) Chromium steel can withstand abrasion, impact or shock.
  - (4) Tungsten steel is used for grills, lathe tools, cutters, etc.
  - (5) Manganese steel is used for points and switches in railway crossings.

# Chapter 12

## GLASS

### General:

Glass has been used as an engineering material since ancient times. But because of the rapid progress made in the glass industry in recent times, glass has come out as the most versatile engineering material of the modern times. The first glass objects made by man were of natural glass such as obsidian and rock crystal. The manufactured glass dates from pre-historic times in the Far East, India and Egypt. But its exact place and date of origin are unknown. With the help of techniques developed in the glass industry, glass of any type and quality can be produced to suit the requirements of different industries. Just to stress the importance of glass in the engineering field of today, few of the recent developments that have taken place in the glass industry are mentioned below :

- (1) A modern Boeing 707 jet plane contains more than 5000 components of glass.
- (2) Fibre glass reinforced with plastics can be used in the construction of furniture, lampshades, bathroom fittings, navy boats, aeroplanes, cars, trucks, etc.
- (3) Glass is the only material strong enough to go upto the bottom of ocean and to maintain its buoyancy. It is, therefore, used in the construction of noses of deep-diving vehicles.
- (4) Glass linings are applied on equipment likely to be affected by chemical corrosion such as valves, pumps, pipes, etc.
- (5) In the construction of modern homes, walls and ceilings of hollow glass blocks can be made. Such construction cuts off the glare. But it admits sunlight and controls sound and heat in a better way.

- (6) In the field of fire-arms, glass is used to form a rifle barrel which is lighter and stronger than the conventional type.
- (7) It will be interesting to note that nowadays it is possible to prepare colour-changing glass. A window with such glass will be transparent during daytime and it will be a source of light at night.
- (8) The body of a guided missile contains thousands of glass items.
- (9) The development and advancement of sciences of astronomy and bacteriology are mainly due to the use of optical glass.
- (10) The mechanical strength of ordinary glass varies from 350 to 700 kg per cm<sup>2</sup>. Due to research in glass industry, it has become possible to produce glass having mechanical strength of about 4200 kg per cm<sup>2</sup>.

### Classification of glass:

Glass is a mixture of a number of metallic silicates, one of which is usually that of an alkali metal. It is amorphous, transparent or translucent. It may also be considered as a solidified super-cooled solution of various metallic silicates having infinite viscosity. For the purpose of classification, glass may be grouped into the following *three* categories:

- (1) Soda-lime glass
- (2) Potash-lime glass
- (3) Potash-lead glass.

One more category of glass may be formed and it may be called common glass. The properties and uses of different categories are mentioned later on in this chapter.

### Composition of glass:

Glass is not a single compound. It is, therefore, very difficult to give any particular chemical formula for it. But with reasonable accuracy, it may generally be expressed as follows:



where a and b are number of molecules,

X = an atom of an alkali metal such as Na, K, etc.

Y = an atom of a bivalent metal such as Ca, Pb, etc.

With this expression, the chemical formulas for *three* groups of glass as classified above, are as follows:

Soda-lime glass:  $\text{Na}_2\text{O}, \text{CaO}, 6\text{SiO}_2$

Potash-lime glass:  $\text{K}_2\text{O}, \text{CaO}, 6\text{SiO}_2$

Potash-lead glass:  $\text{K}_2\text{O}, \text{PbO}, 6\text{SiO}_2$ .

### Properties of glass:

Following are the properties of glass which have made glass popular and useful:

- (1) It absorbs, refracts or transmits light.
- (2) It can take up a high polish.
- (3) It has no definite crystalline structure.
- (4) It has no sharp melting point.
- (5) It is affected by alkalis.
- (6) It is an excellent electrical insulator at elevated temperatures due to the fact that glass can be considered as an ionic liquid. The ions are not easily moved at room temperature because of the high viscosity. But when the temperature rises, the ions are permitted to flow and thus they will sustain an electric current.
- (7) It is available in beautiful colours.
- (8) It behaves more as a solid than most solids in the sense that it is elastic. But when the elastic limit is exceeded, it fractures instead of deforming.
- (9) It is capable of being worked in many ways. It can be blown, drawn or pressed. But it is strange to note that it is difficult to cast in large pieces.
- (10) It is extremely brittle.
- (11) It is not usually affected by air or water.
- (12) It is not easily attacked by ordinary chemical reagents.
- (13) It is possible to alter some of its properties such as fusibility, hardness, refractive power, etc.

- (14) It is possible to obtain glasses with diversified properties. The glasses may be clear, colourless, diffuse and stained.
- (15) It is possible to weld pieces of glass by fusion.
- (16) It is transparent and translucent. The transparency is the most used characteristic of glass and it is due to the absence of free electrons. For the same reason, it also works as a good insulator.
- (17) When it is heated, it becomes soft and soft with the rise in temperature. It is ultimately transformed into a mobile liquid. This liquid, when allowed to cool, passes to all the degrees of viscosity. This property of glass has made its manufacturing process easy. It can also be formed into articles of desired shape. Thus the amorphousness of glass permits it to be blown, drawn from furnaces and continuously worked.
- (18) Due to advancement made in the science of glass production, it is possible to make glass lighter than cork or softer than cotton or stronger than steel. The strength of glass however is considerably affected by foreign inclusions, internal defects and cords or chemically heterogeneous areas.

### **Types of glass:**

The properties and uses of the following types of glass will now be discussed:

- (1) Soda-lime glass
- (2) Potash-lime glass
- (3) Potash-lead glass
- (4) Common glass.

#### **(1) *Soda-lime glass:***

This is also known as *soda-glass* or *soft-glass*. It is mainly a mixture of sodium silicate and calcium silicate.

**Properties :**

- (i) It is available in clean and clear state.
- (ii) It is cheap.
- (iii) It is easily fusible at comparatively low temperatures.
- (iv) It is possible to blow or to weld articles made from this glass with the help of simple sources of heat.

**Uses :**

It is used in the manufacture of glass tubes and other laboratory apparatus, plate glass, window glass, etc.

**(2) Potash-lime glass :**

This is also known as *Bohemian-glass* or *hard-glass*. It is mainly a mixture of potassium silicate and calcium silicate.

**Properties :**

- (i) It fuses at high temperatures.
- (ii) It is not easily affected by water and other solvents.
- (iii) It does not melt so easily.

**Uses :**

This glass is used in the manufacture of glass articles which have to withstand high temperatures such as combustion tubes, etc.

**(3) Potash-lead glass :**

This is also known as *flint glass*. It is mainly a mixture of potassium silicate and lead silicate.

**Properties :**

- (i) It fuses very easily.
- (ii) It is easily attacked by aqueous solutions.
- (iii) It possesses bright lustre and great refractive power.
- (iv) Its specific gravity is about 3 to 3.30.
- (v) It turns black and opaque, if it comes into contact with reducing gases of the furnace during heating.

*Uses:*

It is used in the manufacture of artificial gems, electric bulbs, lenses, prisms, etc.

**(4) Common glass:**

This is also known as *bottle glass*. It is prepared from cheap raw materials. It is mainly a mixture of sodium silicate, calcium silicate and iron silicate.

*Properties:*

- (i) It fuses with difficulty.
- (ii) It is brown, green or yellow in colour.
- (iii) It is easily attacked by acids.

*Uses:*

It is mainly used in the manufacture of medicine bottles.

**Manufacture of glass:**

The procedure adopted in the manufacture of glass may broadly be divided into the following *five* stages:

- (1) Collection of raw materials
- (2) Preparation of batch
- (3) Melting in furnace
- (4) Fabrication
- (5) Annealing.

**(I) Collection of raw materials:**

Depending upon the type of glass to be manufactured, suitable raw materials are collected. Table 12-1 shows the raw materials required for each type of glass.

TABLE 12-1

## RAW MATERIALS FOR EACH TYPE OF GLASS

Sr.No.	Type of glass	Raw materials
1.	Soda-lime glass	Chalk, soda ash and clean sand.
2.	Potash-lime glass	Chalk, potassium carbonate ( $K_2CO_3$ ) and clean sand.
3.	Potash-lead glass	Litharge ( $PbO$ lead monoxide) or lead sesquioxide ( $Pb_2O_3$ ), potassium carbonate and pure sand.
4.	Common glass	Chalk, salt cake ( $Na_2SO_4$ ), coke, ordinary sand, etc.

In addition to raw materials, cullet and decolouriser are also added for each type of glass.

*Cullet* indicates waste glass or pieces of broken glass. They increase the fusibility of glass which is produced and they also reduce the cost.

The raw materials generally contain traces of iron compounds. Ferrous oxide imparts a green colour to glass and ferric oxide imparts a very light yellow tint. To avoid such effects, decolourisers are added. The usual substances used as decolourisers are antimony oxide ( $\text{Sb}_2\text{O}_3$ ), arsenic oxide ( $\text{As}_2\text{O}_3$ ), cobalt oxide ( $\text{CoO}$ ), manganese dioxide ( $\text{MnO}_2$ ) and nickel oxide ( $\text{NiO}$ ).

### (2) *Preparation of batch:*

The raw materials, cullet and decolouriser are finely powdered in grinding machines. These materials are accurately weighed in correct proportions before they are mixed together. The mixing of these materials is carried out in mixing machines until a uniform mixture is obtained. Such a uniform mixture is known as *batch* or frit and it is taken for further process of melting in a furnace.

### (3) *Melting in furnace:*

The batch is melted either in a pot furnace or in a tank furnace. The heating is continued until the evolution of carbon dioxide, oxygen, sulphur dioxide and other gases stops.

#### *Pot furnace:*

In this furnace, pots are adopted as units. A typical glass melting pot is shown in fig. 12-1. A pot is a vessel made of fire-clay. This process resembles crucible steel process. These pots are placed in specially prepared holes in the furnace. The charging and collecting doors are kept projecting outside so that raw materials may be added and molten glass may be taken out conveniently.

The pots are filled with raw materials. The furnace is heated by means of producer gas. When the mass has melted down, it is removed from the pot and it is taken for the next operation of fabrication.

The melting of glass by pot furnace is an intermittent process. It is used to melt small quantities of glass at a time or to prepare special types of glass.

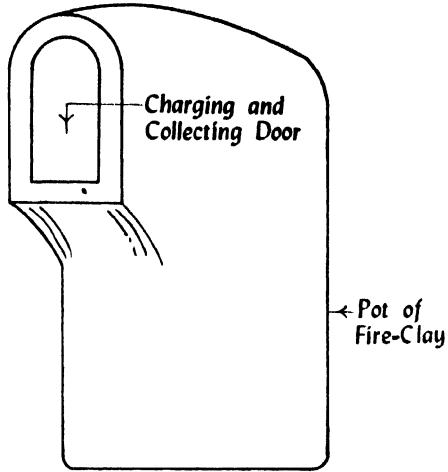

Glass melting pot  
FIG. 12-1

*Tank furnace:*

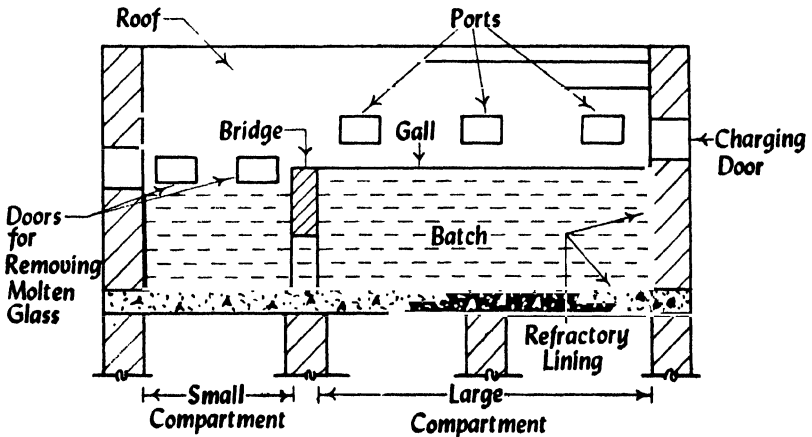

Tank furnace  
FIG. 12-2

This furnace resembles reverberatory furnace adopted for puddling of wrought-iron. Fig. 12-2 shows the section of a tank furnace adopted for melting of glass. It is constructed

with reinforced masonry. The roof is given special shape to deflect the flames of heated gas. Ports are provided for the entry of pre-heated producer gas. Doors are provided for charging and for taking out molten glass. A bridge separates the tank into two unequal compartments. The batch is heated in large compartment and it contains somewhat impure glass. It flows through opening of bridge into small compartment. Gall or floating impurities are collected at the top of large compartment. Refractory lining is provided to the interior surface of tank.

The tank is filled with raw materials. The furnace is heated by allowing producer gas through ports. The charging of raw materials and taking out of molten mass are simultaneous. This is a continuous process and it is adopted to melt large quantities of glass at a time.

#### (4) *Fabrication:*

The molten glass is given suitable shape or form in this stage. It can either be done by hand or by machine. Hand fabrication is adopted for small scale production and machine fabrication is adopted for large scale production. Following are the different ways of fabrication:

- (i) Blowing
- (ii) Casting
- (iii) Drawing
- (iv) Pressing
- (v) Rolling
- (vi) Spinning.

#### (i) *Blowing:*

For this purpose, a blow-pipe is used. Its diameter is about 12 mm and its length is about 180 cm. One end of the blow-pipe is dipped in the molten mass of glass and a lump of about 5 kg is taken out. This lump of glass will then lengthen to some extent by its own weight. The operator then blows vigorously from other end of blow pipe. It can also be done with the help of an air compressor. This

blowing causes the molten mass to assume the shape of a cylinder. It is then heated for few seconds and is blown again. The blowing and heating are continued till the cylinder of required size is formed. It is then placed on an iron plate and it is disconnected from blow pipe. The cylinder is then cut vertically by a diamond. It falls into a thin plate by gravity.

(ii) *Casting:*

The molten glass is poured in moulds and it is allowed to cool down slowly. Large pieces of glass of simple design can be prepared by this method. It is also adopted to prepare mirrors, lenses, etc.

(iii) *Drawing:*

This process consists in simply pulling the molten glass either by hand or by mechanical equipment. An iron bar is dipped sideways in the molten mass of glass. It is lifted up horizontally and in doing so, it catches up a sheet of molten glass. This sheet is then allowed to pass over a large rotating roller. The roller helps the molten glass to spread in the form of a thin sheet.

(iv) *Pressing:*

In this process, the molten glass is pressed into moulds. The pressure may either be applied by hand or by mechanical means. This process is adopted for ornamental articles, hollow glass articles, etc.

(v) *Rolling:*

There are *two* methods of rolling. In one method, the molten mass of glass is passed between heavy iron rollers and flat glass plate of uniform thickness is obtained. In another method, the molten mass of glass is poured on a flat iron casting table and it is then turned flat with the aid of a heavy iron roller.

(vi) *Spinning:*

In this process, the molten glass is spun at high speed to a very fine size. This glass has tensile strength equal to that of mild steel. It does not fade, decay or shrink. It is not

attacked by acids, fire and vermins. It is very soft and flexible. It is used for providing insulation against heat, electricity and sound.

**(5) Annealing:**

Glass articles, after being manufactured, are to be cooled down slowly and gradually. This process of slow and homogeneous cooling of glass articles is known as *annealing of glass*.

Annealing of glass is a very important process. If glass articles are allowed to cool down rapidly, the superficial layer of glass cools down first as glass is a bad conductor of heat. The interior portion remains comparatively hot and it is, therefore, in a state of strain. Hence such glass articles break to pieces under very slight shocks or disturbances.

Following are the *two* methods of annealing:

- (i) Flue treatment
- (ii) Oven treatment.

**(i) Flue treatment:**

In this method, a long flue is provided and it is constructed in such a way that there is gradual decrease in temperature from one end of flue to the other. The red-hot articles of glass are allowed to enter at the hot end of flue and they are slowly moved on travelling bands. They become cool when they reach the cool end of flue. This method is useful for large scale production.

**(ii) Oven treatment:**

In this method, the red-hot glass articles are placed in ovens, in which arrangement is made to control the temperature. After articles are placed in ovens, the temperature is slowly brought down. This method is useful for small scale production.

**Treatment of glass:**

Glass may be given the following treatments:

- (1) Bending
- (2) Cutting
- (3) Opaque making
- (4) Silvering.

**(1) Bending:**

Glass may be bent into desired shape by placing it in ovens in which temperature can be regulated. Glass in the form of rods, sheets or tubes is placed in such ovens and heated. It is then bent when it is suitably heated.

**(2) Cutting:**

Glass is cut in required sizes with the help of diamond or rough glasses or small wheels of hardened steel.

**(3) Opaque making:**

Glass can also be made opaque or impervious to light. It is done by grinding the glass surface with emery. It can also be achieved chemically by the application of hydro-fluoric acid.

**(4) Silvering:**

This process consists in applying a very thin coat of tin on the surface of glass. Silver is deposited on this layer of tin. A suitable paint is then applied to give protection against atmospheric effects.

**Coloured glass:**

To make coloured glass, colouring pigment is added to the raw materials while preparing the batch for its manufacture. The whole mass is heated till it becomes homogeneous.

**TABLE 12-2**  
COLOURING SUBSTANCES FOR GLASS

Sr.No.	Colour	Substances
1.	Blue	Cobalt oxide, Cupric oxide (CuO)
2.	Dark blue or dark brown or dark violet	Cobalt, manganese and iron oxides
3.	Green	Ferroso — ferric oxide ( $\text{Fe}_3\text{O}_4$ ), Chromium sesquioxide ( $\text{Cr}_2\text{O}_3$ )
4.	Red	Caprous oxide ( $\text{Cu}_2\text{O}$ ), Metallic gold
5.	Violet	Manganese dioxide ( $\text{MnO}_2$ )
6.	White opaque	Tin oxide, Calcium phosphorite ( $\text{Ca}_3(\text{PO}_4)_2$ )
7.	Yellow or brown	Antimony trisulphide ( $\text{Sb}_2\text{S}_3$ ), Charcoal, Silver borate, etc.

The colouring pigment may consist of metallic oxides, finely divided metals, carbon, salts of metal, sulphur, etc. Table 12-2 shows different substances which are used to

produce different shades of colour. It may be noted that different quantities of the same substance may also impart different colour to glass.

The coloured glass is used for various purposes such as artificial precious stones, window panels, fancy articles, decorative tiles, etc.

### **Special varieties of glass:**

At present, it is possible to alter the chemical, electrical, mechanical and optical properties of glass by suitably changing the basic composition of the glass. As a matter of fact, glass has emerged as a versatile engineering material which can be tailor-made to meet with the requirements of different industries in the most effective and economic way. Brief descriptions of some of the following important special varieties of glass are given:

- (1) Bullet-proof glass
- (2) Fibre glass
- (3) Foam glass
- (4) Heat-excluding glass
- (5) Perforated glass
- (6) Safety glass
- (7) Shielding glass
- (8) Soluble glass
- (9) Structural glass
- (10) Ultra-violet ray glass
- (11) Wired glass.

#### **(1) *Bullet-proof glass:***

This glass is made of several layers of plate glass and alternate layers consist of vinyl-resin plastic. The outer layers of plate glass are made thinner than the inner layers. Special care is to be taken for heating and cooling of layers during manufacture. The thickness of this type of glass may vary from 15 mm to 75 mm or more. It will not allow bullet to pierce through it.

**(2) Fibre glass:**

The fibre glass is composed of minute glass rods and each glass rod resemble the parent material in all respects. It is soft to the touch and it is flexible in nature. It does not absorb water and it is fire-proof. It can be prepared either in the form of continuous strands just like silk or in the staple form just like wool.

**(3) Foam glass:**

The foam glass is prepared in the form of rectangular blocks. Finely ground glass and carbon are thoroughly mixed and the mixture is then melted in a furnace. At the time of melting, the mixture expands and assumes the form of a black foam. The resulting glass material contains more than 350 million inert air cells per  $m^3$ . The foam glass floats in water and it can be cut like wood. It is fire-proof, rigid and an excellent heat insulator. It can be used as a substitute for cork for use in air-conditioning and refrigeration industries.

**(4) Heat-excluding glass:**

This glass allows light to pass through it. But it eliminates heat. It is used for windows of coaches of higher class in railways, in window panels of important buildings, etc.

**(5) Perforated glass:**

In this type of glass, perforations are made in sheet glass with the help of rollers. The perforations may be made during the manufacture or after the manufacture. It is used for panels in ventilators.

**(6) Safety glass:**

This glass is formed by placing celluloid between two sheets of plate glass and then applying glue to make a single unit. If glass breaks, flying of splinters does not occur.

**(7) Shielding glass:**

This is a special variety of glass and it contains heavy elements like lead oxide ( $PbO$ ), etc. It is used for windows through which high radiation is observed. Depending upon the type of radiation, quality of shielding glass is determined.

**(8) Soluble glass:**

It is prepared by melting quartz sand, grinding and thoroughly mixing it with soda ash, sodium sulphate or potassium carbonate. The melting is carried out in glass tanks at a temperature between 1300°C to 1400°C and it takes about 7 to 10 hours. The resultant glass mass flows out from the furnace and it cools rapidly and breaks up into pieces, known as "*silica lumps*". This glass, under normal conditions, is soluble in water. Soluble glass in the form of silicate lumps is transported in containers and in the form of liquid, it is transported in barrels or glass bottles. It is used for preparing acid-resistant cement.

**(9) Structural glass:**

These are in the form of blocks and they are popularly known as *glass bricks*. These blocks allow light to pass and they can be used as light structural members. They are used for partitions, lantern lights, etc.

**(10) Ultra-violet ray glass:**

This glass transmits effectively ultra-violet rays even though it is not in the direction of the rays of sun. It is widely used in windows of schools, hospitals, etc.

**(11) Wired glass:**

In this type of glass, steel wire mesh is placed in glass during rolling operation. The mesh may have hexagonal or square units. If this glass breaks, pieces of glass are held by wire in position. This glass is also fire-resistant. The wired glass is used for roofs, skylights, etc.

**Glass industry in India:**

The glass industry in India has made rapid progress after independence. The Central Glass and Ceramic Research Institute has been set up by the Govt. of India to guide the glass industry. Optical glass and foam glass are manufactured at the plants set up at the Institute. Optical glass is a strategic material and it is used for making a wide variety of optical instruments. Other important varieties of glass manufactured in India are ophthalmic glass, fibre glass reinforced with plastics, toughened glass, laboratory glass-

wares, etc. In general, all common types of glasses and glass articles are produced in India. However, to compete in the world market and to increase the production, glass industry in India will have to seriously consider various factors such as extensive utilisation of indigenous raw materials, system of supply of standard quality raw materials to the industry, improved methods of production, maintaining and improving the quality of products, co-ordination between research and the industry, etc.

### QUESTIONS

1. Give classification and composition of glass.
2. State the general properties of glass.
3. Mention the properties and uses of various types of glass.
4. State the raw materials required in the manufacture of different types of glass.
5. Describe the process of manufacturing glass.
6. Draw a neat sketch of tank furnace used in the manufacture of glass and explain its working.
7. Describe the various treatments given to glass.
8. How is coloured glass made? State the colouring substances which are used for getting different shades of colour in glass.
9. Write short notes on:
  - (1) Flint glass
  - (2) Annealing of glass
  - (3) Fabrication of glass
  - (4) Wired glass
  - (5) Glass melting pot
  - (6) Safety glass
  - (7) Common glass
  - (8) Silvering
  - (9) Coloured glass
  - (10) Foam glass
  - (11) Bullet-proof glass.

10. State the special varieties of glass and briefly describe them.
11. Explain the importance of glass as an engineering material. Illustrate your answer by giving few of the recent developments in the glass industry.
12. How is soluble glass prepared?
13. Write a critical note about glass industry in India.
14. Differentiate between the following:
  - (1) Soft-glass and hard-glass
  - (2) Flint glass and bottle glass
  - (3) Drawing and pressing
  - (4) Cutting and silvering
  - (5) Foam glass and perforated glass
  - (6) Potash-lime glass and potash-lead glass
  - (7) Pot furnace and tank furnace
  - (8) Flue treatment and oven treatment
  - (9) Shielding glass and structural glass
  - (10) Safety glass and ultra-violet glass
  - (11) Structural glass and soluble glass.
15. Give reasons for the following:
  - (1) In addition to raw materials, cullet and decolourisers are also added for each type of glass.
  - (2) Annealing of glass is a very important process.
  - (3) Glass is used in the construction of noses of deep-diving vehicles.
  - (4) Glass is an excellent electrical insulator at elevated temperatures.
  - (5) The roof of tank furnace is given special slope.
  - (6) The tank furnace is divided into two unequal compartments.
  - (7) The bullet-proof glass will not allow bullet to pierce through it.

# Chapter 13

## PAINTS, VARNISHES AND DISTEMPERS

### **General:**

In this chapter, the final finishing of all surfaces such as walls, ceilings, woodwork, metal work, etc. will be discussed. According to the nature of the surface and the finishing required, the surface should be coated with paint or varnish or distemper, etc. The paints are coatings of fluid materials and they are applied over the surfaces of timber and metals. The varnishes are transparent or nearly transparent solutions of resinous materials and they are applied over the painted surfaces. The distempers are applied over the plastered surfaces. The protective power granted by the application of paints, varnishes and distempers decreases with the passage of time and hence they are to be periodically applied at intervals of about 2 to 5 years.

### **Painting:**

Following are the objects of painting a surface:

- (1) It protects the surface from weathering effects of the atmosphere.
- (2) It prevents decay of wood and corrosion in metal.
- (3) It is used to give good appearance to the surface. Decorative effects may be created by painting and the surface becomes hygienically good, clean, colourful and attractive.

### ***Characteristics of an ideal paint:***

- (1) It should possess a good spreading power, i.e., maximum area of the surface should be covered by minimum quantity of the paint.
- (2) The paint should be fairly cheap and economical.
- (3) The paint should be such that it can be easily and freely applied on the surface.

- (4) The paint should be such that it dries in reasonable time and not too rapidly.
- (5) The paint should be such that its colour is maintained for a long time.
- (6) The paint should form a hard and durable surface.
- (7) The paint should not be affected by weathering actions of the atmosphere.
- (8) The paint should possess attractive and pleasing appearance.
- (9) The surface coated with paint should not show cracks when the paint dries.
- (10) When applied on the surface, the paint should form a thin film of uniform nature.

### ***Ingredients of an oil borne paint:***

An oil paint essentially consists of the following ingredients:

- (1) a base,
- (2) a vehicle or carrier,
- (3) a drier,
- (4) a colouring pigment, and
- (5) a solvent.

#### (1) *Bases:*

A '*base*' is a solid substance in a fine state of division and it forms the bulk of a paint. It determines the character of the paint and imparts durability to the surface which is painted. Table 13-1 gives the list of bases which are commonly used for paints.

#### (2) *Vehicles:*

The vehicles are liquid substances which hold the ingredients of a paint in liquid suspension. They are required mainly for *two* reasons:

- (i) to make it possible to spread the paint evenly on the surface, and

- (11) to provide a binder for the ingredients of a paint so that they may stick or adhere to the surface.

Table 13-2 gives the list of vehicles which are commonly employed in preparing a paint.

**TABLE 13-1**  
**BASES FOR PAINTS**

Sr.No.	Name	Description
1.	White lead	This is a carbonate of lead and it forms the base of lead paints. It possesses good bulk and is the most widely used base. It is dense, permanent and water-proof. It is not suitable for delicate work as lead becomes discoloured when exposed to sulphur vapours. It is most suitable for wood surfaces and not used for iron surfaces as it does not afford protection against rusting.
2.	Red lead	This is an oxide of lead and it forms the base of lead paints. It is quite suitable for painting iron surfaces and for providing a priming coat to wood surfaces. It solidifies in a short time with linseed oil and hence it is used as a drier also.
3.	Oxide of zinc or zinc white	This is an oxide of zinc and it forms the base of all zinc paints. It is smooth, transparent and non-poisonous. It is not discoloured when exposed to sulphur vapours. It has less bulk and hence it is costly. It is less durable and it is difficult to work.
4.	Oxide of iron	This is an oxide of iron and it forms the base of all iron paints. The tint of paint varies from yellowish brown to black. It mixes easily with the vehicle. It is effective in preventing rusting of iron surfaces. It is cheap and durable. It is generally used for priming coat of iron surfaces.
5.	Titanium white	This material possesses intense opacity. It is non-poisonous and provides a thin transparent film. It is used for the receiving coat of an enamel.
6.	Antimony white	This is nearly similar to titanium white.
7.	Aluminium powder	This forms the bulk of aluminium paints. It keeps moisture content of wood surfaces practically the same. It also prevents cracking and warping of wood. It is generally used for a priming coat to new woodwork.
8.	Lithophone	This is a mixture of zinc sulphide and barytes. It is similar in appearance to oxide of zinc. It is cheap and it can easily be applied on the surface. However, when exposed to daylight, it changes colour. Hence it is used for interior work of inferior nature.

**TABLE 13-2**  
**VEHICLES FOR PAINTS**

Sr.No.	Name	Description
1.	Linseed oil	This is the most common material used as vehicle of a paint. It is extracted from flax seeds. Linseed oil prepared from fine full-grown ripe seeds is clear, transparent, pale, sweet to the taste and practically odourless. It is used in various grades.
	(a) Raw linseed oil	Raw linseed oil is thin and pale. It requires more time for drying and is used for interior work of delicate nature.
	(b) Boiled linseed oil	This oil is thicker and darkly coloured than raw oil. It dries quickly. It is prepared by adding some quantity of drier such as litharge or red lead to the raw oil. It cannot be used for interior delicate work. It is used for exterior surfaces.
	(c) Pale boiled linseed oil	This is similar to boiled linseed oil except that it does not possess a dark colour. It is more suitable for painting plastered surfaces.
	(d) Double boiled linseed oil	This oil dries very quickly and is suitable for external work. It however requires a thinning agent like turpentine.
	(e) Stand oil	Formerly this oil was prepared by exposing raw linseed oil to sun till it thickened like honey. At present, heat treatment is used for this purpose. This oil dries slowly and provides a durable, clear and shining finish.
2.	Tung oil	This oil is far superior to linseed oil and is used for preparing paints of superior quality.
3.	Poppy oil	This oil is prepared from poppy seeds. It dries slowly. But its colours last long. It is used for making paints of delicate colours.
4.	Nut oil	This oil is extracted from ordinary walnuts. It is nearly colourless and dries rapidly. It does not provide a durable finish and is used for ordinary work.

### (3) *Driers:*

These substances accelerate the process of drying. A drier absorbs oxygen from the air and transfers it to the linseed oil, which in turn, gets hardened. Driers have a tendency to injure the colour of a paint and to destroy the elasticity of a paint. They are, therefore, not generally used for the final or finishing coat of the paint. Various patented

driers are available in the market. They may be either in the form of soluble driers or paste driers. The former driers are compounds of metals such as cobalt, lead, manganese, etc. dissolved in linseed oil or some other volatile liquid. The latter driers are compounds of the same metal. But they are mixed with inert fillers such as barytes, whiting, etc. and then ground in linseed oil. The inert fillers serve as adulterants and the weight of inert filler in a paint should not exceed one-fourth the weight of base. They are used for the following purposes:

- (i) to bring down the cost of paint;
- (ii) to improve the durability of paint;
- (iii) to modify the weight of paint; and
- (iv) to prevent shrinkage and cracking.

Litharge, red lead and sulphate of manganese can also be used as driers. Litharge is the most commonly used drier. Red lead is less effective than litharge and it is to be used when its addition does not interfere with the tint of the paint. Sulphate of manganese is used with zinc paints so as to eliminate the risk of discolouration of a lead drier. Great care is required in mixing sulphate of manganese. Otherwise spots will be formed on the painted surface.

#### (4) *Colouring pigments:*

When it is desired to have a different colour than the base of a paint, a colouring pigment is to be added. Following are *five divisions* of colouring pigments:

- (i) Natural earth colours such as ochres, umbers, iron oxides, etc.
- (ii) Calcined colours such as lamp black, Indian red, carbon black, red lead, etc.
- (iii) Precipitates such as Prussian blue, chrome green, chrome yellow, etc.
- (iv) Lakes prepared by discolouring barytes or china clay with the help of suitable dyes.
- (v) Metal powders such as aluminium powder, bronze powder, copper powder, zinc powder, etc.

Table 13-3 shows the colouring pigments which are used to create a particular tint of a paint.

**TABLE 13-3**  
COLOURING PIGMENTS FOR PAINTS

Tint of paint	Pigments
Black	Graphite, lamp black, ivory black, vegetable black.
Blue	Indigo, Prussian blue.
Brown	Burnt umber, raw umber.
Green	Chrome green, copper sulphate.
Red	Carminc, red lead, vermilion red.
Yellow	Chrome yellow, raw sienna, yellow ochre, zinc chrome.

(5) *Solvents:*

The function of a solvent is to make the paint thin so that it can be easily applied on the surface. It also helps the paint in penetrating through the porous surfaces. The most commonly used solvent is the spirit of turpentine. Other solvents containing some part of spirit of turpentine are available. But they are inferior to pure spirit of turpentine. The purity of spirit of turpentine can be tested by evaporation. Pure spirit of turpentine does not leave any residue on evaporation. Turpentine is greatly affected by weather and hence, for exterior works, it should be taken in minimum quantity to make the paint workable on the surface.

***Types of paints:***

The brief descriptions of different types of paints are given below.

(1) *Aluminium paint:*

Very finely ground aluminium is suspended in either quick-drying spirit varnish or slow-drying oil varnish as per requirement. The spirit or oil evaporates and a thin metallic

film of aluminium is formed on the surface. *Advantages* of an aluminium paint are as follows:

- (i) It is visible in darkness.
- (ii) It resists heat to a certain degree.
- (iii) Surfaces of iron and steel are better protected from corrosion by this paint than any other paint.
- (iv) It possesses a high covering capacity. A litre of paint can cover an area of about 200 m<sup>2</sup>.
- (v) It gives good appearance to the surface.
- (vi) It is impervious to moisture.
- (vii) It possesses high electrical resistance.

The aluminium paint is widely used for painting gas tanks, hot water pipes, marine piers, oil storage tanks, radiators, etc.

(2) *Anticorrosive paint* :

This paint essentially consists of oil and a strong drier. A pigment such as chromium oxide, lead, red lead or zinc chrome is taken and after mixing it with some quantity of very fine sand, it is added to the paint. *Advantages* of an anticorrosive paint are as follows:

- (i) It is cheap.
- (ii) It lasts for a long duration.
- (iii) The appearance of the paint is black.

(3) *Asbestos paint* :

This is a peculiar type of paint and it is applied on the surfaces which are exposed to acidic gases and steam.

(4) *Bituminous paint* :

This paint is prepared by dissolving asphalt or mineral pitches or vegetable bitumen in any type of oil or petroleum. A variety of bituminous paints is available. The paint presents a black appearance and it is used for painting ironwork under water.

(5) *Cellulose paint* :

This paint is prepared from nitro-cotton, celluloid sheets, photographic films, etc. An ordinary paint hardens by oxidation. A cellulose paint hardens by evaporation of thinning agent. It thus hardens quickly. It is a little more costly, but it presents a flexible, hard and smooth surface. Also, the surface painted with cellulose paint can be washed and easily cleaned. The cellulose paint is not affected by contact with hot water and the surface can stand extreme degrees of cold and heat.

(6) *Cement paint* :

This paint consists of white cement, pigment, accelerator and other additives. It is available in dry powder form. Cement paint is available in variety of shades and it exhibits excellent decorative appearance. It is water-proof and durable. It proves to be useful for surfaces which are damp at the time of painting or are likely to become damp after painting. For external finish, on cement-plastered walls, it is mixed with water immediately before its application. It is desirable to provide cement paint on rough surface rather than on smooth surface because its adhesion power is poor on smoothly finished surface.

For painting surfaces like corrugated iron sheets, etc., cement paint is mixed with boiled linseed oil. The mixture is constantly stirred during use.

(7) *Colloidal paint* :

No inert material is mixed in this type of paint. It requires more time to settle and in the process of settlement, it penetrates through the surface. It may be used for interior as well as exterior walls.

(8) *Emulsion paint* :

A variety of emulsion paints is available. It contains binding materials such as polyvinyl acetate, synthetic resins, etc. This paint is easy to apply and it dries quickly in about  $1\frac{1}{2}$  to 2 hours. The colour of the paint is retained for a long period and the surface of paint is tough and it can be cleaned

by washing with water. There is absence of odour and the paint possesses excellent alkali resistance.

The application of emulsion paint can be carried out either by brush or spray gun. For long service life, it is recommended to apply two coats of emulsion paint. For rough cement plastered surface, a thin coat of cement paint may first be applied to smoothen the surface. It is necessary to have a sound surface to receive the emulsion paint.

(9) *Enamel paint:*

This paint is available in different colours. It contains white lead or zinc white, oil, petroleum spirit and resinous matter. It dries slowly and forms a hard and durable surface. The surface provided with this paint is not affected by acids, alkalies, fumes of gas, hot and cold water, steam, etc. It can be used for both internal and external walls. In order to improve the appearance, it is desirable to apply a coat of titanium white in pale linseed oil before the coat of enamel paint.

(10) *Graphite paint:*

The paint presents a black colour and it is applied on iron surfaces which come in contact with ammonia, chlorine, sulphur gases, etc. It is also used in mines and underground railways.

(11) *Inodorous paint:*

No turpentine is used in this paint, but white lead or zinc white is mixed with methylated spirit. White lead or zinc white is well ground in oil. Shellac with some quantity of linseed oil and castor oil is dissolved in methylated spirit. The paint is not durable, but it dries quickly. The methylated spirit evaporates and a film of shellac remains on the surface.

(12) *Luminous paint:*

This paint contains calcium sulphide with varnish. The surface on which luminous paint is applied shines like radium dials of watches after the source of light has been cut off. The paint should be applied on surfaces which are free from corrosion or any other lead paint.

(13) *Oil paint:*

This is the ordinary paint and it is generally applied in three coats of varying composition. They are respectively termed as primes, undercoats and finishing coats. This paint is cheap and easy to apply and it possesses good opacity and low gloss.

It should be remembered that oil paint should not be applied during humid and damp weather. The presence of dampness on wall surface also considerably affects the life of oil paint coating. It is advisable to redecorate the surfaces finished with oil paint with a coating of fresh oil paint only. The layer of old oil paint serves as a foundation for fresh paint.

(14) *Plastic paint:*

This paint contains the necessary variety of plastics and it is available in the market under different trade names. The application of plastic paint can be done either by brush painting or spray painting. This paint possesses pleasing appearance and it is attractive in colour. This paint is widely used for show rooms, auditoriums, etc.

(15) *Silicate paint:*

This paint is prepared by mixing calcined and finely ground silica with resinous substances. The paint when dried forms a hard surface and it is durable. It can stand extreme heat and it adheres firmly to brickwork also. It is not affected by alkalis. No chemical action takes place on metals by this paint. Drier used with this paint should be of a special silicate drier type.

Silicate paint can directly be applied on brick, plaster or concrete surfaces. These surfaces should be made wet before the paint is applied. Two or three coats of silicate paint are recommended and it is not necessary to have a priming coat. The tool which is used to apply silicate paint should be immediately cleaned with water after use. The surfaces should not be painted with silicate paint in hot weather.

(16) *Synthetic rubber paint:*

This paint is prepared from resins. It has the following *advantages:*

- (i) It offers good resistance to water and is not affected by heavy rains.
- (ii) It dries quickly.
- (iii) A uniform colour is maintained when this paint is applied on the surface.
- (iv) It is little affected by weather and sunlight.
- (v) It can be applied on surfaces which may not be completely dry, e.g., fresh concrete.
- (vi) It is moderate in cost and covers a sizeable area.
- (vii) It is easy to apply on the surface.
- (viii) It possesses excellent chemical resisting property.

### ***Notes for guidance in the process of painting:***

Some of the important points to be noted before we take up the discussion of process of painting are mentioned below:

#### (1) *Brushes:*

It is necessary to have good brushes for painting. The brushes should be composed of bristles and not of horse hairs. Bristle brushes are elastic and possess good paint-holding capacity. Bristles are split at ends and in this respect, they can be distinguished from horse hairs. It is preferable to use a round brush in painting. New brushes should be soaked in water upto level of bristles for a period of about two hours and then they should be allowed to dry for a period of about one hour. During painting, the brush should be immersed in paint upto about one-third length of the bristle and the excess paint in the brush is removed by gently pressing the bristles against the inside surface of the pot. After the work is over, the brushes should be cleaned with kerosene oil.

#### (2) *Paints:*

Ready mixed paints of different make and various brand are available in the market. They are available in different tints and can be applied in the same form as received. Ready mixed paints are normally expensive. The procedure for preparing paint from stiff paint is as follows:

- (i) Sufficient stiff paint is taken in a pot. The remaining stiff paint is to be covered or left with a layer of linseed oil.
- (ii) Linseed oil which may either be raw or boiled or pale is then mixed with stiff paint by a stick.
- (iii) The other ingredients of paint are then added.
- (iv) If a colour is required, suitable pigment is added and thoroughly mixed.
- (v) A second pot is taken and it is covered with a canvass which is tied tightly.
- (vi) The mixed paint is then allowed to pass through the canvass of second pot. Brushes may be used for this purpose.
- (vii) The paint is then ready for use. The mixed paint may be prevented from drying by maintaining a thin film of linseed oil or of water at top.

### (3) *Knotting*:

The term *knotting* is used to indicate the covering or killing of all knots in woodwork with a substance through which the resin cannot exude or come out. There are *three* methods of knotting as mentioned below:

(i) Ordinary or size knotting: This is applied in two coats. For the first coat, red lead ground in water and mixed with strong gluc size is used in hot condition. This coat dries in about ten minutes and then second coat is applied. The second coat consists of red lead ground in oil and it is thinned by boiled oil and turpentine.

(ii) Patent knotting: This is applied in two coats. For both the coats, varnish prepared by dissolving shellac in methylated spirits of wine is used.

(iii) Lime knotting: The knot is covered by hot lime and it is left for 24 hours. The surface is then scraped off and then ordinary knotting is carried out.

### (4) *Stopping*:

The term *stopping* is used to indicate the rubbing down of the surface after the first coat of paint is applied. The

rubbing is done by means of pumice-stone or glasspaper or both. Before rubbing is commenced, the holes, cracks, etc. on the surface are filled with ordinary putty made from whiting and linseed oil. Putty becomes hard when it dries. The term hard stopping is used when instead of ordinary putty, an admixture of one-third white lead and two-third ordinary putty, is filled in holes, cracks, etc. It is adopted for superior work.

(5) *Coats:*

The paint is usually applied in three or four coats. The first coat is known as priming coat, the second one as under coat and the remaining as finishing coats.

Priming coat creates a layer or film which provides adhesion of the paint with the surface. It also protects the surface from weathering actions. Suitable material for priming coat should be used, depending on the nature of surface to be painted.

Undercoat serves to provide foundation or support to the finishing coat. The surface is made even and all irregularities of the surface are removed by this coat.

Finishing coat or coats are then applied as per requirements.

(6) *Spray painting:*

Instead of ordinary brushes, a spraying pistol may be used for painting work. The pistol works under compressed air and the paint thrown through the pistol on the surface forms a thin uniform film or layer of paint on the surface. Spray painting is superior to painting by brushes. Following are the *advantages* of spray painting:

- (i) The speed of work increases considerably.
- (ii) An experienced painter can create artistic patterns or designs on the surface by spraying paints of different shades.
- (iii) It is found to be economical in material and labour. Two coats of spray would suffice whereas ordinary brush painting would require three or four coats.

- (iv) The mechanical equipment is such that the paint remains always in a state of motion. This ensures uniform mixing of ingredients of the paint.

### ***Painting on different surfaces:***

The process of painting depends on the nature of the surface to be painted. A brief description of painting on each of the various surfaces is given below:

#### ***(1) New woodwork:***

Normally four coats of paint are required for new woodwork. The process of painting is carried out as follows:

(i) The surface of woodwork is prepared to receive the paint. For satisfactory working, it is necessary that the woodwork is sufficiently seasoned and it does not contain more than 15 per cent moisture at the time of painting. The surface of woodwork is thoroughly cleaned and the heads of nails are punched to a depth of 3 mm below the surface.

(ii) The surface of the woodwork is then knotted.

(iii) The priming coat is then applied on the surface of new woodwork. Generally the priming coat is applied before the woodwork is placed in position.

(iv) The process of stopping is then carried out.

(v) The subsequent coats of paint, namely, under coats and finishing coats, are then applied on the surface. Extreme care should be taken to see that the finishing coat presents smooth and even surface and that no brush marks are seen on the finished work.

#### ***(2) Repainting old woodwork:***

If the paint on the old woodwork has cracked or has developed blisters, it is to be removed. If the surface has become greasy, it should be cleaned by rubbing down sandpaper or fine pumice stone. Old paint can also be removed by applying any one of the following three paint solvents:

(i) A solution containing 200 gm of caustic soda to a litre of water is prepared and used to wash the surface. The paint dissolves and the surface becomes clean.

(ii) A mixture consisting of one part of soft soap and two parts of potash is prepared and one part of quicklime is then added afterwards. This mixture is applied on the surface in a hot state and allowed to stay for about 24 hours. The surface is then washed with hot water.

(iii) A mixture consisting of equal parts of washing soda and quicklime is brought to a paste form by adding required quantity of water. It is applied on the surface and kept for about an hour. The surface is then washed with water.

After removing old paint from the surface, the woodwork is painted as in case of painting on new woodwork.

(3) *New ironwork and steelwork :*

The surface of iron or steel to receive the paint should be free from rust, grease, dirt, etc. Suitable equipment such as wirebrushes, scrapers, etc. are used to remove all loose scales, marks, etc. from the surface. Water with caustic soda or lime is used to remove grease. The cleaned surface is provided with a film of phosphoric acid. This film protects the surface from rust and it also facilitates the adhesion of paint. The coats of paint are then applied. Paint suitable to iron and steel surfaces should be selected for each coat. The finishing coat should present a smooth finish and precaution should be taken to avoid the presence of brush marks on the final painted surface.

(4) *Repainting old ironwork and steelwork :*

The old surface should be thoroughly cleaned by the application of soapwater and if grease is present, it should be removed by washing the surface with lime and water. If it is necessary to remove old paint, the surface should be burnt, usually by a blow lamp and then old paint should be scraped off or dissolved and removed by using any paint solvent. After the surface is thus prepared, painting is carried out as in case of new ironwork or steelwork.

(5) *Galvanised ironwork :*

As the paint will not adhere to the surface of galvanised ironwork, some treatment is to be given to the surface before a priming coat is applied. It is a general rule not to paint the galvanised ironwork until it has been exposed to weather

for a period of one year or so. However, if it is necessary to paint new galvanised ironwork, any one of the following two solutions is applied on the surface:

- (i) A solution containing 40 gm of copper acetate to a litre of water.
- (ii) A solution containing 13 gm each of muriatic acid, copper chloride, copper nitrate and sel-ammoniac to a litre of soft water. This much quantity of solution will cover an area of about 250 to 300 m<sup>2</sup>.

The solution is taken in a glass vessel or earthenware vessel. This will prevent the precipitation of copper salts. When the solution is applied on the galvanised ironwork, the surface is turned black and after a period of about 12 hours, the coat of paint may be applied on the surface.

Alternatively, a wash of washing soda or zinc sulphate may be given on the surface and when it dries, a priming coat of red lead mixed with linseed oil and turpentine may be applied on the surface. When priming coat dries, a suitable paint may be applied on the surface.

#### (6) *Metals:*

The surface of the metal to be painted should be clean and free from dirt, grease, etc. It should be such as to provide key for the paint. Depending upon the nature of metal, suitable paint is selected. For instances, the priming coat for aluminium surface should be of zinc chromate and that for zinc surface, it should be of zinc oxide.

#### (7) *Plastered surfaces:*

For successful application of paint on cement plastered surfaces, the following factors should be carefully considered:

- (i) There is considerable amount of moisture in newly constructed wall with cement plaster. It is necessary to allow the moisture content to escape. The actual time required for drying of wall surface will depend on atmospheric conditions and ventilation. But it usually requires about 3 to 6 months for the surface to be ready to receive paint. Artificial heating may in some cases be employed in combination with ventilation.

(ii) Cement plaster is alkaline in nature because lime is liberated during the hydration of cement. Hence oil based paints and distempers are liable for alkali attack, especially in presence of moisture. Hence coats of alkali resistant primer paints should be applied or paints not containing any oil should be used.

(iii) Defects in cement plastered surfaces develop due to various reasons. Such defects should be removed and the surface should be prepared to receive the paint.

(iv) Spots showing efflorescence should be brushed off and the surface should be watched for few days. If spots of efflorescence develop again, the process of brushing off should be repeated. It is desirable to postpone painting till such spots cease to appear.

(v) If there are chances for the discolouration of the painted surface, it is necessary to clean the surface and to sterilise it with an antiseptic wash. The organisms responsible for discolouration are algae, mould, lichen, etc. They may be black, green, purple or red in colour. The conditions favourable for their easy and free growth are dampness and high humidity.

With the above remarks in view, the usual paints recommended for cement plastered surfaces are cement paints, emulsion paints, oil paints, silicate paints, etc.

(8) *Concrete surfaces:*

Cement paint is used to paint concrete surfaces. The paint is available in a powder form and it is dissolved in water to a workable consistency. The paint thus prepared should be consumed within 2 to 3 hours. Two coats at an interval of 24 hours are just enough. Water should be sprayed at intervals to provide curing to the painted surface.

(9) *Floor surfaces:*

Enamels are used for painting floor surfaces. The selected enamel should be strong enough to resist abrasion, moisture and alkali action. It should also be of shining nature and quick drying type.

**Defects in painting:**

Following are the usual defects which are found in the painting work:

(1) *Blistings*: This defect is caused by the water vapour which is trapped behind the painted surface. The formation of bubbles under the film of paint occurs in this defect.

(2) *Bloom*: In this defect, the formation of dull patches occurs on the finished polished surface. It is due to defect in paint or bad ventilation.

(3) *Fading*: The gradual loss of colour is known as fading and it is mainly due to the effect of sunlight on pigments of paint.

(4) *Flaking*: A small portion of the painted surface is sometimes seen loose. It is known as flaking and is due to poor adhesion.

(5) *Flashing*: Sometimes glossy patches are seen on the painted surface. This is known as flashing and it is mainly due to poor workmanship, cheap paint or weather actions.

(6) *Grinning*: When the final coat of paint has not sufficient opacity, the background is clearly seen. This is known as grinning.

(7) *Running*: The paint runs back and leaves small areas of surface uncovered. This defect occurs when the surface to be painted is too smooth.

(8) *Sagging*: When a vertical or inclined surface is too thickly painted, the defect of sagging occurs.

(9) *Saponification*: The formation of soap patches on the painted surface is termed as saponification and it is due to chemical action of alkalies.

(10) *Wrinkling*: When a horizontal surface is too thickly painted, the defect of wrinkling becomes prominent.

**Varnishing:**

The term varnish is used to indicate the solution of resins or resinous substances prepared either in alcohol, oil or turpentine.

Following are the *objects* of varnishing a surface:

- (1) It brightens the appearance of the grain in wood.
- (2) It renders brilliancy to the painted surface.
- (3) It protects painted surface from atmospheric actions.

***Characteristics of an ideal varnish:***

- (1) It should render the surface glossy.
- (2) It should dry rapidly and present a finished surface which is uniform in nature and pleasing in appearance.
- (3) The colour of varnish should not fade away when the surface is exposed to atmospheric actions.
- (4) The protecting film developed by varnish should be tough, hard and durable.
- (5) It should not shrink or show cracks after drying.

***Ingredients of a varnish:***

Following are the ingredients of a varnish:

- (1) Resins or resinous substances
  - (2) Driers
  - (3) Solvents.
- (1) *Resins or resinous substances:*

The commonly used resins are copal, lac or shellac and rosin. Copal is a hard substance and is available from the earth at places where pine trees existed in past. It is available in variety of forms. Lac or shellac is obtained by exudation of some types of insects in India. Rosin is obtained from pine trees. Other resins are amber, mastic, gum dammar, etc.

- (2) *Driers:*

The function of a drier in varnish is to accelerate the process of drying. Common driers used in varnishes are litharge, white copper and lead acetate.

- (3) *Solvents:*

Depending upon the nature of resin, the type of solvent is decided. Table 13-4 gives solvents for different resins.

**TABLE 13-4**  
**SOLVENTS FOR RESINS**

Sr.No.	Solvent	Resins
1.	Boiled linseed oil	Amber, Copal.
2.	Methylated spirits of wine	Lac or shellac.
3.	Turpentine	Mastic, Gum dammar, Rosin.
4.	Wood naphtha	Cheap varieties of resins.

### ***Types of varnishes:***

Depending upon the solvent, varnishes are classified into *four* categories:

- (1) Oil varnishes
- (2) Spirit varnishes
- (3) Turpentine varnishes
- (4) Water varnishes.

#### ***(1) Oil varnishes:***

Linseed oil is used as solvent in this type of varnish. Hard resins such as amber and copal are dissolved in linseed oil and if the varnish is not workable, a small quantity of turpentine is added. Oil varnishes dry slowly. But they form hard and durable surface.

#### ***(2) Spirit varnishes:***

Methylated spirits of wine are used as solvent in this type of varnish. Resins are of soft variety such as lac or shellac. Spirit varnishes dry quickly. But they are not durable and are easily affected by weathering actions. They are generally used for furniture. French polish is a variety of this class of varnish and the desired colouring tinge can be obtained by addition of suitable colouring pigment. French polish is one of the finest finish for ornamental furniture prepared from superior quality of wood.

#### ***(3) Turpentine varnishes:***

Turpentine is used as solvent in this type of varnish. Resins adopted are of soft variety such as gum dammar, mastic and rosin. These varnishes dry quickly and possess light colours. They are not durable and tough as oil varnishes.

**(4) Water varnishes:**

Shellac is dissolved in hot water and enough quantity of either ammonia or borax or potash or soda is added such that shellac is dissolved. These varnishes are used for varnishing maps, pictures, etc.

**Process of varnishing:**

The application of varnish on woodwork is carried out in the following way:

(1) *Preparation of surface:* The woodwork is thoroughly rubbed down by means of sandpaper or pumice stone. The surface is then made smooth and clean.

(2) *Knotting:* The process of knotting is then carried out as in case of painting.

(3) *Stopping:* The surface of woodwork is then stopped. This is done by means of hot weak glue size. It will fill up the pores on the surface. One kg of glue will form about 10 litres of glue size. Alternatively, boiled linseed oil can be applied in two coats. When the surface becomes dry, it should be once again rubbed down with sandpaper.

(4) *Coats of varnish:* The varnish is then applied on the surface in thin coats. The next coat is applied after the previous one has thoroughly dried up. The varnishing should not be done with ordinary paint brushes. But fine haired varnishing brushes should be used.

**Distemperring:**

The main object of applying distemper to plastered surfaces is to create a smooth surface. Distempers are available in the market under different trade names. They are cheaper than paints and varnishes and they present a neat appearance. They are available in a variety of colours.

**Properties of distempers:**

Following are the properties of distempers:

- (1) On drying, the film of distemper shrinks. Hence it leads to cracking and flaking, if the surface to receive distemper is weak.
- (2) The coatings of distemper are usually thick and they are more brittle than other types of water paints.

- (3) The film developed by distemper is porous in character and it allows water vapour to pass through it. Hence it permits new walls to dry out without damaging the distemper film.
- (4) They are generally light in colour and they provide a good reflective coating.
- (5) They are less durable than oil paints.
- (6) They are treated as water paints and they are easy to apply.
- (7) They can be applied on brickwork, cement plastered surface, lime plastered surface, insulating boards, etc.
- (8) They exhibit poor workability.
- (9) They prove to be unsatisfactory in damp locations such as kitchen, bathroom, etc.

### ***Ingredients of a distemper:***

A distemper is composed of base, carrier, colouring pigments and size. For base, whiting or chalk is used and for carrier, water is used. Thus it is more or less a paint in which whiting or chalk is used as base instead of white lead and water is used as carrier instead of linsced oil.

Distempers are available in powder form or paste form. They are to be mixed with hot water before use. Oil-bound distempers are a variety of an oil-paint in which the drying oil is so treated that it mixes with water. The emulsifying agent which is commonly used is glue or casein. As the water dries, oil makes a hard surface which is washable. It should be remembered that most of the manufacturers of ready made distempers supply complete directions for use of their products. These directions are to be strictly followed to achieve good results.

### ***Process of distemping:***

The application of distemper is carried out in the following way:

#### ***(1) Preparation of surface:***

The surface to receive the distemper is thoroughly rubbed and cleaned. The important facts to be kept in mind are:

- (i) New plastered surfaces should be kept exposed for a period of two months or so to dry out before distemper is applied on them. The presence of dampness on surface results in failure of distemper coating.
- (ii) The surface to receive distemper should be free from any efflorescence patches. These are to be wiped out by clean cloth.
- (iii) Irregularities such as cracks, holes, etc. of the surface are to be filled by lime putty or gypsum and allowed to become hard before distemper is applied on the surface.
- (iv) If distemper is to be applied on existing distempered surfaces, old distemper should be removed by profuse watering.

(2) *Priming coat:*

After preparing the surface to receive the coats of distemper, a priming coat is applied and it is allowed to become dry. For ready made distempers, the priming coat should be composed of materials as recommended by the makers of distempers. For local made distempers, milk is used for priming coat. One litre of milk will cover about 10 m<sup>2</sup> of the surface.

(3) *Coats of distemper:*

The first coat of distemper is then applied on the surface. It should be of a light tint and applied with great care. The second coat of distemper is applied after the first coat has dried and become hard. Following facts are to be remembered:

- (i) Distemping should be done in dry weather to achieve better results.
- (ii) Oil-bound distemper or washable distemper adheres well to oil-painted walls, wood, corrugated iron, etc. But a priming coat of pure milk should be applied before distemping is done on such surfaces.
- (iii) The application of distemper by a spraying pistol is superior to that by brushes. Spraying affords smooth and durable film of distemper.

**Wall paper:**

The term wall paper is used to indicate a roll paper material with a printed pattern. The material is pasted to the wall or ceiling surfaces and its application thus develops decorative finishing of interior walls.

Wall paper is available in a great variety of patterns and colours. Varnished wall paper can be polished after hanging to develop the effect of veneer-panelled wall. Certain types of wall paper are washable and they may be painted with oil paints. Wall paper with sound-absorbing properties is also available.

**Whitewashing:**

Fresh lime is slaked at site of work and is mixed thoroughly with sufficient quantity of water in a tub. It is then screened through a clean cloth. Clean gum dissolved in hot water is then added at the rate of 2 kg per m<sup>3</sup> of lime. Rice may be used in place of gum.

The surface to be whitewashed should be cleaned before the work is started. For whitewashing walls which are whitewashed before, the old loose whitewash is to be first removed and repairing to plaster is carried out, if necessary.

The whitewash is applied with jute brush and the brush is so worked that a surface with uniform colour is obtained. Three coats are generally applied, each after the previous coat has completely dried.

**Colourwashing:**

This is prepared by adding the colouring pigment to the screened whitewash. It should be seen that colouring pigment is not affected by the presence of lime. Ordinarily yellow earth is popular for colourwashing. Generally, the walls are colourwashed and ceilings are whitewashed. The mixture is to be kept constantly stirred during use.

The colourwash is applied in the same fashion as the whitewash. A satisfactory work does not give out powder when the finished surface is rubbed with the fingers.

**QUESTIONS**

1. Mention the objects of painting and point out the characteristics of an ideal paint.
2. What are the ingredients of an oil borne paint? Describe briefly each of them.
3. Enumerate the different types of paints.
4. Discuss the important points to be noted before the process of painting is started.
5. Give a brief description of the process of painting on different surfaces.
6. Mention the objects of varnishing and point out the characteristics of an ideal varnish.
7. Write short notes on the following:
  - (i) Colouring pigments for an oil paint
  - (ii) Aluminium paint
  - (iii) Enamel paint
  - (iv) Synthetic rubber paint
  - (v) Cellulose paint
  - (vi) Cement paint
  - (vii) Emulsion paint
  - (viii) Silicate paint
  - (ix) Inodorous paint
  - (x) Anticorrosive paint
  - (xi) Vehicles for paints
  - (xii) Plastic paint
  - (xiii) Wall paper.
8. What are the ingredients of a varnish? Describe briefly each of them.
9. Mention the different types of varnishes and describe the process of varnishing on woodwork.
10. Mention the object of distemping and enumerate its ingredients. How is it applied?
11. Mention the usual defects which are found in the painting work.
12. What are the factors to be considered for successful application of paint on cement plastered surfaces?
13. Enumerate the properties of distempers.

14. Write explanatory notes on the following:

- (1) Brushes for painting
- (2) Spray painting
- (3) Painting on galvanised ironwork
- (4) Whitewashing and colourwashing
- (5) Repainting old woodwork
- (6) Repainting old ironwork and steelwork
- (7) Painting on new woodwork
- (8) Painting on metals
- (9) Painting on plastered surfaces
- (10) Solvents for resins
- (11) Bases for paints
- (12) Colouring pigments for paints.

15. Differentiate between the following:

- (1) Base and vehicle
- (2) Ordinary knotting and lime knotting
- (3) Blistering and bloom
- (4) Sagging and wrinkling
- (5) Varnish and distemper
- (6) Priming coat and finishing coat
- (7) Grinning and running
- (8) Spirit varnishes and water varnishes
- (9) White lead and red lead
- (10) Raw linseed oil and boiled linseed oil
- (11) Poppy oil and nut oil
- (12) Emulsion paint and enamel paint
- (13) Driers and inert fillers.

16. Give reasons for the following:

- (1) Driers are not generally used for the final coat of the paint.
- (2) The brushes should be composed of bristles and not of horse hairs.
- (3) New plastered surfaces should be kept exposed for a period of two months or so.
- (4) It is desirable to provide cement paint on rough surface.
- (5) Spray painting is superior to painting by brushes.
- (6) Cement plaster is alkaline in nature.

- (7) The application of distemper permits new walls to dry out without damaging the distemper film.
- (8) The application of distemper by a spraying pistol is superior to that by brushes.
- (9) Cellulose paint hardens quickly.
- (10) It is desirable to apply a coat of titanium white in pale linseed oil before the coat of enamel paint.
- (11) Oil paint should not be applied during humid and damp weather.
- (12) A film of phosphoric acid is provided on the cleaned surface of new ironwork.
- (13) Inert fillers are used in the preparation of paints.
- (14) For exterior works, turpentine should be taken in minimum quantity.
- (15) White lead is not used for painting iron surfaces.
- (16) Red lead is used as a drier also.

# Chapter 14

## PLASTICS

### **Brief history:**

Plastic is one of the recent engineering materials which have appeared in the market all over the world. Some varieties of naturally occurring thermo-plastics were known to Egyptians and Romans who extracted and used these plastics for various purposes. A number of scientists carried out experiments for plastics and as a result of long research, the birth of plastic industry took place in the nineteenth century.

The developments of plastic industry may broadly be grouped into following *three* stages:

- (1) The aim of first stage of development was mainly to imitate or copy the natural plastics. The main contribution during this phase was by a Scottish chemist—Alexander Parkes. He prepared a hard material in 1865 by mixing camphor and alcohol with nitro-cellulose. This material was known as *Parkesite* and it was used for gear wheels, door knobs, etc.
- (2) The second stage is comprised in first twenty years or so of this century. During this stage, the work done previously in plastic industry was scientifically scrutinised and this stage laid the foundation for further scientific development of plastics. The notable contribution during this stage was by a Belgian Scientist—Dr. L. Baekeland. He prepared a product, known as Bakelite. It is thermo-setting substance. It was found to be strong and hard material with good insulating property.
- (3) The last stage includes the present trend and it aims at improving the old plastics and producing new varieties of plastics. Such development is mainly responsible for two World Wars during which intensive research was carried out to get plastics with desired properties. The beginning

of this stage was made by an Austrian scientist—Pollak. He prepared a substance from urea and formaldehyde in 1924. This substance was transparent like glass. But it was unbreakable. It was also possible to produce it in many attractive colours and shades. A strong revolution in plastic industry came during the period of second world war (1939-1944). Within such a short period, plastic has proved to be a very important engineering material.

### Composition:

Plastic is an organic substance and it consists of natural or synthetic binders or resins with or without moulding compounds. Various types of resins and commonly used moulding compounds will be discussed later on in this chapter. In general, it may be stated that plastics are compounds of carbon with other elements, such as hydrogen, nitrogen and oxygen. Carbon combines with itself and other elements and it forms more complicated compounds.

The finished product of plastic is rigid and stable at normal temperature. It is, therefore, improper to associate the term plastic to such substances in the ordinary sense of the term. It is, however, to be noted that plastics are organic substances and these are capable of flow when necessary heat and pressure are applied at some stage of their manufacture. The term plastic is, therefore, accepted to be the best one to describe the various diverse products of plastic industry.

### Polymerization:

The simplest substances consisting of one primary chemical are known as *monomers* or *monoliths*. They are to be combined or synthesised to form polymers by the process known as *polymerization*. The properties such as strength, rigidity, elasticity are considerably improved by polymerization and it further leads to the manufacture of plastics in an economic way.

Following are the *two* methods of polymerization:

- (1) Addition polymerization
- (2) Condensation polymerization.

**(1) Addition polymerization:**

In this method, similar or different molecules join together due to opening of double bonds and the molecular weight of the resulting polymer is equal to the sum of the molecular weights of the reacting molecules. There is no loss of any substance in this process. The process involves *three* distinct stages:

- (i) Beginning of the process
- (ii) Expansion of chain
- (iii) End of process.

The polymers obtained by this method are polythylene, polypropylene, polyvinylchloride, polystyrene, polyacrylates, etc.

**(2) Condensation polymerization:**

In this method, low-molecular substances are removed from the high-molecular substances formed from a large number of identical or different molecules. The reaction proceeds with an evolution of ammonia, hydrogen chloride and similar other low-molecular substances.

The polymers obtained by this method are phenol-formaldehyde, carbamide, melamine-formaldehyde, etc.

**Classification of plastics:**

Plastics are classified according to their:

- (1) behaviour with respect to heating,
- (2) structure, and
- (3) physical and mechanical properties.

**(1) Behaviour with respect to heating:**

According to this classification, plastics are divided into *two* groups:

- (1) Thermo-plastic
- (2) Thermo-setting.

The above classification is based on the inherent characteristics of each group. These two groups can further be

divided into several distinct sub-divisions. These sub-divisions are based on the raw materials from which plastics are prepared. It is interesting to note that each of above group contains several hundred different products and with the advance of plastic industry, the number of sub-divisions under each category is constantly increasing.

**(i) *Thermo-plastic:***

The thermo-plastic or heat non-convertible group is the general term applied to plastics which become soft when heated and hard when cooled. The process of softening and hardening may be repeated for an indefinite time, provided the temperature during heat is not so high as to cause chemical decomposition. It is thus possible to shape and reshape these plastics by means of heat and pressure. One important advantage of this variety of plastics is that the scrap obtained from old and worn-out articles can be effectively used again.

**(ii) *Thermo-setting:***

The thermo-setting or heat convertible group is the general term applied to plastics which become rigid when moulded at suitable pressure and temperature. This type of plastics passes originally through thermo-plastic stage. When they are heated in temperature range of  $127^{\circ}\text{C}$  to  $177^{\circ}\text{C}$ , they set permanently and further application of heat does not alter their form or soften them. But at temperature of about  $343^{\circ}\text{C}$ , charring occurs. This charring is a peculiar characteristic of organic substances.

The thermo-setting plastics are soluble in alcohol and certain organic solvents, when they are in thermo-plastic stage. This property is utilised for making paints and varnishes from these plastics.

The thermo-setting plastics are durable, strong and hard. They are available in a variety of beautiful colours. They are mainly used in engineering application of plastics.

**(2) Structure:**

According to this classification, plastics are divided into *two* groups:

- (i) Homogeneous plastic
- (ii) Heterogeneous plastic.

**(i) Homogeneous plastic:**

This variety of plastic contains carbon chain, i.e., the plastics of this group are composed only of carbon atoms.

**(ii) Heterogeneous plastic:**

This variety of plastic is composed of the chain containing carbon and oxygen, nitrogen and other elements.

**(3) Physical and mechanical properties:**

According to this classification, plastics are divided into *four* groups:

- (i) Rigid plastics
- (ii) Semi-rigid plastics
- (iii) Soft plastics
- (iv) Elastomers.

**(i) Rigid plastics:**

These plastics have a high modulus of elasticity and they retain their shape under exterior stresses applied at normal or moderately increased temperatures.

**(ii) Semi-rigid plastics:**

These plastics have a medium modulus of elasticity and the elongation under pressure completely disappears, when pressure is removed.

**(iii) Soft plastics:**

These plastics have a low modulus of elasticity and the elongation under pressure disappears slowly, when pressure is removed.

(iv) *Elastomers* :

These plastics are soft and elastic materials with a low modulus of elasticity. They deform considerably in tension and the deformation disappears rapidly at room temperatures.

**Resins:**

As plastics are classified into *two* groups, according to their behaviour with respect to heating, resins or binders are also broadly divided into the following *two* groups:

- (1) Thermo-plastic resins
- (2) Thermo-setting resins.

(I) *Thermo-plastic resins* :

Following are the commonly used thermo-plastic resins:

- (i) Alkyd
  - (ii) Cellulose
  - (iii) Cumarone-indene
  - (iv) Methyl methacrylate
  - (v) Styrene
  - (vi) Vinyl.
- (i) *Alkyd* :

These resins are made from glycerin and phthalic anhydride. Their chemical composition is adjusted by drying oils. They cool slowly and possess electric properties. They are used for preparing thin films of plastics.

(ii) *Cellulose* :

These resins are derived from various cellulose compounds such as cellulose acetate, cellulose nitrate, cellulose esters, etc. Plastics made from cellulose are as clear as glass. They are tough and strong. They possess excellent electrical properties. It is also possible to obtain all types of colour effects with such plastics.

(iii) *Cumarone-indene* :

These resins become soft over a narrow range of temperature. Their electrical properties do not change with humidity.

dity. They are brittle and are used for floor tiles, rubber manufacture, etc.

(iv) *Methyl methacrylate* :

This resin is also known as *acrylic*. It is derived from coal petroleum and water by a complicated process. It is light in weight and transmit ultra-violet waves of light. It can be cut, sawn or turned. It possesses excellent optical properties and it acts as a good electric insulator. When broken by an impact, it merely cracks and does not shatter away like glass. Plastics prepared from this resin are used for safety glass, coloured and artificial jewels, roof lights, lighting fittings, bath and sink units, etc.

(v) *Styrene* :

This resin is produced from ethylene which is made from petroleum. This resin is light in weight. It transmits ultra-violet waves of light. It possesses very high electric resistance. It is not easily attacked by chemicals. Its water absorption is low. Plastics prepared from this resin are widely used as insulators at radio frequencies in wireless and television industry.

(vi) *Vinyl* :

There are several groups of this type of resin. They are produced by passing acetylene gas through acetic acid or dry hydrogen chloride. The process is carried out under controlled light, heat and pressure. Plastics prepared from this resin are odourless, non-toxic, transparent and colourless. Vinyl chloride possesses high resilience and it is used for wire and cable coatings. Polythylene is a vinyl resin which is tough and flexible and is used for cable covering. Polyvinyl butyral is another variety of vinyl resin which is used in safety glass.

(2) *Thermo-setting resins* :

Following are the commonly used thermo-setting resins:

- (i) Casein
- (ii) Melamine-formaldehyde

- (iii) Phenol formaldehyde
- (iv) Phenol furfuraldehyde
- (v) Urea formaldehyde.

(i) *Casein* :

Casein is a phosphor protein and it is derived by the precipitation of milk with acids. It absorbs moisture and is not very strong. But it is easily workable and it possesses bright attractive appearance. Plastics prepared from this resin are used for buckles, buttons, etc.

(ii) *Melamine-formaldehyde* :

Melamine is obtained from calcium carbide. Formaldehyde is prepared synthetically from methane which is the simplest hydrocarbon. Melamine, when reacted with formaldehyde, forms this resin. It is highly resistant to water and possesses excellent resistance to electrical arcs. Plastics made from this resin are used for electrical insulators, glass-reinforced plastics, preparing papers having high strength in wet condition, decorative laminates in light colours for wall and ceiling linings, etc.

(iii) *Phenol formaldehyde* :

Phenol is carbohic acid. It is extracted from coal-tar or prepared from benzene. When reacted with formaldehyde, it forms this resin. It is highly resistant to heat. It possesses excellent mechanical and electrical properties. It is also not easily attacked by water, dilute mineral acids, organic acids, oil, mild alkalies, common solvents, etc. Plastics prepared from this resin are used for paints, varnishes, preparation of laminated products, electrical fittings, w.c. seats, water-resistant adhesives for plywood, etc.

(iv) *Phenol furfuraldehyde* :

Furfuraldehyde vapours are formed by digesting husks or rice, shells of oat or ground-nut, etc. with sulphuric acid in the presence of a catalyst. These vapours, when reacted with phenol, form this resin. It is dark in colour and resists very high temperatures.

(v) *Urea formaldehyde* :

Urea is prepared from calcium cyanamide or by heating under pressure, a mixture of liquid carbon dioxide and liquid ammonia. Urea, when reacted with formaldehyde, forms this resin. It possesses excellent electrical properties. It is not easily attacked by dilute acids and alkalies, oil, chemicals, water, etc. Plastics made from this resin are widely used for making adhesives for wood and wood products, lighting fixtures such as lamps, reflectors, etc.

**Moulding compounds:**

To give desired properties to finished plastic articles, certain moulding compounds, are to be added to plastics. Following are such moulding compounds:

- (1) Catalysts
- (2) Fillers
- (3) Hardeners
- (4) Lubricants
- (5) Pigments
- (6) Plasticizers
- (7) Solvents.

(1) *Catalysts* :

These compounds are added to assist and accelerate the hardening of resin. For instance, ester acts as catalyst for urea formaldehyde.

(2) *Fillers* :

Fillers are inert materials and they impart strength, hardness and other properties to plastics. The choice of a filler should be carefully made. It should be confirmed that addition of a filler does not have detrimental effect on other properties of plastics. The fillers may be used in the following forms:

- (i) Fibrous fillers
- (ii) Laminated fillers
- (iii) Powder fillers.

(i) *Fibrous fillers:*

They increase thermal resistance and impact strength of plastics. They also increase strength and reduce brittleness of plastics. They are widely used in the manufacture of plastics. The commonly used fibrous fillers are asbestos, wood and glass fibres.

(ii) *Laminated fillers:*

They make the plastics very strong. The commonly used laminated fillers are papers, wood veneers, asbestos cardboards, cotton, etc.

(iii) *Powder fillers:*

They provide valuable properties to plastics such as acid-resistance, water-resistance, etc. They also lead to increase in durability, improvement in hardness and reduction in cost. The commonly used powder fillers are quartz powder, chalk, wood flour, etc.

(3) *Hardners:*

These compounds are added to increase the hardness of resin. For instance, hexamethylen tetramine acts as hardener for phenol formaldehyde.

(4) *Lubricants:*

Lubricants are applied on the surface of moulds so that articles of plastics do not stick to the moulds. The application of lubricants on surface of moulds allows easy removal of articles of plastics from moulds. The commonly used lubricants are graphite, parafine, wax, etc.

(5) *Pigments:*

The addition of pigment helps in *two* ways, namely, they act as fillers and they impart desired colour to plastics. They should be durable and adequately fast to light. The commonly used pigments are zinc oxides, barytes, etc. The selection of pigments should be done in such a way that their addition does not alter or affect the other properties of plastics.

**(6) Plasticizers:**

These compounds are added to improve plasticity and to impart softness to plastics. They should be chemically inert, poorly volatile and non-toxic. The addition of plasticizers facilitate the moulding process of plastic articles. The commonly used plasticizers are camphor, triacetin, tributyl phosphate, etc. The proportion of plasticizers in plastics should not exceed 10 per cent. Otherwise the strength of plastics will decrease.

**(7) Solvents:**

These compounds are added to dissolve the plasticizer. For instance, alcohol is added in cellulose nitrate plastics to dissolve camphor.

**Fabrication:**

Following are the processes involved in the fabrication of articles of plastics:

- (1) Blowing
- (2) Calendering
- (3) Casting
- (4) Laminating
- (5) Moulding.

Each process will now be briefly described.

**(1) Blowing:**

This method of fabrication of articles of plastics is more or less the same as that one employed in glass industry. A lump of plastic material is taken and by blowing, it is converted into hollow plastic articles such as jars, bottles, toys, etc.

**(2) Calendering:**

In this process, the plastic material is allowed to pass between the cylindrical rollers. The process is used to prepare plain flat sheets of plastics.

The process consists of closely placed four revolving

cylinders. The first three cylinders are heated and the last one is kept cold. The plastic material passes between first three cylinders and it is converted into thin sheets. It is cooled while passing through the surface of the cold cylinder. If cloth is to be provided with plastic coating, the cloth is inserted alongwith plastic material between second and third heated rollers. The rollers may be provided with artistic designs which will appear on the finished product.

### (3) *Casting:*

This process is similar in principle to that of metal casting. The resin is heated and when it is in plastic form, it is poured into the mould. Curing of articles is then done either with or without the application of heat. During curing, low pressure may be applied, if necessary.

This process is used to prepare plastics of beautiful colours and it is most suitable for cellulose plastics.

### (4) *Laminating:*

In this process, thermo-setting resins are just applied on sheets of paper, asbestos, etc., to form plastic laminates. The thickness of sheets varies from 0.12 mm to 15 mm. They possess excellent mechanical and electrical properties. Due to the pleasing finish surface, they are used for ornamental and decorative purposes.

### (5) *Moulding:*

This is the most commonly adopted process for the fabrication of plastic articles. The general process consists in placing the raw materials in a mould and then heating it. Moulding can be done by various methods such as compression moulding, extrusion moulding, injection moulding, jet moulding and transfer moulding. The choice of moulding method will depend on the article to be prepared. These methods are briefly described as follows:

#### (i) *Compression moulding:*

In this method, the moulds to receive the plastic material are prepared. The moulds are usually heated and then the

plastic material is placed in the moulds. The moulds are closed and they are heated to a temperature of  $100^{\circ}\text{C}$  to  $200^{\circ}\text{C}$  under a pressure of 100 to  $500\text{ kg/cm}^2$ . The plastic material gets the shape of moulds on account of heat and pressure.

In case of thermo-plastic, the moulds are cooled before articles are taken out. Thus the moulds are to be heated and cooled alternatively in the preparation of thermo-plastic articles. Thus for production of thermo-plastics, this method proves to be uneconomical as considerable time is lost in cooling the moulds.

In case of thermo-setting plastics, it is not necessary to cool the moulds as articles of such plastics get the shape due to chemical action.

(ii) *Extrusion moulding:*

In this method, the resin powder is fed through hopper at the inlet end of the revolving screw. At the outlet end, the material is heated and it is extruded or forced through a nozzle as shown in fig. 14-1. The plastic material as it comes out from nozzle is received in cold moulds.

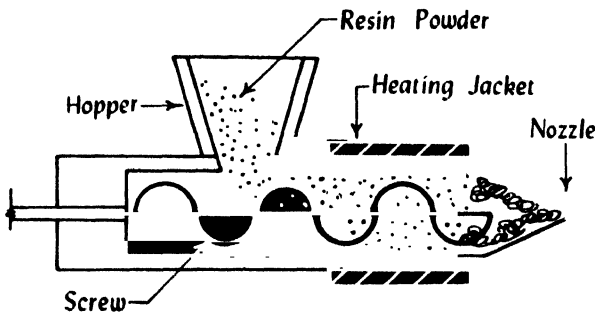

Extrusion moulding

FIG. 14-1

The method of extrusion moulding is adopted for thermo-plastic resins to form narrow ribbons, sheets, etc.

(iii) *Injection moulding:*

This is comparatively a modern method of moulding. The plastic material is loaded, heated and then injected into

the mould. It is then allowed to cool before being taken out from the mould.

As shown in fig. 14-2, the resin powder is allowed to fall through a hopper and it is then pushed by a piston into a hot cylinder. The plastic material is melted and it is then forced to fall in the cool mould under a pressure of about  $1600 \text{ kg/cm}^2$  through nozzle. The article gets the shape of mould and becomes solid.

The process of injection moulding is very much suitable for thermo-plastic resins. The complete process is automatic and articles can be prepared within 10 seconds to one minute. It is thus adopted to prepare plastic articles of small size on a large scale.

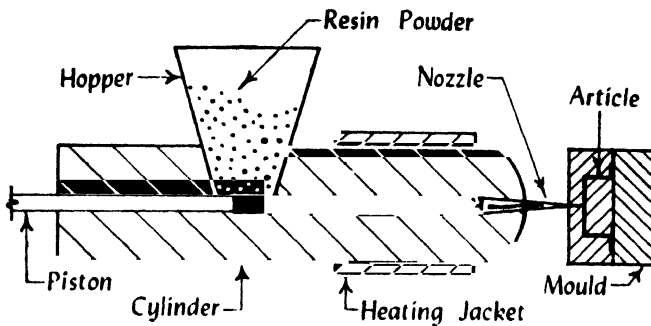

Injection moulding

FIG. 14-2

(iv) *Jet moulding:*

In this method, the plastic material is moderately heated. It is then allowed to pass through nozzle, which is preheated to a high temperature. This method of moulding may be adopted for thermo-plastics as well as thermo-setting materials.

(v) *Transfer moulding:*

When the process of injection moulding is applied to thermo-setting resins, it is known as transfer moulding. In this process, the moulds are also heated before the plastic material is injected through the nozzle. Thus the thermo-setting resins are heated in this process in *two* chambers, namely,

cylinder and mould. The pressure on mould is maintained till the chemical action to prepare the plastic article is completed. The plastic materials are removed from the moulds either mechanically or manually.

### **Properties of plastics:**

To appreciate the importance of plastic as an engineering material, it will be interesting to study its some of the outstanding general properties. It may however be remembered that each plastic material has its own peculiar properties to suit its particular uses. Success of plastic as an engineering material for a particular purpose will depend upon the correct choice of the variety of plastic.

Following are the properties of plastics:

#### **(1) *Appearance:***

Some plastics are completely transparent in appearance. With the addition of suitable pigments, plastics can be made to have appearance of variety of attractive, opaque, stable and translucent colours.

#### **(2) *Chemical resistance:***

Plastics offer great resistance to moisture, chemicals and solvents. The degree of chemical resistance depends on the chemical composition of plastics. Many plastics are found to possess excellent corrosion resistance. Hence they are used to convey chemicals.

#### **(3) *Dimensional stability:***

This property of plastics favours quite satisfactorily with that of other common engineering materials.

#### **(4) *Ductility:***

Plastics lack ductility. Hence their members may fail without warning.

#### **(5) *Durability:***

Plastics are quite durable, if they possess sufficient surface hardness. Plastics, especially thermo-plastic varieties,

are likely to be attacked by termites and rodents. But the danger of such an attack is not very serious due to the fact that plastics have no nutritional value.

**(6) *Electric insulation:***

Plastics possess excellent electric insulating property. They are far superior to ordinary electric insulators.

**(7) *Finishing:***

Any surface treatment may be given to plastics. It is also easy to have technical control during its manufacture. It results in mass production of plastic articles with uniformity of surface finish.

**(8) *Fire-resistance:***

Plastics are organic in nature and hence, all plastics are combustible. But, depending upon the structure, the resistance to high temperature and fire varies considerably among various varieties of plastics. Cellulose acetate plastics burn slowly. Polyvinyl chloride plastics are non-inflammable. Phenol formaldehyde and urea formaldehyde resist fire and they are used as fire-proofing materials.

**(9) *Fixing:***

Plastics can be easily fixed in position. They can be bolted, clamped, drilled, glued, screw-threaded or simply push-fitted in position.

**(10) *Humidity:***

The properties of plastics are governed to some extent by humidity. The strength of plastics containing water attracting groups such as cellulosic plastics, is considerably affected by the presence of moisture. On the other hand, plastics which do not contain water attracting groups such as polyvinyl chloride plastics, offer great resistance to moisture.

**(11) *Maintenance:***

It is easy to maintain plastic surfaces. They do not require any protective coat of paints.

**(12) Melting point:**

Most of plastics have low melting point and melting point of some plastics is only about 50°C. They cannot, therefore, be used in positions having high temperatures or to convey boiling water. In general, it can be said that the coefficient of thermal expansion of plastics is about ten times that of steel. Thermo-setting varieties of plastics are less susceptible to heat than thermo-plastic varieties of plastics. To improve the resistance of plastics to heat, glass fibre reinforcement may be added in the structure of plastics.

**(13) Optical property:**

Several types of plastics are transparent and translucent.

**(14) Sound absorption:**

Acoustical boards are prepared by impregnating fibre-glass with phenolic resins. This material has absorption coefficient of about 0.67.

**(15) Strength:**

An ideal section of plastics for structural member has yet not been designed. Plastics are reasonably strong. The strength of plastics may be increased by reinforcing with various fibrous materials. Plastic members can be used as tensile members as their strength to weight ratio in tension very nearly approaches to that of metals. But the following considerations are responsible to discourage the use of plastics as structural material:

- (i) Plastics are costly.
- (ii) Plastics are subject to creep under constant heavy loads.
- (iii) The behaviour of plastics is very sensitive to changes in temperature.
- (iv) The stiffness of plastics is very poor.

**(16) Thermal property:**

The thermal conductivity of plastics is low and it can be compared with that of wood. Foamed or expanded plastics are among the leading thermal insulators.

**(17) Weather resistance:**

Only limited varieties of plastics can be exposed to weather. The important group of plastics which can resist weather effects is one prepared from phenolic resins. Certain plastics are seriously affected by ultraviolet light in the presence of sunlight. The resistance to sunlight of such plastics can be improved by incorporating fillers and pigments which absorb or reflect the ultraviolet light at the surface. Thus the interior of plastics is protected.

**(18) Weight:**

Plastics, whether thermo-plastic or thermo-setting, have low specific gravity, the average being 1.30 to 1.40. The light weight of plastics reduces the transport costs and facilitates fixing.

**Uses of plastics:**

The uses of particular plastics are mentioned while discussing thermo-plastic resins and thermo-setting resins. The typical uses of plastics in building are summarised as follows:

- (1) bath and sink units,
- (2) cistern ball floats,
- (3) corrugated and plain sheets,
- (4) decorative laminates and mouldings,
- (5) electrical conduits,
- (6) electrical insulators,
- (7) films for water-proofing, damp-proofing and concrete curing,
- (8) floor tiles,
- (9) foams for thermal insulation,
- (10) jointless flooring,
- (11) lighting fixtures,
- (12) overhead water tanks,
- (13) paints and varnishes,
- (14) pipes to carry cold water,

- (15) roof lights,
- (16) safety glass,
- (17) wall tiles,
- (18) water-resistant adhesives, etc.

### Conclusion :

Plastic has emerged as a new engineering material. The properties of various types of plastics make them suitable for wide range of engineering applications. At the same time, they have their own limitations which make them unsuitable in certain cases. But development of plastic industry is very recent and there is much scope in it for research. Hence, with passing of time, their shortcomings or drawbacks may be improved and plastics may be put to still better uses.

The *shortcomings* of plastics can be summarised as follows :

- (1) Most of the plastics possess low heat resistance.
- (2) Plastics are not very hard.
- (3) Plastics disintegrate gradually and because of the effects of light, air and temperature, they lose strength, become soft and get dull, as time passes.
- (4) Plastics exhibit high creep.
- (5) Plastics have a high coefficient of thermal expansion. It varies from  $25 \times 10^{-6}$  to  $120 \times 10^{-6}$  as compared to  $11 \times 10^{-6}$  of steel.

### QUESTIONS

1. Mention brief history of plastics.
2. What is the composition of plastics?
3. How are plastics classified?
4. Describe commonly used thermo-plastic resins.
5. Discuss commonly used thermo-setting resins.
6. Comment upon various moulding compounds.

7. Write short notes on:

- (1) Alkyd
- (2) Casein
- (3) Moulding
- (4) Fillers
- (5) Strength of plastics
- (6) Fire-resistance of plastics
- (7) Acrylic
- (8) Calendering
- (9) Plasticizers
- (10) Urea formaldehyde
- (11) Vinyl.

8. What are the processes involved in fabrication of plastic articles?

9. Enumerate general properties of plastics.

10. Mention the uses of plastics.

11. What is polymerization? Describe its two methods.

12. Write a critical note on plastic as an engineering material.

13. Mention the shortcomings of plastics.

14. Differentiate between the following:

- (1) Catalysts and plasticizers
- (2) Blowing and moulding
- (3) Injection moulding and transfer moulding
- (4) Thermo-plastic resins and thermo-setting resins
- (5) Phenol formaldehyde and phenol furfuraldehyde
- (6) Casting and laminating
- (7) Compression moulding and extrusion moulding
- (8) Plasticizers and lubricants
- (9) Addition polymerization and condensation polymerization
- (10) Homogeneous plastics and heterogeneous plastics
- (11) Rigid plastics and elastomers
- (12) Monomer and polymer
- (13) Soft plastics and semi-rigid plastics
- (14) Fibrous fillers and laminated fillers.

15. Give sketches of the following:
  - (1) Extrusion moulding
  - (2) Injection moulding.
16. Give reasons for the following:
  - (1) The choice of a filler should be carefully made.
  - (2) Compression moulding proves to be uneconomical for production of thermo-plastics.
  - (3) Injection moulding is adopted to prepare plastic articles of small size on a large scale.
  - (4) Plastics are used to convey chemicals.
  - (5) The scrap obtained from old and worn-out articles of thermo-plastics can be effectively used again.
  - (6) The thermo-setting plastics are used for making paints and varnishes.
  - (7) Certain moulding compounds are added to plastics.
  - (8) Lubricants are applied on the surface of moulds.
  - (9) The proportion of plasticizers in plastics should not exceed 10 per cent.
  - (10) All plastics are combustible.
  - (11) Plastics cannot be used in positions having high temperatures or to convey boiling water.
  - (12) Glass fibre reinforcement is sometimes added in the structure of plastics.
  - (13) Polymerization leads to the manufacture of plastics in an economic way.
  - (14) Plastic members can be used as tensile members

# Chapter 15

## MISCELLANEOUS MATERIALS

### General:

In this chapter, brief description of the following remaining miscellaneous engineering materials which are used to a limited extent for engineering purposes will be given:

- I. Abrasives
- II. Adhesives
- III. Asbestos
- IV. Asphalt
- V. Belts
- VI. Bitumen
- VII. Cork
- VIII. Electrical insulators
- IX. Fuels
- X. Gypsum
- XI. Gypsum plaster
- XII. Heat insulating materials
- XIII. Lubricants
- XIV. Rubber
- XV. Sheets for pitched roof coverings
- XVI. Solder
- XVII. Sound absorbent materials
- XVIII. Tar
- XIX. Turpentine.

### I. Abrasives:

An abrasive is a substance which is used to remove excess material by cutting. It polishes soft material and gives it an attractive appearance.

Abrasives are the hardest materials. They are used for engineering purpose in the following forms:

- (1) as abrasive papers or cloths,
- (2) as abrasive stones,
- (3) as grinding pastes with oil,
- (4) in grinding wheels, and
- (5) with some suitable bonding materials.

Abrasives may broadly be divided into the following *two* categories:

- (1) Natural abrasives
- (2) Artificial abrasives.

Natural abrasives occur in nature. The most commonly used natural abrasives are diamond, garnet, flint, emery, corundum, carbonado and sandstone.

With the development of industries, it was found necessary to prepare artificial or synthetic abrasives. These abrasives possess the following *advantages*:

- (1) The amount of abrasive material is more in synthetic wheels.
- (2) The manufacture of synthetic abrasives permits exact duplication of the product.
- (3) The synthetic abrasive can be prepared of desired quality.
- (4) The synthetic wheels of desired size and shape can be prepared.

The most commonly used synthetic abrasives are carbides of aluminium, boric acid and silicon.

## II. Adhesives:

An adhesive is a substance which is used to join two or more parts so as to form a single unit. The application of adhesive has the following *advantages* over the conventional methods of bolting, riveting and welding:

- (1) A wide variety of combinations in joining is possible.
- (2) It can be used for bonding the surfaces of glass, metal, plastics and wood.

- (3) It creates a massive effect.
- (4) It is possible to prevent corrosion between different metals joined by adhesive.
- (5) It produces adequate strength.
- (6) Permeable joint can be made impermeable for water and gas by the application of adhesives.
- (7) The process of applying adhesive is easy, economical and speedy.

The *disadvantages* of adhesives are as follows:

- (1) It is not possible to adopt any adhesive for all substances. Depending upon the properties of substances to be joined, suitable adhesive has to be selected.
- (2) The adhesive substance does not become strong immediately after its application. It requires some time to attain the desired strength.
- (3) The adhesive substance does not generally remain stable at high temperature.

Following factors determine the quality of an adhesive:

- (1) its degree or intensity of sticking,
- (2) its durability,
- (3) its resistance to heat,
- (4) the strength of bond developed after drying or setting,
- (5) the time required to develop the required bond, etc.

Glue is a general term which is used to indicate an adhesive substance. Following are the various types of adhesives:

**(1) *Albumin glues:***

It is a glue of better quality. It is not attacked by water. It is used for making furniture.

(2) ***Animal protein glues:***

It is obtained by boiling waste pieces of skins, bones, etc. of animals with hot water. Animal glue develops strong and tough joints and it is easy to apply. But it is affected by damp and moist conditions. It is available in the form of cakes, flakes, granules, jelly, pearls and sheets. It is used in the manufacture of plywood, laminated timbers, etc.

(3) ***Glues from natural resins:***

It is prepared from natural resins. It is used for labelling, building paper, etc.

(4) ***Glues from synthetic resins:***

These glues are based on synthetic resins. They may either be thermo-setting glues or thermo-plastic glues. The thermo-setting glues become permanent, once they are set. The thermo-plastic glues can be made plastic again by reheating.

All synthetic glues are fire-proof, strong and water-proof. The setting time of synthetic glues can be regulated by varying the type or kind and quality of the hardner. They resist the attack by fungi and they possess non-staining qualities.

The synthetic resins are mainly of *four* types:

- (i) ***Melamine resins:*** They require heat and pressure for setting. They are used in the manufacture of plywood.
- (ii) ***Phenolic resins:*** They are available either in liquid, film or powder form. They require heat and pressure to form a permanent strong bond. They are used in the manufacture of resin-bonded plywood.
- (iii) ***Resorcinol resins:*** They are in the form of dark viscous liquids. They are resistant to bacteria, fungi, heat and moisture. They become hard in short time at low temperatures.
- (iv) ***Urea resins:*** They are available in the form of syrups and powders. They are extensively used in joinery work to form water-resistant glue joints.

**(5) Nitrocellulose glues:**

It is prepared from pyroxilin which is a nitrated cellulose. It is derived by treating cellulose with nitric acid. It produces films which strongly adhere to glass.

**(6) Rubber glues:**

It is prepared by dissolving rubber in benzene. It is used for joining rubber, plastics, glass, etc.

**(7) Special glues:**

These are specially prepared to join metals. Cycleweld is a modified form of rubber and it is used to join aluminium sheets. Araldite is another variety of special glue. It is used to join light metals.

**(8) Starch glues:**

It is prepared from vegetable starch. It has good strength in dry condition. But it is not moisture resistant. It is cheap and is used for inferior quality of plywood.

**(9) Vegetable glues:**

It is prepared from natural gums and starches. It is used for preparing paper board articles, labelling, etc.

**III. Asbestos:**

Asbestos is a naturally occurring fibrous mineral substance. It is composed of hydrous silicates of calcium and magnesium ( $\text{CaSiO}_3$ ,  $3\text{MgSiO}_3$ ). It also contains small amounts of iron oxide and alumina.

**Properties of asbestos:**

- (1) Holes can be drilled and screws can be fitted on its surface.
- (2) It can be cut into pieces.
- (3) It is an excellent insulator for heat and electricity.
- (4) It is fire-proof and acid-proof.
- (5) It is flexible, soft and non-porous.

- (6) It is smooth like glass and silk.
- (7) Its colour is brown, grey or white.
- (8) Its melting point is 1200°C to 1550°C.
- (9) Its sp. gravity is 3.10.

### ***Uses of asbestos:***

- (1) Asbestos cement products have become very popular at present. They are prepared by mixing asbestos fibres with cement. They include sheets and pipes. The sheets are used as roofing material and the pipes are used to convey rainwater, seepage water, etc.
- (2) Asbestos felt can be prepared by coating asbestos fibres with bitumen and it is used as damp-proof layer.
- (3) It is used as covering material for magnetic coils.
- (4) It is used as lining material for fuse box and switch box.
- (5) It is used for insulating boilers, furnaces, etc.
- (6) It is used for preparing fire-proof cloths, ropes, etc.
- (7) It is used to form asbestos paint.

### ***Asbestos cement products:***

The term asbestos cement is used to mean an artificial stone material which is obtained by hardening a mix of cement, asbestos and water. Asbestos serves as a reinforcement and it assists in providing high strength in tension and bending to asbestos cement items. The percentage of asbestos in asbestos cement items will depend on the type and quality of asbestos. But it generally varies from 10% to 20%.

The properties of asbestos cement include high mechanical strength in bending, frost resistance, low heat conductivity, high resistance to attack by mineralised aqueous solutions, high watertightness and small bulk density. However, asbestos cement is brittle and it warps due to changes in humidity and its strength is lowered when saturated by water. Coloured asbestos cement products can also be prepared by the use of dyes and coloured enamels, resins and varnishes.

#### IV. Asphalt:

Asphalt is a mechanical mixture of inert mineral matter like alumina, lime, silica, etc. and the asphaltic bitumen.

##### *Classification of asphalt:*

Asphalt is classified into *two* categories as follows:

- (1) Natural asphalt
- (2) Residual asphalt.

##### (1) *Natural asphalt:*

This variety of asphalt is obtained from nature. It is further subdivided into *two* groups, namely, *lake asphalt* and *rock asphalt*.

Lake asphalt is obtained from lakes at Trinidad and Bermudez (South America) at depths varying from 3 to 60 metres. It contains about 40 to 70 per cent of pure bitumen. Water content is about 30 per cent. The rest is impurities. It is refined by boiling in a tank. Water evaporates and impurities collect at the top. These impurities are removed. This refined lake asphalt is used widely for road and pavement construction.

Rock asphalt is obtained from rocks at Switzerland, France, etc. It contains about 10 to 15 per cent of pure bitumen. The rest consists of calcareous materials. The rocks are put on the road surface after being crushed and heated. The road surface is then formed by rolling. This asphalt can also be used for roofing sheets, paving tiles, etc.

##### (2) *Residual asphalt:*

This variety is also known as *artificial asphalt*. It is obtained by the fractional distillation of crude petroleum oils with an asphaltic base. Such process leaves a solid substance in the retort. This solid substance is the residual asphalt.

##### *Forms of asphalt:*

Following are the usual forms of asphalt:

##### (1) *Asphaltic cement:*

It is prepared by blowing air through melted asphalt at

high temperature. Asphalt is oxidised and the resulting product is plastic in nature and it is highly resistant to varying climatic conditions. It is used for flooring, roofing, water-proofing and filler in expansion joints in concrete.

(2) *Asphaltic emulsion:*

It is produced by mixing asphalt with 50 to 60 per cent water in presence of 1 per cent of emulsifying agent. When water evaporates, the emulsion breaks and it forms a water-proofing layer. It can be applied in cold condition.

(3) *Cut-back asphalt:*

This is a liquid asphalt. It is prepared by dissolving asphalt in a volatile solvent. It can be applied at normal temperature in cold condition. It is used for preparing bituminous paints, for repairing roofs, etc.

(4) *Mastic asphalt:*

It is produced by heating natural asphalt with sand and mineral fillers. The resulting product is a voidless impermeable mass. The hardness and melting point of mastic asphalt can be controlled during its manufacture. It may either be in solid or semi-solid state. But when heated to a suitable temperature, it can be made sufficiently fluid so as to be able to spread by a hand float. It is used as a material for damp-proofing and water-proofing.

***Properties of asphalt:***

- (1) It is a water-proof material.
- (2) It is good insulator of electricity, heat and sound.
- (3) It is non-inflammable.
- (4) It is not attacked by acids.
- (5) It is resilient and reasonably elastic.

***Uses of asphalt:***

Due to properties mentioned above, asphalt is widely used for various engineering purposes as follows:

- (1) as damp-proof courses,
- (2) as water-proof layers for tanks, basements, swimming pools,

- (3) for preparing paints and roofing felts,
- (4) for constructing roads and pavements, etc.

## V. Belts:

Belts are used to drive machinery or to transmit power or to run mechanical conveyors. Brief descriptions of the materials which are usually used to make belts are given as follows:

### (1) *Balata:*

These belts are formed by impregnating canvas with balata which is a milky fluid present in rubber trees and similar other plants. These belts are water-proof. Grease or oil does not affect them.

### (2) *Canvas:*

These belts are prepared by impregnating canvas with different resins. They are prepared in 2 to 10 ply or layer thickness.

### (3) *Cotton:*

These belts may or may not be impregnated with rubber compounds. They are used for driving fans in automobiles, conveyor belts, etc.

### (4) *Leather:*

These belts should not be allowed to get dry and brittle. Good leather should not stretch by about 15% of its length and its tensile strength should be about 175 kg/cm<sup>2</sup>. Leather belts are available in suitable widths and special water-proof leather belts which can be used in moist places are also available.

### (5) *Rubber:*

These belts are reinforced with cotton, jute, canvas, etc. These belts are quite cheap and they are available in any lengths and widths. These belts have better grip on pulley. They also resist deterioration by moisture. Their tensile strength is quite high about 400 kg/cm<sup>2</sup>. These belts should, however, not come in contact with grease and oils.

## VI. Bitumen:

Bitumen is the binding material which is present in asphalt. It is also sometimes called mineral tar. It is obtained by partial distillation of crude petroleum. It is chemically a hydro-carbon. It is insoluble in water, but it completely dissolves in carbon bisulphide.

Bitumen is black or brown in colour and it is obtained in solid or semi-solid state. Its applications are same as residual asphalt.

### *Forms of bitumen:*

Following are the usual forms of bitumen:

(1) *Bitumen emulsion:*

It is a liquid product containing bitumen to a great extent in an aqueous medium. The bitumen is in a very finely divided state and it is suspended in the aqueous medium with the help of some suitable stabilising agents.

(2) *Blown bitumen:*

It is a special type of bitumen which is obtained by passing air under pressure at a higher temperature. Such bitumen can be used as roofing and damp-proofing felts, in the manufacture of pipe asphalts and joint fillers, as heat insulating material, etc.

(3) *Cut-back bitumen:*

It is obtained by fluxing asphaltic bitumen in presence of some suitable liquid distillates of coal tar or petroleum.

(4) *Plastic bitumen:*

It consists of bitumen, thinner and a suitable inert filler. The amount of inert filler is about 40 to 45 per cent. It is used for filling cracks in masonry structures, for stopping leakages, etc.

(5) *Straight run bitumen:*

When the bitumen is being distilled to a definite viscosity or penetration without further treatment, it is known as straight run bitumen.

## VII. Cork:

Cork is obtained from the bark of cork oak trees. The bark is ground, cleaned and baked. During baking, the natural resin present in cork comes out and binds the material into a homogeneous mass.

### *Properties of cork:*

- (1) It is a good insulator of electricity and sound.
- (2) It is light in weight.
- (3) It is not attacked by heat and moisture.
- (4) It is porous.
- (5) It is resilient and reasonably elastic.

### *Uses of cork:*

Cork is widely used for preparing cork sheets and boards, bottle stoppers, packing gaskets, etc.

## VIII. Electrical insulators:

A body is said to possess electrification when it attracts other bodies, the attraction being different from the gravitational attraction. Electrification is not a fundamental property of matter because it remains unelectrified under ordinary conditions and it becomes electrified only after the electrification has been produced by certain causes.

All substances may broadly be divided into *two* groups:

- (1) Conductors
- (2) Non-conductors.

### *(1) Conductors:*

In case of a conductor, if one point of the body of the substance is by any means electrified, the electrification immediately spreads all over the body or in other words, conductors are the substances which are used to produce easy and smooth flow of electricity. The best conductors are the metals and solutions of most salts in water. Wires made of copper, aluminium, etc. are widely used as conductors.

## (2) *Non-conductors:*

In case of a non-conductor, the electrification produced does not spread over the entire body, but it remains in the neighbourhood of the point where the electrification took place. The non-conductors are also known as insulators. There is no substance which can be considered as a perfect insulator. But glass (especially when it has been boiled in water and is then kept in a dry atmosphere), paraffin, sulphur, plastics, rubber, asbestos and fused quartz are sufficiently good insulators for all practical purposes. Petroleum, oil, etc. are the important liquid insulators.

Electric insulators may be in the form of solids, liquids or gases. But solid and liquid insulators are important from the commercial point of view. When a gas is in the normal condition, it conducts electricity to a very small extent. But it can be made to conduct electricity freely, when it has its temperature raised sufficiently and when it has been traversed by rays given out by certain substances such as uranium, radium, thorium, etc.

The term *dielectric* is used to mean a substance capable of supporting an electric stress and its strength or power to resist an electric stress is known as *dielectric strength*. The properties of a good electrical insulator can be summarised as follows:

- (1) desired chemical stability,
- (2) high dielectric strength,
- (3) high electrical resistance,
- (4) high moisture resistance,
- (5) high thermal resistance,
- (6) low dielectric constant,
- (7) low power factor,
- (8) suitable mechanical and physical properties for efficient working, etc.

It may however be noted that there is no hard and fast line of demarcation between the two groups mentioned above. Certain substances such as dry wood and paper have intermediate properties and hence, they are sometimes referred to as *semi-conductors*.

## IX. Fuels:

These are the substances which are capable of creating heat energy. Such energy can then be put to some engineering or industrial use. Depending upon the state in which they occur, fuels are classified into the following *three* groups:

- (1) Solid fuels
- (2) Liquid fuels
- (3) Gaseous fuels.

### (1) *Solid fuels:*

The important solid fuels are as follows:

#### (i) *Charcoal:*

It is prepared by burning wood in a kiln with limited quantity of air. It is used to produce gas for domestic purposes.

#### (ii) *Coal:*

It is the chief source for producing cheap power. It is formed by the bacterial decomposition of vegetable matter under great pressure and in absence of air. Its colour is black or dark brown. This is a natural solid fuel.

#### (iii) *Coke:*

It is prepared by heating the powdered coal in special ovens and then quenching the whole mass in cold water. It is better than coal and is the most suited for metallurgical purposes.

#### (iv) *Wood:*

It is obtained from nature and can be used as fuel.

### (2) *Liquid fuels:*

The important liquid fuels are as follows:

#### (i) *Alcohol:*

These are of various types such as ethyl alcohol, methyl alcohol, etc. They are used to serve as fuels for motors, aeroplanes, etc.

(ii) *Crude oil:*

This occurs in nature and it can be used as fuel after giving proper treatment to it.

(iii) *Petroleum:*

This is the product obtained by the distillation of organic matter in nature. It is refined and its distillation yield various artificial liquid fuels such as gasoline, gas oil, kerosene, etc.

(3) *Gaseous fuels:*

The important gaseous fuels are as follows:

(i) *Coal gas:*

This gas is obtained by thermal decomposition of coal at high temperature in absence of air.

(ii) *Natural gas:*

This is obtained from natural underground sources. It is associated with petroleum under pressure.

(iii) *Producer gas:*

This gas is obtained by controlled combustion of coal, coke or charcoal in a blast of air. It is more powerful. It is used in the manufacture of glass, steel, etc.

The gaseous fuels require less air for combustion, they ignite readily and they do not leave any residue. They, however, require a large space for storage.

## X. Gypsum:

Gypsum is the hydrated sulphate of calcium and its chemical composition is  $\text{CaSO}_4 \cdot 2\text{H}_2\text{O}$ . It contains 79.1 per cent calcium sulphate and 20.9 per cent water. It is a white crystalline substance. Its density is  $2.3 \text{ g/cm}^3$ . It is soft, hardness being equal to 2. As a binding material, gypsum quickly sets and hardens. Its initial setting time after addition of water is about 4 to 6 minutes and its final setting time is about 30 minutes. Its solubility in water is very

poor, about 1 part of gypsum in 495 parts of water. It is soluble in hydrochloric acid. But it is insoluble in sulphuric acid. Gypsum very seldom occurs in nature in pure state. It contains impurities such as alumina, calcium carbonate, magnesium carbonate and silica. Gypsum containing upto 70 per cent of  $\text{Ca SO}_4, 2\text{H}_2\text{O}$  can be used as a building material.

The physical forms of gypsum may be crystals as selenite, fibrous as satin spar and massive as alabaster. It is mainly used in the manufacture of cement to increase its setting time. It is also used to prepare plaster of Paris and gypsum boards. These boards are formed by mixing gypsum with asphalt and they are hard and strong boards with insulating properties. Gypsum is also used as a filler in paint, paper and rubber industries.

Table 15-1 shows the areas from which gypsum is available in India. Rajasthan contributes about 90 per cent of annual production of gypsum.

**TABLE 15-1**  
**GYPSUM REGIONS IN INDIA**

Sr.No.	State	Districts
1.	Andhra Pradesh	Nellore
2.	Gujarat	Bhavnagar, Halar, Kutch and Porbander
3.	Jammu and Kashmir	Uri
4.	Madras	Tiruchirapalli
5.	Rajasthan	Barmer, Bikaner, Jaisalmer and Jodhpur
6.	Uttar Pradesh	Dehradun and Garhwal

Gypsum-based products can be obtained from gypsum, water and aggregate. They may be solid or hollow and they may be reinforced or non-reinforced. Artificial strengthening of gypsum items by reinforcing or fibrous materials becomes necessary because gypsum is very brittle in nature. If steel reinforcement is used, a protective coat should be provided as steel is susceptible to corrosion.

Gypsum items possess the following important properties:

- (1) They are incombustible.
- (2) They possess relatively small bulk density.
- (3) They serve as good sound absorbers.

However, these items have poor strength in wet state and they develop high creep under load, especially in moist surroundings. Hence gypsum items give excellent performance in dry state and at places having not more than 60% relative air humidity. Sometimes water-proof paints or pastes are applied on the surface of gypsum items to improve their moisture resistance and water-resisting properties.

### **XI. Gypsum plaster:**

When finely ground gypsum is heated at temperature of 160°C to 170°C, it loses about 14.7 per cent of its water content in the form of steam. The resulting product is hemihydrate of calcium sulphate and it is known as first settle plaster or *plaster of Paris*. When water is added to plaster of Paris, it hardens in three to four minutes. Hence to extend the setting time, suitable retarders are added to it. The usual retarders are clay, citric acid, glue, gum, starch and sugar. The term hemihydrate gypsum plaster is used to indicate plaster of Paris with retarder.

On heating further upto a temperature of about 200°C, entire water of crystallisation is driven off and the resulting product is known as gypsum anhydrite or hard burnt plaster. The setting time of gypsum anhydrite is more and to shorten it, accelerators are added to it. The common accelerators are alum, potassium sulphate and raw gypsum. The term anhydrous gypsum plaster is used to indicate gypsum anhydrite with accelerator.

Following are the properties and uses of gypsum plaster:

- (1) It is a fire resisting material and it does not allow heat to pass easily. Hence it is used as an insulating material to protect wood or metal columns and beams from high temperature.
- (2) It is light in weight. To decrease the weight further, fillers such as granulated cork, saw dust, wood shavings, etc. may be added to it. Such fillers also improve heat and sound insulating quality of gypsum plaster.
- (3) It is practically not affected by bacteria.

- (4) It is slightly soluble in water, about 2 gm per litre. Hence it cannot be adopted for damp conditions and external work. Bags containing gypsum plaster should therefore be stored in dry place.
- (5) It is used for ornamental plaster work and for preparation of boards and blocks. Gypsum plaster boards are used for ceiling, for internal lining of wall and for partition walls. They are cheap, easy to work, light in weight and fire-proof.
- (6) It requires small proportion of sand and other aggregates. When used as base coat, sand or light weight aggregate or wood fibre is added. When used as final coat, lime putty is added.
- (7) It sets by natural process of crystallisation. Hence it can be applied with ease and without wastage.
- (8) It sets with little change in volume and with negligible shrinkage on drying.
- (9) It shows good adhesion to fibrous materials.

## **XII. Heat insulating materials:**

Heat insulating materials are required to grant protection against heat and cold. These materials are generally porous and their properties are governed not only by their porosity but also by the nature of pores, their distribution, size and whether they are open or closed. The materials with a greater number of fine, closed and air-filled pores are the best heat insulating materials. The bulk density of heat insulating materials is usually below  $700 \text{ kg/m}^3$  and their coefficient of heat conductivity does not exceed  $0.18 \text{ k cal/m. hr. }^\circ\text{C}$ .

If heat insulating materials are properly used in building construction, they greatly reduce the heat losses to the environmental medium through wall structures and as a result of this, fuel consumption is reduced. Thus the economic efficiency of thermal insulation is very high and the investments made in heat insulating materials can be recovered in a short duration of time.

In general, it can be stated that the low heat conductivity of heat insulating materials is due to their air-filled pores. Hence if their efficiency is to be maintained, it should be seen that these pores are not covered with a film of water or are filled with water because the coefficient of heat conductivity of water is about 25 times higher than that of air. Hence heat insulating materials should be protected against the moisture.

TABLE 15-2

DENSITY, THERMAL CONDUCTIVITY AND THERMAL RESISTIVITY OF SOME OF THE COMMON BUILDING AND INSULATING MATERIALS

No.	Material	Density in kg/m <sup>3</sup>	Thermal conductivity K in $\frac{\text{kilocalories}}{\text{m hr } ^\circ\text{C}}$	Thermal resistivity 1/K
1.	Artificial stone	1760	1.11	0.88
2.	Asbestos cement sheet	1520	0.25	4.00
3.	Asphalt	2240	1.05	0.95
4.	Cement concrete (1:2:4)	2240 to 2480	1.24	0.80
5.	Compressed straw slab	368	0.074	13.51
6.	Fibreboard	240 to 400	0.046 to 0.056	21.74 to 17.86
7.	Glass	2510	0.905	1.10
8.	Glass cellular	168	0.061	16.40
9.	Glass fibre	48	0.029	34.50
10.	Granite	2640	2.52	0.40
11.	Hair felt	80	0.034	29.40
12.	Limestone	2180	1.32	0.76
13.	Ordinary bricks	1760	0.70 to 1.44	1.43 to 0.70
14.	Plastering	1280 to 1600	0.50	2.00
15.	Sand-lime bricks	1840	0.93	1.07
16.	Sandstone	2000	1.12	0.90
17.	Saw dust	192	0.051	19.60
18.	Terrazo	2430	1.363	0.73
19.	Timber	480 to 720	0.124	8.00
20.	Wood-wool slab	400	0.071	14.08

The choice of an insulating material depends on its cost, area to be covered, standard of insulation required and the cost of heating or cooling. The thermal insulating material

should be reasonably fire-proof, non-absorbent of moisture, able to resist attack of small insects and not liable to undergo deformation. The usual insulating materials are rock wool, slag wool, fibreboard, flexible blankets, saw dust, wood shavings, cork board slabs, mineral wool slabs, aluminium foils, products of cement concrete with light weight aggregates, gypsum board, asbestos cement board, chip board, foam glass, gasket cork sheet, foam plastic, etc.

Table 15-2 shows the density, thermal conductivity and thermal resistivity of some of the common building and insulating materials. In general, it may be stated that the materials of low density provide better thermal insulation than those of higher density.

### **XIII. Lubricants:**

In order to prevent the contact between two surfaces or parts of a moving machine, lubricants or lubricating materials are inserted. The functions of a lubricant are:

- (1) to facilitate easy motion of the moving parts;
- (2) to prevent loss of energy due to friction and thereby to increase the efficiency of machine; and
- (3) to reduce wear and tear of parts.

#### ***Types of lubricants:***

Lubricants are broadly classified in *two* categories:

- (1) Solid lubricants
  - (2) Liquid lubricants.
- (1) *Solid lubricants:*

The usual solid lubricants are graphite, mica and soapstone. They are suitable for very great pressure and temperature with slow speed. The solid lubricants are slowly converted into powder form. In most of the cases, the particles of solid lubricants prove harmful to the moving parts of the machinery and hence, they are recommended only under limited circumstances.

(2) *Liquid lubricants:*

In general practice for all conditions, liquid lubricants are used. Following are the characteristics of a good liquid lubricant:

- (1) Its consistency should more or less remain unchanged with changes in temperature.
- (2) It should be greasy in nature. Otherwise it will be thrown away.
- (3) It should be of light colour where supervision is necessary.
- (4) It should not contain impurities.
- (5) It should not leave too much carbon deposit when it burns at high temperature.
- (6) It should not make the parts which are coming in its contact unclean.
- (7) Its melting point should be low and its boiling point should be high.
- (8) Its viscosity should be proper. If it is low, the film of liquid lubricant will not last and if it is high, it will result in more frictional resistance. Viscosity increases with increase in temperature .

The *varieties* of liquid lubricants are as follows:

- (1) Animal oils
  - (2) Blended oils
  - (3) Greases
  - (4) Mineral oils
  - (5) Vegetable oils.
- (1) **Animal oils:**  
These oils are derived from fats of animals. Table 15-3

shows the properties and uses of the common types of animal oils.

**TABLE 15-3**  
**ANIMAL OILS**

Sr.No.	Name	Properties	Uses
1.	Lard oil	It is obtained from lard. Its melting point is 27°C. It is colourless or pale yellow. It becomes solid when cooled.	It is a lubricating oil of superior quality and it is used for important jobs.
2.	Neat's foot oil	It is obtained by boiling with water the fats and other parts of cattle. Its sp. gr. is 0.916. Its colour is pale yellow.	It is used for delicate mechanisms such as clocks, guns, sewing machines, etc.
3	Tallow oil.	It is derived by hydraulic pressure from tallow which is animal fat obtained from cattle.	It gives an excellent lubricant oil when mixed with mineral oil.
4.	Whale oil	It is derived from a type of fish — whale. It is thin and pale yellow in colour. Its sp. gr. is 0.88.	It is used for light machineries.

### (2) Blended oils:

These oils are prepared by mixing mineral oils with animal oils or vegetable oils. The blended oils are economical and the mineral oils become less volatile in presence of animal oils or vegetable oils.

### (3) Greases:

Grease is a petroleum product and its properties mainly depend on its soap contents. The percentage of liquid oil varies from 50 to 98 and that of soap varies from 50 to 2. Greases are used as semi-solid lubricants under the following circumstances:

- (i) It is not possible to maintain oil films either due to high pressures or due to intermittent operations.
- (ii) Large amount of dust is present in air.
- (iii) Lubrication is to be carried out under extreme moisture conditions.
- (iv) Oil dripping is undesirable.

However, greases offer more friction and cause greater wear and tear. To improve the properties of greases, fillers like graphite, mica, talc, etc. are added. It is an excellent lubricant for the axle boxes of railway rolling stock.

**TABLE 15-4**  
**VEGETABLE OILS**

Sr.No.	Name	Properties	Uses
1.	Castor oil	It is extracted from the seed of castor oil plant. Its sp. gr. is 0.96. It is colourless or pale green. It is insoluble in petroleum.	It is used as lubricant for vehicles.
2.	Colza oil or rape-seed oil	It is obtained from the seed of rape plant which belongs to the cabbage family. It is extracted either by pressure or with solvents. The refined oil is pale yellow in colour, harsh in taste and of peculiar smell.	It is used as lubricant for delicate instruments.
3.	Hazel-nut oil	It is obtained by pressing the kernel of nuts of the hazel tree which belongs to oak family.	It is used as lubricant for clocks and other delicate mechanisms.
4.	Olive oil	It is obtained from olive fruits. It is colourless or golden yellow in colour.	Its superior quality is edible. Lower grades of this oil are used as lubricants.
	Palm oil	It is derived from the kernels of the palm fruits. Its sp. gr. is 0.91 and its melting point is 28°C. Its colour is pale yellow. It possesses pleasant smell and taste.	It is used as lubricant for delicate mechanisms.

(4) Mineral oils:

These oils are derived from crude petroleum. They are stable and cheap. They have low viscosity. Mineral oils of heavy type have sp. gravity of 0.88 to 0.92 and their boiling point is above 300°C. Heavy mineral oils are most suitable as lubricants for light bearings running at high speeds.

(5) Vegetable oils:

These oils are derived from vegetables. Table 15-4 shows the properties and uses of the common types of vegetable oils.

***Methods of applying lubricants:***

The lubricants are applied in the following ways:

- (1) Force feed method
- (2) Gravity feed method
- (3) Mechanical feed method.

(1) *Force feed method:*

In this method, the lubricant is forced under pressure at the desired points.

(2) *Gravity feed method:*

The lubricant in this method is applied as follows:

- (i) The drops of lubricant are poured in the moving parts by hand.
- (ii) The lubricant is conveyed by capillary action through cotton wick. One end of cotton wick is submerged in the lubricant and at the other end, it falls on the moving parts due to its own weight.
- (iii) The lubricant is taken in a vessel and arrangement is made in such a way that lubricant falls in the form of drops on the moving parts.

(3) *Mechanical feed method:*

In this method, a moving chain is fitted with the machine. The chain is suspended in a vessel containing the lubricant. At every turn, a small quantity of lubricant is conveyed by the chain at the desired points of the mechanism and the excess lubricant returns to the vessel.

#### XIV. Rubber:

Rubber is a very important engineering material for any nation as it is widely used for military accessories, the most important one being tyre industry.

##### *Types:*

Rubber is of the following *two* types:

- (1) Natural rubber
- (2) Synthetic rubber.

##### (1) *Natural rubber:*

This variety of rubber is obtained from latex or milky juice tapped from rubber trees. These trees grow in hot moist climate in a region about 12 degrees on either side of the equator and they are abundant in countries like Ceylon, Malaya, North Africa, Mexico, Singapore, etc. A rubber is a fast growing large tree.

The process of obtaining natural rubber is carried out in the following *four* stages:

- (i) Plantation
- (ii) Tapping latex
- (iii) Purification
- (iv) Coagulation.

##### (i) Plantation:

Rubber trees are planted. They start oozing after a period of about 5 to 7 years and continue to ooze out for a life of about 30 years. A normal rubber tree gives about 1 to 1.5 kg of dry rubber per year.

##### (ii) Tapping latex:

A vertical groove about 60 cm long is made in the rubber tree by means of a pointed knife at a height of about 1 metre from ground level. The vertical groove is connected to slanting grooves inclined upwards as shown in fig. 15-1. An earthenware pot is attached at the lower end of vertical groove to collect the latex that oozes out of the tree. Latex from the pot is taken by the tapper everyday or every alternate

day and at that time, the grooves are slightly widened. Care should be taken to see that grooves do not penetrate beyond the cambium layer of the tree.

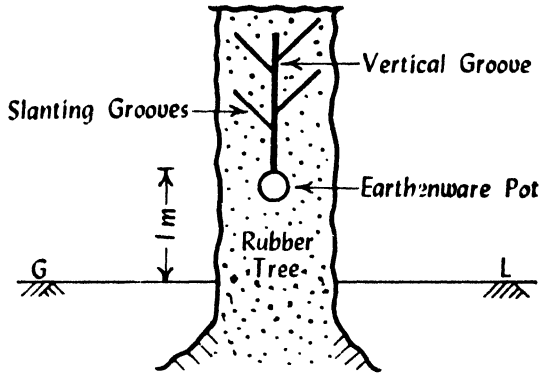

Taking out latex from rubber tree

FIG. 15-1

(iii) Purification:

The impurities such as leaves, sand, debris, etc. which are present in fresh latex are then removed.

(iv) Coagulation:

Latex is then converted into a massive form by the process of coagulation. The coagulant usually adopted is weak acetic acid. The addition of coagulant converts latex into curd like form. It is then passed through rollers. Water from latex is thus separated out and natural rubber is obtained in the form of globules or sheets.

(2) *Synthetic rubber:*

The term synthetic or artificial rubber is used to indicate rubber-like materials which are produced by chemical processes. These are generally prepared from acetylene gas and are available under different trade names such as Buna-S, Butyl, Neoprene, Silicon, etc. Synthetic rubber possesses some unusual properties which are not possible with natural rubber. The elasticity of synthetic rubber is much more than natural rubber and light rays are also effectively resisted by synthetic rubber. With the growth of petro-chemical industries, India will be in a position to produce more than one lakh tonne of synthetic rubber per year.

***Vulcanization:***

Crude rubber becomes soft and sticky in summer and it becomes hard and brittle in winter. For making the rubber fit for use for all the seasons, crude rubber is to be vulcanized. For this purpose, small quantity of sulphur is added to crude rubber and the mixture is heated. A very complicated chemical process takes place and rubber becomes hard and resistant to changes in temperature. This process is known as vulcanization. If the percentage of sulphur varies from 1 to 5, soft rubber is obtained and if it is about 30, hard rubber is obtained. The heating temperatures for soft rubber and hard rubber are respectively 130°C and 170°C. The effects of vulcanization are:

- (1) The permanent set becomes small.
- (2) The tensile strength is considerably increased.
- (3) The vulcanized rubber is more durable.
- (4) The vulcanized rubber offers great resistance to friction and solvents.
- (5) The vulcanized rubber is comparatively less susceptible to temperature changes.

The soft vulcanized rubber is used for soles of boots and other ordinary things. The hard vulcanized rubber is used for tyres, belts, etc.

***Compounding of rubber:***

To give desired properties to rubber, certain compounds are to be added to rubber. The usual compounds which are used for natural rubber and synthetic rubber are as follows:

- (1) Accelerators
- (2) Accelerator activators
- (3) Anti-oxidants
- (4) Fillers
- (5) Hardeners
- (6) Pigments
- (7) Plasticizers
- (8) Vulcanizing agents.

(1) *Accelerators :*

The addition of accelerators decreases the period of preparation of rubber and the properties of rubber are also considerably improved.

(2) *Accelerator activators :*

The composition of rubber is greatly improved by addition of accelerator activators such as zinc oxide, fatty acids, etc.

(3) *Anti-oxidants :*

The addition of anti-oxidants results in the lengthening of oxidation process of rubber. These substances thus act as negative catalysts. The usual anti-oxidants are wax, phenols, phosphates, etc.

(4) *Fillers :*

The fillers work as inert materials and they considerably increase the rigidity and strength of rubber. The usual inert fillers are cotton, carbon, etc.

(5) *Hardeners :*

These compounds are added to increase the tensile strength and hardness of rubber. When hardeners are added, the manufacture of rubber at high temperatures can be carried out smoothly. The usual hardeners are barium sulphate, calcium carbonate, magnesium carbonate, sealing wax, etc.

(6) *Pigments :*

The addition of pigments helps in *two* ways, namely, they act as fillers and they impart colour to rubber. Table 15-5 shows the pigments to be used to get different colours.

**TABLE 15-5**  
**PIGMENTS FOR RUBBER**

Sr.No.	Colour	Pigment
1.	Black	Carbon black
2.	Brown	Antimony oxide
3.	Green	Chromium oxide
4.	Red	Ferric oxide
5.	White	Zinc oxide
6.	Yellow	Lead chromate

(7) *Plasticizers :*

These compounds are added to improve plasticity and to impart softness to rubber. The commonly used plasticizers are wax, resin, vegetable oil, etc.

(8) *Vulcanizing agents :*

The process of vulcanization considerably improves the important properties of rubber. Sulphur is the most commonly used vulcanizing agent.

***Properties of rubber :***

The important properties of rubber are as follows:

- (1) It can absorb shocks due to impact.
- (2) It can contain liquids and gases.
- (3) It creeps or extends in length when force is applied over it.
- (4) It is a bad conductor of heat.
- (5) It is plastic in nature and hence, it can be moulded to desired shapes.
- (6) It is possible to alter considerably its properties by the processes of vulcanizing and compounding.
- (7) It possesses the quality of flexibility.
- (8) It resists abrasion in a better way.
- (9) The natural rubber should be protected from sunlight and should not be allowed to come in close contact with oils, organic liquids, etc.
- (10) The outstanding property of rubber is that it is capable to undergo great deformation without being structurally damaged. It is thus reasonably elastic.
- (11) The synthetic rubber offers great resistance to acids, petroleum, etc.

***Uses of rubber :***

The important engineering uses to which rubber is put up are as follows:

- (1) It is used as a gasket to make doors and windows air tight as in case of refrigerators, vehicles, air-conditioned rooms, etc.

- (2) It is used as a lining material for parts of machines subjected to heavy friction and for tanks to be used in chemical processes.
- (3) It is used for preparing tyres of vehicles and machines.
- (4) It is used to prepare rubber threads which are useful as wires, ropes, etc.
- (5) It is widely used for absorbing shocks and for reducing vibrations in machines.
- (6) Synthetic rubber, in particular, may be used for hose-pipes to carry petrol and kerosene oil, gaskets, insulation for high tension wires, etc.

### ***Forms of rubber:***

The important forms of rubber are as follows:

- (1) Crepe rubber
- (2) Foam rubber
- (3) Guayule rubber
- (4) Gutta percha rubber
- (5) Smoked rubber
- (6) Sponge rubber.

#### (1) *Crepe rubber:*

This variety is one form of crude rubber. During the process of coagulation, certain chemicals are added and the rubber is allowed to pass through many rollers. This rubber has irregular rough surfaces and hence, it is known as crepe rubber.

#### (2) *Foam rubber:*

In the liquid latex, chemicals producing gases are added and the mixture is well stirred till foam is formed. It is then converted into solid form and it is given the desired shape. Foam rubber is widely used for pillows, packing pads, etc.

#### (3) *Guayule rubber:*

This type of rubber is a variety of natural rubber and it is available in North America. It is prepared from the branches of guayule. It contains 70% of hydro-carbon, 20% of resin, 10% of insoluble materials, cellulose, lignin, etc.

(4) *Gutta percha rubber:*

This type of rubber is a variety of natural rubber and it is prepared from the leaves of trees known as *dichopsis gutta* and *palaquium gutta*. It becomes soft and sticky at a temperature of about 100°C. It absorbs less water as compared to other varieties of rubber. It is the best material for preparing ropes of submarine.

(5) *Smoked rubber:*

This variety is one form of crude rubber. After coagulation, the rubber pieces are dried in a room filled with smoke at a temperature of about 40°C to 50°C. As drying is carried out in a smoke-room, it is known as smoked rubber.

(6) *Sponge rubber:*

This rubber is prepared by adding sodium bicarbonate during the process of vulcanization. Evaporation of moisture leaves pores which result in sponge rubber. It is a good insulating material for heat and sound.

***Reclaimed rubber:***

The important quality of rubber is that it can be reclaimed or in other words, it possesses heavy scrap value. The worn out rubber articles are cut into small pieces which are then grinded into powder form. The metallic material is removed from the powder with the help of magnets. The required ingredients are then added in the powder and crude rubber is then prepared.

*Advantages of reclaimed rubber:*

- (1) It can be prepared speedily.
- (2) It is cheap as cost of raw materials is low.
- (3) It is durable.
- (4) Its composition is uniform.
- (5) The heat produced during manufacture of reclaimed rubber is less than that produced in the manufacture of new rubber.

*Disadvantages of reclaimed rubber :*

- (1) It has low tensile strength.
- (2) Its elasticity is low.
- (3) Its resistance to friction is low.

*Uses of reclaimed rubber :*

It is widely used for preparing rubber articles which are required for unimportant situations. It is used for mechanical equipments, tyres for vehicles, hose-pipes, etc.

**XV. Sheets for pitched roof coverings:**

The *two* varieties of commonly used sheets for pitched roof coverings are as follows:

- (1) Asbestos cement sheets
- (2) Galvanised iron sheets.

**(1) Asbestos cement sheets:**

Cement is mixed with about 15 per cent of asbestos fibres and the paste so formed is pressed under rollers with grooves or teeth. Thus sheets, commonly known as A. C. sheets, with a series of waves or corrugations are formed and they are used for factories, workshops, garages, big halls, etc. The corrugations help to increase strength and rigidity and they permit the easy flow of rain water. They are available under different trade names and in standard sizes. They are cheap, fire-resisting, light in weight and sound-proof.

**(2) Galvanised iron sheets:**

These sheets are prepared by pressing flat wrought-iron plates between rollers with grooves or teeth and then they are galvanised with a coat of zinc. These sheets are commonly known as G. I. sheets. The corrugations help to increase strength and rigidity and they permit easy flow of rain water. They are available in lengths varying from 120 cm to 360 cm and in widths varying from 60 cm to 90 cm. They are costly and do not offer resistance to fire and sound.

Table 15-6 shows the comparison between asbestos cement sheets and galvanised iron sheets.

**TABLE 15-6**  
COMPARISON BETWEEN A.C. SHEETS AND G.I. SHEETS

Sr.No.	A. C. Sheets	G. I. Sheets
1.	Breakable	Not breakable
2.	Cheap	Costly
3.	Do not corrode	Easily corroded
4.	Fire-resisting	Not fire-resisting
5.	Less noisy when something falls over them	Noisy when something falls over them
6.	Not affected by acids	Affected by acids
7.	Not much affected by temperature	Hot in summer and cold in winter
8.	Prepared from cement and asbestos fibres	Prepared from wrought-iron plates and then galvanised
9.	Sound-proof	Not sound-proof

## XVI. Solder:

Solder is an alloy which is used to join two or more pieces of metal. The melting point of solder is lower than the materials to be joined. The molten solder joins the pieces of metal and the process is known as *soldering*.

Solders are of the following *two* types:

- (1) Hard solders
- (2) Soft solders.

### (1) *Hard solders:*

A hard solder is an alloy of copper and zinc. It melts at a very high temperature. It is used for joining brass, copper, iron and steel. There are *two* varieties of hard solder, namely, brazing solder and silver solder. The term brazing is used to indicate soldering at high temperatures. The flux commonly used for hard solders is borax.

### (2) *Soft solders:*

A soft solder is an alloy of tin and lead. The most popular composition is 50% tin and 50% lead. It melts at a low temperature. It is used for joining copper, lead, tinned

iron, zinc, etc. There are *three* varieties of soft solder, namely, plumber solder, wireman's solder and tin liner's solder. The flux commonly used for soft solders is sal ammoniac.

### **XVII. Sound absorbent materials:**

Sound absorbent materials can be incorporated in building structures either in compressed state or in suspended state or in free state. In compressed state, they are provided between the load bearing panels of ceiling and floor. In suspended state, they are provided in the form of slabs fastened to ceiling so as to provide an air space. In free state, they are provided in non-compressed or loose manner.

According to the nature of absorbing sound, the sound absorbent materials can be classified as follows:

- (1) *Porous materials*: This type includes lightweight concrete with porous aggregate, foam glass, etc.
- (2) *Porous-cum-elastic materials*: This type includes porous materials with an elastic backing.
- (3) *Baffle materials*: This type includes thin panels from veneer, rigid wood fibre slabs, solid cardboard, etc.
- (4) *Perforated materials*: This type includes perforated panels and slabs. The holes may be of equal diameter or different diameters and they may be symmetrically arranged or located at random on the surface of panels or slabs.

Most of the common building materials absorb sound to a small extent and hence, for better acoustical requirement, some other materials are to be incorporated on the surfaces of the room. Such materials are known as sound absorbent materials and they help a great deal in making the room acoustically good. These materials are used for:

- (1) damping sound in ventilation installations;
- (2) developing special acoustic effects in TV, radio and film shooting studios, etc.;
- (3) facing interiors of premises which require a low noise level such as offices, restaurants, commercial centres, banks, etc.;
- (4) providing adequate acoustic in theatre halls, auditoriums, etc.

Various types of absorbent materials are available in the market under different trade names. The value of coefficient of absorption is supplied by the manufacturer. Following are some of the common types of absorbent materials:

(1) ***Hairfelt:***

This material was used by Prof. Sabin in his experimental works. The average value of coefficient of absorption of 25 mm thick hairfelt is 0.60.

(2) ***Acoustic plaster:***

This is also known as *fibrous plaster* and it includes granulated insulation material mixed with cement. If quantity of cement is more than required, the plaster will not have sufficient pores to become effective for acoustics. If quantity of cement is less, the plaster will not have enough strength. Thus the quantity of cement should be carefully decided. For thickness of 20 mm and density of  $0.10 \text{ g/cm}^3$ , the acoustic plaster possesses an absorbent coefficient of 0.30 at 500 cycles per second. Acoustic plaster boards are also available. They can be fixed on the wall and their coefficient of absorption varies from 0.15 to 0.30.

(3) ***Acoustical tiles:***

These are made in factory and sold under different trade names. The absorption of sound is uniform from tile to tile and they can be fixed easily. However, acoustical tiles are relatively costly than other absorbent materials. They are most suitable for rooms in which small area is available for acoustical treatment.

(4) ***Strawboard:***

This material can also be used as absorbent material. With a thickness of 13 mm and density of  $0.24 \text{ g/cm}^3$ , it possesses a coefficient of absorption of 0.30 at 500 cycles per second.

(5) ***Pulp boards:***

These are soft boards which are prepared from compressed pulp. They are cheap and can be fixed by ordinary panelling. The average value of coefficient of absorption is 0.17.

**(6) Compressed fibreboard:**

This material may be perforated or unperforated. The average coefficient of absorption for the former is 0.30 and for the latter is 0.52. It has a density of  $0.30 \text{ g/cm}^3$ .

**(7) Compressed wood particle board:**

This material is provided with perforations and it can be painted also. With a thickness of about 13 mm, the average coefficient of absorption is 0.40.

**(8) Perforated plywood:**

This material can be used by forming composite panels with mineral wool and cement asbestos or with mineral wool and hardboard. It is generally suspended from trusses. The average value of coefficient of absorption for the former composite panel is as high as 0.95 and for the latter composite panel, it is about 0.20.

**(9) Wood wool board:**

This material is generally used with a thickness of 25 mm and it has a density of  $0.40 \text{ g/cm}^3$ . The average value of coefficient of absorption is 0.20.

**(10) Quilts and mats:**

These are prepared from mineral wool or glass wool and are fixed in the form of acoustic blankets. The absorption coefficients of such quilts and mats depend on the thickness, density, perforations, mode of fixing, nature of backing and frequency of sound.

**XVIII. Tar:**

Tar is a dark black liquid with high viscosity. According to its source, tar is classified into the following *three* categories:

- (1) Coal tar
- (2) Mineral tar
- (3) Wood tar.

**(1) Coal tar:**

This variety of tar is prepared by heating coal in closed

iron vessels. The escaping gases are allowed to pass through tubes which are kept cool by circulation of water. Coal tar gets deposited in these tubes. It is usually obtained as a bye-product during the manufacture of coal gas. Coal tar is used for making macadam roads, preserving timber, etc.

(2) ***Mineral tar:***

This variety of tar is obtained by distilling bituminous shales. It contains less volatile matter.

(3) ***Wood tar:***

This variety of tar is obtained by the distillation of pines and similar other resinous trees. It contains creosote oil and hence, it possesses strong preservative property.

### **XIX. Turpentine:**

Turpentine is a transparent volatile liquid and it is thin like water. It is obtained by tapping juice or gum from certain varieties of pine trees. The juice is collected in spring time and it is heated in furnaces. The vapours formed during heating are collected and distilled to obtain turpentine.

Turpentine is mainly used as solvent for paints and varnishes. It also acts as a solvent for rubber. It is used for making printing ink, synthetic camphor, etc.

### **QUESTIONS**

1. What are abrasives? Explain them.
2. Mention the advantages and disadvantages of adhesives.
3. Describe various types of adhesives.
4. Enumerate properties and uses of asbestos.
5. What is asphalt? Give its classification.
6. Mention the forms of asphalt.
7. Enumerate properties and uses of asphalt.

8. Write short notes on:

- (1) Bitumen
- (2) Cork
- (3) Gypsum
- (4) Plaster of Paris
- (5) Solder
- (6) Turpentine
- (7) Greases
- (8) Blended oils
- (9) Mineral oils
- (10) Synthetic rubber
- (11) Foam rubber
- (12) Electric insulators
- (13) Acoustic plaster
- (14) Asbestos cement products.

9. Why are belts used? Give brief descriptions of materials employed to construct belts.

10. Discuss different types of fuels.

11. What is tar? Discuss its different categories.

12. What is dielectric strength? Mention the properties of a good electrical insulator.

13. Write a critical note on heat insulating materials.

14. Compare asbestos cement sheets with galvanised iron sheets.

15. Describe various sound absorbent materials.

16. Describe glues from synthetic resins. Mention their types.

17. Discuss the different forms of bitumen.

18. What is gypsum plaster? Mention its properties and uses.

19. What are the functions of a lubricant? Mention its types.

20. What are the characteristics of a good liquid lubricant?

21. Mention properties and uses of the common types of animal oils.

22. State properties and uses of the common types of vegetable oils.

23. Describe the methods of applying lubricants.

24. Describe the process of obtaining natural rubber.

25. What is vulcanization of rubber? Mention its effects.
26. Discuss the usual compounds which are used for natural rubber and synthetic rubber.
27. Suggest pigments for getting rubber of different colours.
28. Describe properties and uses of rubber.
29. What are the different forms of rubber?
30. What is meant by reclaimed rubber? State its advantages, disadvantages and uses.
31. Differentiate between the following:
  - (1) Rubber glues and starch glues
  - (2) Natural asphalt and residual asphalt
  - (3) Lake asphalt and rock asphalt
  - (4) Blown bitumen and cut-back bitumen
  - (5) Olive oil and palm oil
  - (6) Hardeners and plasticizers
  - (7) Smoked rubber and sponge rubber
  - (8) Hard solder and soft solder
  - (9) Conductors and non-conductors
  - (10) Strawboard and pulp boards.
32. Give reasons for the following:
  - (1) Gypsum is used in the manufacture of cement.
  - (2) Gypsum plaster cannot be adopted for damp conditions and external work.
  - (3) Viscosity of liquid lubricant should be proper.
  - (4) Certain compounds are added to rubber.
  - (5) Rubber possesses heavy scrap value.
  - (6) Crude rubber is to be vulcanized.
  - (7) Electrification is not a fundamental property of matter.
  - (8) The sheets for pitched roof coverings are provided with corrugations.
  - (9) Film shooting studios are to be provided with sound absorbent materials.

# Chapter 16

## PROPERTIES OF BUILDING MATERIALS

### **General:**

The fields of application of a particular building material are governed by the characteristics and various properties of that building material. Such properties may be classified into various categories such as physical, mechanical, chemical, magnetic, electric, etc. Out of all such properties, physical properties and mechanical properties are very important and in this chapter, definitions of the terms associated with these properties are given together with the explanation of importance of each property.

### **Physical properties:**

Following terms in connection with the physical properties of building materials are defined and explained:

- (1) Bulk density
- (2) Chemical resistance
- (3) Coefficient of softening
- (4) Density
- (5) Density index
- (6) Durability
- (7) Fire resistance
- (8) Frost resistance
- (9) Hygroscopicity
- (10) Porosity
- (11) Refractoriness
- (12) Spalling resistance
- (13) Specific heat
- (14) Thermal capacity
- (15) Thermal conductivity
- (16) Water absorption

- (17) Water permeability
- (18) Weathering resistance.

**(1) Bulk density:**

The term bulk density is used to mean the mass of a unit volume of material in its natural state, i.e., including pores and voids. It is obtained by finding out the ratio of mass of specimen to the volume of specimen in its natural state.

The technical properties of the material such as strength, heat, conductivity, etc. are greatly influenced by its bulk density and hence, the performance efficiency of a material will depend upon its bulk density. For most of the materials, bulk density is less than its density except for dense materials, liquids and materials obtained from molten masses.

Table 16-1 shows the bulk densities of some of the important building materials.

**TABLE 16-1**  
**BULK DENSITIES**

Sr.No.	Building material	Bulk density in kg/m
1.	Clay brick	1600 to 1800
2.	Dense limestone	1800 to 2400
3.	Granite	2500 to 2700
4.	Gravel	1400 to 1700
5.	Heavy concrete	1800 to 2500
6.	Light concrete	500 to 1800
7.	Mineral wool	200 to 400
8.	Pinewood	500 to 600
9.	Porous plastic materials	20 to 100
10.	Sand	1450 to 1650
11.	Steel	7850

**(2) Chemical resistance:**

The ability of material to withstand the action of acids, alkalis, gases and salt solutions is known as its chemical resistance.

This property is carefully examined while selecting material for sewer pipes, hydraulic engineering installations, sanitary facilities, etc.

### *(3) Coefficient of softening:*

The ratio of compressive strength of material saturated with water to that in dry state is known as the coefficient of softening.

The material such as glass and metal are not affected by the presence of water and their coefficient of softening is unity. On the other hand, the materials like clay easily lose their strength when soaked in water and hence their coefficient of softening is zero. The materials having coefficient of softening as equal to 0.8 or more are referred to as water-resisting materials. It is advisable to avoid the use of materials with coefficient of softening less than 0.8 for situations which are likely to be exposed permanently to the action of moisture.

### *(4) Density:*

The term density of a material is defined as the mass of a unit volume of homogeneous material. It is obtained by working out the ratio of mass of material to the volume of material in homogeneous state.

The physical properties of a material are greatly influenced by its density.

### *(5) Density index:*

The ratio of bulk density of a material to its density is known as its density index and it thus denotes the degree to which its volume is filled up with solid matter.

As there are practically no dense substances in nature, density index of most of the building materials is less than unity.

### *(6) Durability:*

The property of a material to resist the combined action of atmospheric and other factors is known as its durability.

The running or maintenance cost of a building will naturally depend upon the durability of the materials of which it is composed.

### *(7) Fire resistance:*

The term fire resistance is used to mean the ability of a

material to resist the action of high temperature without losing its load-bearing capacity, i.e., without substantial loss of strength or deformation in shape. This property of a material is of great importance in case of a fire and as the operation of fire-fighting is usually accompanied by water, this property of a material is tested by the combined actions of high temperature and water.

**(8) Frost resistance:**

The ability of a water-saturated material to resist repeated freezing and thawing without considerable decrease of mechanical strength or visible signs of failure is known as frost resistance. The frost resistance of a material depends upon the density of material and its degree of saturation with water. In general, dense materials are frost resistant. The porous materials whose pores are closed or filled with water to less than 90% of their volume are frost resistant.

**(9) Hygroscopicity:**

The property of a material to absorb water vapour from air is known as hygroscopicity and it is governed by the nature of substance involved, number of pores, air temperature, relative humidity, etc. The water-retaining or hydrophilic substances readily dissolve in water.

**(10) Porosity:**

The term porosity is used to indicate the degree by which the volume of a material is occupied by pores. It is expressed as a ratio of volume of pores to that of the specimen. Porosity of a material is indicative of its various properties such as strength, bulk density, water absorption, thermal conductivity, durability, etc.

**(11) Refractoriness:**

The ability of a material to withstand prolonged action of high temperature without melting or losing shape is known as its refractoriness.

**(12) Spalling resistance:**

The ability of a material to endure a certain number of cycles of sharp temperature variations without failing is known

as its spalling resistance and it mainly depends on the coefficients of linear expansion of its constituents.

**(13) Specific heat:**

The term specific heat is defined as the quantity of heat, expressed in kilocalories, required to heat 1 kg of material by 1°C. The specific heat of a material is to be considered when heat accumulation is to be taken into account. The specific heats of steel, stone and wood are as follows:

Steel	...	0.11	k cal/kg°C
Stone	...	0.18 to 0.22	,,
Wood	...	0.57 to 0.65	,,

**(14) Thermal capacity:**

The property of a material to absorb heat is known as its thermal capacity and it is worked out by the following equation:

$$T = \frac{H}{M (T_2 - T_1)}$$

where  $T$  = Thermal capacity in k cal/kg°C

$H$  = Quantity of heat required to increase the temperature of material from  $T_1$  to  $T_2$  in k cal

$M$  = Mass of material in kg

$T_1$  = Temperature of material before heating in °C

$T_2$  = Temperature of material after heating in °C.

**(15) Thermal conductivity:**

Thermal conductivity of a material is the amount of heat in kilocalories that will flow through unit area of the material with unit thickness in unit time when difference of temperature on its faces is also unity. The unit of thermal conductivity is k cal per m hr °C and it is usually denoted by K. Thermal conductivity of a material depends on its density, porosity, moisture content and temperature.

The term thermal resistivity of a material is used to mean the reciprocal of its thermal conductivity.

Thermal resistance of a material is equal to thermal resistivity multiplied by its thickness.

**(16) Water absorption:**

The ability of a material to absorb and retain water is known as its water absorption. The dry material is fully immersed in water and then the water absorption is worked out either as percentage of weight or percentage of volume of dry material. It mainly depends on the volume, size and shape of pores, present in the material.

**(17) Water permeability:**

The capacity of a material to allow water to pass through it under pressure is known as its water permeability and it is described as the quantity of water that will pass through the material in one hour at constant pressure, the cross-sectional area of the specimen being 1 cm<sup>2</sup>. Dense materials like glass, steel, etc. are water-proof or impervious to water.

**(18) Weathering resistance:**

The term weathering resistance is used to express the ability of a material to resist alternating wet and dry conditions without seriously affecting its shape and mechanical strength. It thus indicates the behaviour of materials when exposed to changing conditions of humidity.

**Mechanical properties:**

Following terms in connection with the mechanical properties of building materials are defined and explained:

- (1) Abrasion
- (2) Elasticity
- (3) Hardness
- (4) Impact strength
- (5) Plasticity
- (6) Strength
- (7) Wear.

**(1) Abrasion:**

The resistance to abrasion of a material is found out by dividing the difference in weights of specimens prior to and after abrasion with the area of abrasion.

**(2) Elasticity:**

When a load is applied to a material, there is change in its shape and dimension. The term elasticity is used to indicate the ability of a material to restore its initial form and dimensions after the load is removed.

**(3) Hardness:**

The ability of a material to resist penetration by a harder body is known as its hardness. It is a major factor in deciding the workability and use of a material for floors and road surfaces. Hardness of stone materials can be determined with the help of Mohs' scale of hardness. It is a list of ten materials arranged in the order of increasing hardness. The hardness of a material lies between the hardnesses of two materials, i.e., the one which scratches and the other which is scratched by the material to be tested. Table 16-1 shows the Mohs' scale of hardness.

**TABLE 16-2**  
**MOHS' SCALE OF HARDNESS**

Sr.No.	Material	Remarks
1.	Talcum	Readily scratched by finger nail.
2.	Rock-salt or gypsum	Scratched by finger nail.
3.	Calcite	Readily scratched by a steel knife.
4.	Fluorite	Scratched by a slightly pressed steel knife.
5.	Apatite	Scratched by a heavily pressed steel knife.
6.	Feldspar	Slightly scratches glass and is not scratched by a steel knife.
7.	Quartz	Readily scratches glass and is not scratched by a steel knife.
8.	Topaz	
9.	Corundum	
10.	Diamond	

**(4) Impact strength:**

The impact strength of a material is the quantity of work required to cause its failure per its unit volume. It thus indicates the toughness of a material and the materials are tested in an impact testing machine to determine their impact strength.

**(5) Plasticity:**

The term plasticity of a material is defined as its ability

to change its shape under load without cracking and to retain its shape after the removal of load.

**(6) Strength:**

The ability of a material to resist failure under the action of stresses caused by a load is known as its strength. The loads to which a material is commonly subjected to are compression, tension and bending. The corresponding strength is obtained by dividing the ultimate load with the cross-sectional area of the specimen.

**(7) Wear:**

The failure of a material under the combined actions of abrasion and impact is known as its wear. The wear resistance is usually expressed as a percentage of loss in weight and it is of great importance in deciding the suitability of a material for use of road surfaces, railway ballast, etc.

## QUESTIONS

1. Mention the list of important physical properties of a building material.
2. Explain the following terms:
  - (1) Coefficient of softening
  - (2) Spalling resistance
  - (3) Thermal capacity
  - (4) Thermal conductivity
  - (5) Wear
  - (6) Hardness
  - (7) Frost resistance
  - (8) Chemical resistance
  - (9) Bulk density
  - (10) Density
  - (11) Hygroscopicity
  - (12) Impact strength.

3. Define the following:
  - (1) Density index
  - (2) Refractoriness
  - (3) Water absorption
  - (4) Abrasion
  - (5) Strength
  - (6) Bulk density
  - (7) Porosity
  - (8) Thermal resistance.
4. Write short notes on the following:
  - (1) Durability
  - (2) Specific heat
  - (3) Water permeability
  - (4) Weathering resistance
  - (5) Fire resistance
  - (6) Elasticity.
5. What is hardness? Mention Mohs' scale of hardness.
6. Describe the important mechanical properties of a building material.
7. Mention the bulk densities of the following building materials:
  - (1) Granite
  - (2) Heavy concrete
  - (3) Mineral wool
  - (4) Sand
  - (5) Steel.
8. Differentiate between the following:
  - (1) Density and bulk density
  - (2) Fire resistance and frost resistance
  - (3) Porosity and hygroscopicity
  - (4) Thermal resistivity and thermal resistance
  - (5) Elasticity and plasticity.
9. Give reasons for the following:
  - (1) The property of fire resistance of a material is tested by the combined actions of high temperature and water.
  - (2) In general, dense materials are frost resistant.