

STRENGTH *of Materials*

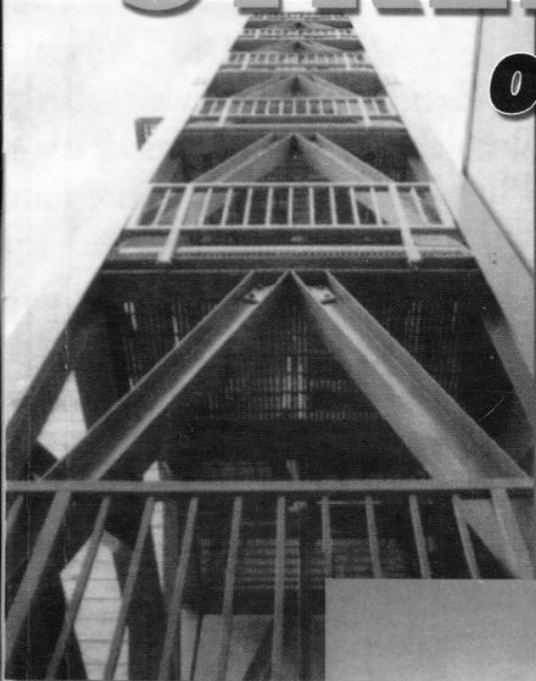

CONTENTS:

- Simple Stress
- Simple Strain
- Torsion
- Shear and Moment
in Beams
- Stresses in Beams
- Beam Deflections
- Restrained Beams
- Continuous Beams
- Combined Stresses
- Reinforced Beams
- Past Licensure Exams

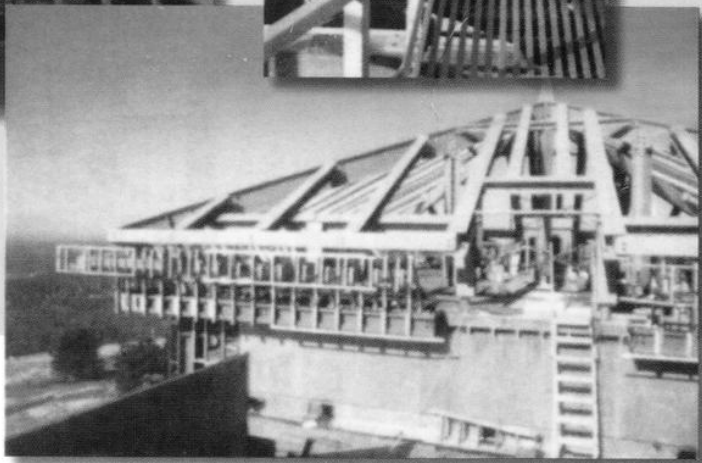

Besavilla

Solutions To Problems in STRENGTH OF MATERIALS

Copyright 1984 by Venancio I. Besavilla, Jr. All Rights Reserved. No part of this publication may be reproduced, stored in a retrieval system, or transmitted, in any form or by any means, electronic, mechanical, photocopying, recording, or otherwise, without the prior written permission of the publisher.

ISBN 971-8510-20-6



VIB Publisher, #2 Saint John Street, Don Bosco Village,
Punta Princesa, Cebu City. Tel. 272-2813

TABLE OF CONTENTS

	Page No.
Chapter 1 SIMPLE STRESS	
Analysis of Internal Forces	1-3
Simple Stress	3-8
Shearing Stress	8-15
Bearing Stress	15-22
Thin-walled Cylinders	22-30
Chapter 2 SIMPLE STRAIN	
Stress Strain Diagram	31-32
Axial Deformation	32-49
Poissons Ratio	50-52
Statistically Indeterminate Members	53-76
Thermal Stresses	77-102
Chapter 3 TORSION	
Torsional Stress	103-123
Flanged Bolt Couplings	123-130
Torsion of Thin Walled Tubes	131-132
Helical Springs	133-139
Chapter 4 SHEAR AND MOMENT IN BEAMS	
Shear and Moment Diagrams	140-162
Moving Loads	162-165
Chapter 5 STRESSES IN BEAMS	
Stresses in Beams	166-177
Economic Sections	178-181
Floor Framing	182-189
Unsymmetrical Beams	190-198
Shearing Stress	199-205
Flexure and Shear	205-211
Spacing of Rivets or Bolts	212-215
Chapter 6 BEAM DEFLECTIONS	
Double Integration Method	216-232
Moment Diagram By Parts	233-238
Deflection of Cantilever Beams	239-249

Chapter 7	RESTRAINED BEAMS	
	Redundant Supports in Propped and Restrained Beams	250-278
Chapter 8	CONTINUOUS BEAMS	
	Factors For The Three Moment Equations	279-283
	Application of Three Moment Equation	283-305
Chapter 9	COMBINED STRESSES	
	Combined Axial and Bending Stresses	306-319
	Application of Mohrs Circle	320-335
Chapter 10	REINFORCED BEAMS	
	Beams of Different Materials	336-346
	Shearing Stress and Deflections in Composite Beams	346-350
	Reinforced Concrete Beams	350-361

S.I. UNITS COMMONLY USED IN STRENGTH OF MATERIALS

To change lb. to Kg.

$$100 \text{ lb.} = \frac{100}{2.2}$$

$$100 \text{ lb.} = 45.45 \text{ kg.}$$

To change kg. to Newton

$$50 \text{ kg.} = 50 (9.807)$$

$$50 \text{ kg.} = 490.35 \text{ N}$$

To change psi to kg/cm^2

$$100 \text{ psi} = \frac{100}{2.2 (2.54) (2.54)}$$

$$100 \text{ psi} = 100 (0.07045)$$

$$100 \text{ psi} = 7.045 \text{ kg}/\text{cm}^2$$

To change kg/cm^2 to N/m^2 or Pa or KPa or MPa

$$500 \text{ kg}/\text{cm}^2 = 500 (9.807) (100)^2$$

$$500 \text{ kg}/\text{cm}^2 = 49035000 \text{ N}/\text{m}^2$$

$$500 \text{ kg}/\text{cm}^2 = 49035 \text{ KN}/\text{m}^2$$

$$500 \text{ kg}/\text{cm}^2 = 49035 \text{ KPa}$$

$$500 \text{ kg}/\text{cm}^2 = 49.035 \text{ MPa}$$

To change ft-lb to kg.m

$$2,000 \text{ ft-lb} = \frac{2000}{2.2 (3.28)}$$

$$2,000 \text{ ft-lb} = 2000 (0.1345) = 268.96 \text{ kg.m}$$

To change ft-lb to N.m

$$300 \text{ ft-lb} = \frac{300 (9.807)}{2.2 (3.28)}$$

$$300 \text{ ft-lb} = 300 (1.359)$$

$$300 \text{ ft-lb} = 407.72 \text{ N.m}$$

To change psf to kg/m^2

$$100 \text{ psf} = \frac{100 (3.28)^2}{2.2}$$

$$100 \text{ psf} = 489 \text{ kg}/\text{m}^2$$

To change psf to N/m^2

$$100 \text{ psf} = 100 (4.89) (9.807)$$

$$100 \text{ psf} = 4795.62 \text{ N/m}^2$$

To change psi to Pa

$$100 \text{ psi} = \frac{100 (9.807) (100)^2}{2.2 (2.54) (2.54)}$$

$$100 \text{ psi} = 100 (6909.49)$$

$$100 \text{ psi} = 690949 \text{ Pa} = 690949 \text{ N/m}^2$$

$$100 \text{ psi} = 690.949 \text{ KPa}$$

To change Joules to N.m

$$100 \text{ joules} = 100 \text{ N.m}$$

To change J/s to watts

$$100 \text{ joules/s} = 100 \text{ watts}$$

To change N.m/s to watts

$$100 \text{ N.m/s} = 100 \text{ watts}$$

To change N.m/s to hp

$$400 \text{ N.m/s} = 400 \text{ watts}$$

$$400 \text{ N.m/s} = \frac{400}{746} = 0.536 \text{ hp}$$

$$1 \text{ MPa} = 1 \text{ N/mm}^2$$

$$E_s = 200,000 \text{ MPa for steel}$$

Chapter 1

Simple Stress

PROBLEM 103.

Determine the largest weight W which can be supported by the two wires shown. The stresses in wires AB and AC are not to exceed 100 MPa and 150 MPa, respectively. The cross-sectional areas of the two wires are 400 mm^2 for wire AB and 200 mm^2 for wire AC .

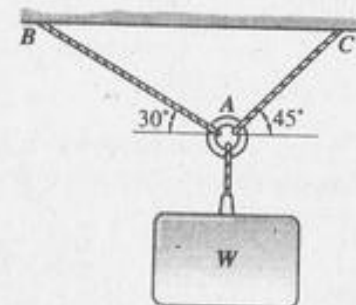

Solution:

Consider the FBD of joint A with x - axis through AB as shown

$$[\Sigma Y = 0]$$

$$AC \sin 75^\circ = W \sin 60^\circ$$

$$AC = 0.897W$$

$$[\Sigma H = 0]$$

$$AB \cos 30^\circ = AC \cos 45^\circ = (0.897W) \cos 45^\circ$$

$$AB = 0.732W$$

$$[P = AS]$$

for AC :

$$AC = (200)(150)$$

$$AC = 30,000 \text{ N}$$

$$0.897W = 30,000$$

$$W = 33,445 \text{ N}$$

for AB :

$$AB = 400(100)$$

$$AB = 40,000 \text{ N}$$

$$0.732W = 40,000$$

$$W = 54,645 \text{ N}$$

Therefore the largest safe weight $W = 33,445 \text{ N}$

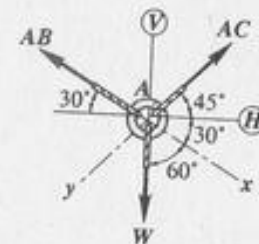

PROBLEM 104:

For the truss shown, calculate the stress in members DF, CE, and BD. The cross-sectional area of each member is 1200 mm^2 . Indicate tension (T) or compression (C).

Solution:

Consider FBD of whole truss.

$$|\Sigma M_A = 0|$$

$$R_F(10) = 100(4) + 200(7)$$

$$R_F = 180 \text{ kN}$$

Consider FBD of joint F

$$|\Sigma V = 0|$$

$$\frac{4}{5} DF = 180$$

$$DF = 225 \text{ kN (C)}$$

Pass the cutting plane a - a through members BD, CD, and CE and consider the FBD of right segment.

$$|\Sigma M_D = 0|$$

$$CE(4) = 180(3)$$

$$CE = 135 \text{ kN (T)}$$

Resolve BD into its components at B

$$|\Sigma M_C = 0|$$

$$\frac{3}{\sqrt{13}} BD(6) + 200(3) = 180(6)$$

$$BD = 96.15 \text{ kN (C)}$$

The stresses:

$$|S = \frac{P}{A}|$$

for DF:

$$S_{DF} = \frac{225(1000)}{1200}$$

$$S_{DF} = 187.5 \text{ MPa (C)}$$

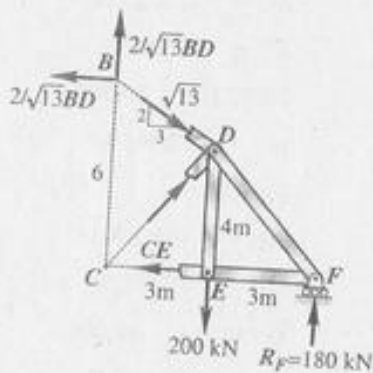
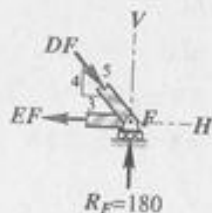
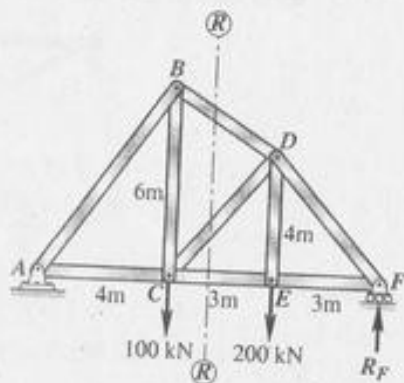

For CE:

$$S_{CE} = \frac{135(1000)}{1200}$$

$$S_{CE} = 112.5 \text{ MPa (T)}$$

For BD:

$$S_{BD} = \frac{96.15(1000)}{1200}$$

$$S_{BD} = 80.1 \text{ MPa (C)}$$

PROBLEM 105.

For the truss shown, determine the cross-sectional areas of bars BE, BF, and CF so that the stresses will not exceed 100 MN/m^2 in tension or 80 MN/m^2 in compression. A reduced stress in compression is specified to avoid the danger of buckling.

Solution:

Pass the cutting plane a - a through members

BE, BF, and CF, and consider the FBD of the right segment

$$|\Sigma M_B = 0|$$

$$CF(8) = 40(3) + 50(6)$$

$$CF = 52.5 \text{ kN (C)}$$

Resolve BE into its components at joint E

$$|\Sigma M_F = 0|$$

$$\frac{3}{5} BE(4) = 50(3)$$

$$BE = 62.5 \text{ kN (T)}$$

$$|\Sigma V = 0|$$

$$\frac{8}{\sqrt{13}} BF + \frac{4}{5}(62.5) = 40 + 50$$

$$\sqrt{13}$$

$$BF = 42.72 \text{ kN (T)}$$

The areas:

$$|A = \frac{P}{S}|$$

For CF:

$$A_{CF} = \frac{52.5(1000)}{80} = 656 \text{ mm}^2$$

For BE:

$$A_{BE} = \frac{62.5(1000)}{100} = 625 \text{ mm}^2$$

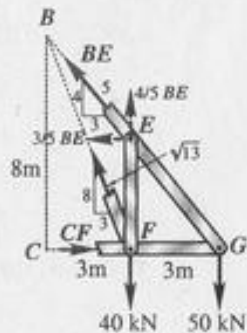
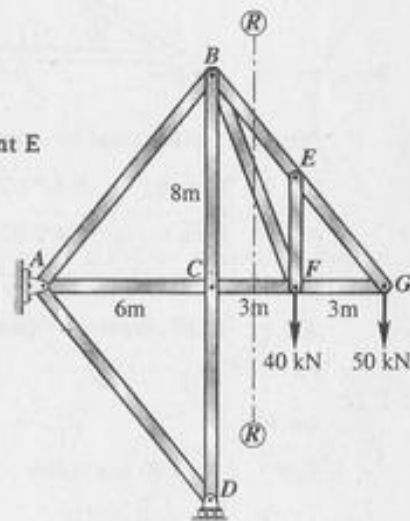

For BF:

$$A_{BF} = \frac{42.72(1000)}{100} = 427.2 \text{ mm}^2$$

PROBLEM 106.

The bars of the pin-connected frame shown are each 30 mm by 60 mm in section. Determine the maximum load P that can be applied so that the stresses will not exceed 100 MN/m^2 in tension or 80 MN/m^2 in compression.

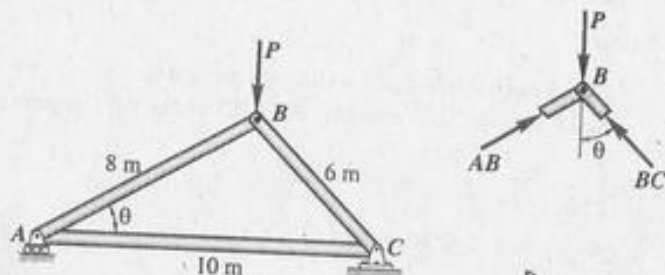

Solution:

Consider the FBD and force polygon for joint B

$$BC = P \cos \theta = 0.8 P \text{ (C)}$$

$$AB = P \sin \theta = 0.6 P \text{ (C)}$$

Consider FBD of joint A

$$AC = (0.6P) \cos \theta = (0.6P)(0.8) = 0.48P \text{ (T)}$$

$$[P = AS]$$

for AB:

$$0.6P = (30 \times 60)(80)$$

$$P = 240,000 \text{ N}$$

for BC:

$$0.8P = (30 \times 60)(80)$$

$$P = 180,000 \text{ N}$$

for AC:

$$0.48P = (30 \times 60)(100)$$

$$P = 375,000 \text{ N}$$

Therefore, the maximum safe load

$$P = 180,000 \text{ N} = 180 \text{ kN}$$

PROBLEM 107.

A cast-iron column supports an axial compressive load of 250 kN. Determine the inside diameter of the column if its outside diameter is 200 mm and the limiting compressive stress is 50 MPa.

Solution:

$$A = \frac{\pi}{4} (D_2^2 - D_1^2)$$

$$A = \frac{\pi}{4} (40,000 - D_1^2)$$

$$[P = AS]$$

$$250(1000) = \frac{\pi}{4} (40,000 - D_1^2)(50)$$

$$5000 = \frac{\pi}{4} (40,000 - D_1^2)$$

$$40,000 - D_1^2 = 6366.2$$

$$D_1 = 183.4 \text{ mm}$$

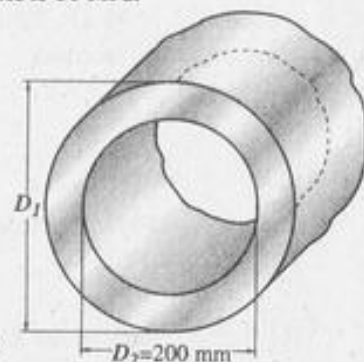

PROBLEM 108.

Determine the outside diameter of a hollow steel tube that will carry a tensile load of 500 kN at a stress of 140 MPa. Assume the wall thickness to be one-tenth of the outside diameter.

Solution:

$$[S = \frac{P}{A}]$$

$$140 = \frac{500(1000)}{A}$$

$$A = 3571.4 \text{ mm}^2$$

$$A = \frac{\pi}{4} (D^2 - (0.8D)^2) = \frac{\pi}{4} [D^2 - 0.64D^2]$$

$$3571.4 = \frac{\pi}{4} (0.36 D^2)$$

$$D = 112.4 \text{ mm}$$

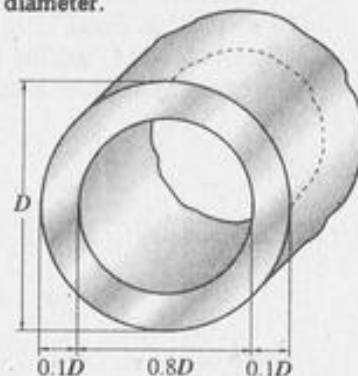

PROBLEM 109.

Part of the landing gear for a light plane is shown in the figure. Determine the compressive stress in the strut AB caused by a landing reaction $R = 20$ kN. Strut AB is inclined at 53.1° with BC. Neglect weights of the members.

Solution:

$$[\sum M_c = 0]$$

$$(P \sin 53.1)(450) = 20(650)$$

$$P = 36.125 \text{ kN}$$

$$A = \frac{\pi}{4} [(40)^2 - (30)^2]$$

$$A = 549.8 \text{ mm}^2$$

$$S = \frac{P}{A}$$

$$S = \frac{36.125 (1000)}{549.8}$$

$$S = 65.71 \text{ MPa}$$

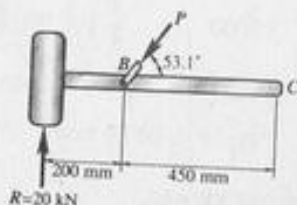
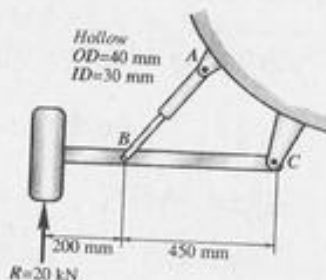

PROBLEM 110.

A steel tube is rigidly attached between an aluminum rod and a bronze rod as shown in the figure. Axial loads are applied at the positions indicated. Find the maximum value of P that will not exceed a stress in aluminum of 80 MPa, in steel of 150 MPa, or in bronze of 100 MPa.

Solution:

For Aluminum: $80 = \frac{P}{200}$

$$P = 16,000 \text{ N}$$

For Steel: $150 = \frac{2P}{400}$

$$P = 30,000 \text{ N}$$

For Bronze: $100 = \frac{4P}{500}$

$$P = 12,500 \text{ N (maximum safe value of } P)$$

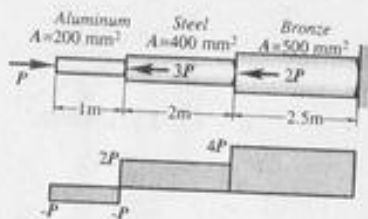

PROBLEM 111.

A homogeneous 150-kg bar AB carries a 2-kN force as shown in the figure. The bar is supported by a pin at B and a 10-mm-diameter cable CD. Determine the stress in the cable.

Solution:

$$W = 150(9.81)/1000 \text{ kN}$$

$$[\sum M_B = 0]$$

$$\frac{4}{5} T(3) = \frac{150(9.81)}{1000}(3) + 2(6)$$

$$T = 6.839 \text{ kN}$$

$$[S = \frac{P}{A}]$$

$$S = \frac{6.839 (1000)}{\frac{\pi}{4} (10)^2}$$

$$S = 87.08 \text{ MPa}$$

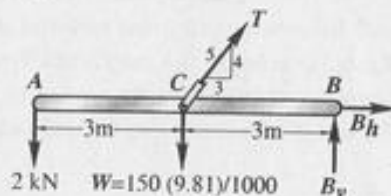
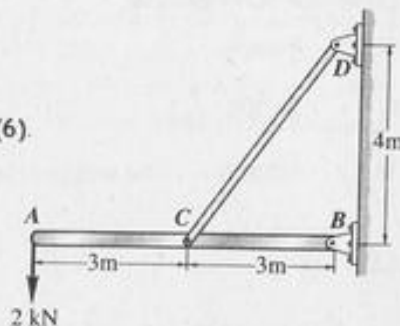

PROBLEM 112.

Determine the weight of the heaviest cylinder which can be placed in the position shown in the figure without exceeding a stress of 50 MN/m^2 in the cable BC. Neglect the weight of bar AB. The cross-sectional area of cable BC is 100 mm^2 .

Solution:

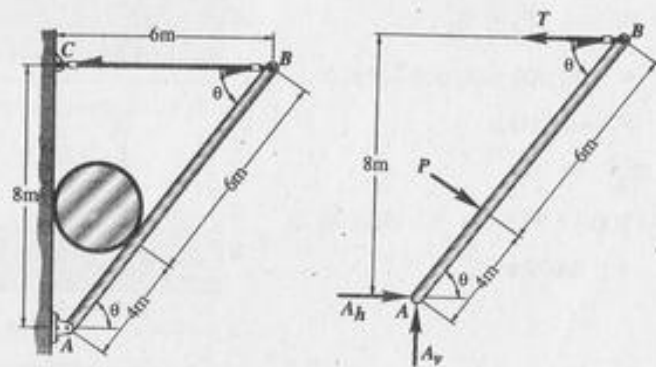

$$T = 50(100) = 5000 \text{ N}$$

$$[\sum M_A = 0]$$

$$P(4) = 5000(8)$$

$$P = 10,000 \text{ N}$$

Consider FBO of cylinder

$$W = P \cos \theta$$

$$W = 10,000 \left(\frac{6}{10}\right)$$

$$W = 6,000 \text{ N} - \text{the weight of heaviest cylinder}$$

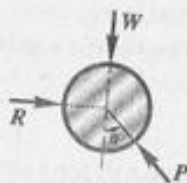

PROBLEM 113.

A 1000-kg homogeneous bar AB is suspended from two cables AC and BD; each with cross-sectional area 400 mm^2 , as shown in the figure. Determine the magnitude P and location x of the largest additional force which can be applied to the bar. The stresses in the cables AC and BD are limited to 100 MPa and 50 MPa, respectively.

Solution:

$$[P = AS]$$

$$T_A = (400)(100) = 40,000 \text{ N}$$

$$T_B = (400)(50) = 20,000 \text{ N}$$

$$W = (1000)(9.81) = 9810 \text{ N}$$

$$[\sum V = 0]$$

$$P + W = T_A + T_B$$

$$P = 40,000 + 20,000 - 9810$$

$$P = 50,190 \text{ N}$$

$$[\sum M_A = 0]$$

$$50,190(x) + 9810(1) = 20,000(2)$$

$$x = 0.602 \text{ m}$$

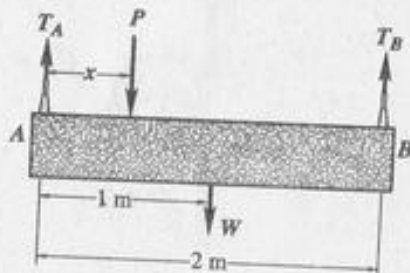
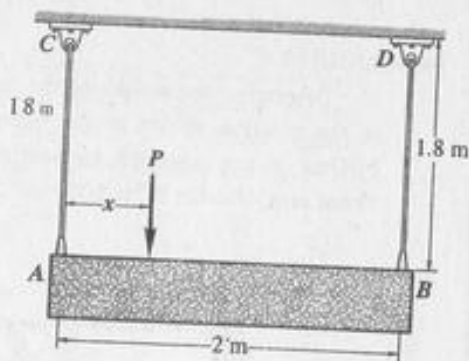

Shearing Stress

PROBLEM 114.

As in the figure shown, a hole is to be punched out of a plate having an ultimate shearing stress of 300 MPa. (a) If the compressive stress in the punch is limited to 400 MPa, determine the maximum thickness of plate from which a hole 100 mm in diameter can be punched. (b) If the plate is 100 mm thick, compute the smallest diameter hole which can be punched.

Solution:

$$(a) P = AS$$

$$P = \frac{\pi}{4} (100)^2 (400)$$

$$P = 1,000,000 \pi \text{ N}$$

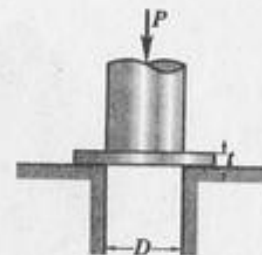

From shearing of plate,

$$A_s = \pi D t = 100 \pi t$$

$$P = A_s S_s$$

$$1,000,000 \pi = (100 \pi t) (300)$$

$$t = 33.33 \text{ mm}$$

$$(b) P = A_s S_s$$

$$P = (\pi D t) S_s$$

$$P = \pi D (10) (300)$$

$$P = 3,000 \pi D$$

from compression of punch.

$$P = AS$$

$$P = \frac{\pi}{4} D^2 (400)$$

$$P = 100 \pi D^2$$

$$100 \pi D^2 = 3000 \pi D$$

$$D = 30.0 \text{ mm}$$

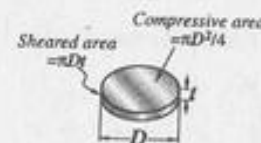

PROBLEM 115.

The end chord of a timber truss is framed into the bottom chord as shown in the figure. Neglecting friction, (a) compute dimension b if the allowable shearing stress is 900 kPa; and (b) determine dimension C so that the bearing stress does not exceed 7 MPa.

Solution:

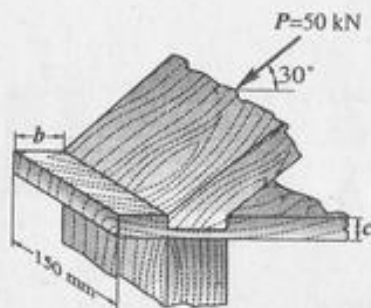

(a) From shearing

$$P_s = A_s S_s$$

$$P_s = P \cos 30^\circ$$

$$50 \cos 30^\circ (1000) = (150 b) (0.9)$$

$$b = 320.75 \text{ mm, say } 321 \text{ mm}$$

(b) From bearing

$$P_b = A_b S_b$$

$$50 \cos 30^\circ (1000) = (150 c) (7)$$

$$c = 41.24 \text{ mm, say } 42 \text{ mm}$$

PROBLEM 116.

In the landing gear described in Problem 109, the bolts at A and B are in single shear and the one at C is in double shear. Compute the required diameter of these bolts if the allowable shearing stress is 50 MPa.

Solution:

$$[\Sigma M_c = 0]$$

$$(P \sin 53.1^\circ)(450) = 20(650)$$

$$P = 36.125 \text{ kN}$$

$$[\Sigma V = 0]$$

$$C_v + 20 = 36.125 \sin 53.1^\circ$$

$$C_v = 8.889 \text{ kN}$$

$$[\Sigma H = 0]$$

$$C_H = 36.125 \cos 53.1^\circ$$

$$C_H = 21.690 \text{ kN}$$

$$R_c = \sqrt{C_H^2 + C_V^2}$$

$$= \sqrt{(21.69)^2 + (8.889)^2}$$

$$R_c = 23.44 \text{ kN}$$

for bolts at A and B (single shear):

$$P = A S$$

$$1000(36.125) = \left(\frac{\pi}{4} D^2\right) (50)$$

$$D = 30.33 \text{ mm}$$

for bolt at C (double shear):

$$23.44 (1000) = \left(\frac{\pi}{4} D^2\right) (50)^2$$

$$D = 17.3 \text{ mm}$$

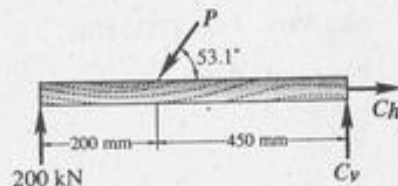

PROBLEM 117

A 750-mm pulley, loaded as shown, is keyed to a shaft of 50-mm diameter. Determine the width b of the 75-mm-long key if the allowable shearing stress is 70 MPa.

Solution:

$$[\sum M_o = 0]$$

$$P(25) + 6(375) = 10(375)$$

$$P = 60 \text{ kN}$$

$$P = AS$$

$$60(1000) = (75b)(70)$$

$$b = 11.4 \text{ mm}$$

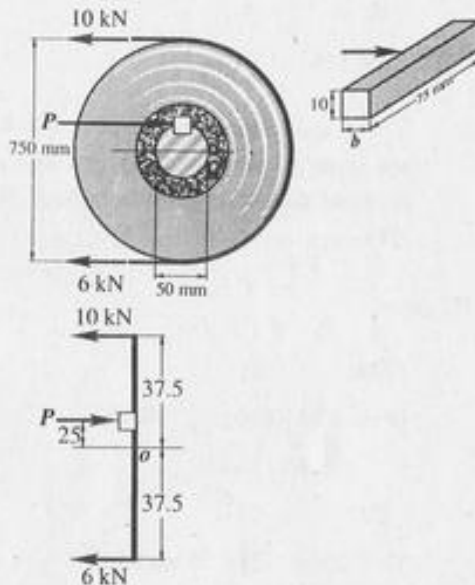

PROBLEM 118.

The bell crank shown is in equilibrium. (a) Determine the required diameter of the connecting rod AB if its axial stress is limited to 100 MN/m^2 . (b) Determine the shearing stress in the pin at D if its diameter is 20 mm.

Solution:

$$[\sum M_D = 0]$$

$$200P = 30 \sin 60^\circ (240)$$

$$P = 31.177 \text{ kN}$$

$$[\sum H = 0]$$

$$D_H = 31.177 + 30 \cos 60^\circ$$

$$D_H = 46.177 \text{ kN}$$

$$[\sum V = 0]$$

$$D_V = 30 \sin 60^\circ = 25.980 \text{ kN}$$

$$R_D = \sqrt{(46.177)^2 + (25.98)^2}$$

$$R_D = 52.984 \text{ kN}$$

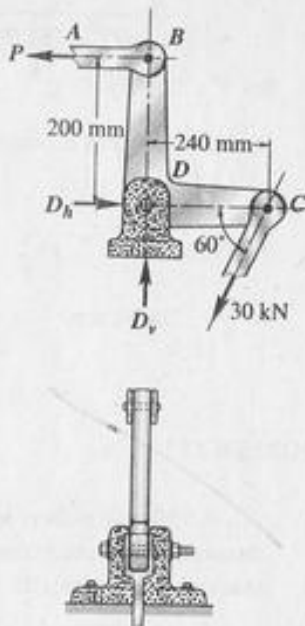

PROBLEM 119.

The mass of the homogenous bar AB shown in the figure is 2000 kg. The bar is supported by a pin at B and a smooth vertical surface at A. Determine the diameter of the smallest pin which can be used at B if its shear stress is limited to 60 MPa. The detail of the pin support at D is identical to that of the pin support at D shown in Problem 118.

Solution:

$$W = (2000)(9.81) = 19,620 \text{ N}$$

$$B_V = W = 19,620 \text{ N}$$

$$[\sum M_A = 0]$$

$$B_H(8) + 19,620(3) = 19,620(6)$$

$$B_H = 7357.5 \text{ N}$$

$$R_B = \sqrt{(7357.5)^2 + (19,620)^2}$$

$$R_B = 20,954 \text{ N}$$

$$[P = AS] \quad (\text{double shear})$$

$$20,954 = \left(\frac{\pi}{4} d^2\right) (60)(2)$$

$$d = 14.9 \text{ mm}$$

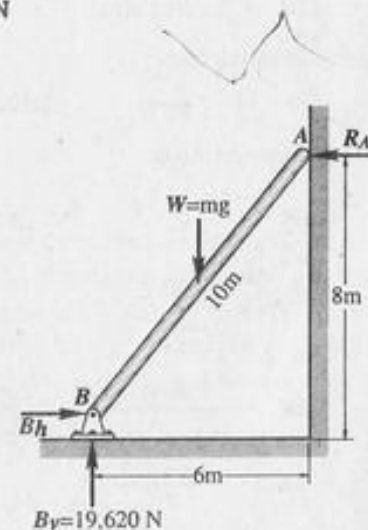

PROBLEM 120.

Two blocks of wood, 50 mm wide and 20 mm thick, are glued together as shown in the figure. (a) Using the free-body diagram concept, determine the shear load and from it the shearing stress in the glued joint if $P = 6000$ N. (b) Generalize the procedure of part (a) to show that the shearing stress on a plane inclined at an angle θ to a transverse section of area A is $S_s = P \sin 2\theta / 2A$.

Solution:

(a) Shearing force



$$V = P \cos 60^\circ$$

$$V = P \cos 60^\circ = 6000 \cos 60^\circ$$

$$V = 3000 \text{ N}$$

Shearing stress

$$S_s = \frac{V}{A}$$

$$S_s = \frac{3000}{\frac{50}{\sin 60^\circ} (20)}$$

$$S_s = 2.598 \text{ MPa}$$

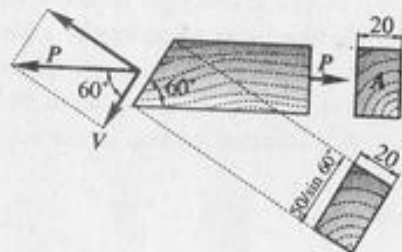

(b) Shearing force

$$V = P \sin \theta$$

Shearing stress

$$S_s = \frac{V}{A}$$

$$S_s = \frac{P \sin \theta}{\frac{A}{\cos \theta}}$$

$$S_s = \frac{P \sin \theta \cos \theta}{A} = \frac{P \sin 2\theta}{2A \cos \theta}$$

$$S_s = \frac{P \sin 2\theta}{2A}$$

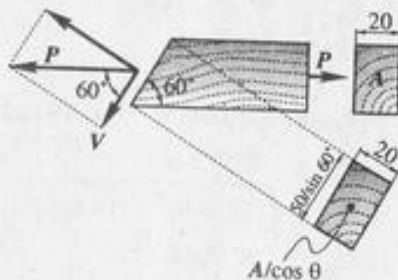

PROBLEM 121.

A rectangular piece of wood, 50 mm by 100 mm in cross-section, is used as a compression block as shown in the figure. Determine the maximum axial load P which can be safely applied to the block if the compressive stress in the wood is limited to 20 MN/m^2 and the shearing stress parallel to the grain is limited to 5 MN/m^2 . The grain makes an angle of 20° with the horizontal, as shown. (Hint: Use the results of Problem 120.)

Solution:

From compression

$$P = S A$$

$$P = (20)(50)(100)$$

$$P = 100,000 \text{ N}$$

From shear

$$S_s = \frac{P \sin 2\theta}{2A}$$

$$P = \frac{2A S_s}{\sin 2\theta}$$

$$P = \frac{2(50)(100)(5)}{\sin 40^\circ}$$

$$P = 7778.6 \text{ N}$$

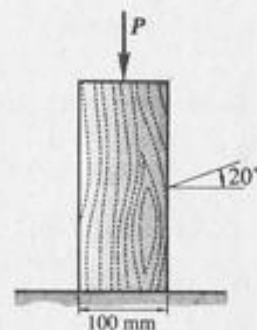

BEARING STRESS

PROBLEM 123.

In the figure shown, assume that a 20-mm-diameter rivet joins the plates which are each 100 mm wide. (a) If the allowable stresses are 140 MN/m^2 for bearing in the plate material and 80 MN/m^2 for shearing of the rivet, determine the minimum thickness of each plate. (b) Under the conditions specified in part (a), what is the largest average tensile stress in the plates.

Solution:

(a) From shearing of rivet

$$P = A_s S_s$$

$$P = \frac{\pi}{4} (20)^2 (80)$$

$$P = 25,133 \text{ N}$$

From bearing of plate

$$P = A_b S_b$$

$$P = (dt) S_b$$

$$25,133 = (20t)(140)$$

$$t = 8.98 \text{ mm}$$

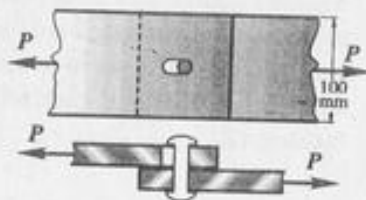

(b) Tensile stress in the plate

$$S = \frac{P}{A}$$

$$A = (100)(8.98) - (20)(8.98)$$

$$A = 718 \text{ mm}^2$$

$$S = \frac{25,133}{718}$$

$$S = 35.00 \text{ MPa}$$

**PROBLEM 124.**

The lap joint shown in the figure is fastened by three 20-mm-diameter rivets. Assuming that $P = 50 \text{ kN}$, determine (a) the shearing stress in each rivet, (b) the bearing stress in each plate, and (c) the maximum average tensile stress in each plate. Assume that the axial load P is distributed equally among the three rivets.

Solution:

(a) shearing stress in each rivet

$$S_s = \frac{P}{A_s}$$

$$S_s = \frac{(50)(1000)}{\frac{\pi}{4} (20)^2 (3)}$$

$$S_s = 53.05 \text{ MPa}$$

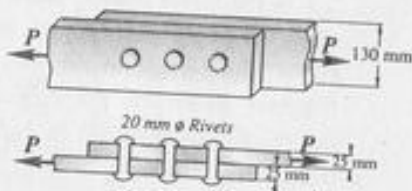

(b) bearing stress in each plate

$$S_b = \frac{P}{A_b}$$

$$= \frac{50(1000)}{(20)(25)(3)}$$

$$S_b = 33.33 \text{ MPa}$$

(c) Maximum tensile stress in each plate

$$S = \frac{P}{A_{\text{net}}}$$

$$A_{\text{net}} = (130 - 20)(25)$$

$$A_{\text{net}} = 2750 \text{ mm}^2$$

$$S = \frac{50(1000)}{2750}$$

$$S = 18.18 \text{ MPa}$$

PROBLEM 125.

For the lap joint in Problem 124, determine the maximum safe load P which may be applied if the shearing stress in the rivets is limited to 60 MPa, the bearing stress in the plates to 110 MPa, and the average tensile stress in the plate to 140 MPa.

Solution:

(a) From shearing of the rivets

$$P = A S$$

$$P = \frac{\pi}{4} (20)^2 (60)(3)$$

$$P = 56,549 \text{ N}$$

(b) From bearing of the plates

$$P = A_b S_b$$

$$P = (20)(25)(110)(3)$$

$$P = 165,000 \text{ N}$$

(c) From tension in the plates

$$P = A_{\text{net}} S$$

$$A_{\text{net}} = (130 - 20)(25) = 2750 \text{ mm}^2$$

$$P = (2750)(140)$$

$$P = 385,000 \text{ N}$$

Therefore, maximum safe load

$$P = 56,549 \text{ N} \quad (\text{shearing of the rivets govern})$$

PROBLEM 126.

In the clevis shown in the figure, determine the minimum bolt diameter and the minimum thickness of each yoke that will support a load $P = 55 \text{ kN}$ without exceeding a shearing stress of 70 MPa and a bearing stress of 140 MPa .

Solution:

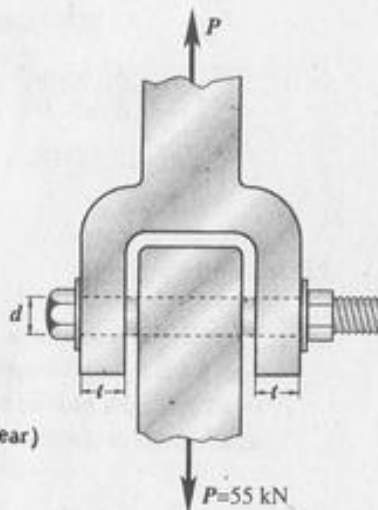

(a) Minimum diameter of bolt (double shear)

$$P = A S$$

$$55(1000) = \left(\frac{\pi}{4} d^2\right) (70)(2)$$

$$d = 22.37 \text{ mm}$$

(b) thickness of each yoke

$$P_b = A_b S_b$$

$$P_b = \frac{55}{2} = 27.5 \text{ kN (for each yoke)}$$

$$A_b = d t = 22.37 t$$

$$27.5(1000) = (22.37 t)(140)$$

$$t = 8.78 \text{ mm}$$



PROBLEM 127.

A 22.2-mm-diameter bolt having a diameter at the root of the threads of 18.6 mm is used to fasten two timbers as shown in the figure. The nut is tightened to cause a tensile load in the bolt of 34 kN. Determine (a) the shearing stress in the head of the bolt, (b) the shearing stress in the threads, and (c) the outside diameter of the washers if their inside diameter is 28 mm and the bearing stress is limited to 6 MPa.

Solution:

(a) shearing stress in the head of the bolt

$$S_s = \frac{P}{A_s}$$

$$S_s = \frac{34(1000)}{\pi (22.2)(12)}$$

$$S_s = 40.625 \text{ MPa}$$

(b) shearing stress in the threads

$$S_s = \frac{34(1000)}{\pi (18.6)(16)}$$

$$S_s = 36.366 \text{ MPa}$$

(c) outside diameter of washer

$$P_b = A_b S_b$$

$$34(1000) = \frac{\pi}{4} [d^2 - (28)^2] (6)$$

$$\frac{\pi}{4} [d^2 - (28)^2] = 5666.67$$

$$d = 89.44 \text{ mm}$$

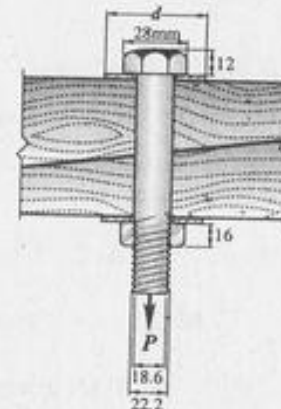

PROBLEM 128.

The figure shows a roof truss and the detail of the riveted connection at joint B. Using allowable stresses of $S_s = 70 \text{ MPa}$ and $S_b = 140 \text{ MPa}$, how many 19-mm-diameter rivets are required to fasten member BC to the gusset plate? Member BE? What is the largest average tensile or compressive stress in BC and BE?

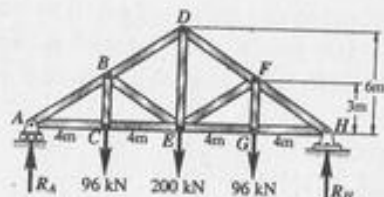
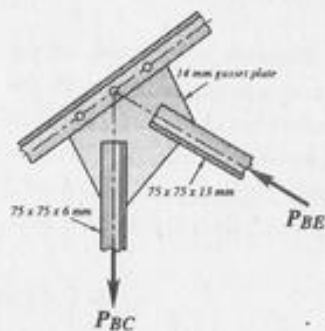

Solution:

Consider FBD of joint C

$$BC = 96 \text{ kN (Tension)}$$

Pass the cutting plane a-a through members BD, BE and BC, and consider left segment.

$$[\sum M_A = 0]$$

$$\frac{3}{5} BE (8) = 96(4)$$

$$BE = 80 \text{ kN (compression)}$$

for BC:

$$P = A_s S_s$$

$$96(1000) = \frac{\pi}{4} (19)^2 (70)(n)$$

$$n = 4.03 \text{ rivets}$$

$$P = A_b S_b$$

$$80,000 = (19)(13)(140)(n)$$

$$n = 2.31 \text{ rivets}$$

Use 5 rivets for member BE

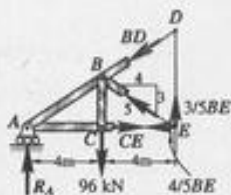
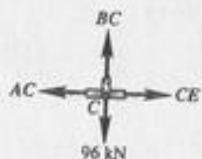

From Steel Manual (Appendix B of textbook)

$$\text{Area of } 75 \times 75 \times 6 \text{ mm} = 864 \text{ mm}^2$$

$$\text{Area of } 75 \times 75 \times 13 \text{ mm} = 1780 \text{ mm}^2$$

Tensile stress in BC:

$$S_t = \frac{P}{A_{\text{net}}}$$

$$A_{\text{net}} = 864 - (19)(6) = 750 \text{ mm}^2$$

$$S = \frac{96(1000)}{750}$$

$$S = 128 \text{ MPa}$$

Compressive stress in BE:

$$S_c = \frac{P}{A}$$

$$S_c = \frac{80(1000)}{1780}$$

$$S_c = 44.9 \text{ MPa}$$

PROBLEM 129.

Repeat Problem 128 if the rivet diameter is 22 mm and all other data remain unchanged.

Solution:

For member BC:

$$P_{BC} = 96,000 \text{ N (tension)}$$

$$P = A_s S_s$$

$$96,000 = \frac{\pi}{4} (22)^2 (70)(n)$$

$$n = 3.61 \text{ rivets}$$

$$P = A_b S_b$$

$$96,000 = (22)(6)(140)(n)$$

$$n = 5.19$$

Use 6 rivets for member BC

Tensile stress

$$S_t = \frac{P}{A_{\text{net}}}$$

$$A_{\text{net}} = 864 - (22)(6)$$

$$A_{\text{net}} = 732 \text{ mm}^2$$

$$S_t = \frac{96,000}{732}$$

$$S_t = 131.15 \text{ MPa}$$

For member BE:

$$P_{\text{BE}} = 80,000 \text{ N (compression)}$$

$$P = A_s S_s$$

$$80,000 = \frac{\pi}{4} (22)^2 (70)(n)$$

$$n = 3.01 \text{ rivets}$$

$$P = A_b S_b$$

$$80,000 = (22)(13)(140)(n)$$

$$n = 1.998 \text{ rivets}$$

Use 4 rivets for BE

Compressive stress:

$$S_c = \frac{P}{A}$$

$$S_c = \frac{80,000}{1780}$$

$$S_c = 44.94 \text{ MPa}$$

THIN-WALLED CYLINDERS

PROBLEM 131.

Show that the stress in a thin-walled spherical shell of diameter D and wall thickness t subjected to internal pressure P is given by $S = PD/4t$.

Solution:

$$F = pA = p \frac{\pi D^2}{4}$$

$$F = P = p \frac{\pi D^2}{4}$$

$$S = \frac{P}{A}$$

$$S = \frac{p \frac{\pi D^2}{4}}{\pi D t}$$

$$S = \frac{p D}{4 t}$$

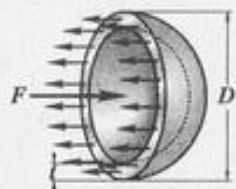

PROBLEM 132.

A cylindrical pressure vessel is fabricated from steel plates which have a thickness of 20 mm. The diameter of the pressure vessel is 500 mm and its length is 3 m. Determine the maximum internal pressure which can be applied if the stress in the steel is limited to 140 MPa.

Solution:

$$F = pDL$$

$$F = p(500)(3000)$$

$$F = 1,500,000 p \text{ N}$$

$$2T = F = 1,500,000 p$$

$$T = 750,000 p$$

$$S = \frac{P}{A}$$

$$140 = \frac{750,000 p}{(20)(3000)}$$

$$p = 11.2 \text{ MPa}$$

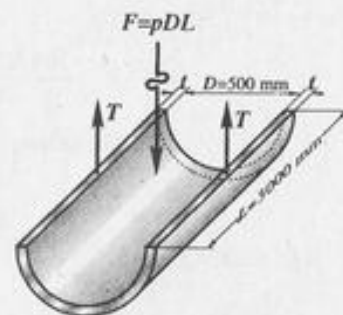

PROBLEM 133.

Find the limiting peripheral velocity of a rotating steel ring if the allowable stress is 140 MN/m^2 and the mass density of steel is 7850 kg/m^3 . At what angular velocity will the stress reach 200 MN/m^2 if the mean radius is 250 mm ?

Solution:

$$(a) F = m \bar{r} w^2$$

$$F = (pV) \frac{2r_c}{\pi} \left(\frac{v}{r_c}\right)^2$$

$$F = (p\pi A r_c) \frac{2r_c}{\pi} \frac{v^2}{r_c^2}$$

$$F = 2pAv^2$$

$$P = \frac{F}{2} = pAv^2$$

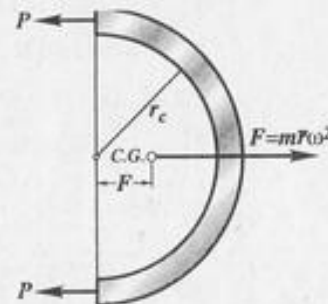

$$S = \frac{P}{\bar{A}}$$

$$S = \frac{p Av^2}{A} = p v^2$$

Substitute values,

$$140 \times 10^6 = 7850 v^2$$

$$v = 133.55 \text{ m/sec}$$

$$(b) 200 \times 10^6 = 7850 v^2$$

$$v = 159.62 \text{ m/sec}$$

$$v = r_c w$$

$$w = \frac{v}{r_c} = \frac{159.62 (1000)}{250}$$

$$w = 638.47 \text{ rad/sec}$$

PROBLEM 134.

A water tank is 8 m in diameter and 12 m high. If the tank is to be completely filled, determine the minimum thickness of the tank plating if the stress is limited to 40 MPa.

Solution:

$$F = w h A$$

$$F = 9810(12)(8)(0.001)$$

$$F = 941.76 \text{ N}$$

$$2P = F = 941.76$$

$$P = 470.88 \text{ N}$$

$$S = \frac{P}{\bar{A}}$$

$$40 = \frac{470.88}{(t)(1)}$$

$$t = 11.77 \text{ mm}$$

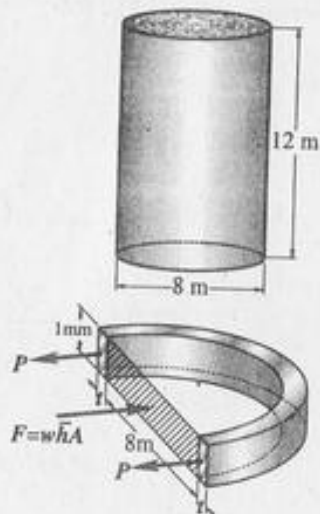

PROBLEM 135.

The strength per meter of the longitudinal joint in the figure is 480 kN, whereas for the girth joint it is 200 kN. Determine the maximum diameter of the cylindrical tank if the internal pressure is 1.5 MN/m².

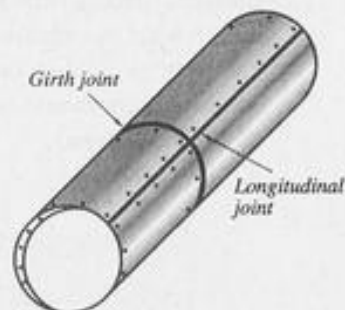

Solution:

For longitudinal joint

$$F = 2T$$

$$PDL = 2T$$

$$(1.5 \times 10^6)(D)(1) = 2(480)(1000)$$

$$D = 0.64 \text{ m}$$

For girth joint,

$$F = p \frac{\pi D^2}{4}$$

$$T = (\pi D)(200)(1000) \text{ N}$$

$$F = T$$

$$p \frac{\pi D^2}{4} = (\pi D)(200,000)$$

$$(1.5 \times 10^6) \frac{D}{4} = 200,000$$

$$D = 0.53 \text{ m}$$

$$\text{Use } D = 0.53 \text{ m (maximum diameter)}$$

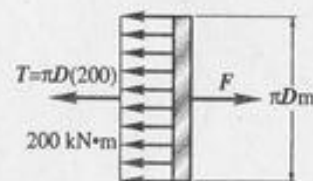
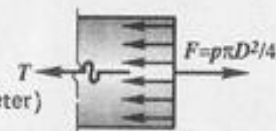
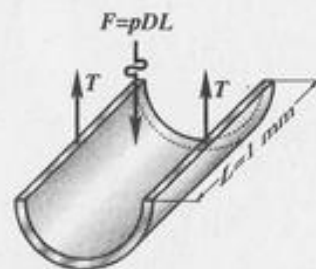

PROBLEM 136.

A pipe carrying steam at 3.5 MPa has an outside diameter of 450 mm and a wall thickness of 10 mm. A gasket is inserted between the flange at one end of the pipe and a flat plate used to cap the end. How many 40-mm diameter bolts must be used to hold the cap on if the allowable stress in the bolts is 80 MPa, of which 55 MPa is the initial stress? What circumferential stress is developed in the pipe? Why is it necessary to tighten the bolts initially, and what will happen if the steam pressure should cause the stress in the bolts to be twice the value of the initial stress?

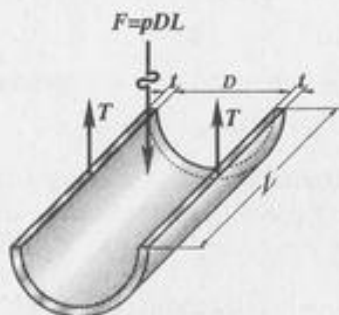
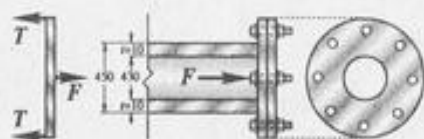

Solution:

$$(a) F = (3.5) \left(\frac{\pi}{4} \right) (430)^2$$

$$F = 508,270 \text{ N}$$

Bolt stress due to steam pressure

$$S = \text{Final stress} - \text{Initial stress}$$

$$S = 80 - 55$$

$$S = 25 \text{ MPa}$$

$$T = AS$$

$$T = \frac{\pi}{4} (40)^2 (25)$$

$$T = 31,416 \text{ N}$$

$$T_n = F$$

$$n = \frac{508,270}{31,416}$$

$$n = 16.2$$

$$\text{Use } n = 17 \text{ bolts}$$

$$(b) 2T = F = PDL$$

$$T = \frac{PDL}{2}$$

$$S = \frac{T}{A}$$

$$S = \frac{PDL}{2(tL)}$$

$$S = \frac{PD}{2t}$$

$$S = \frac{(3.5)(430)}{2(10)}$$

$$S = 75.25 \text{ MPa}$$

PROBLEM 137.

A spiral-riveted penstock 1.5 m in diameter is made of steel plate 10 mm thick. The pitch of the spiral or helix is 3 m. The spiral seam is a single-riveted lap joint consisting of 20-mm-diameter rivets. Using $S_s = 70 \text{ MPa}$ and $S_b = 140 \text{ MPa}$, determine the spacing of the rivets along the seam for a water pressure of 1.25 MPa. Neglect end thrust. What is the circumferential stress?

Solution:

Shearing of rivets

$$T = A_s S_s$$

$$T = \frac{\pi}{4} (20)^2 (70)$$

$$T = 21,991 \text{ N}$$

Bearing of rivets

$$T = A_b S_b$$

$$T = (10)(20)(140)$$

$$T = 28,000 \text{ N}$$

$$\text{Use } T = 21,991 \text{ N}$$

$$2T = F = PDL$$

$$2(21,991) = (1.25)(1500)(L)$$

$$L = 23.46 \text{ mm}$$

$$\frac{S}{L} = \frac{5.586}{3}$$

$$S = \frac{5.586(23.46)}{3}$$

$$S = 43.7 \text{ mm}$$

Circumferential stress:

$$T = A S_t$$

$$21,991 = (10)(23.46) S_t$$

$$S_t = 93.74 \text{ MPa}$$

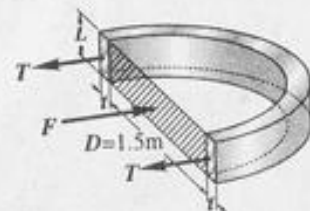
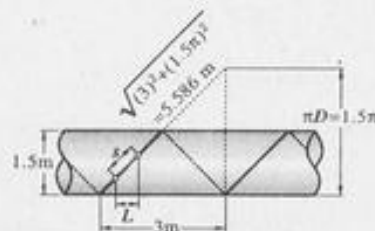

PROBLEM 138.

Repeat Problem 137, using a 2-m-diameter penstock fastened with 30-mm-diameter rivets, with all other data remaining unchanged.

Solution:

Shearing of rivets

$$T = A_s S_s$$

$$T = \frac{\pi}{4} (30)^2 (70)$$

$$T = 49,490 \text{ N}$$

Bearing of rivets

$$T = A_b S_b$$

$$T = (30)(10)(140)$$

$$T = 42,000 \text{ N}$$

$$\text{Use } T = 42,000 \text{ N}$$

$$2T = F = p DL$$

$$2(42,000) = (1.25)(2000)L$$

$$L = 33.6 \text{ mm}$$

$$\frac{S}{L} = \frac{6.963}{3}$$

$$S = \frac{(6.963)(33.6)}{3}$$

$$S = 77.99 \text{ mm}$$

$$\text{say } S = 78 \text{ mm}$$

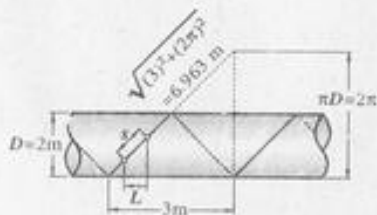

PROBLEM 139.

The tank shown in the figure is fabricated from 10-mm steel plate. Determine the maximum longitudinal and circumferential stresses caused by an internal pressure of 1.2 MPa.

Solution:



Longitudinal stress

$$F = p A$$

$$F = (1.2) [(400)(600) + \frac{\pi}{4} (400)^2]$$

$$F = 438,796 \text{ N}$$

$$F = A S_e$$

$$438,796 = [(600)(2)(10) + (400\pi)(10)] S_e$$

$$S_e = 17.86 \text{ MPa}$$

Circumferential stress

$$F = (1.2)(1000 L)$$

$$F = 1200 L \text{ N}$$

$$2T = F = 1200 L$$

$$T = 600 L \text{ N}$$

$$T = A S_t$$

$$600L = (10 L)(S_t)$$

$$S_t = 60 \text{ MPa}$$

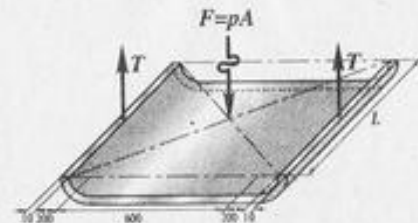

PROBLEM 140.

The tank shown in Problem 139 is fabricated from steel plate. Determine the minimum thickness of plate which may be used if the stress is limited to 40 MN/m^2 and the internal pressure is 1.5 MN/m^2 .

Solution:

From Problem 139, circumferential stress is critical, so it governs the thickness of the plate.

$$F = pA$$

$$F = (1.5)(1000 L)$$

$$F = 1500 L N$$

$$2T = F = 1500 L$$

$$T = 750 L$$

$$T = A S t$$

$$750 L = (t L)(40)$$

$$t = 18.75 \text{ mm}$$

Simple Strain

PROBLEM 203.

During a stress-strain test, the unit deformation at a stress of 35 MN/m^2 was observed to be $167 \times 10^{-6} \text{ m/m}$ and at a stress of 140 MN/m^2 it was $667 \times 10^{-6} \text{ m/m}$. If the proportional limit was 200 MN/m^2 , what is the modulus of elasticity? What is the strain corresponding to a stress of 80 MN/m^2 ? Would these results be valid if the proportional limit were 150 MN/m^2 ?

Solution:

$$\Delta E = (667 - 167) \times 10^{-6}$$

$$\Delta E = 500 \times 10^{-6} \text{ m/m}$$

$$\Delta S = (140 - 35)$$

$$\Delta S = 105 \text{ MN/m}^2$$

$$E = \frac{\Delta S}{\Delta E}$$

$$E = \frac{105 \times 10^6}{500 \times 10^{-6}}$$

$$E = 210 \times 10^9 \text{ N/m}^2$$

$$S = E \epsilon$$

$$80 \times 10^6 = (210 \times 10^9) \epsilon$$

$$\epsilon = 380.95 \times 10^{-6} \text{ m/m}$$

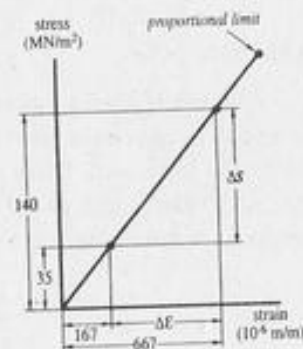

PROBLEM 204.

A uniform bar of length L , cross-sectional area A , and a unit mass μ is suspended vertically from one end. Show that its total elongation is $y = \rho g L^2 / 2E$. If the total mass of the bar is M , show also that $y = Mg / 2AE$.

Solution:

$$y = \frac{PL}{AE}$$

$$dy = \frac{p g A x dx}{AE}$$

$$y = \frac{p g}{E} \int_0^L x dx$$

$$y = \frac{p g}{E} \left[\frac{x^2}{2} \right]_0^L$$

$$y = \frac{p g L^2}{2 E}$$

$$M = p A L$$

$$y = \frac{p g L^2}{2 E} \times \frac{M}{p A L}$$

$$y = \frac{M g L}{2 A E}$$

PROBLEM 205.

A steel rod having a cross-sectional area of 300 mm^2 and a length of 150 m is suspended vertically from one end. It supports a load of 20 kN at the lower end. If the unit mass of steel is 7850 kg/m^3 and $E = 200 \times 10^3 \text{ MN/m}^2$, find the total elongation of the rod. (Hint: Use the results of Problem 204.)

Solution:

$$Y = Y_1 + Y_2$$

$$Y_1 = \frac{p g L^2}{2 E}$$

$$Y_1 = \frac{7850(9.81)(150)^2(1000)}{2(200 \times 10^9)}$$

$$Y_1 = 4.33 \text{ mm}$$

$$Y_2 = \frac{PL}{AE}$$

$$Y_2 = \frac{(20)(1000)(150)(1000)}{(300)(200 \times 10^3)}$$

$$Y_2 = 50 \text{ mm}$$

$$Y = 4.33 + 50$$

$$Y = 54.33 \text{ mm}$$

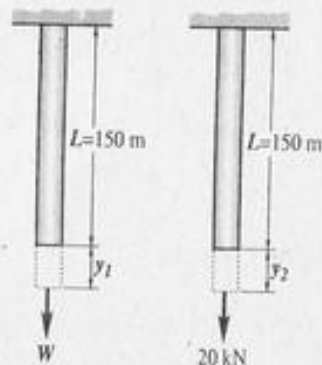
PROBLEM 206.

A steel wire 10 m long hanging vertically supports a tensile load of 2000 N . Neglecting the weight of the wire, determine the required diameter if the stress is not to exceed 140 MPa and the total elongation is not to exceed 5 mm . Assume $E = 200 \text{ GPa}$.

Solution:

from stress

$$p = \frac{P}{A}$$

$$200 = \left(\frac{\pi}{4} d^2 \right) (140)$$

$$d = 4.26 \text{ mm}$$

from elongation,

$$y = \frac{PL}{AE}$$

$$5 = \frac{(2000)(10)(1000)}{\left(\frac{\pi}{4} d^2 \right) (200 \times 10^3)}$$

$$d = 5.05 \text{ mm}$$

$$\text{Use } d = 5.05 \text{ mm}$$



PROBLEM 207.

A steel tire, 10 mm thick, 80 mm wide, and of 1500 mm inside diameter, is heated and shrunk onto a steel wheel 1500.5 mm in diameter. If the coefficient of static friction is 0.30, what torque is required to twist the tire relative to the wheel. Use $E = 200$ GPa.

Solution:

$$y = \frac{PL}{AE}$$

$$y = \pi (1500.5 - 1500)$$

$$y = 1.571 \text{ mm}$$

$$p = T$$

$$L = 1500 \pi \text{ mm}$$

$$A = (80)(10) \text{ mm}^2$$

$$1.571 = \frac{(T)(1500 \pi)}{(800)(200 \times 10^3)}$$

$$T = 53,333 \text{ N}$$

$$2T = P = pDL$$

$$2(53,333) = p(1500)(80)$$

$$p = 0.889 \text{ MPa}$$

$$N = (0.889)(\pi)(1500)(80)$$

$$N = 335,101 \text{ N}$$

$$F = \mu N$$

$$F = 0.30(335,101)$$

$$F = 100,530 \text{ N} = 100.5 \text{ kN}$$

$$\text{Torque} = F(0.750)$$

$$\text{Torque} = (100.5)(0.750)$$

$$\text{Torque} = 75.4 \text{ kN} \cdot \text{m}$$

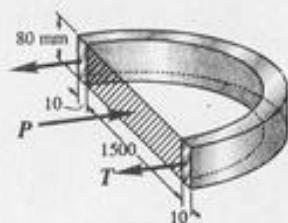
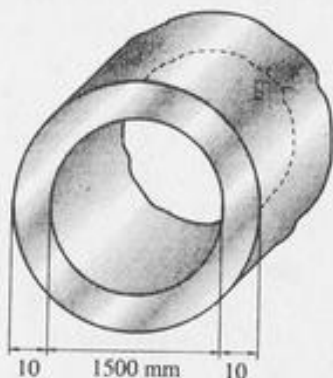

PROBLEM 208.

An aluminum bar having a cross-sectional area of 160 mm^2 carries the axial loads at the positions shown in the figure. If $E = 70$ EPa, compute the total deformation of the bar. Assume that the bar is suitably braced to prevent buckling.

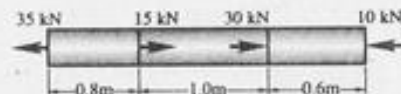

Solution:

$$y = \frac{PL}{AE}$$

$$y_1 = \frac{(35000)(800)}{(160)(70 \times 10^3)}$$

$$y_1 = 2.5 \text{ mm}$$

$$y_2 = \frac{(20,000)(1000)}{(160)(70 \times 10^3)}$$

$$y_2 = 1.786 \text{ mm}$$

$$y_3 = \frac{(10,000)(600)}{(160)(70 \times 10^3)}$$

$$y_3 = 0.536 \text{ mm}$$

Total deformation

$$y = y_1 + y_2 - y_3$$

$$y = 2.5 + 1.786 - 0.536$$

$$y = 3.75 \text{ mm (elongation)}$$

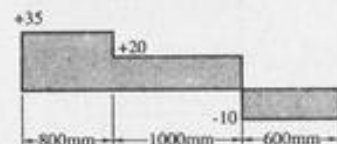

PROBLEM 209.

Solve Problem 208 if the magnitudes of the loads at the ends are interchanged, i.e., if the load at the left end is 10 kN and that at the right end is 35 kN.

Solution:

$$y = \frac{PL}{AE}$$

$$y_1 = \frac{(10,000)(800)}{(160)(70 \times 10^3)}$$

$$y_1 = 0.714 \text{ mm}$$

$$y_2 = \frac{(500)(1000)}{(160)(70 \times 10^3)}$$

$$y_2 = 0.446 \text{ mm}$$

$$y_3 = \frac{(35,000)(600)}{(160)(70 \times 10^3)}$$

$$y_3 = 1.875 \text{ mm}$$

Total deformation,

$$y = y_1 - y_2 - y_3$$

$$y = 0.714 - 0.446 - 1.875$$

$$y = 1.607 \text{ mm (contraction)}$$

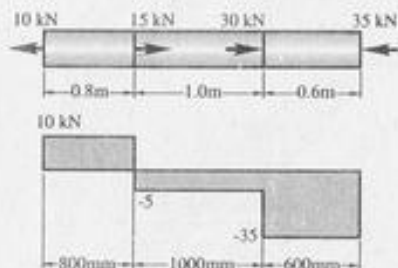

PROBLEM 210.

An aluminum tube is fastened between a steel rod and a bronze rod as shown. Axial loads are applied at the positions indicated. Find the value of P that will not exceed a maximum overall deformation of 2 mm or a stress in the steel of 140 MN/m^2 , in the aluminum of 80 MN/m^2 , or in the bronze of 120 MN/m^2 . Assume that the assembly is suitably braced to prevent buckling and that $E_s = 200 \times 10^3 \text{ MN/m}^2$, $E_a = 70 \times 10^3 \text{ MN/m}^2$, and $E_b = 83 \times 10^3 \text{ MN/m}^2$.

Solution:

From total deformation:

$$y = y_s$$

$$y = y_s - y_b - y_a$$

$$y_s = \frac{(2P)(800)}{(300)(200 \times 10^3)}$$

$$y_s = (2.67 \times 10^{-5}) P$$

$$y_b = \frac{(3P)(600)}{(450)(83 \times 10^3)}$$

$$y_b = (4.82 \times 10^{-5}) P$$

$$y_a = \frac{(2P)(1000)}{(600)(70 \times 10^3)}$$

$$y_a = (4.76 \times 10^{-5}) P$$

$$y = (2.67 \times 10^{-5}) P - (4.82 \times 10^{-5}) P - (4.76 \times 10^{-5}) P$$

$$y = -(6.91 \times 10^{-5}) P \quad (\text{contraction})$$

$$\text{allowable } y = 2 \text{ mm}$$

$$2 = (6.91 \times 10^{-5}) P$$

$$P = 28,944 \text{ N}$$

From strength of each member:

$$[s = AS]$$

for Bronze:

$$P_b = A_b S_b$$

$$3P = (450)(120)$$

$$P = 18,000 \text{ N}$$

for aluminum:

$$P_a = A_a S_a$$

$$2P = (600)(80)$$

$$P = 24,000 \text{ N}$$

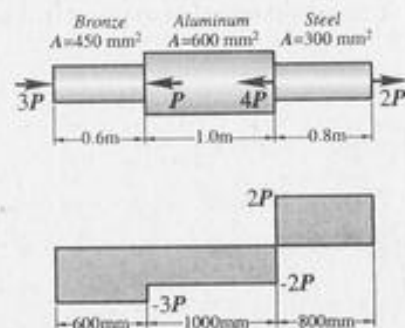

for steel:

$$P_s = A_s S_s$$

$$2P = (300)(140)$$

$$P = 21,000$$

Therefore, safe axial load

$$P = 18,000 \text{ N}$$

PROBLEM 211.

The rigid bars shown in the figure are separated by a roller at C and pinned at A and D. A steel rod at B helps support the load of 50 kN. Compute the vertical displacement of the roller at C.

Solution:

$$\sum M_A = 0$$

$$P(3) = 25(4.5)$$

$$P = 37.5 \text{ kN}$$

$$Y = \frac{PL}{AE}$$

$$Y_b = \frac{(37500)(3000)}{(300)(200 \times 10^3)}$$

$$Y_b = 1.875 \text{ mm}$$

By ratio and proportion:

$$\frac{y_c}{4.5} = \frac{Y_b}{3}$$

$$Y_c = \frac{(1.875)}{(3)} (4.5)$$

$$Y_c = 2.81 \text{ mm}$$

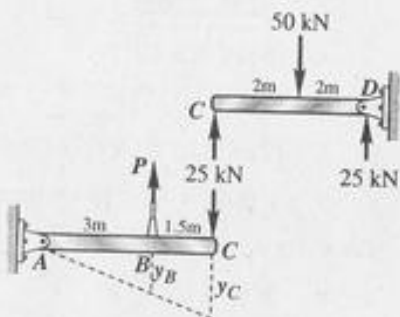
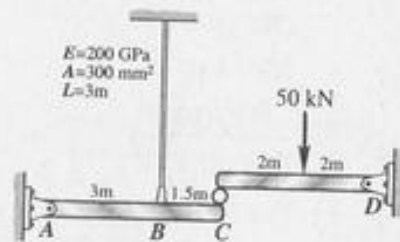

PROBLEM 212.

A uniform concrete slab of mass M is to be attached as shown in the figure, to two rods whose lower ends are initially at the same level. Determine the ratio of the areas of the rods so that the slab will remain level after it is attached to the rods.

Solution:

$$[\sum M_s = 0]$$

$$P_a(5) = w(3)$$

$$P_a = \frac{3}{5} w$$

$$P_s + P_a = w$$

$$P_s = w - \frac{3}{5} w$$

$$P_s = \frac{2}{5} w$$

$$Y = \frac{PL}{AE}$$

$$Y_s = Y_a$$

$$\frac{(\frac{2}{5} w)(3)}{(A_s)(200)} = \frac{(\frac{3}{5} w)(6)}{(A_a)(70)}$$

$$\frac{A_a}{A_s} = 8.57$$

PROBLEM 213.

The rigid bar AB, attached to two vertical rods as shown in the figure, is horizontal before the load is applied. If the load $P = 50 \text{ kN}$, determine its vertical movement.

Solution:

$$\sum M_A = 0$$

$$P_a(5) = 50(2)$$

$$P_a = 20 \text{ kN}$$

$$P_s + P_a = 50$$

$$P_s = 50 - 20$$

$$P_s = 30 \text{ kN}$$

$$y = \frac{PL}{AE}$$

$$y_s = \frac{(30,000)(3000)}{(300)(200 \times 10^3)}$$

$$y_s = 1.5 \text{ mm}$$

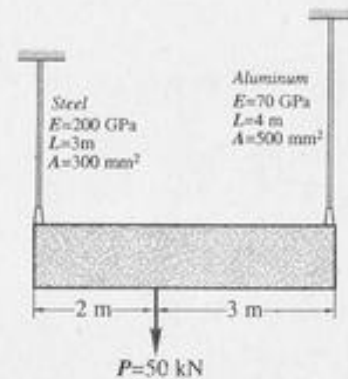
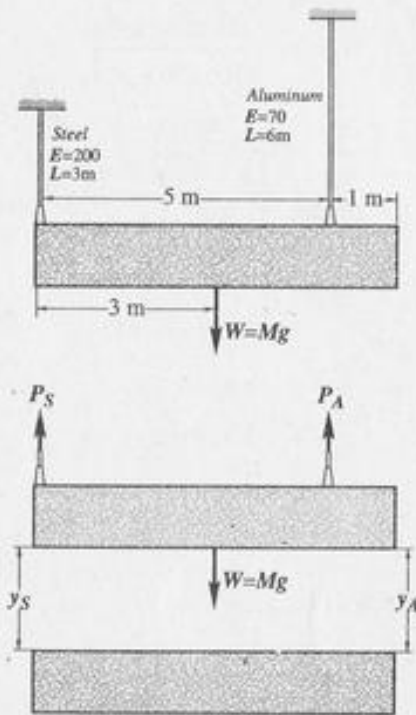

$$y_a = \frac{(20,000)(4000)}{(500)(70 \times 10^3)}$$

$$y_a = 2.286 \text{ mm}$$

$$y_a - y_s = 0.786 \text{ mm}$$

$$\frac{0.786}{5} = \frac{y_p - y_s}{2}$$

$$y_p - y_s = \frac{2}{5} (0.786)$$

$$y_p = 0.314 + 1.5$$

$$y_p = 1.814 \text{ mm}$$

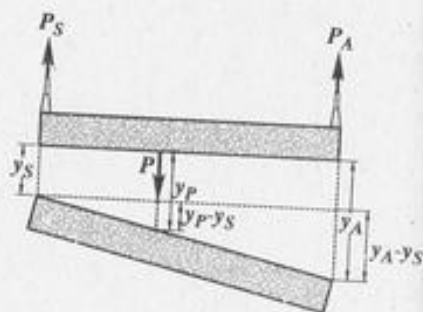

PROBLEM 214.

The rigid bars AB and CD shown in the figure are supported by pins at A and C and the two rods. Determine the maximum force P which can be applied as shown if its vertical movement is limited to 5 mm. Neglect the weights of all members.

Solution:

$$\sum M_c = 0$$

$$F_s(6) = P(3)$$

$$P_s = \frac{P}{2}$$

$$\sum M_A = 0$$

$$P_a(3) = P_s(6)$$

$$P_a = \left(\frac{P}{2}\right)\left(\frac{1}{2}\right)$$

$$P_a = P$$

$$y = \frac{PL}{AE}$$

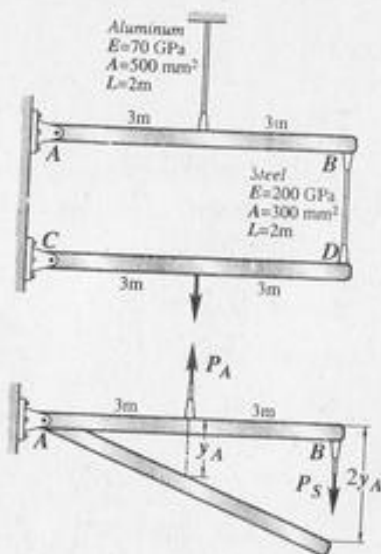

$$y_a = \frac{P(2000)}{(500)(70 \times 10^3)}$$

$$y_a = (5.714 \times 10^{-5}) P \text{ mm}$$

$$y_s = \frac{\left(\frac{P}{2}\right)(2000)}{(300)(200 \times 10^3)}$$

$$y_s = (1.667 \times 10^{-5}) P \text{ mm}$$

$$y_p = \frac{1}{2}(2y_a + y_s)$$

$$5 = \frac{1}{2}[2(5.714 \times 10^{-5})P + (1.667 \times 10^{-5})P]$$

$$5 = 6.5475 \times 10^{-5} P$$

$$P = 76,365 \text{ N}$$

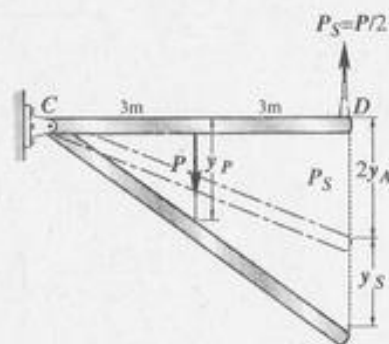

PROBLEM 215.

A round bar of length L tapers uniformly from a diameter D at one end to a smaller diameter d at the other. Determine the elongation caused by an axial tensile load P .

Solution:

$$\delta = \frac{PL}{AE}$$

$$d\delta = \frac{P dx}{\frac{\pi}{4}(d+y)^2 E}$$

$$d\delta = \frac{4P}{\pi E} \frac{dx}{(d+y)^2}$$

$$\frac{\delta}{x} = \frac{D-d}{L}$$

$$y = \frac{D-d}{L} x$$

$$d\delta = \frac{4P}{\pi E} \frac{dx}{\left[d + \frac{D-d}{L} x\right]^2}$$

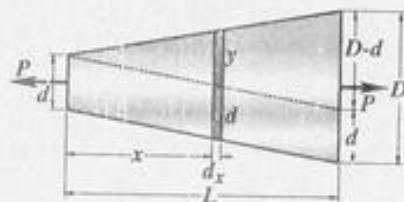

$$d\delta = \frac{4PL^2}{\pi E} \frac{dx}{[dL + (D-d)x]^2}$$

$$\delta = \frac{4PL^2}{\pi E} \int_0^L [dL + (D-d)x]^{-2} dx$$

$$\delta = -\frac{4PL^2}{\pi E(D-d)} [(dL + (D-d)x)^{-1}]_0^L$$

$$\delta = \frac{4PL^2}{\pi E(D-d)} \left[\frac{1}{(dL + (D-d)x)} \right]_0^L$$

$$\delta = -\frac{4PL^2}{\pi E(D-d)} \left[\frac{1}{dL + (D-d)L} - \frac{1}{dL} \right]$$

$$\delta = -\frac{4PL^2}{\pi E(D-d)} \left[\frac{1}{DL} - \frac{1}{dL} \right]$$

$$\delta = \frac{4PL}{\pi E(D-d)} \left[\frac{d-D}{Dd} \right]$$

$$\delta = \frac{4PL}{\pi E Dd}$$

PROBLEM 216.

A uniform slender rod of length L and cross-sectional area A is rotating in a horizontal plane about a vertical axis through one end. If the unit mass of the rod is P , and it is rotating at a constant angular velocity of w rad/sec, show that the total elongation of the rod is $\frac{pw^2L^3}{3E}$.

Solution:

$$P = m a_n$$

$$P = (p Ax) (r w^2)$$

$$P = (p Ax) \left(L - \frac{x}{2} \right) w^2$$

$$P = \frac{p A w^2}{2} [2Lx - x^2]$$

$$y = \frac{PL}{AE}$$

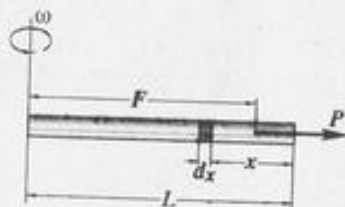

$$dy = \frac{p A w^2 [2Lx - x^2] dx}{2 A E}$$

$$y = \frac{p w^2}{2 E} \int_0^L [2Lx - x^2] dx$$

$$y = \frac{p w^2}{2 E} \left[Lx^2 - \frac{x^3}{3} \right]_0^L$$

$$y = \frac{p w^2 L^3}{3 E}$$

PROBLEM 217.

As shown in the figure, two aluminum rods AB and BC, hinged to rigid supports, are pinned together at B to carry a vertical load $P = 20$ kN. If each rod has a cross-sectional area of 400 mm^2 and $E = 70 \times 10^3 \text{ MN/m}^2$, compute the deformation of each rod and the horizontal and vertical displacement of point B. Assume $\alpha = 30^\circ$ and $\theta = 30^\circ$.

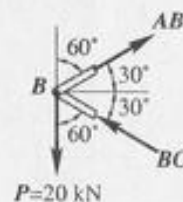
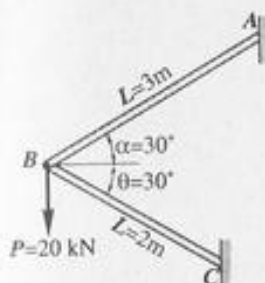

Solution:

$$y = \frac{PL}{AE}$$

$$y_{AB} = \frac{(20,000)(3000)}{(400)(70 \times 10^3)}$$

$$y_{AB} = 2.143 \text{ mm (elongation)}$$

$$y_{BC} = \frac{(20,000)(2000)}{(400)(70 \times 10^3)}$$

$$y_{BC} = 1.429 \text{ mm (contraction)}$$

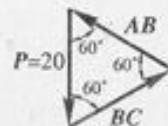

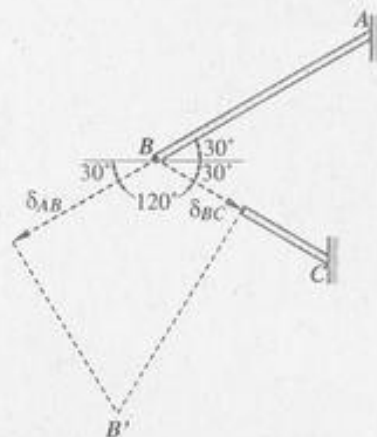

$$\cos \phi = \frac{2.143}{S_B}$$

$$S_B = 2.143 / \cos \phi$$

$$\cos(120 - \phi) = \frac{1.429}{S_B}$$

$$S_B = \frac{1.429}{\cos(120 - \phi)}$$

$$\frac{2.143}{\cos \phi} = \frac{1.429}{\cos(120 - \phi)}$$

$$1.5 \cos(120 - \phi) = \cos \phi$$

$$1.5 [\cos 120 \cos \phi + \sin 120 \sin \phi] = \cos \phi$$

$$1.5 [-0.5 \cos \phi + 0.866 \sin \phi] = \cos \phi$$

$$-0.75 \cos \phi + 1.299 \sin \phi = \cos \phi$$

$$1.299 \sin \phi = 1.75 \cos \phi$$

$$\tan \phi = \frac{1.75}{1.299}$$

$$\phi = 53.41^\circ$$

$$S_B = \frac{2.143}{\cos 53.41}$$

$$S_B = 3.595 \text{ mm}$$

$$\beta = 60 - \phi = 60 - 53.41$$

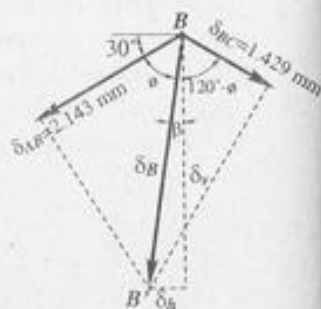

$$\beta = 6.587^\circ$$

$$S_h = S_B \sin \beta$$

$$S_h = 3.595 \sin 6.587^\circ = 0.412 \text{ mm (leftward)}$$

$$S_v = S_B \cos \beta$$

$$S_v = 3.595 \cos 6.587^\circ = 3.571 \text{ mm (downward)}$$

PROBLEM 218.

Solve Problem 217 if rod AB is of steel, with $E = 200 \times 10^3 \text{ MN/m}^2$. Assume $\alpha = 45^\circ$ and $\phi = 30^\circ$; all other data remain unchanged.

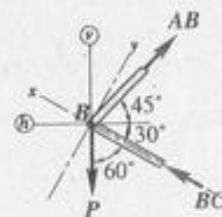

Solution:

$$[\sum y = 0]$$

$$AB \sin 75^\circ = 20 \sin 60^\circ$$

$$AB = 17.932 \text{ kN}$$

$$[\sum H = 0]$$

$$BC \cos 30^\circ = 17.932 \cos 45^\circ$$

$$BC = 14.641 \text{ kN}$$

$$S = \frac{PL}{AE}$$

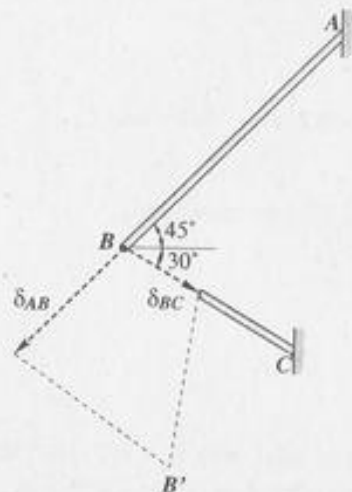

$$SAB = \frac{(17,932)(3000)}{(400)(2000 \times 10^3)}$$

$$SAB = 0.672 \text{ mm (elongation)}$$

$$SBC = \frac{(14,641)(2000)}{(400)(70 \times 10^3)}$$

$$SBC = 1.046 \text{ mm (contraction)}$$

$$\cos \phi = \frac{0.672}{SB}$$

$$\cos(105 - \phi) = \frac{1.046}{SB}$$

$$\frac{\cos \phi}{\cos(105 - \phi)} = \frac{0.672}{1.046}$$

$$1.557 \cos \phi = \cos(105 - \phi)$$

$$1.557 \cos \phi = \cos 105 \cos \phi + \sin 105 \sin \phi$$

$$1.557 \cos \phi = -0.259 \cos \phi + 0.966 \sin \phi$$

$$1.816 \cos \phi = 0.966 \sin \phi$$

$$\tan \phi = \frac{1.816}{0.966}$$

$$\phi = 62^\circ$$

$$\beta + 45 = \phi$$

$$\beta = 62 - 45$$

$$\beta = 17^\circ$$

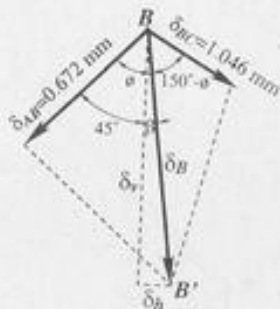

$$SB = \frac{0.672}{\cos \phi}$$

$$SB = \frac{0.672}{\cos 62^\circ}$$

$$SB = 1.431 \text{ mm}$$

$$S_v = SB \cos \beta$$

$$S_v = 1.431 \cos 17^\circ$$

$$S_v = 1.369 \text{ mm (downward)}$$

$$S_h = SB \sin \beta$$

$$S_h = 1.431 \sin 17^\circ$$

$$S_h = 0.418 \text{ mm (rightward)}$$

PROBLEM 219.

A round bar of length L , tapering uniformly from a diameter D at one end to a smaller diameter d at the other, is suspended vertically from the large end. If P is the unit mass, find the elongation caused by its own weight. Use this result to determine the elongation of a cone suspended from its base.

Solution:

$$S = \frac{PL}{AE}$$

$$dS = \frac{w dy}{AE}$$

By ratio and proportion

$$\frac{x}{y} = \frac{D - d}{L}$$

$$x = (D - d) \frac{y}{L}$$

$$d + x = d + \frac{(D - d)y}{L}$$

$$d + x = \frac{dL + (D - d)y}{L}$$

$$W = pgV$$

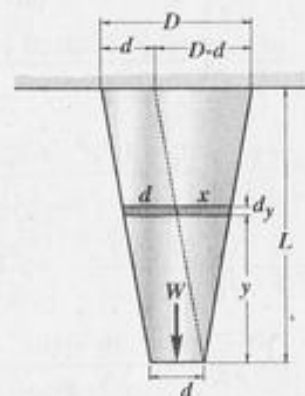

For a frustum of a cone,

$$V = \frac{\pi h}{3} (R^2 + r^2 + Rr)$$

$$V = \frac{\pi y}{3} \left[\left(\frac{d+x}{2}\right)^2 + \left(\frac{d}{2}\right)^2 + \left(\frac{d+x}{2}\right)\left(\frac{d}{2}\right) \right]$$

$$V = \frac{\pi y}{(3)(4)} [(D+x)^2 + d(d+x) + d^2]$$

$$W = pg \frac{\pi y}{12} [(d+x)^2 + d(d+x) + d^2]$$

$$A = \frac{\pi}{4} (d+x)^2$$

$$\frac{W}{A} = \frac{pgy}{3} \left[\frac{(d+x)^2 + d(d+x) + d^2}{(d+x)^2} \right]$$

$$\text{But } d+x = \frac{dL + (D-d)y}{L}$$

$$\frac{W}{A} = \frac{pgy}{3} \left\{ \frac{[dL + (D-d)y]^2 + d[dL + (D-d)y] + d^2}{\frac{[dL + (D-d)y]^2}{L}} \right\}$$

$$\frac{W}{A} = \frac{pgy}{3} \left\{ \frac{[dL + (D-d)y]^2 + dL[dL + (D-d)y] + d^2L^2}{(dL + (D-d)y)^2} \right\}$$

$$\frac{W}{A} = \frac{pgy}{3} \left\{ \frac{(dL)^2 + 2dL(D-d)y + (D-d)^2y^2 + (dL)^2 + dL(D-d)y + (dL)^2}{(dL + (D-d)y)^2} \right\}$$

$$\frac{W}{A} = \frac{pgy}{3} \left\{ \frac{(D-d)^2y^2 + 3dL(D-d)y + 3(dL)^2}{[dL + (D-d)y]^2} \right\}$$

$$\frac{W}{A} = \frac{pg}{3(D-d)} \left\{ \frac{(D-d)^3y^3 + 3dL(D-d)^2y^2 + 3(dL)^2(D-d)y}{[(dL + (D-d)y]^2} \right\}$$

$$\frac{W}{A} = \frac{pg}{3(D-d)} \frac{[(D-d)y + dL]^3 - (dL)^3}{[(D-d)y + dL]^2}$$

$$\frac{W}{A} = \frac{pg}{3(D-d)} \left\{ [(D-d)y + dL] - \frac{(dL)^3}{[(D-d)y + dL]^2} \right\}$$

Substitute $\frac{W}{A}$

$$dU = \frac{pg}{3(D-d)} \left\{ [(D-d)y + dL] - \frac{(dL)^3}{[(D-d)y + dL]^2} \right\} \frac{dy}{E}$$

$$U = \frac{pg}{3(D-d)^2 E} \int_0^L [(D-d)y + dL] - \frac{(dL)^3}{[(D-d)y + dL]^2} (D-d) dy$$

$$U = \frac{pg}{3(D-d)^2 E} \left\{ \frac{[(D-d)y + dL]^2}{2} + \frac{(dL)^3}{(D-d)y + dL} \right\}$$

$$U = \frac{pg}{3(D-d)^2 E} \left\{ \frac{[(D-d)L + dL]^2}{2} + \frac{(dL)^3}{(D-d)L + dL} - \frac{(dL)^2}{2} + \frac{(dL)^3}{dL} \right\}$$

$$U = \frac{pg}{3(D-d)^2 E} \left\{ \frac{(DL)^2}{2} + \frac{(dL)^3}{DL} - \frac{(dL)^2}{2} + (dL)^2 \right\}$$

$$U = \frac{pg}{3(D-d)^2 E} \left[\frac{D^2L^2}{2} + \frac{d^3L^2}{D} - \frac{3(dL)^2}{2} \right]$$

$$U = \frac{pg}{3(D-d)^2 E} \left[\frac{D^3L^2 + 2d^3L^2 - 3Dd^2L^2}{2D} \right]$$

$$U = \frac{pgL^2}{6E} \left[\frac{D^3 + 2d^3 - 3Dd^2}{D(D-d)^2} \right]$$

$$U = \frac{pgL^2}{6E} \left[\frac{(D-d)(D^2 + Dd - 2d^2)}{D(D-d)^2} \right]$$

$$U = \frac{pgL^2}{6E} \left[\frac{D^2 + Dd - 2d^2}{D(D-d)} \right]$$

$$U = \frac{pgL^2}{6E} \left[\frac{D(D+d) - 2d^2}{D(D-d)} \right]$$

$$U = \frac{pgL^2}{6E} \left[\frac{D(D+d)}{D(D-d)} \right] - \frac{pgL^2}{6E} \left[\frac{2d^2}{D(D-d)} \right]$$

$$U = \frac{pgL^2(D+d)}{6E(D-d)} - \frac{pgL^2d^2}{3ED(D-d)}$$

For a cone,

$$d = 0$$

$$U = \frac{pgL^2(D+0)}{6E(D-0)} - \frac{pgL^2(0)^2}{3ED(D-0)}$$

$$U = \frac{pgL^2}{6E}$$

POISSON'S RATIO: BIAXIAL AND TRIAXIAL DEFORMATIONS

PROBLEM 222.

A solid cylinder of diameter d carries an axial load P . Show that its change in diameter is $4 P\nu/\pi E d$.

Solution:

(Assume a tensile load)

$$S = \frac{P}{A}$$

$$S_x = \frac{P}{\frac{\pi d^2}{4}}$$

$$S_x = \frac{4P}{\pi d^2}$$

$$\nu = -\frac{E_y}{E_x}$$

$$E_y = -\nu E_x$$

$$E_y = -\nu \frac{S_x}{E}$$

$$E_y = -\frac{\nu(4P)}{\pi d^2 E}$$

$$S_y = E_y d$$

$$S_y = -\frac{4P\nu}{\pi d^2 E} (d)$$

$$S_y = -\frac{4P\nu}{\pi d E}$$

(lateral contraction for a tensile load)

$$S = -\frac{4PL^2}{\pi E(D-d)} \left[\frac{1}{dL + (D-d)L} - \frac{1}{dL} \right]$$

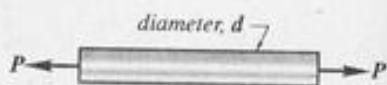

$$S = \frac{4PL^2}{\pi E(D-d)} \left[\frac{1}{DL} - \frac{1}{dL} \right]$$

$$S = \frac{4PL}{\pi E(D-d)} \frac{d-D}{Dd}$$

$$S = \frac{4PL}{\pi E Dd}$$

PROBLEM 223.

A rectangular aluminum block is 100 mm long in the X direction, 75 mm wide in the Y direction and 50 mm thick in the Z direction. It is subjected to a triaxial loading consisting of a uniformly distributed tensile force of 200 kN in the X direction and uniformly distributed compressive forces of 160 kN in the Y direction and 220 kN in the Z direction. If $\nu = 1/3$ and $E = 70$ GPa, determine a single distributed loading in the X direction that would produce the same Z deformation as the original loading.

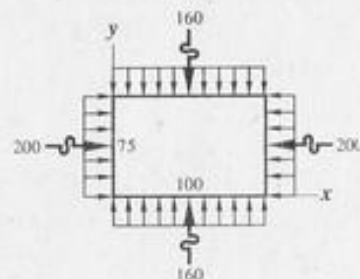
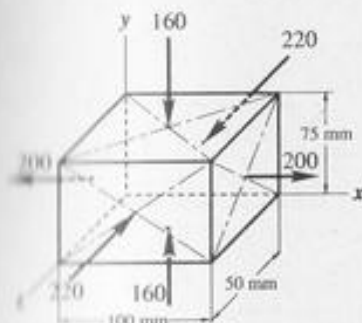

Solution:

For triaxial tensile stresses,

$$Ez = \frac{1}{E} [S_z - \nu (S_x + S_y)]$$

$$S_x = \frac{200(1000)}{(50)(75)}$$

$$S_x = 53.33 \text{ MPa } (+)$$

$$S_y = \frac{160(1000)}{(100)(50)}$$

$$S_y = 32 \text{ MPa } (-)$$

$$S_z = \frac{220(1000)}{(100)(75)}$$

$$S_z = 29.33 \text{ MPa } (-)$$

$$Ez = \frac{1}{70 \times 10^3} [(-29.33) - \frac{1}{3} (53.33 - 32)]$$

$$Ez = -5.206 \times 10^{-4}$$

Therefore the required load R_x is tensile.

$$S_x = \frac{R_x}{(50)(75)}$$

$$Ex = \frac{S_x}{E}$$

$$Ex = \frac{R_x}{(50)(75)(70 \times 10^3)}$$

$$Ex = \frac{R_x}{(50)(75)(70 \times 10^3)}$$

$$Ez = -\nu Ex$$

$$Ez = -\frac{1}{3} \frac{R_x}{(50)(75)(70 \times 10^3)}$$

$$-5.206 \times 10^{-4} = -\frac{R_x}{3(50)(75)(70 \times 10^3)}$$

$$R_x = 409,972 \text{ N}$$

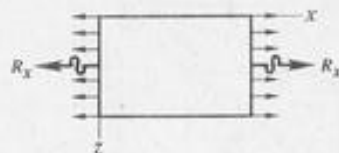
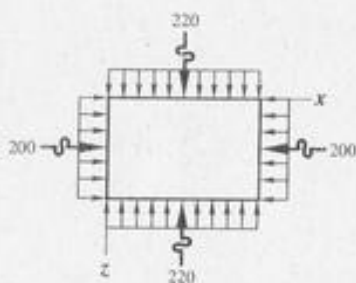

STATICALLY INDETERMINATE MEMBERS

PROBLEM 232.

A steel bar 50 mm in diameter and 2 m long is surrounded by a shell of cast iron 5 mm thick. Compute the load that will compress the combined bar a total of 1 mm in the length of 2 m. For steel, $E = 200 \times 10^9 \text{ N/m}^2$, and for cast iron, $E = 100 \times 10^9 \text{ N/m}^2$.

Solution:

$$S = \frac{PL}{AE}$$

$$A_s = \frac{\pi}{4} (50)^2 = 625 \pi \text{ mm}^2$$

$$A_{ci} = \frac{\pi}{4} (60)^2 - 625 \pi$$

$$A_{ci} = 275 \pi \text{ mm}^2$$

$$S_s = S_{ci} = 1 \text{ mm}$$

$$S_s = S_{ci} = 1 \text{ mm}$$

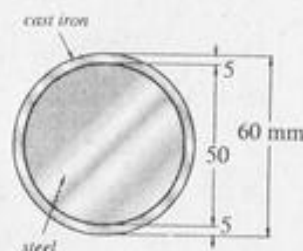

$$l = \frac{P_s (2000)}{(625 \pi) (200 \times 10^3)}$$

$$P_s = 196,350 \text{ N}$$

$$l = \frac{P_{ci} (2000)}{(275 \pi) (100 \times 10^3)}$$

$$P_{ci} = 43,197 \text{ N}$$

$$P = P_s + P_{ci}$$

$$P = 196,350 + 43,197$$

$$P = 239,547 \text{ N}$$

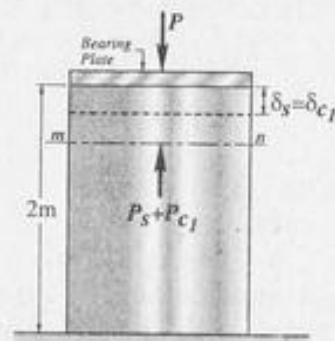

PROBLEM 233.

A reinforced concrete column 250 mm in diameter is designed to carry an axial compressive load of 400 kN. Using allowable stresses of $S_c = 6$ MPa and $S_s = 120$ MPa, determine the required area of reinforcing steel. Assume that $E_c = 14$ GPa and $E_s = 200$ GPa.

Solution:

$$S_s = S_c$$

$$\frac{S_s L}{E_s} = \frac{S_c L}{E_c}$$

$$\frac{S_s}{200} = \frac{S_c}{14}$$

$$S_s = 14.29 S_c$$

$$\text{when } S_c = 6 \text{ MPa}$$

$$S_s = (14.29)(6)$$

$$S_s = 85.71 \text{ MPa} < 120 \text{ MPa}$$

$$P_s + P_c = 400,000$$

$$S_s A_s + S_c A_c = 400,000$$

$$A_c = \frac{\pi}{4} (250)^2 - A_s$$

$$A_c = 15625 \pi - A_s$$

$$85.71 A_s + 6(15625 \pi - A_s) = 400,000$$

$$79.71 A_s = 400,000 - 6(15625 \pi)$$

$$A_s = 1323 \text{ mm}^2$$

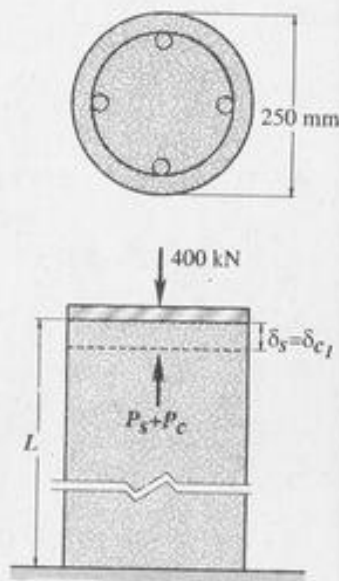

PROBLEM 234.

A timber block 250 mm square is supported on each side by a steel plate 250 mm wide and t mm thick. Determine the thickness t so that the assembly will support an axial load of 1200 kN without exceeding a maximum timber stress of 8 MN/m^2 or a maximum steel stress of 140 MN/m^2 . For timber, $E = 10 \times 10^3 \text{ MN/m}^2$; for steel, $E = 200 \times 10^3 \text{ MN/m}^2$.

Solution:

$$S_s = S_w$$

$$\frac{S_s L}{E_s} = \frac{S_w L}{E_w}$$

$$\frac{S_s}{200} = \frac{S_w}{10}$$

$$S_s = 20 S_w$$

$$\text{when } S_w = 8 \text{ MPa,}$$

$$S_s = 20(8)$$

$$S_s = 160 \text{ MPa} > 140 \text{ MPa}$$

(steel fails)

$$\text{Use } S_s = 140 \text{ MPa}$$

$$140 = 20 S_w$$

$$S_w = 7 \text{ MPa} < 8 \text{ MPa (safe)}$$

$$P_s + P_w = 1200 (1000)$$

$$A_s S_s + A_w S_w = 1,200,000$$

$$4(250 t)(140) + (250)(250)(7) = 1,200,000$$

$$t = 5.45 \text{ mm}$$

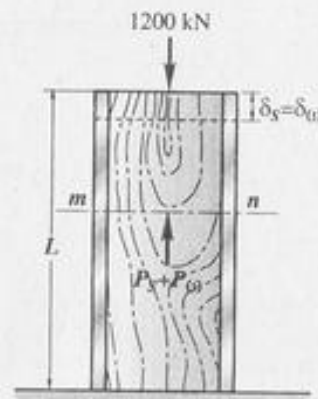

PROBLEM 235.

A rigid block of mass M is supported by three symmetrically spaced rods as shown in the figure. Each copper rod has an area of 900 mm^2 ; $E = 120$ GPa; and the allowable stress is 70 MPa. The steel rod has an area of 1200 mm^2 ; $E = 200$ GPa; and the allowable stress is 140 MPa. Determine the largest mass M which can be supported.

Solution:

$$S_s = S_c$$

$$\frac{S_s L_s}{E_s} = \frac{S_c L_c}{E_c}$$

$$\frac{S_s (240)}{200} = \frac{S_c (160)}{120}$$

$$S_s = 1.111 S_c$$

$$\text{when } S_c = 70 \text{ MPa}$$

$$S_s = 77.778 \text{ MPa} < 140 \text{ MPa}$$

$$W = P_s + 2 P_c$$

$$W = A_s S_s + 2 A_c S_c$$

$$Mg = (1200)(77.778) + 2(900)(70)$$

$$M(9.81) = 219,333 \text{ N}$$

$$M = 22,358 \text{ kg}$$

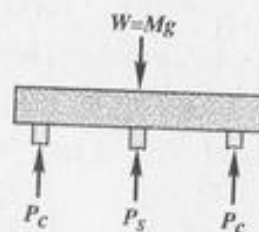
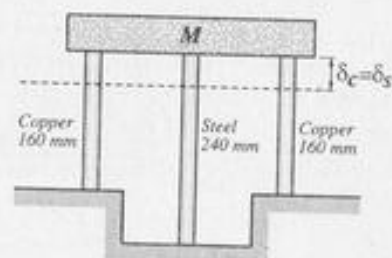

PROBLEM 236.

In Problem 235, how should the length of the steel rod be changed so that each material will be stressed to its allowable limit?

Solution:

$$S_s = S_c$$

$$\frac{S L}{E s} = \frac{S L}{E c}$$

$$\frac{140 L_s}{200} = \frac{70 (160)}{120}$$

$$L_s = 133.33 \text{ mm}$$

PROBLEM 237.

The lower ends of the three bars in the figure are at the same level before the rigid homogeneous 18 Mg block is attached. Each steel bar has an area of 600 mm^2 and $E = 200 \text{ GN/m}^2$. For the bronze bar, the area is 900 mm^2 and $E = 83 \text{ GN/m}^2$. Find the stresses developed in each bar.

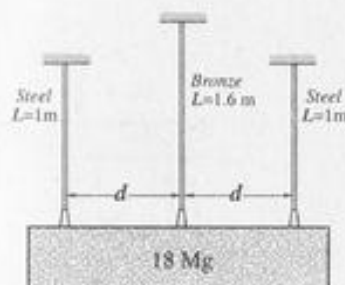

Solution:

$$S_s = S_b$$

$$\frac{S L}{E s} = \frac{S L}{E b}$$

$$\frac{S_s (1)}{200} = \frac{S_b (1.6)}{83}$$

$$S_s = 3.855 S_b$$

$$P_b + 2 P_s = W$$

$$A_b S_b + 2 A_s S_s = (18,000)(9)$$

$$900 S_b + 2(600)(3.855 S_b) = (18,000)(9.81)$$

$$S_b = 31.95 \text{ MPa}$$

$$S_s = 3.855 (31.95)$$

$$S_s = 123.2 \text{ MPa}$$

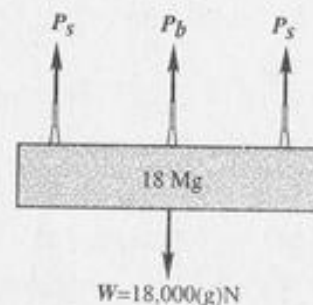

PROBLEM 238.

The rigid platform in the figure has negligible mass and rests on two aluminum bars, each 250 mm long. The center bar is steel and is 249.90 mm long. Find the stress in the steel bar after the center load $P = 400 \text{ kN}$ is applied. Each aluminum bar has an area of 1200 mm^2 and $E = 70 \text{ GPa}$. The steel bar has an area of 2400 mm^2 and $E = 200 \text{ GPa}$.

Solution:

$$s = \frac{SL}{E}$$

$$s_a = s_s + 0.10$$

$$\frac{SL}{E a} = \frac{SL}{E s} + 0.10$$

$$\frac{s_a (250)}{70 \times 10^3} = \frac{s_s (249.90)}{200 \times 10^3} + 0.10$$

$$s_a = 0.34986 s_s + 28$$

$$P_s + 2 P_a = 400 (1000)$$

$$A_s s_s + 2 A_a s_a = 400,000$$

$$2400 s_s + 2(1200)(0.34986 s_s + 28) = 400,000$$

$$s_s + 0.34986 s_s + 28 = 166.67$$

$$s_s = 102.73 \text{ MPa}$$

PROBLEM 239.

Three steel eye-bars, each 100 mm by 25 mm in section, are to be assembled by driving 20-mm-diameter drift pins through holes drilled in the ends of the bars. The center-line spacing between the holes is 10 m in the outer two bars but is 1.25 mm shorter in the middle bar. Find the shearing stress developed in the drift pins. Neglect local deformation at the holes and use $E_s = 200 \text{ GPa}$.

Solution:

$$s_m + s_o = 1.25 \text{ mm}$$

$$\frac{PL}{AE m} + \frac{PL}{AE o} = 1.25$$

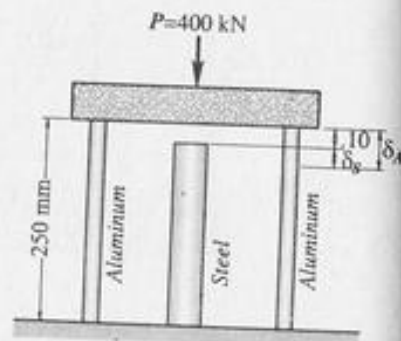

$$\frac{P_m (10,000)}{(2500)(200 \times 10^3)} + \frac{P_o (10,000)}{(25000)(200 \times 10^3)} = 1.25$$

$$P_m + P_o = 62,500$$

$$P_m = 2 P_o$$

$$2 P_o + P_o = 62,500$$

$$P_o = 20,833 \text{ N}$$

$$s_s = \frac{V}{A}$$

$$s_s = \frac{20,833}{\frac{\pi}{4} (20)^2}$$

$$s_s = 66.31 \text{ MPa}$$

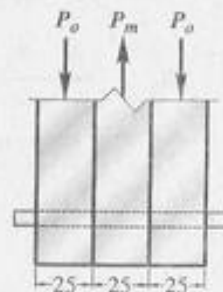
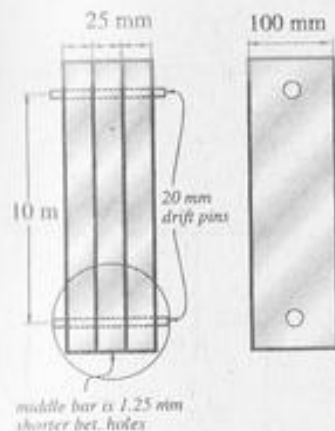
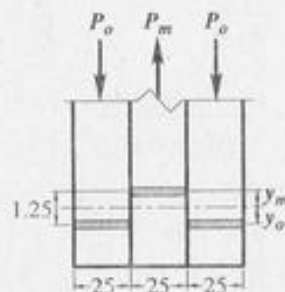

PROBLEM 240.

As shown in the figure, three steel wires, each 30 mm^2 in area, are used to lift a mass M . Their unstretched lengths are 19.994 m, 19.997 m, and 20.000 m. (a) If $M = 600 \text{ kg}$, what stress exists in the longest wire? (b) If $M = 200 \text{ kg}$, determine the stress in the shortest wire. Use $E = 200 \text{ GN/m}^2$.

Determine first the force P_2 and P_1 to bring all wires to a length of 20,000 mm.

$$S_1 = \frac{P_1 L_1}{A_1 E_1}$$

$$6 = \frac{P_1 (19,994)}{(30)(200 \times 10^3)}$$

$$P_1 = 1800.5 \text{ N}$$

$$S_2 = \frac{P_2 L_2}{A_2 E_2}$$

$$3 = \frac{P_2 (19,997)}{(30)(200 \times 10^3)}$$

$$P_2 = 900.1 \text{ N}$$

When the lengths of the wires are the same, each will carry equal loads.

$$P_3 = \frac{W - P_1 - P_2}{3}$$

$$P_3 = \frac{(600)(9.81) - 1800.5 - 900.1}{3}$$

$$P_3 = 1061.8 \text{ N}$$

$$S = \frac{P}{A}$$

$$S_3 = \frac{1061.8}{30} = 35.39 \text{ MPa}$$

(b) If $M = 200 \text{ kg}$

$$P_3 = \frac{200(9.81) - 1800.5 - 900.1}{3}$$

$$P_3 = -738.6 \text{ N} \quad (\text{remains slack})$$

$$P_2 = \frac{200(9.81) - 900.1}{2}$$

$$P_2 = 530.95 \text{ N}$$

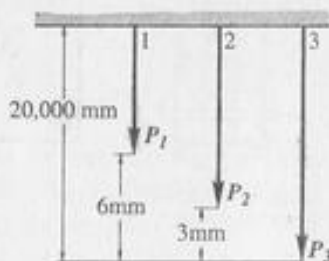
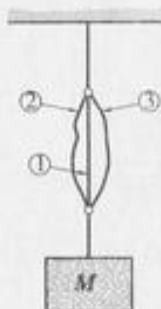

$$P_1 = 530.95 + 900.1$$

$$P_1 = 1431.05 \text{ N}$$

$$S_1 = \frac{1431.05}{30}$$

$$S_1 = 47.70 \text{ MPa}$$

PROBLEM 241.

The Assembly in the figure consists of a rigid bar AB (having negligible mass) pinned at O and attached to the aluminum rod and the steel rod. In the position shown, the bar AB is horizontal and there is a gap $d = 4 \text{ mm}$ between the lower end of the aluminum rod and its pin support at D. Find the stress in the steel rod when the lower end of the aluminum rod is pinned to the support at D.

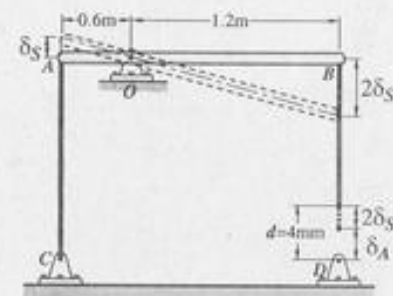
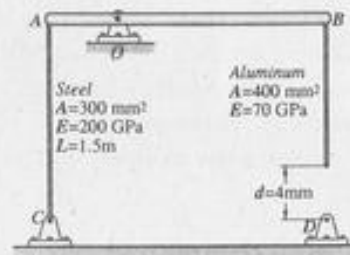

Solution:

$$2 S_s + S_a = 4$$

$$2 \left(\frac{SL}{E} \right)_s + \left(\frac{SL}{E} \right)_a = 4$$

$$L_a \approx 1.5 \text{ m}$$

$$\frac{2 S_s (1500)}{200 \times 10^3} + \frac{S_a (1500)}{70 \times 10^3} = 4$$

Simplifying,

$$7 S_s + 10 S_a = 1866.67$$

$$\sum M_o = 0$$

$$P_s (0.6) = P_a (1.2)$$

$$P_s = 2 P_a$$

$$S_s (300) = 2(S_a)(400)$$

$$S_a = 0.375 S_s$$

$$7 S_s + 10(0.375 S_s) = 1866.67$$

$$10.75 S_s = 1866.67$$

$$S_s = 173.64 \text{ MPa}$$

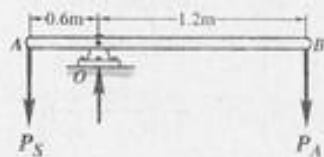

PROBLEM 242.

A homogeneous rod of constant cross-section is attached to unyielding supports. It carries an axial load P applied as shown in the figure. Prove that the reactions are given by $R_1 = Pb/L$ and $R_2 = Pa/L$.

Solution:

$$S_1 = S_2$$

$$\frac{R_1 (a)}{AE} = \frac{(P - R_1) b}{AE}$$

$$R_1 a = Pb - R_1 b$$

$$R_1 (a + b) = Pb$$

$$R_1 = \frac{Pb}{L}$$

$$R_2 = P - R_1$$

$$R_2 = P - \frac{Pb}{L}$$

$$R_2 = \frac{PL - Pb}{L}$$

$$R_2 = \frac{P(L - b)}{L}$$

$$R_2 = \frac{Pa}{L}$$

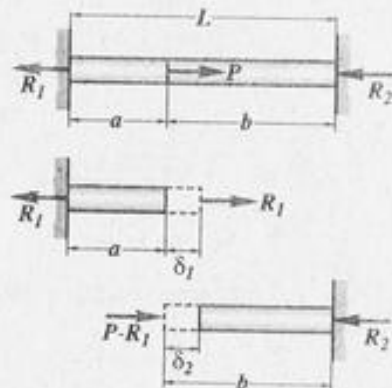

PROBLEM 243.

A homogeneous bar with a cross-sectional area of 500 mm^2 is attached to rigid supports. It carries the axial loads $P_1 = 25 \text{ kN}$ and $P_2 = 50 \text{ kN}$, applied as shown. Determine the stress in the segment BC. (Hint: Use the results of Problem 242, and compute the reactions caused by P_1 and P_2 acting separately. Then use the principle of superposition to compute the reactions when both loads are applied.)

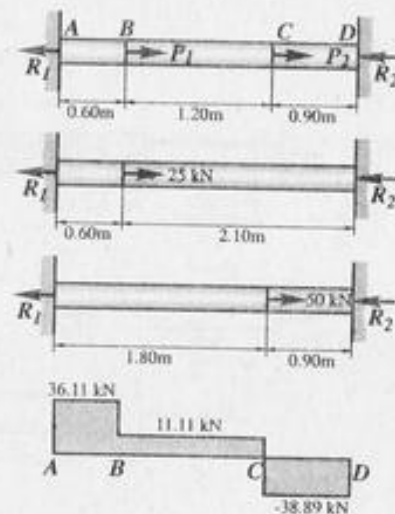

Solution:

$$R_1 = R_1' + R_1''$$

$$R_1 = \frac{P_1 b_1}{L_1} + \frac{P_2 b_2}{L_2}$$

$$R_1 = \frac{(25)(2.10)}{2.70} + \frac{(50)(0.90)}{2.70}$$

$$R_1 = 36.11 \text{ kN}$$

$$\text{Force acting on BC} = 36.11 - 25 = 11.11 \text{ kN}$$

$$S = \frac{P}{A}$$

$$S = \frac{11.11 (1000)}{500}$$

$$S = 22.22 \text{ MPa}$$

PROBLEM: 244.

The bar shown is firmly attached to unyielding supports. Find the stress caused in each material by applying an axial load $P = 200 \text{ kN}$.

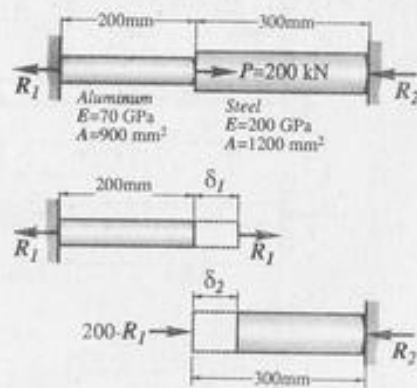

Solution:

$$S_1 = S_2$$

$$\frac{R_1 (200)}{(900)(70)} = \frac{(200 - R_1) (300)}{(1200)(200)}$$

$$2.54 R_1 = 200 - R_1$$

$$R_1 = 56.5 \text{ kN}$$

$$R_2 = 200 - R_1$$

$$R_2 = 200 - 56.5$$

$$R_2 = 143.5 \text{ kN}$$

$$S_a = \frac{56.5 (1000)}{900} = 62.8 \text{ MPa}$$

$$S_s = \frac{143.5 (1000)}{1200} = 119.6 \text{ MPa}$$

PROBLEM 245.

Refer to Problem 244. What maximum load P can be applied without exceeding an allowable stress of 70 MPa for aluminum or 120 MPa for steel? Can a larger load P be carried if the length of the aluminum rod be changed, the length of the steel portion being kept the same? If so, determine this length.

Solution:

Since $S_s = 119.6 \text{ MPa} \approx 120 \text{ MPa}$, therefore maximum load $P = 200 \text{ kN}$.

A larger load P can be carried if the aluminum and steel portions will reach the maximum allowable stresses simultaneously.

$$S_A = S_s$$

$$\frac{S_A L_A}{E A} = \frac{S_s L_s}{E s}$$

$$\frac{70 (L_A)}{70} = \frac{120(300)}{200}$$

$$L_A = 180 \text{ mm}$$

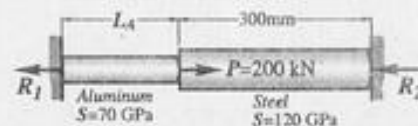

PROBLEM 246.

A rod is composed of three segments shown in the figure and carries the axial loads $P_1 = 120$ kN and $P_2 = 50$ kN. Determine the stress in each material if the walls are rigid.

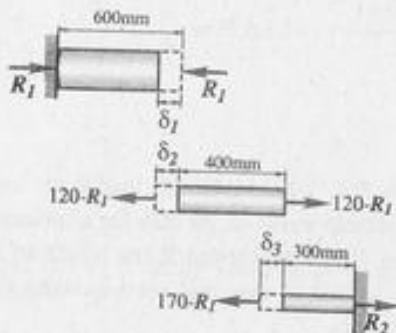
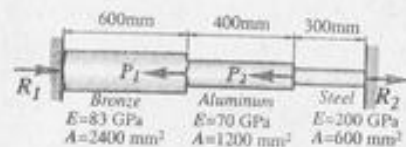

Solution:

$$S_1 = S_2 + S_3$$

$$\frac{R_1(600)}{(2400)(83)} = \frac{(120 - R_1)(400)}{(1200)(70)} + \frac{(170 - R_1)(300)}{(600)(200)}$$

$$R_1 = 97 \text{ kN}$$

$$R_2 = 170 - R_1$$

$$R_2 = 170 - 97$$

$$R_2 = 73 \text{ kN}$$

$$S = \frac{P}{A}$$

For Bronze:

$$S_B = \frac{97(1000)}{2400} = 40.42 \text{ MPa}$$

For aluminum:

$$P = 120 - R_1 = 120 - 97$$

$$P = 23 \text{ kN}$$

$$S_A = \frac{23(1000)}{1200} = 19.17 \text{ MPa}$$

For steel:

$$S_s = \frac{73(1000)}{600} = 121.67 \text{ MPa}$$

PROBLEM 247.

Solve Problem 246 if the left wall yields 0.60 mm.

Solution:

$$S_1 + 0.60 = S_2 + S_3$$

$$\frac{R_1(600)}{(2400)(83)} + 0.60 = \frac{(120 - R_1)(400)}{(1200)(70)} + \frac{(170 - R_1)(300)}{(600)(200)}$$

$$R_1 = 38.586 \text{ kN}$$

$$R_2 = 170 - R_1$$

$$R_2 = 170 - 38.586$$

$$R_2 = 131.414 \text{ kN}$$

$$S_B = \frac{38.586(1000)}{2400} = 16.08 \text{ MPa}$$

$$S_s = \frac{131.414(1000)}{600} = 219.02 \text{ MPa}$$

For aluminum:

$$P = 120 - R_1$$

$$P = 120 - 38.586$$

$$P = 81.414 \text{ kN}$$

$$S_a = \frac{81.414(1000)}{1200} = 67.85 \text{ MPa}$$

PROBLEM 248.

A steel tube 2.5 mm thick just fits over an aluminum tube 2.5 mm thick. If the contact diameter is 100 mm, determine the contact pressure and tangential stresses when the outward radial pressure on the aluminum tube is $p = 4 \text{ MN/m}^2$. Here, $E_s = 200 \times 10^9 \text{ N/m}^2$, and $E_a = 70 \times 10^9 \text{ N/m}^2$.

Solution:

$$2 P_s + 2 P_a = 4(95)(1)$$

$$P_s + P_a = 190$$

$$S_s = S_a$$

$$\frac{P_s L_s}{A_s E_s} = \frac{P_a L_a}{A_a E_a}$$

$$\frac{P_s}{200} = \frac{P_a}{70}$$

$$P_s = 2.857 P_a$$

$$2.857 P_a + P_a = 190$$

$$P_a = 49.26 \text{ N}$$

$$P_s = 2.857 (49.26)$$

$$P_s = 140.73 \text{ N}$$

$$S = \frac{P}{\bar{A}}$$

$$S_a = \frac{49.26}{(2.5)(1)} = 19.7 \text{ MPa}$$

$$S_s = \frac{140.73}{(2.5)(1)} = 56.3 \text{ MPa}$$

$$S_s = \frac{140.73}{(2.5)(1)} = 56.3 \text{ MPa}$$

Contact pressure

$$P_c (100)(1) + 2 P_a = 4 (95)(1)$$

$$P_c (100) = 380 - 2 (49.26)$$

$$P_c = 2.81 \text{ MPa}$$

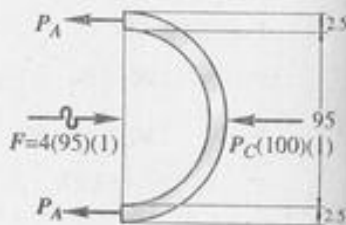
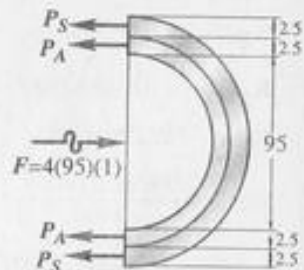
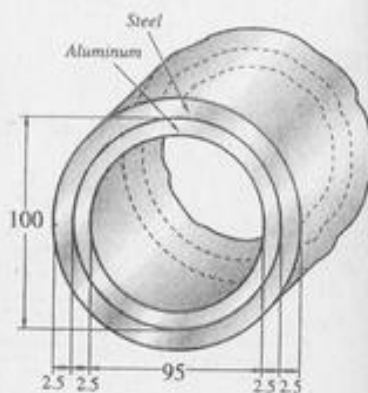
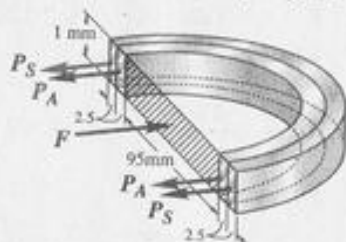

PROBLEM 250.

In the assembly of the bronze tube and steel bolt shown, the pitch of the bolt thread is 0.80 mm and the cross-sectional area of the bronze tube is 900 mm^2 and of the steel bolt is 450 mm^2 . The nut is turned until there is a compressive stress of 30 MN/m^2 in the bronze tube. Find the stress in the bronze tube if the nut is then given one additional turn. How many turns of the nut will reduce this stress to zero? $E_b = 83 \text{ GPa}$, $E_s = 200 \text{ GPa}$.

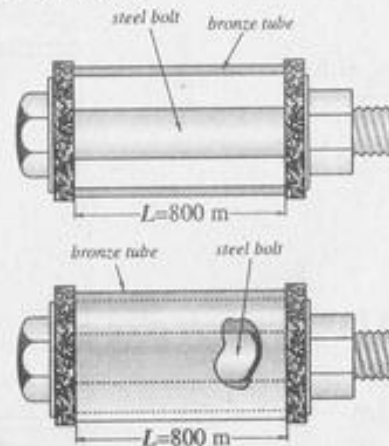

Solution:

For one additional turn of the nut

$$0.80 = S_s + S_b$$

$$0.80 = \frac{S_s (800)}{200 \times 10^3} + \frac{S_b (800)}{83 \times 10^3}$$

$$800 = 4 S_s + 9.64 S_b$$

$$P_b = P_s$$

$$A_b S_b = A_s S_s$$

$$900 S_b = 450 S_s$$

$$S_s = 2 S_b$$

$$800 = 4 (2 S_b) + 9.64 S_b$$

$$S_b = 45.35 \text{ MPa}$$

Total stress

$$S_b = 30 + 45.35 = 75.35 \text{ MPa}$$

To reduce S_b to zero, required number of turns

$$n = \frac{75.35}{45.35} = 1.66 \text{ turns}$$

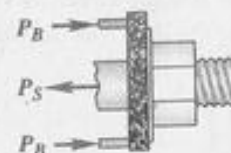

PROBLEM 251.

As shown in the figure, a rigid beam with negligible mass is pinned at O and supported by two rods, identical except for length. Determine the load in each rod if $P = 30$ kN.

Solution:

$$\frac{S_A}{2} = \frac{S_B}{3.5}$$

$$S_B = 1.75 S_A$$

$$\frac{P_B (2)}{AE} = \frac{1.75 P_A (1.5)}{AE}$$

$$P_B = 1.3125 P_A$$

$$\Sigma M_O = 0$$

$$P_A (2) + P_B (3.5) = 30(2)$$

$$2 P_A + 3.5 (1.3125 P_A) = 60$$

$$P_A = 9.10 \text{ kN}$$

$$P_B = 1.3125 (9.10)$$

$$P_B = 11.94 \text{ kN}$$

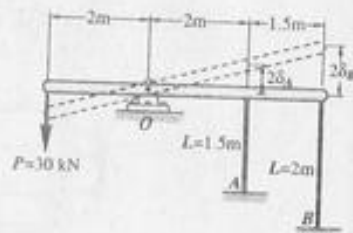

PROBLEM 252.

As shown in the figure, a rigid beam with negligible mass is pinned at one end and supported by two rods. The beam was initially horizontal before the load was applied. Find the vertical movement of P if $P = 120$ kN;

Solution:

$$\frac{S_A}{6} = \frac{S_B}{3}$$

$$S_A = 2 S_B$$

$$\frac{P_A (3)}{(900)(70)} = \frac{2 P_B (4)}{(600)(200)}$$

$$P_A = 1.4 P_B$$

$$\Sigma M_O = 0$$

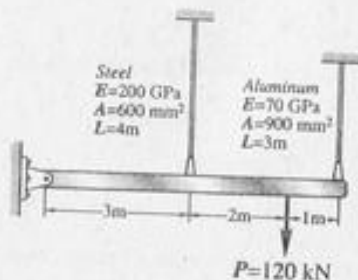

$$P_S (3) + P_A (6) = P (5)$$

$$3 P_S + 6(1.4 P_S) = 120 (5)$$

$$P_S = 52.63 \text{ N}$$

$$S_S = \frac{(52.63)(4000)}{(600)(200)}$$

$$S_S = 1.75 \text{ mm}$$

By ratio and proportion,

$$\frac{S_P}{5} = \frac{S_S}{3}$$

$$S_P = \frac{5(1.75)}{3} = 2.92 \text{ mm}$$

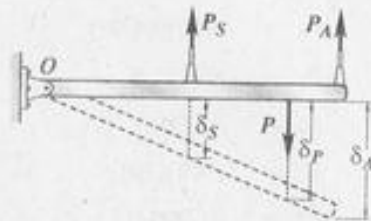

PROBLEM 253.

A rigid bar of negligible mass, pinned at one end, is supported by a steel rod and a bronze rod as shown. What maximum load P can be applied without exceeding a stress in the steel of 120 MN/m^2 or in the bronze of 70 MN/m^2 .

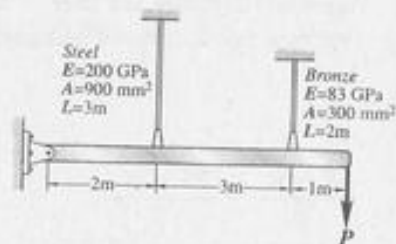

Solution:

$$\frac{S_S}{2} = \frac{S_B}{5}$$

$$S_S = 0.4 S_B$$

$$\frac{S_S (3)}{200} = \frac{0.4 S_B (2)}{83}$$

$$S_S = 0.643 S_B$$

$$\text{When } S_B = 70 \text{ MPa}$$

$$S_S = 0.643 (70) = 44.98 \text{ MPa} < 120 \text{ MPa}$$

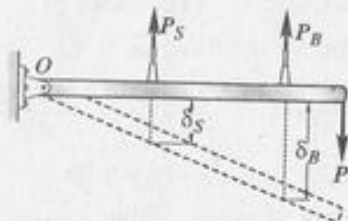

$$P_s = A_s S_s$$

$$P_s = (900)(44.98)$$

$$P_s = 40,481 \text{ N}$$

$$P_b = A_b S_b$$

$$P_b = (300)(70)$$

$$P_b = 21,000 \text{ N}$$

$$\Sigma M_o = 0$$

$$P(6) = P_s(2) + P_b(5)$$

$$6P = 40,481(2) + 21,000(5)$$

$$P = 30,994 \text{ N}$$

PROBLEM 254.

Shown in the figure is a section through a balcony. The total uniform load of 600 kN is supported by three rods of the same area and material. Compute the load in each rod. Assume the floor to be rigid but note that it does not necessarily remain horizontal.

Solution:

$$\frac{S_A - S_c}{6} = \frac{S_B - S_c}{2}$$

$$S_A - S_c = 3S_B - 3S_c$$

$$S_A = 3S_B - 2S_c$$

$$\frac{P_A(5)}{AE} = \frac{3P_B(6)}{AE} - \frac{2P_c(6)}{AE}$$

$$5P_A = 18P_B - 12P_c$$

$$5P_A = 18P_B - 12P_c$$

$$P_A = 3.6P_B - 2.4P_c$$

$$\Sigma M_A = 0$$

$$P_B(4) + P_c(6) = (600)(3)$$

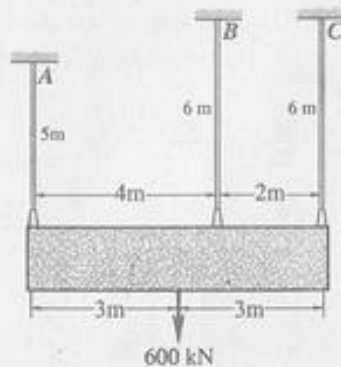

$$P_B = 450 - 1.5P_c$$

$$P_A + P_B + P_c = 600$$

$$(3.6P_B - 2.4P_c) + P_B + P_c = 600$$

$$4.6P_B - 1.4P_c = 600$$

$$4.6(450 - 1.5P_c) - 1.4P_c = 600$$

$$2070 - 6.9P_c - 1.4P_c = 600$$

$$P_c = 177.11 \text{ kN}$$

$$P_B = 450 - 1.5(177.11)$$

$$P_B = 184.34 \text{ kN}$$

$$P_A = 3.6(184.34) - 2.4(177.11)$$

$$P_A = 238.56 \text{ kN}$$

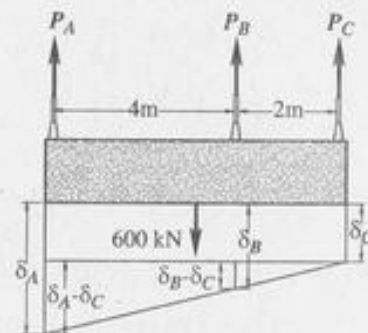

PROBLEM 255.

Three rods, each with an area of 300 mm^2 , jointly support the load of 20 kN, as shown. Assuming there was no slack or stress in the rods before the load was applied, find the stress in each rod. Here, $E_s = 200 \times 10^9 \text{ N/m}^2$ and $E_b = 83 \times 10^9 \text{ N/m}^2$.

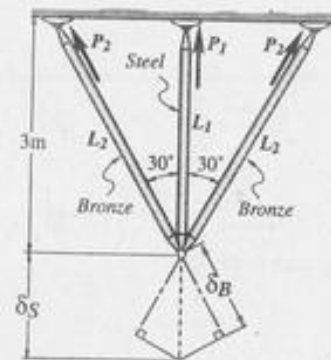
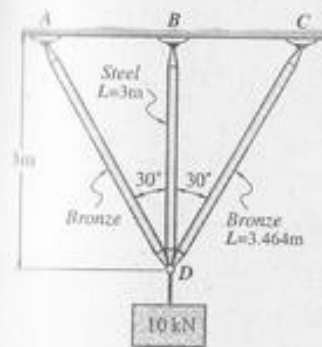

Solution:

$$\cos 30^\circ = \frac{3}{L_b}$$

$$L_b = 3.464 \text{ m}$$

$$S_b = S_s \cos 30^\circ$$

$$\frac{S_b (3.464)}{83} = \frac{S_s \cos 30^\circ (3)}{200}$$

$$S_b = 0.31126 S_s$$

$$P_s + 2 P_b \cos 30^\circ = 10 \text{ kN}$$

$$S_s A_s + 2 A_b S_b \cos 30^\circ = 10(1000)$$

$$S_s (300) + 2(300)(0.31126 S_s) \cos 30^\circ = 10,000$$

$$S_s = 21.66 \text{ MPa}$$

$$S_b = 0.31126 (21.66)$$

$$S_b = 6.74 \text{ MPa}$$

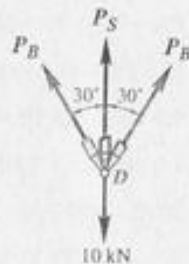

PROBLEM 256.

Three bars, AB, AC, and AD, are pinned together to support a load $P = 20 \text{ kN}$ as shown. Horizontal movement is prevented at joint A by the short horizontal strut AE. For the steel bar, $A = 200 \text{ mm}^2$ and $E = 200 \text{ GPa}$. For each aluminum bar, $A = 400 \text{ mm}^2$ and $E = 70 \text{ GPa}$. Determine the stress in each bar and the force in the strut AE.

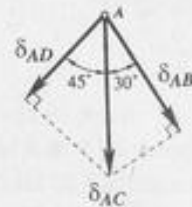
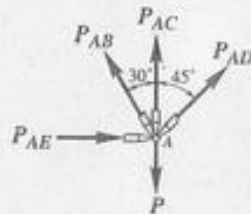
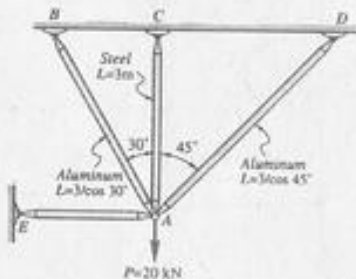

Solution:

$$S_{AB} = S_{AC} \cos 30^\circ$$

$$\frac{P_{AB} (3 / \cos 30^\circ)}{(400)(70)} = \frac{P_{AC} \cos 30^\circ (3)}{(200)(200)}$$

$$P_{AB} = 0.525 P_{AC}$$

$$S_{AD} = S_{AC} \cos 45^\circ$$

$$\frac{P_{AD} (3 / \cos 45^\circ)}{(400)(70)} = \frac{P_{AC} (3) \cos 45^\circ}{(200)(200)}$$

$$P_{AD} = 0.35 P_{AC}$$

$$P_{AC} + P_{AD} \cos 45^\circ + P_{AB} \cos 30^\circ = 20 S_{AC}$$

$$P_{AC} + (0.35 P_{AC}) \cos 45^\circ + (0.525 P_{AC}) \cos 30^\circ = 20$$

$$P_{AC} = 11.75 \text{ kN}$$

$$P_{AB} = (0.525)(11.75) = 6.169 \text{ kN}$$

$$P_{AD} = (0.35)(11.75) = 4.113 \text{ kN}$$

$$S = \frac{P}{\bar{A}}$$

$$S_{AC} = \frac{11.75(1000)}{200} = 58.75 \text{ MPa}$$

$$S_{AB} = \frac{6.169(1000)}{400} = 15.42 \text{ MPa}$$

$$S_{AD} = \frac{4.113(1000)}{400} = 10.28 \text{ MPa}$$

$$\Sigma H = 0$$

$$P_{AE} + P_{AD} \sin 45^\circ = P_{AB} \sin 30^\circ$$

$$P_{AE} + 4.113 \sin 45^\circ = 6.169 \sin 30^\circ$$

$$P_{AE} = 0.176 \text{ kN}$$

$$P_{AE} = 176 \text{ N}$$

PROBLEM 257.

Refer to the data in Problem 256, and determine the maximum value of P that will not exceed an aluminum stress of 40 MPa or a steel stress of 120 MPa.

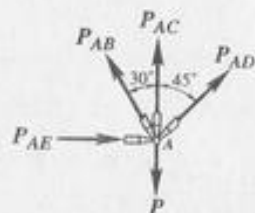

Solution:

$$S = \frac{SL}{E}$$

$$S_{AC} = \frac{S_{AB}}{\cos 30^\circ} = \frac{S_{AD}}{\cos 45^\circ}$$

$$\frac{S_{AC}(3)}{200} = \frac{S_{AB}(3/\cos 30^\circ)}{70 \cos 30^\circ} = \frac{S_{AD}(3/\cos 45^\circ)}{70 \cos 45^\circ}$$

$$S_{AC} = 3.81 S_{AB} = 5.71 S_{AD}$$

when $S_{AC} = 120 \text{ MPa}$

$$S_{AB} = \frac{120}{3.81} = 31.5 \text{ MPa} < 40 \text{ MPa}$$

$$S_{AD} = \frac{120}{5.71} = 21.02 \text{ MPa} < 40 \text{ MPa}$$

Therefore, use $S_{AC} = 120 \text{ MPa}$

$$S_{AB} = 31.5 \text{ MPa}$$

$$S_{AD} = 21.02 \text{ MPa}$$

$$P = P_{AB} \cos 30^\circ + P_{AC} + P_{AD} \cos 45^\circ$$

$$P = (31.5)(400) \cos 30^\circ + (120)(200) + (21.02)(400) \cos 45^\circ$$

$$P = 40,856 \text{ MPa}$$

THERMAL STRESSES

PROBLEM 261.

A steel rod with a cross-sectional area of 150 mm^2 is stretched between two fixed points. The tensile load at 20°C is 5000 N. What will be the stress at -20°C ? At what temperature will the stress be zero? Assume $\alpha = 11.7 \text{ } \mu\text{m/cm}^\circ\text{C}$ and $E = 200 \times 10^9 \text{ N/m}^2$.

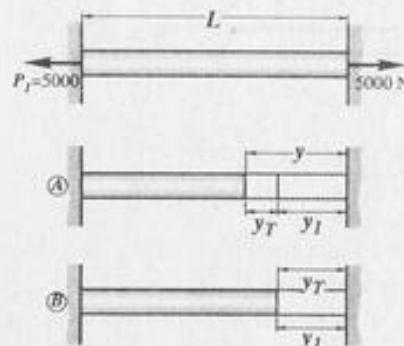

Solution:

$$(a) y = Y_T + Y_I$$

$$\frac{SL}{E} = \alpha L \Delta T + \frac{P_1 L}{AE}$$

$$\frac{S}{200 \times 10^3} = (11.7 \times 10^{-6})(40^\circ) + \frac{5000}{150(200 \times 10^3)}$$

$$S = 126.9 \text{ MPa.}$$

$$(b) Y_T = Y_I$$

$$\alpha L \Delta T = \frac{P_1 L}{AE}$$

$$(11.7 \times 10^{-6})(T - 20^\circ) = \frac{5000}{150(200 \times 10^3)}$$

$$T = 34.2^\circ\text{C}$$

PROBLEM 262.

A steel rod is stretched between two rigid walls and carries a tensile load of 5000 N, at 20°C. If the allowable stress is not to exceed 130 MN/m² at -20°C, what is the minimum diameter of the rod? Assume $\alpha = 11.7 \mu\text{m}/(\text{m } ^\circ\text{C})$ and $E = 200 \text{ GPa}$.

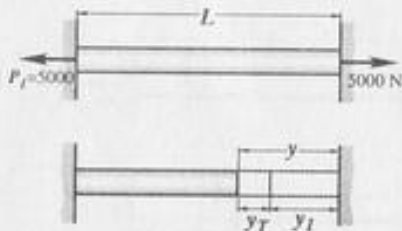

Solution:

$$y = Y_T + Y_I$$

$$\frac{SL}{E} = \alpha L \Delta T + \frac{P_I L}{AE}$$

$$\frac{130}{200 \times 10^3} = (11.7 \times 10^{-6})(40) + \frac{5000}{A(200 \times 10^3)}$$

$$A = 137.4 \text{ mm}^2$$

$$\frac{\pi}{4} d^2 = 137.4 \text{ mm}^2$$

$$d = 13.22 \text{ mm}$$

PROBLEM 263.

Steel railroad rails 10 m long are laid with a clearance of 3 mm at a temperature of 15°C. At what temperature will the rails just touch? What stress will be induced in the rails at that temperature if there were no initial clearance? Assume $\alpha = 11.7 \times 10^{-6} \text{ m}/(\text{m } ^\circ\text{C})$ and $E = 200 \text{ GPa}$.

Solution:

$$Y_T = \alpha L \Delta T$$

$$3 = (11.7 \times 10^{-6})(10,000)(T - 15)$$

$$T = 40.64^\circ\text{C}$$

$$Y = \frac{SL}{E}$$

$$3 = \frac{S(10,000)}{200 \times 10^3}$$

$$S = 60 \text{ MPa}$$

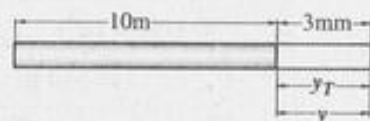

PROBLEM 264.

At a temperature of 90°C, a steel tire 10 mm thick and 75 mm wide that is to be shrunk onto a locomotive driving wheel 1.8 m in diameter just fits over the wheel, which is at a temperature of 20°C. Determine the contact pressure between the tire and the wheel after the assembly cools to 20°C. Neglect the deformation of the wheel caused by the pressure of the tire. Assume $\alpha = 11.7 \mu\text{m}/(\text{m } ^\circ\text{C})$ and $E = 200 \times 10^9 \text{ N/m}^2$.

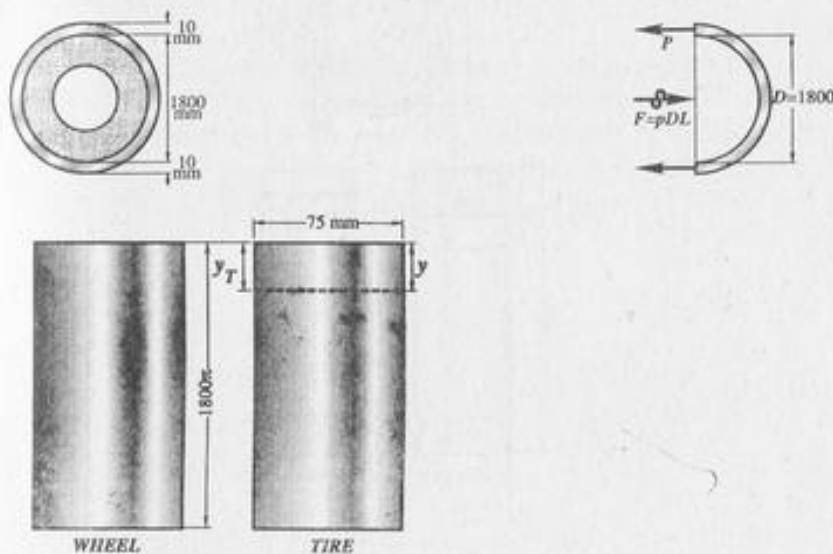

Solution:

$$Y = Y_T$$

$$\frac{PL}{AE} = \alpha L \Delta T$$

$$\frac{P}{750(200 \times 10^3)} = (11.7 \times 10^{-6})(90 - 20)$$

$$P = 122,850 \text{ N}$$

$$2P = F = pDL$$

$$2(122,850) = p(1800)(75)$$

$$p = 1.82 \text{ MPa}$$

PROBLEM 265.

At 130°C , a bronze hoop 20 mm thick whose inside diameter is 600 mm just fits snugly over a steel hoop 15 mm thick. Both hoops are 100 mm wide. Compute the contact pressure between the hoops when the temperature drops to 20°C . Neglect the possibility that the inner ring may buckle. For steel, $E = 200 \text{ GPa}$ and $\alpha = 11.7 \mu\text{m}/(\text{m}^\circ\text{C})$. For bronze, $E = 83 \text{ GPa}$ and $\alpha = 19 \mu\text{m}/(\text{m}^\circ\text{C})$.

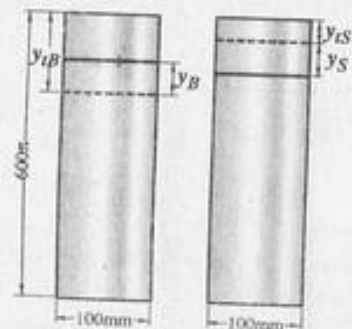
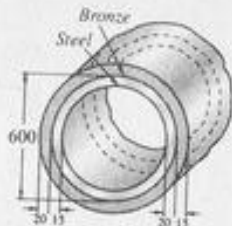

Solution:

$$Y_{tB} - Y_B = Y_{ts} + Y_s$$

$$(19 \times 10^{-6})(L)(130^\circ - 20^\circ) - \frac{P_B(L)}{(20)(100)(83 \times 10^3)}$$

$$(11.7 \times 10^{-6})(L)(130^\circ - 20^\circ) + \frac{P_s(L)}{(15)(100)(200 \times 10^3)}$$

$$0.00209 - 6.024 \times 10^{-9} P_B = 0.001287 + 3.333 \times 10^{-9} P_s$$

$$2P_B = 2P_s$$

$$P_B = P_s$$

$$9.357 \times 10^{-9} P_B = 0.000803$$

$$P_B = 85,815 \text{ N}$$

$$p(600)(100) = 2P_B$$

$$p(60,000) = 2(85,815)$$

$$p = 2.86 \text{ MPa}$$

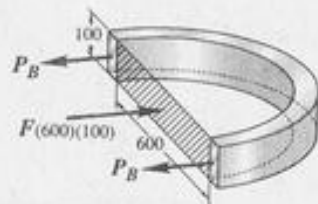

PROBLEM 266.

At 20°C , a rigid slab having a mass of 55 Mg is placed upon two bronze rods and one steel rod as shown. At what temperature will the stress in the steel rod be zero? For the steel rod, $A = 6000 \text{ mm}^2$, $E = 200 \times 10^9 \text{ N/m}^2$, and $\alpha = 11.7 \mu\text{m}/(\text{m}^\circ\text{C})$. For each bronze rod, $A = 6000 \text{ mm}^2$, $E = 83 \times 10^9 \text{ N/m}^2$, and $\alpha = 19.0 \mu\text{m}/(\text{m}^\circ\text{C})$.

Solution:

$$W = (55,000)(9.81)$$

$$W = 539,550 \text{ N}$$

When the stress in the steel rod is zero,

$$P_B = \frac{W}{2} = \frac{539,550}{2}$$

$$P_B = 269,775 \text{ N}$$

$$Y_{ts} = Y_{tB} - Y_B$$

$$(\alpha L \Delta T)_s = (\alpha L \Delta T)_B - \left(\frac{PL}{AE}\right)_B$$

$$(11.7 \times 10^{-6})(300)(T - 20^\circ) = (19 \times 10^{-6})(250)(T - 20^\circ)$$

$$= \frac{(269,775)(250)}{(6000)(83 \times 10^3)}$$

$$T = 129.2^\circ\text{C}$$

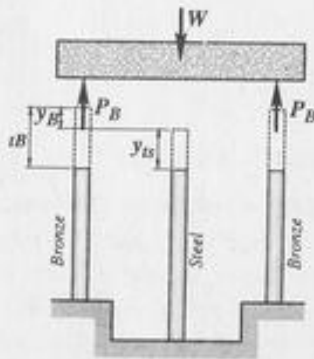
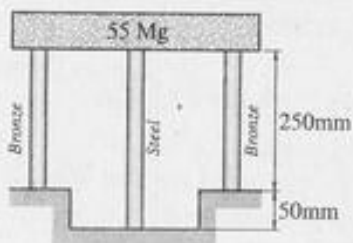

PROBLEM 267.

At 20°C , there is a gap $d = 0.2$ mm between the lower end of the bronze bar and the rigid slab supported by two steel bars, as shown. Neglecting the mass of the slab, determine the stress in each rod when the temperature of the assembly is increased to 100°C . For the bronze rod, $A = 600$ mm², $E = 83 \times 10^9$ N/m², and $\alpha = 18.9$ $\mu\text{m}/(\text{m}^\circ\text{C})$. For each steel rod, $A = 400$ mm², $E = 200 \times 10^9$ N/m², and $\alpha = 11.7$ $\mu\text{m}/(\text{m}^\circ\text{C})$.

Solution:

$$Y_t = \alpha L \Delta T$$

$$Y_{tB} = (18.9 \times 10^{-6})(800)(100^\circ - 20^\circ)$$

$$Y_{tB} = 1.2096 \text{ mm}$$

$$Y_{ts} = (11.7 \times 10^{-6})(800)(100^\circ - 20^\circ)$$

$$Y_{ts} = 0.90575 \text{ mm}$$

$$Y_{tB} = 0.20 \text{ mm} > Y_{ts}$$

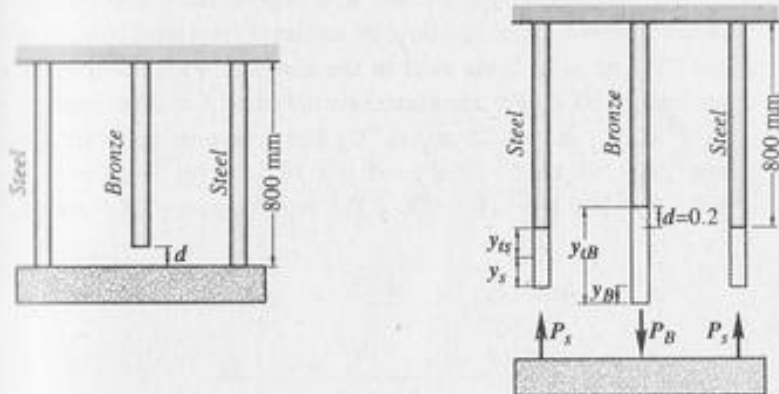

Therefore, the bronze rod will be in compression and the steel rod in tension. From FBD of slab

$$P_B = 2P_s$$

$$Y_{tB} - 0.2 = Y_B = Y_{ts} + Y_s$$

$$1.2096 - 0.2 = \frac{(PL)}{(AE)_B} = 0.90575 + \frac{(PL)}{(AE)_s}$$

$$0.10385 = \frac{P_B (800)}{(600)(83 \times 10^3)} + \frac{P_s (800)}{(400)(200 \times 10^3)}$$

$$0.10385 = \frac{(2P_s)(800)}{(600)(83 \times 10^3)} + \frac{P_s (800)}{(400)(200 \times 10^3)}$$

$$P_s = 2465 \text{ N}$$

$$P_B = 2P_s = 2(2465)$$

$$P_B = 4930 \text{ N}$$

$$S = \frac{P}{A}$$

$$S_s = \frac{2465}{400} = 6.162 \text{ MPa}$$

$$S_B = \frac{4930}{600} = 8.217 \text{ MPa}$$

An aluminum cylinder and a bronze cylinder are centered and secured between two rigid slabs by tightening two steel bolts, as shown. At 10°C no axial loads exist in the assembly. Find the stress in each material at 90°C . For the aluminum cylinder, $A = 1200 \text{ mm}^2$, $E = 70 \times 10^9 \text{ N/m}^2$, and $\alpha = 23 \text{ } \mu\text{m}/(\text{m } ^\circ\text{C})$. For the bronze cylinder, $A = 1800 \text{ mm}^2$, $E = 83 \times 10^9 \text{ N/m}^2$, and $\alpha = 19.0 \text{ } \mu\text{m}/(\text{m } ^\circ\text{C})$. For each steel bolt, $A = 500 \text{ mm}^2$, $E = 200 \times 10^9 \text{ N/m}^2$, and $\alpha = 11.7 \text{ } \mu\text{m}/(\text{m } ^\circ\text{C})$.

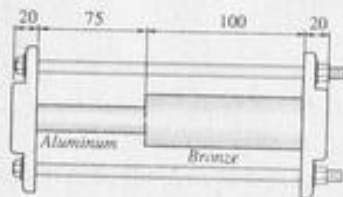

Solution:

$$Y_t = \alpha L \Delta T$$

$$Y_{tA} = (23 \times 10^{-6})(75)(90^\circ - 10^\circ)$$

$$Y_{tA} = 0.138 \text{ mm}$$

$$Y_{tB} = (19 \times 10^{-6})(100)(90^\circ - 10^\circ)$$

$$Y_{tB} = 0.152 \text{ mm}$$

$$Y_{ts} = (11.7 \times 10^{-6})(215)(90^\circ - 10^\circ)$$

$$Y_{ts} = 0.201 \text{ mm}$$

$$Y_{ts} + Y_s = (Y_{tA} + Y_{tB}) - (Y_A + Y_B)$$

$$0.201 + \frac{PL}{AE_s} = 0.138 + 0.152 - \frac{PL}{AE_A} - \frac{PL}{AE_B}$$

$$\frac{PL}{AE_s} + \frac{PL}{AE_A} + \frac{PL}{AE_B} = 0.089$$

$$\frac{P(215)}{(2500)(200 \times 10^3)} + \frac{P(75)}{1200(70 \times 10^3)} + \frac{P(100)}{1800(83 \times 10^3)}$$

$$= 0.089$$

$$P = 33,747.9 \text{ N}$$

$$S_s = \frac{33,747.9}{2(500)} = 33.75 \text{ MPa}$$

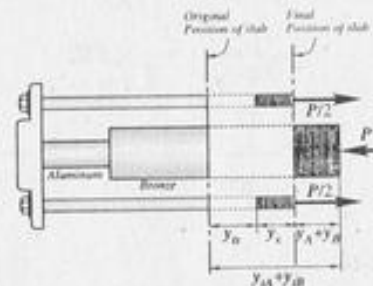

$$S_A = \frac{33,747.9}{1200} = 28.12 \text{ MPa}$$

$$S_B = \frac{33,747.9}{1800} = 18.75 \text{ MPa}$$

PROBLEM 269.

Resolve Problem 268 assuming there is a 0.05 mm gap between the right end of the bronze cylinder and the rigid slab at 10°C .

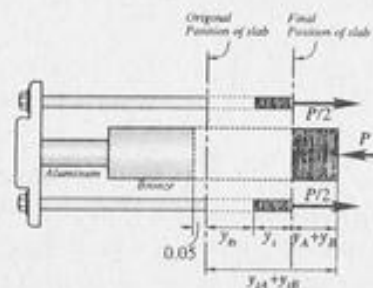

Solution:

$$Y_{ts} + Y_s = (Y_{tA} + Y_{tB}) - (Y_A + Y_B) - 0.05$$

$$0.201 + Y_s = 0.138 + 0.152 - (Y_A + Y_B) - 0.05$$

$$\frac{PL}{AE}_S + \frac{PL}{AE}_A + \frac{PL}{AE}_B = 0.039$$

$$\frac{P(215)}{2(500)(200 \times 10^3)} + \frac{P(75)}{1200(70 \times 10^3)} + \frac{P(100)}{(1800)(83 \times 10^3)} = 0.039$$

$$P = 14,788.4 \text{ N}$$

$$S_s = \frac{14,788.4}{2(500)} = 14.788 \text{ MPa}$$

$$S_A = \frac{14,788.4}{1200} = 12.324 \text{ MPa}$$

$$S_B = \frac{14,788.4}{1800} = 8.216 \text{ MPa}$$

PROBLEM 270.

A steel cylinder is enclosed in a bronze sleeve; both simultaneously support a vertical compressive load of 250 kN which is applied to the assembly through a horizontal bearing plate. The lengths of the cylinder and sleeve are equal. Compute (a) the temperature change that will cause a zero load in the steel, and (b) the temperature change that will cause a zero load in bronze. For the steel cylinder, $A = 7200 \text{ mm}^2$, $E = 200 \text{ GPa}$, and $\alpha = 11.7 \text{ } \mu\text{m}/(\text{m } ^\circ\text{C})$. For the bronze sleeve, $A = 12 \times 10^3 \text{ mm}^2$, $E = 83 \text{ GPa}$, and $\alpha = 19.0 \text{ } \mu\text{m}/(\text{m } ^\circ\text{C})$.

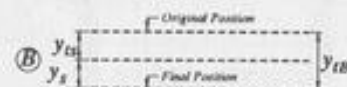
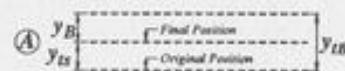
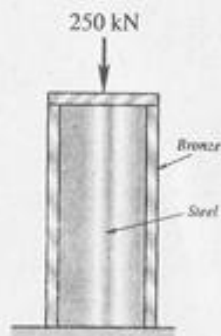

Solution:

$$(a) P_s = 0$$

$$P_B = 250,000 \text{ N}$$

$$Y_{tB} - Y_{ts} = Y_B$$

$$(19.0 \times 10^{-6})L \Delta T - (11.7 \times 10^{-6})L \Delta T = \frac{250,000(L)}{(12,000)(83 \times 10^3)}$$

$$\Delta T (19.0 \times 10^{-6} - 11.7 \times 10^{-6}) = 2.51 \times 10^{-4}$$

$$\Delta T = 34.38^\circ\text{C} \quad (\text{increase in temperature})$$

$$(b) P_B = 0$$

$$P_s = 250,000$$

$$Y_{tB} - Y_{ts} = Y_s$$

$$(19.0 \times 10^{-6})L \Delta T - (11.7 \times 10^{-6})L \Delta T = \frac{250,000 L}{7200(200 \times 10^3)}$$

$$\Delta T (19.0 \times 10^{-6} - 11.7 \times 10^{-6}) = 1.736 \times 10^{-4}$$

$$\Delta T = 23.78^\circ\text{C} \quad (\text{decrease in temperature})$$

PROBLEM 271:

A bronze sleeve is slipped over a steel bolt and is held in place by a nut that is tightened "finger-tight". Compute the temperature change which will cause the stress in the bronze to be 20 MPa. For the steel bolt, $A = 450 \text{ mm}^2$, $E = 200 \text{ GPa}$, and $\alpha = 11.7 \text{ } \mu\text{m}/(\text{m } ^\circ\text{C})$. For the bronze sleeve, $A = 900 \text{ mm}^2$, $E = 83 \text{ GPa}$, and $\alpha = 19.0 \text{ } \mu\text{m}/(\text{m } ^\circ\text{C})$.

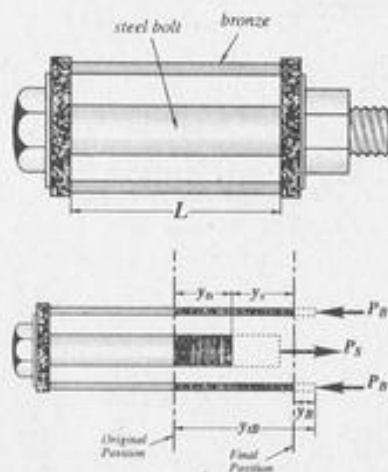

Solution:

$$S_B = 20 \text{ MPa}$$

$$P_B = A_B S_B$$

$$P_B = (900)(20)$$

$$P_B = 18,000 \text{ N}$$

$$P_S = P_B = 18,000$$

$$Y_{ts} + Y_s = Y_{tB} - Y_B$$

$$(11.7 \times 10^{-6})L \Delta T + \frac{18,000 L}{450(200 \times 10^3)}$$

$$(19.0 \times 10^{-6})L \Delta T - \frac{18,000 L}{900(83 \times 10^3)}$$

$$(19.0 \times 10^{-6} - 11.7 \times 10^{-6}) \Delta T = \frac{18,000}{450(200 \times 10^3)} + \frac{18,000}{900(83 \times 10^3)}$$

$$(7.3 \times 10^{-6}) \Delta T = 4.41 \times 10^{-4}$$

$$\Delta T = 60.41^\circ$$

PROBLEM 272.

For the sleeve-bolt assembly described in Problem 271, assume the nut is tightened to produce an initial stress of $15 \times 10^6 \text{ N/m}^2$ in the bronze sleeve. Find the stress in the bronze sleeve after a temperature rise of 70°C .

Solution:

$$S_{B_1} = 15 \text{ MPa}$$

$$P_{B_1} = S_{B_1} A_B$$

$$P_{B_1} = (15)(900)$$

$$P_{B_1} = 13,500 \text{ N}$$

$$P_{S_1} = P_{B_1}$$

$$P_{S_1} = 13,500 \text{ N}$$

$$Y_{ts} + Y_s - Y_{S_1} = Y_{B_1} + Y_{tB} - Y_B$$

$$(11.7 \times 10^{-6})L(70) + \frac{P_S L}{450(200 \times 10^3)} - \frac{13,500 L}{450(200 \times 10^3)} =$$

$$\frac{13,500 L}{900(83 \times 10^3)} + (19 \times 10^{-6})L(70) - \frac{P_B L}{900(83 \times 10^3)}$$

$$(8.19 \times 10^{-4}) + (1.111 \times 10^{-8})P_S - (1.5 \times 10^{-4}) = (1.807 \times 10^{-4})$$

$$+ (1.33 \times 10^{-3}) - (1.339 \times 10^{-8})P_B$$

$$(1.111 \times 10^{-8})P_S + (1.339 \times 10^{-8})P_B = 8.417 \times 10^{-4}$$

$$P_S = P_B$$

$$P_B(1.111 \times 10^{-8} + 1.339 \times 10^{-8}) = 8.417 \times 10^{-4}$$

$$P_B = 34,358 \text{ N}$$

$$S_B = \frac{34,358}{900} = 38.175 \text{ MPa}$$

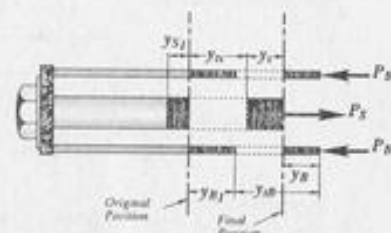

PROBLEM 273.

The composite bar shown is firmly attached to unyielding supports. An axial load $P = 200$ kN is applied at 20°C . Find the stress in each material at 60°C . Assume $\alpha = 11.7 \mu\text{m}/(\text{m}^\circ\text{C})$ for steel and $23.0 \mu\text{m}/(\text{m}^\circ\text{C})$ for aluminum.

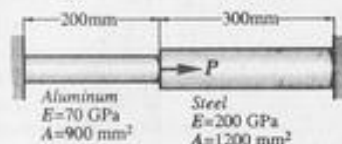

Solution:

$$Y_{tA} = \frac{(\alpha L \Delta T)}{A}$$

$$Y_{tA} = (23 \times 10^{-6})(200)(60^\circ - 20^\circ)$$

$$Y_{tA} = 0.184 \text{ mm}$$

$$Y_{ts} = (11.7 \times 10^{-6})(300)(60^\circ - 20^\circ)$$

$$Y_{ts} = 0.1404 \text{ mm}$$

$$Y_{tA} - Y_A = Y_s - Y_{ts}$$

$$0.184 - \frac{R(200)(1000)}{900(70 \times 10^3)} = \frac{(200 + R)(300)(1000)}{1200(200 \times 10^3)} - 0.1404$$

$$(200 + R)(1.25 \times 10^{-3}) + R(3.1746 \times 10^{-3}) = 0.3244$$

$$0.24 + R(1.25 \times 10^{-3}) + R(3.1746 \times 10^{-3}) = 0.3244$$

$$R(1.25 \times 10^{-3} + 3.1746 \times 10^{-3}) = 0.3244 - 0.24$$

$$R = 16.815 \text{ kN}$$

$$S_A = \frac{16.815(1000)}{900} = 18.68 \text{ MPa}$$

$$S_S = \frac{(200 \times 16.815)(1000)}{1200} = 180.68 \text{ MPa}$$

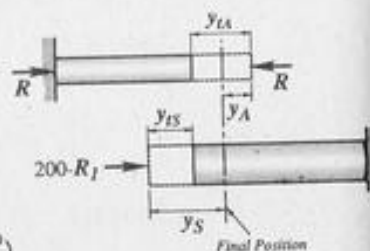

PROBLEM 274.

At what temperature will the aluminum and steel segments in Problem 273 have numerically equal stresses?

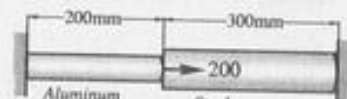

Solution:

$$\frac{S_A}{900} = \frac{S_S}{1200}$$

$$\frac{R}{900} = \frac{(200 - R)}{1200}$$

$$4R = 3(200 - R)$$

$$4R = 600 - 3R$$

$$7R = 600$$

$$R = 85.714 \text{ kN}$$

$$Y = \frac{PL}{AE}$$

$$Y_A = \frac{85.714(1000)(200)}{900(70 \times 10^3)}$$

$$Y_A = 0.2721 \text{ mm}$$

$$Y_{s'} = \frac{(200 - 85.714)(1000)(300)}{1200(200 \times 10^3)}$$

$$Y_{s'} = 0.14286 \text{ mm}$$

$$Y_A - Y_{tA} = Y_{ts} + Y_s$$

$$0.2721 - (23 \times 10^{-6})(200) \Delta T = (11.7 \times 10^{-6})(300) \Delta T + 0.14286$$

$$0.2721 - (4.6 \times 10^{-3}) \Delta T = (3.51 \times 10^{-3}) \Delta T + 0.14286$$

$$\Delta T (3.51 \times 10^{-3} + 4.6 \times 10^{-3}) = 0.12924$$

$$\Delta T = 15.94^\circ \quad (\text{decrease in temperature})$$

$$T = 20 - 15.94^\circ$$

$$T = 4.06^\circ\text{C}$$

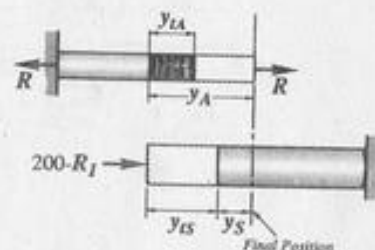

PROBLEM 275.

A rod is composed of the three segments shown. If the axial loads P_1 and P_2 are each zero, compute the stress induced in each material by a temperature drop of 30°C if (a) The walls are rigid and (b) the walls spring together by 0.300 mm . Assume $\alpha = 18.9\text{ }\mu\text{m}/(\text{m } ^\circ\text{C})$ for bronze, $23\text{ }\mu\text{m}/(\text{m } ^\circ\text{C})$ for aluminum, and $11.7\text{ }\mu\text{m}/(\text{m } ^\circ\text{C})$ for steel.

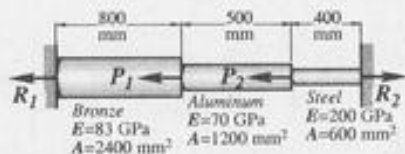

Solution:

$$(a) Y_{tB} + Y_{tA} + Y_{ts} = Y_B + Y_A + Y_s$$

$$(18.9 \times 10^{-6})(800)(30) + (23 \times 10^{-6})(500)(30) + (11.7 \times 10^{-6})(400)(30)$$

$$= \frac{R(800)}{2400(83 \times 10^3)} + \frac{R(500)}{1200(70 \times 10^3)} + \frac{R(400)}{600(200 \times 10^3)}$$

$$0.939 = (1.33 \times 10^{-5})R$$

$$R = 70,592\text{ N}$$

$$S_B = \frac{70,592}{2400} = 29.41\text{ MPa}$$

$$S_A = \frac{70,592}{1200} = 58.83\text{ MPa}$$

$$S_s = \frac{70,592}{600} = 117.65\text{ MPa}$$

$$(b) Y_{tB} + Y_{tA} + Y_{ts} = Y_B + Y_A + Y_s + 0.300$$

$$0.939 = (1.33 \times 10^{-5})R + 0.300$$

$$R = 48,045\text{ N}$$

$$S_B = \frac{48,045}{2400} = 20.0\text{ MPa}$$

$$S_A = \frac{48,045}{1200} = 40.0\text{ MPa} \quad S_s = \frac{48,045}{600} = 80.0\text{ MPa}$$

PROBLEM 276

Solve Problem 275 if P_1 and P_2 each equal 50 kN and the walls yield 0.300 mm when the temperature drops 50°C .

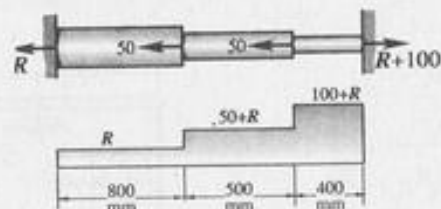

Solution:

$$Y_{tB} + Y_{tA} + Y_{ts} = Y_B + Y_A + Y_s + 0.300$$

$$(18.9 \times 10^{-6})(800)(50) + (23 \times 10^{-6})(500)(50) + (11.7 \times 10^{-6})(400)(50)$$

$$= \frac{R(1000)(800)}{2400(83 \times 10^3)} + \frac{(50 + R)(1000)(500)}{1200(70 \times 10^3)}$$

$$+ \frac{(100 + R)(1000)(400)}{600(200 \times 10^3)} + 0.300$$

$$1.265 = 0.00402R + (50 + R)(0.005952) + (100 + R)(0.00333)$$

$$1.265 = 0.013305R + 0.63060$$

$$R = 47.680\text{ kN}$$

$$50 + R = 97.680\text{ kN}$$

$$100 + R = 147.680\text{ kN}$$

$$S_B = \frac{47,680}{2400} = 19.87\text{ MPa}$$

$$S_A = \frac{97,680}{1200} = 81.40\text{ MPa}$$

$$S_s = \frac{147,680}{600} = 246.13\text{ MPa}$$

PROBLEM 277.

The rigid bar AB is pinned at O and connected to two rods as shown in the figure. If the bar AB is horizontal at a given temperature, determine the ratio of the areas of the two rods so that the bar AB will be horizontal at any temperature. Neglect the mass of bar AB.

Solution:

$$Y_{tA} = Y_A$$

$$\alpha_A L \Delta T = \frac{P_A L}{A_A E_A}$$

$$P_A = \alpha_A A_A E_A \Delta T$$

$$Y_{ts} = Y_s$$

$$\alpha_s L \Delta T = \frac{P_s L}{A_s E_s}$$

$$P_s = \alpha_s A_s E_s \Delta T$$

$$\sum M_o = 0$$

$$3P_A = 4P_s$$

$$3\alpha_A A_A E_A \Delta T = 4\alpha_s A_s E_s \Delta T$$

$$3(23)(A_A)(70) = 4(11.7)(A_s)(200)$$

$$\frac{A_s}{A_A} = 0.516$$

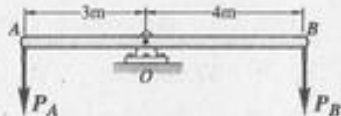
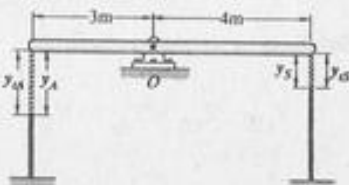
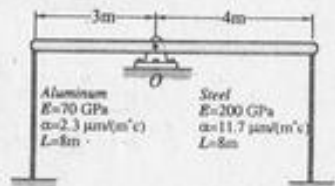

PROBLEM 278.

A rigid horizontal bar of negligible mass is connected to two rods as shown in the figure. If the system is initially stress-free, determine the temperature change that will cause a tensile stress of 60 MPa in the steel rod.

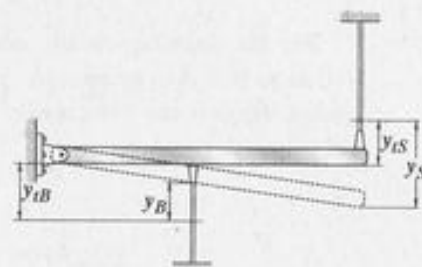
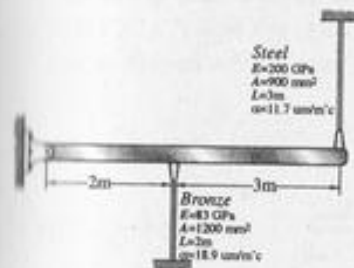

Solution:

$$\sum M_o = 0$$

$$P_B(2) = P_s(5)$$

$$A_B S_B(2) = A_s S_s(5)$$

$$(1200)(S_B)(2) = (900)(60)(5)$$

$$S_B = 112.5 \text{ MPa}$$

$$Y = \frac{SL}{E}$$

$$Y_B = \frac{(112.5)(2000)}{83 \times 10^3} = 2.711 \text{ mm}$$

$$Y_s = \frac{(60)(3000)}{200 \times 10^3} = 0.9 \text{ mm}$$

$$Y_{tB} - Y_B = Y_s - Y_{ts}$$

$$\frac{2}{5}(Y_{tB} - Y_B) = \frac{5}{2}(Y_s - Y_{ts})$$

$$5Y_{tB} - 5Y_B = 2Y_s - 2Y_{ts}$$

$$5Y_{tB} + 2Y_{ts} = 2Y_s + 5Y_B$$

$$5(18.9 \times 10^{-6})(2000) \Delta T + 2(11.7 \times 10^{-6})(3000) \Delta T = 2(0.9) + 5(2.711)$$

$$0.2592 \Delta T = 15.355$$

$$\Delta T = 59.24^\circ\text{C} \quad (\text{decrease in temperature})$$

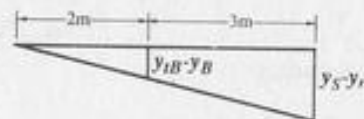

PROBLEM 279.

For the assembly shown, determine the stress in each of the two vertical rods if the temperature rises 40°C after the load $P = 50\text{ kN}$ is applied. Neglect the deformation and the mass of the horizontal bar AB.

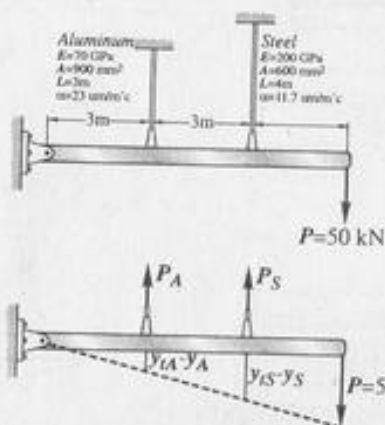

Solution:

$$\Sigma M_A = 0$$

$$P_A(3) + P_S(6) = 50(9)$$

$$P_A + 2P_S = 150; \quad P_A = 150 - 2P_S$$

$$\frac{Y_{tS} + Y_S}{6} = \frac{Y_{tA} + Y_A}{3}$$

$$Y_{tS} + Y_S = 2Y_{tA} + 2Y_A$$

$$(11.7 \times 10^{-6})(4000)(40) + \frac{P_S(1000)(4000)}{(200 \times 10^3)} =$$

$$2(23 \times 10^{-6})(300)(40) + \frac{2P_A(1000)(3000)}{900(70 \times 10^3)}$$

$$1.872 + 0.03333 P_S = 5.52 + 0.09524 P_A$$

$$0.03333 P_S - 0.09524 P_A = 3.648$$

$$0.03333 P_S - 0.09524(150 - 2P_S) = 3.648$$

$$0.22381 P_S = 17.934$$

$$P_S = 80.130\text{ kN}$$

$$P_A = 150 - 2(80.130)$$

$$P_A = -10.261\text{ kN} \quad (\text{compression})$$

$$S_A = \frac{10,261}{900} = 11.40\text{ MPa} \quad (\text{compression})$$

$$S_S = \frac{80,130}{600} = 133.55\text{ MPa} \quad (\text{tension})$$

PROBLEM 280.

The lower ends of the three steel rods shown are at the same level before the force $P = 600\text{ kN}$ is applied to the horizontal rigid slab. For each rod, $A = 2000\text{ mm}^2$, $\alpha = 11.7\text{ μm/(m }^\circ\text{C)}$, and $E = 200\text{ GPa}$. Determine the relationship between the force in rod C and the change in temperature ΔT , measured in degrees Celsius. Neglect the mass of the rigid slab.

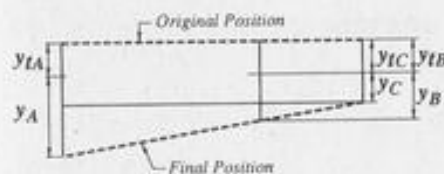
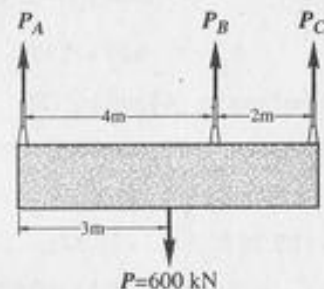
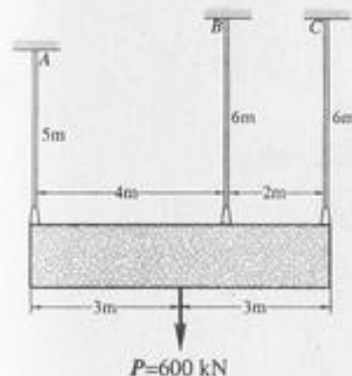

Solution:

$$\frac{(Y_B + Y_{tB}) - (Y_{tc} + Y_c)}{2} = \frac{(Y_{tA} + Y_A) - (Y_{tc} + Y_c)}{2}$$

$$3Y_B - 3Y_c = Y_{tA} + Y_A - Y_{tc} - Y_c$$

$$3Y_B - 2Y_c = Y_A + Y_{tA} - Y_{tc}$$

$$\frac{3P_B(1000)(6000)}{2000(200 \times 10^3)} - \frac{2P_c(1000)(6000)}{2000(200 \times 10^3)} = \frac{P_A(1000)(5000)}{2000(200 \times 10^3)}$$

$$+ (11.7 \times 10^{-6})(5000) \Delta T - (11.7 \times 10^{-6})(6000) \Delta T$$

$$0.045 P_B - 0.03 P_c = 0.0125 P_A - 0.0117 \Delta T$$

$$45 P_B - 30 P_c - 12.5 P_A = -11.7 \Delta T \quad (1)$$

$$\Sigma V = 0$$

$$P_A + P_B + P_C = 600 \quad (2)$$

$$12.5 P_A + 12.5 P_B + 12.5 P_C = 7500$$

$$-12.5 P_A + 45 P_B - 30 P_C = -11.7 \Delta T$$

$$57.5 P_B - 17.5 P_C = 7500 - 11.7 \Delta T \quad (3)$$

$$\Sigma M_A = 0$$

$$4P_B + 5P_C = 600(3)$$

$$4P_B = 600(3) - 5P_C$$

$$P_B = 450 - 1.5P_C \quad (4)$$

Substitute eq. (4) and eq. (3):

$$57.5(450 - 1.5P_C) - 17.5P_C = 7500 - 11.7\Delta T$$

$$25,875 - 86.25P_C - 17.5P_C = 7500 - 11.7\Delta T$$

$$-103.75 P_C = -18,375 - 11.7\Delta T$$

$$P_C = 177.11 + 0.11277 \Delta T$$

Four steel bars jointly support a mass of 15 Mg as shown in the figure. Each bar has a cross-sectional area of 600 mm^2 . Find the load carried by each bar after a temperature rise of 50°C . Assume bar after a temperature rise of 50°C . Assume $\alpha = 11.7 \text{ um}/(\text{m } ^\circ\text{C})$ and $E = 200 \times 10^9 \text{ N/m}^2$.

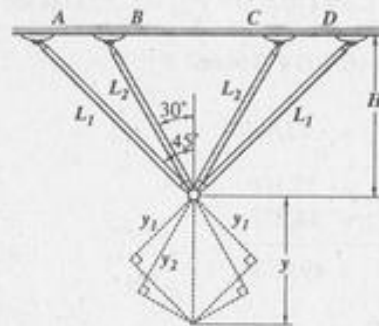
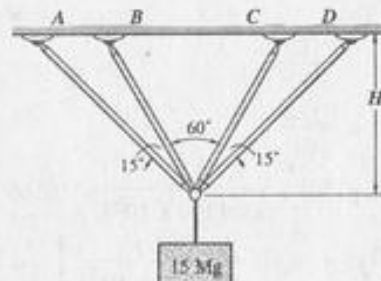

Solution:

$$W = (15 \times 10^3)(9.81) = 147,150 \text{ N}$$

$$\Sigma V = 0$$

$$2P_1 \cos 45^\circ + 2P_2 \cos 30^\circ = 147,150$$

$$0.8165 P_1 + P_2 = 84,957 \quad (1)$$

$$\begin{aligned}
 H &= L_1 \cos 45^\circ \\
 H &= L_2 \cos 30^\circ \\
 L_2 \cos 30^\circ &= L_1 \cos 45^\circ \\
 L_2 &= 0.8165 L_1 \\
 Y_1 &= Y \cos 45^\circ \\
 Y_2 &= Y \cos 30^\circ
 \end{aligned}$$

$$\frac{Y_1}{Y_2} = \frac{Y \cos 45^\circ}{Y \cos 30^\circ}$$

$$Y_1 = 0.8165 Y_2$$

$$Y_1 = \alpha L_1 \Delta T + \frac{P_1 L_1}{AE}$$

$$Y_2 = \alpha L_2 \Delta T + \frac{P_2 L_2}{AE}$$

$$(11.7 \times 10^{-6}) L_1 (50) + \frac{P_1 L_1}{600 (200 \times 10^3)} = 0.8165$$

$$\left[(11.7 \times 10^{-6}) L_2 (50) + \frac{P_2 L_2}{600 (200 \times 10^3)} \right]$$

$$70,200 L_1 + P_1 L_1 = 0.8165 (70,200 L_2 + P_2 L_2)$$

$$(70,200 + P_1) L_1 = (70,200 + P_2) 0.8165 L_2$$

$$(70,200 + P_1) L_1 = (70,200 + P_2)(0.8165)(0.8165 L_1)$$

$$70,200 + P_1 = 46,800 + 0.66667 P_2$$

$$P_1 - 0.66667 P_2 = -23,400$$

$$\begin{aligned}
 1.5 P_1 - P_2 &= -35,100 \\
 0.8165 P_1 + P_2 &= 84,957
 \end{aligned}$$

$$2.3165 P_1 = 49,857$$

$$P_1 = 21,523 \text{ N}$$

$$0.8165(21,523) + P_2 = 84,957$$

$$P_2 = 67,383 \text{ N}$$

Therefore,

$$P_A = P_P = 21,523 \text{ N} = 21.5 \text{ kN}$$

$$P_B = P_C = 67,383 \text{ N} = 67.4 \text{ kN}$$

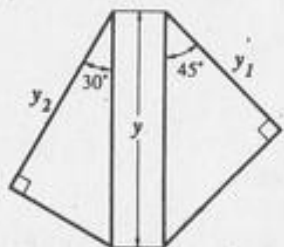
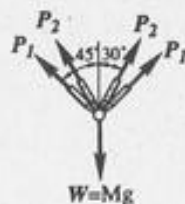

PROBLEM 282.

Solve Problem 281 if bars A and D are steel and bars B and C are aluminum. For aluminum, $\alpha = 23.0 \mu\text{m}/(\text{m}^\circ\text{C})$ and $E = 70 \times 10^9 \text{ N/m}^2$.

Solution:

$$W = (15 \times 10^3)(9.81) = 147,150 \text{ N}$$

$$\Sigma V = 0$$

$$2 P_1 \cos 45^\circ + 2 P_2 \cos 30^\circ = 147,150$$

$$0.8165 P_1 + P_2 = 84,957 \quad (1)$$

$$H = L_1 \cos 45^\circ$$

$$H = L_2 \cos 30^\circ$$

$$L_1 \cos 45^\circ = L_2 \cos 30^\circ$$

$$L_2 = 0.8165 L_1$$

$$Y_1 = Y \cos 45^\circ$$

$$Y_2 = Y \cos 30^\circ$$

$$\frac{Y_1}{Y_2} = \frac{Y \cos 45^\circ}{Y \cos 30^\circ}$$

$$Y_1 = 0.8165 Y_2$$

$$Y_1 = \alpha_1 L_1 \Delta T + \frac{P_1 L_1}{A E_1}$$

$$Y_2 = \alpha_2 L_2 \Delta T + \frac{P_2 L_2}{A E_2}$$

$$(11.7 \times 10^{-6}) L_1 (50) + \frac{P_1 L_1}{600 (200 \times 10^3)}$$

$$0.8165 \left[(23 \times 10^{-6}) L_2 (50) + \frac{P_2 L_2}{600 (70 \times 10^3)} \right]$$

$$(70,200 + P_1) L_1 = (138,000 + 2.857 P_2) 0.8165 L_2$$

$$(70,200 + P_1) L_1 = (138,000 + 2.857 P_2) (0.8165) (0.8165 L_1)$$

$$70,200 + P_1 = 92,000 + 1.905 P_2$$

$$P_1 - 1.905 P_2 = 21,800 \quad (2)$$

$$\text{Eq. (1): } (0.8165 P_1 + P_2)(1.905) = (84,957)(1.905)$$

$$1.555 P_1 + 1.905 P_2 = 161,843$$

$$\text{Eq. (2): } P_1 - 1.905 P_2 = 21,800$$

$$\frac{2.555 P_1}{} = \frac{183,643}{}$$

$$P_1 = 71,876 \text{ N}$$

$$71,876 - 1.905 P_2 = 21,800$$

$$P_2 = 26,287 \text{ N}$$

Therefore,

$$P_A = P_P = 71,876 \text{ N} = 71.9 \text{ kN}$$

$$P_B = P_C = 26,287 \text{ N} = 26.3 \text{ kN}$$

Torsion

PROBLEM 304.

What is the minimum diameter of a solid steel shaft that will not twist through more than 3° in a 6-m length when subjected to a torque of 14 kN·m? What maximum shearing stress is developed? Use $G = 83 \text{ GN/m}^2$.

Solution:

$$\theta = \frac{TL}{JG}$$

$$3 \left(\frac{\pi}{180} \right) = \frac{14(6)(1000)^3}{\frac{\pi}{32}(d^4)(83 \times 10^3)}$$

$$d = 118 \text{ mm}$$

$$S_S = \frac{16 T}{\pi d^3}$$

$$S_S = \frac{16(14)(1000)^2}{\pi(118)^3}$$

$$S_S = 43.4 \text{ MPa}$$

PROBLEM 305.

A solid steel shaft 5-m long is stressed to 60 MPa when twisted through 4° . Using $G = 83 \text{ GPa}$, compute the shaft diameter. What power can be transmitted by the shaft at 20 r/s?

Solution:

$$\theta = \frac{TL}{JG}$$

$$T = \frac{\theta JG}{L}$$

$$S_S = \frac{Tr}{J}$$

$$T = \frac{S_S J}{r}$$

$$\frac{\theta JG}{L} = \frac{S_S J}{r}$$

$$r = \frac{S_S L}{G \theta}$$

$$\frac{d}{2} = \frac{60(5,000)}{(83 \times 10^3) \left(\frac{4\pi}{180}\right)}$$

$$d = 104 \text{ mm}$$

$$S_S = \frac{16 T}{\pi d^3}$$

$$60 = \frac{16 T (1000)}{\pi (104)^3}$$

$$T = 13,252 \text{ N} \cdot \text{m}$$

$$p = T 2\pi f$$

$$p = 13,252 (2\pi) (20)$$

$$p = 1,665,295 \text{ N} \cdot \text{m}/\text{sec}$$

$$p = 1,665,295 \text{ Watts}$$

$$p = 1.665 \text{ MW}$$

PROBLEM 306.

Determine the length of the shortest 2-mm-diameter bronze wire which can be twisted through two complete turns without exceeding a shearing stress of 70 MPa. Use $G = 35 \text{ GPa}$.

Solution:

$$S_S = \frac{16 T}{\pi d^3}$$

$$70 = \frac{16 T (1000)}{\pi (2)^3}$$

$$T = 0.11 \text{ N} \cdot \text{m}$$

$$\theta = \frac{TL}{JG}$$

$$4\pi = \frac{0.11 (1000) L}{\frac{\pi}{32} (2)^4 (35 \times 10^3)}$$

$$L = 6280 \text{ mm}$$

PROBLEM 307.

A steel marine propeller is to transmit 4.5 MW at 3 r/s without exceeding a shearing stress of $50 \text{ MN}/\text{m}^2$ or twisting through more than 1° in a length of 25 diameters. Compute the proper diameter if $G = 83 \text{ GN}/\text{m}^2$.

Solution:

$$T = \frac{p}{2\pi f}$$

$$T = \frac{4.5 \times 10^6}{2\pi (3)}$$

$$T = 238,732 \text{ N} \cdot \text{m}$$

$$S = \frac{16 T}{\pi d^3}$$

$$50 = \frac{16(238,732)(1000)}{\pi d^3}$$

$$d = 290 \text{ mm}$$

$$\theta = \frac{TL}{JG}$$

$$1 \left(\frac{\pi}{180}\right) = \frac{238,732 (1000)(25 d)}{\frac{\pi d^4}{32} (83 \times 10^3)}$$

$$d = 347.5 \text{ mm}$$

$$\text{Use } d = 348 \text{ mm}$$

PROBLEM 308.

Show that a hollow circular shaft whose inner diameter is half the outer diameter has a torsional strength equal to 15/16 of that of a solid shaft of the same outside diameter.

Solution:

$$S_S = \frac{T r}{J}$$

For solid shaft:

$$J = \frac{\pi}{32} d^4$$

For hollow shaft:

$$J = \frac{\pi}{32} (d^4 - D^4)$$

$$J = \frac{\pi}{32} \left[d^4 - \left(\frac{d}{2}\right)^4 \right]$$

$$J = \frac{\pi}{32} \left[d^4 - \frac{d^4}{16} \right]$$

$$J = \frac{\pi}{32} \left(\frac{15}{16} d^4 \right)$$

Let S = maximum allowable stress of the shaft material. The torque capacity of the shaft is that value which will cause stresses approaching the maximum allowable. The capacity is the measure of strength. For the solid shaft:

$$S = \frac{T_S \left(\frac{d}{2}\right)}{\frac{\pi}{32} d^4}$$

$$S = \frac{16 T_S}{\pi d^3}$$

For the hollow shaft:

$$S = \frac{T_h \left(\frac{d}{2}\right)}{\frac{\pi}{32} \left(\frac{15}{16} d^4\right)}$$

$$S = \frac{16 T_h}{\pi \frac{15}{16} d^3}$$

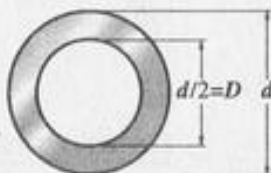

$$\frac{16 T_h}{\frac{15}{16} \pi d^3} = \frac{16 T_S}{\pi d^3}$$

$$T_h = \frac{15}{16} T_S$$

Therefore, the torque capacity (or torsional strength) of the hollow shaft is 15/16 of that of the solid shaft.

PROBLEM 310.

Determine the maximum torque that can be applied to a hollow circular steel shaft of 100-mm outside diameter and 70-mm inside diameter without exceeding a shearing stress of $60 \times 10^6 \text{ N/m}^2$ or a twist of 0.5 deg/m. Use $G = 83 \times 10^9 \text{ N/m}^2$.

Solution:

$$J = \frac{\pi}{32} (D^4 - d^4)$$

$$J = \frac{\pi}{32} [(100)^4 - (70)^4]$$

$$J = 7.460 \times 10^6 \text{ mm}^4$$

$$S_S = \frac{T r}{J}$$

$$60 = \frac{T (50) (1000)}{7.460 \times 10^6}$$

$$T = 8,952 \text{ N} \cdot \text{m}$$

$$\theta = \frac{T L}{J G}$$

$$0.5 \left(\frac{\pi}{180}\right) = \frac{T (1000)^2}{(7.460 \times 10^6) (83 \times 10^3)}$$

$$T = 5,403 \text{ N} \cdot \text{m}$$

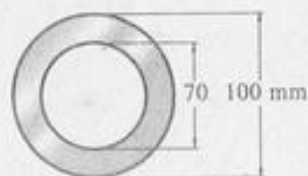

PROBLEM 311.

A stepped steel shaft consists of a hollow shaft 2 m long, with an outside diameter of 100 mm and an inside diameter of 70 mm, rigidly attached to a solid shaft 1.5 m long, and 70 mm in diameter. Determine the maximum torque which can be applied without exceeding a shearing stress of 70 MN/m^2 or a twist of 2.5 deg in the 3.5 m length. Use $G = 83 \text{ GN/m}^2$.

Solution:

For hollow shaft:

$$J = \frac{\pi}{32} (D^4 - d^4)$$

$$J = \frac{\pi}{32} [(100)^4 - (70)^4]$$

$$J = 7.460 \times 10^6 \text{ mm}^4$$

$$S_S = \frac{T r}{J}$$

$$70 = \frac{T (50) (1000)}{7.460 \times 10^6}$$

$$T = 10,444 \text{ N} \cdot \text{m}$$

For solid shaft:

$$J = \frac{\pi}{32} (70)^4$$

$$J = 2.357 \times 10^6 \text{ mm}^4$$

$$S_S = \frac{T r}{J}$$

$$70 = \frac{T (1000)(35)}{2.357 \times 10^6}$$

$$T = 4,714 \text{ N} \cdot \text{m}$$

$$\theta = \sum \frac{TL}{JG}$$

$$2.5 \left(\frac{\pi}{180} \right) = \frac{T (1000)}{83 \times 10^3} \left[\frac{2,000}{7.460 \times 10^6} + \frac{1,5000}{2.357 \times 10^6} \right]$$

$$T = 4,004 \text{ N} \cdot \text{m}$$

$$\text{Max. Torque} = 4,004 \text{ N} \cdot \text{m}$$

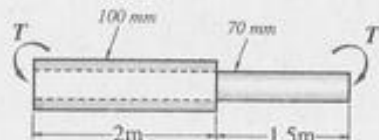

PROBLEM 312.

A flexible shaft consists of a 5-mm-diameter steel wire encased in a stationary tube that fits closely enough to impose a frictional torque of 2 N·m/m. Determine the maximum length of the shaft if the shearing stress is not to exceed 140 MPa. What will be the angular rotation of one end relative to the other end? Use $G = 83 \text{ GPa}$.

Solution:

$$a) S_S = \frac{16 T}{\pi d^3}$$

$$140 = \frac{16 (2 L) (1000)}{\pi (5)^3}$$

$$L = 1.718 \text{ m}$$

$$b) \theta = \frac{TL}{JG}$$

$$d\theta = \int_0^L \frac{(2L) dL}{\frac{\pi}{32} (5)^4 (83 \times 10^3)} \quad \left[\frac{180}{\pi} (1000)^2 \right]$$

$$\theta = \frac{(180)(1000)(32)(2)}{(\pi)^2 (5)^4 (83 \times 10^3)} \left[\frac{L^2}{2} \right]_{0}^{1.718}$$

$$\theta = \frac{(180)(32)(1000)}{(\pi)^2 (5)^4 (83)} [1.718]^2$$

$$\theta = 33.21^\circ$$

PROBLEM 313:

The steel shaft shown rotates at 3 r/s with 30 kW taken off at A, 15 kW removed at B, and 45 kW applied at C. Using $G = 83 \times 10^9 \text{ N/m}^2$, find the maximum shearing stress and the angle of rotation of gear A relative to gear C.

Solution:

$$T = \frac{P}{2\pi f}$$

$$T_{AB} = \frac{30}{2\pi(3)}$$

$$T_{AB} = 1.592 \text{ kN}\cdot\text{m}$$

$$T_{BC} = \frac{45}{2\pi(3)}$$

$$T_{BC} = 2.387 \text{ kN}\cdot\text{m}$$

$$S_S = \frac{16T}{\pi d^3}$$

for AB:

$$S_S = \frac{16(1.592)(1000)^2}{\pi(50)^3}$$

$$S_S = 64.86 \text{ MPa}$$

for BC:

$$S_S = \frac{16(2.387)(1000)^2}{\pi(75)^3}$$

$$S_S = 28.82 \text{ MPa}$$

$$\max S_S = 64.86 \text{ MPa}$$

$$\theta_{A/C} = \sum \frac{TL}{JG} = \frac{180}{\pi}$$

$$\theta_{A/C} = \frac{180}{\pi(83 \times 10^3)} \left[\frac{(1.592)(4)(1000)^3}{\frac{\pi}{32}(50)^4} + \frac{(2.387)(2)(1000)^3}{\frac{\pi}{32}(75)^4} \right]$$

$$\theta_{A/C} = 8.225^\circ$$

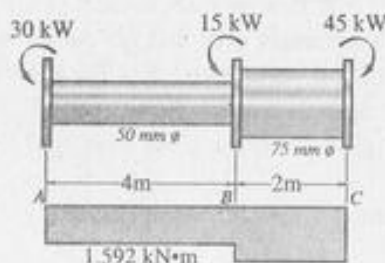

PROBLEM 314.

A solid steel shaft is loaded as shown. Using $G = 83 \text{ GN/m}^2$, determine the required diameter of the shaft if the shearing stress is limited to 60 MN/m^2 and the angle of rotation at the free end is not to exceed 4° .

Solution:

$$S_S = \frac{16T}{\pi d^3}$$

$$60 = \frac{16(1000)(1000)}{\pi d^3}$$

$$d = 43.9 \text{ mm}$$

$$\theta = \sum \frac{TL}{JG} = \frac{180}{\pi}$$

$$4 = \frac{180}{\pi} \cdot \frac{1}{\left(\frac{\pi}{32}d^4\right)(83 \times 10^3)} [1000(3)(1000)^2 + 500(2)(1000)^2]$$

$$d = 51.5 \text{ mm}$$

$$\text{Use } d = 51.5 \text{ mm}$$

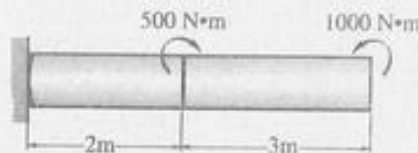

PROBLEM 315:

A 5-m steel shaft rotating at 2 r/s has 70 kW applied at a gear that is 2 m from the left end where 20 kW are removed. At the right end, 30 kW are removed and another 20 kW leaves the shaft at 1.5 m from the right end. a) Find the uniform shaft diameter so that the shearing stress will not exceed 60 MN/m^2 . (b) If a uniform shaft diameter of 100 mm is specified, determine the angle by which one end of the shaft lags behind the other end. Use $G = 83 \text{ GN/m}^2$.

Solution:

$$T = \frac{P}{2\pi f}$$

$$T_{AB} = \frac{20}{2\pi(2)} = 1.592 \text{ kN}\cdot\text{m}$$

$$T_{BC} = \frac{50}{2\pi(2)} = 3.979 \text{ kN}\cdot\text{m}$$

$$T_{CD} = \frac{30}{2\pi(2)} = 2.387 \text{ kN}\cdot\text{m}$$

$$a) S_S = \frac{16 T}{\pi d^3}$$

$$60 = \frac{16 (3.979)(1000)^2}{\pi (d^3)}$$

$$d = 69.64 \text{ mm}$$

$$b) \theta = \Sigma \frac{TL}{JG} = \frac{180}{\pi}$$

$$\theta_{D/A} = \frac{180}{\pi} \frac{(1000)^3}{\frac{\pi}{32} (100)^4 (83 \times 10^3)} [(2.387)(1.5) + 3.979(1.5) - (1.592)(2)]$$

$$\theta_{D/A} = 0.448^\circ$$

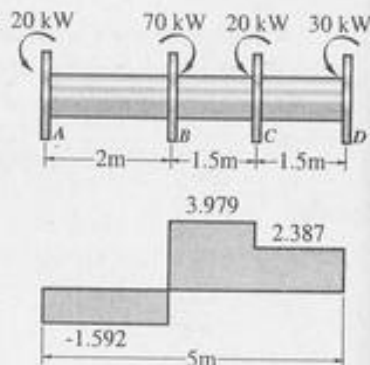

PROBLEM 316.

A round steel shaft 3 m long tapers uniformly from a 60-mm diameter at one end to a 30-mm diameter at the other end. Assuming that no significant discontinuity results from applying the angular deformation equation over each infinitesimal length, compute the angular twist for the entire length when the shaft is transmitting a torque of 170 N·m. Use $G = 83 \times 10^3 \text{ MN/m}^2$.

Solution:

$$\frac{y}{30} = \frac{y+3}{60}$$

$$y = 3 \text{ m}$$

$$\frac{D}{30} = \frac{x}{3}$$

$$D = 10x \text{ mm}$$

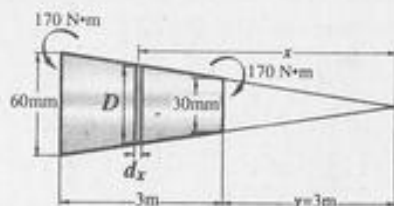

$$J_S = 0.614 \times 10^6 \text{ mm}^4$$

$$\theta = \frac{TL}{JG}$$

$$\theta_B = \theta_S$$

$$\frac{T_B L}{(2.493)(35)} = \frac{T_S L}{(0.614)(83)}$$

$$T_B = 1.712 T_S$$

$$T_B + T_S = 3$$

$$1.712 T_S + T_S = 3$$

$$T_S = 1.106 \text{ kN}\cdot\text{m}$$

$$T_B = 1.894 \text{ kN}\cdot\text{m}$$

$$S_S = \frac{T r}{J}$$

for Bronze:

$$S_S = \frac{1.894(37.5)(1000)^2}{2.493 \times 10^6}$$

$$S_S = 28.49 \text{ MPa}$$

for Steel:

$$S_S = \frac{1.106(25)(1000)^2}{0.614 \times 10^6}$$

$$S_S = 45.03 \text{ MPa}$$

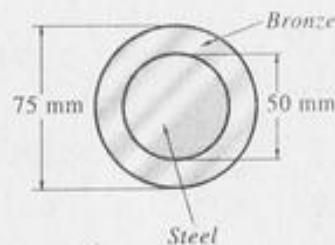
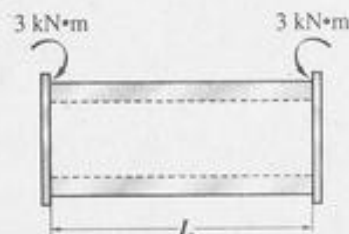

PROBLEM 318.

A solid compound shaft is made of three different materials and is subjected to two applied torques as shown. (a) Determine the maximum shearing stress developed in each material. (b) Find the angle of rotation of the free end of the shaft. Use $G_a = 28 \text{ GN/m}^2$, $G_s = 83 \text{ GN/m}^2$, and $G_b = 35 \text{ GN/m}^2$.

$$\theta = \frac{TL}{JG}$$

$$\theta = \int_3^6 \frac{T dx}{JG}$$

$$\theta = \int_3^6 \frac{(170 dx)(1000)^2}{\left(\frac{\pi}{32} D^4\right) (83 \times 10^3)}$$

$$\theta = \frac{170,000 (32)}{83 \pi} \int_3^6 \frac{dx}{(10x)^4}$$

$$\theta = 2.08627 \int_3^6 x^{-4} dx$$

$$\theta = 2.08627 \left[\frac{x^{-3}}{-3} \right]_3^6$$

$$\theta = -0.69542 \left[\frac{1}{x^3} \right]_3^6$$

$$\theta = -0.69542 \left[\frac{1}{(6)^3} - \frac{1}{(3)^3} \right]$$

$$\theta = 0.02254 \text{ rad} \quad \frac{180}{\pi}$$

$$\theta = 1.291^\circ$$

PROBLEM 317.

A hollow bronze shaft of 75 mm outer diameter and 50 mm inner diameter is slipped over a solid steel shaft 50 mm in diameter and of the same length as the hollow shaft. The two shafts are then fastened rigidly together at their ends. Determine the maximum shearing stress developed in each material by end torques of 3 kN·m. For bronze, $G = 35 \text{ GN/m}^2$; for steel, $G = 83 \text{ GN/m}^2$.

Solution:

$$J_B = \frac{\pi}{32} [(75)^4 - (50)^4]$$

$$J_B = 2.493 \times 10^6 \text{ mm}^4$$

$$J_S = \frac{\pi}{32} (50)^4$$

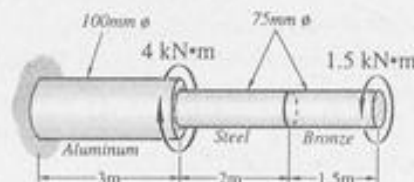

Solution:

$$a) S_s = \frac{16 T}{\pi d^3}$$

For bronze:

$$S_s = \frac{16(1.5)(1000)^2}{\pi (75)^3}$$

$$S_s = 18.11 \text{ MPa}$$

For steel:

$$S_s = \frac{16(1.5)(1000)^2}{\pi (75)^3}$$

$$S_s = 18.11 \text{ MPa}$$

For aluminum:

$$S_s = \frac{16(2.5)(1000)^2}{\pi (100)^3}$$

$$S_s = 12.73 \text{ MPa}$$

$$b) \theta = \sum \frac{TL}{JG} = \frac{180}{\pi}$$

$$\theta = \left[\frac{1.5(1.5)(1000)^3}{\frac{\pi}{32}(75)^4(35 \times 10^3)} + \frac{1.5(2)(1000)^3}{\frac{\pi}{32}(75)^4(83 \times 10^3)} \right. \\ \left. - \frac{2.5(3)(1000)^3}{\frac{\pi}{32}(100)^4(28 \times 10^3)} \right] \frac{180}{\pi}$$

$$\theta = 0.2892^\circ$$

$$M_B = \frac{2}{2}(42 + 2) = 44 \text{ KN}\cdot\text{m}$$

$$M_C = 44 - 38(2) = -32 \text{ KN}\cdot\text{m}$$

$$M_H = -32 + 32(1) = 0 \text{ (check)}$$

$$M_D = 0 + 32(1) = 32 \text{ KN}\cdot\text{m}$$

$$M_F = 32 + \frac{1}{2}(1.6)(32)$$

$$M_F = 57.6 \text{ KN}\cdot\text{m}$$

$$M_E = 57.6 - \frac{1}{2}(48)(2.4)$$

$$M_E = 0$$

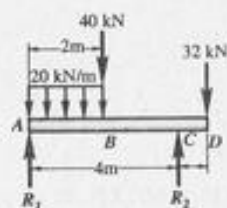
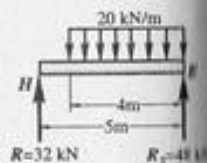

PROBLEM 441. A beam ABCD is supported by a hinge at A and a roller at D. It is subjected to the loads shown which act at the ends of the vertical members BE and CF. These vertical members are rigidly attached to the beam at B and C. Draw shear & moment diagram for beam ABCD only.

Sol'n.

$$\sum M_A = 0$$

$$D_V(7) + 4(2) + 3(2) = 14(2)$$

$$D_V = 2 \text{ KN}$$

$$A_V = 4 + 2 = 6 \text{ KN}$$

$$A_H = 3 + 14 = 17 \text{ KN}$$

$$M_B = -6(2) = -12 \text{ KN}\cdot\text{m}$$

$$M_{B^1} = -12 - 6 = -18 \text{ KN}\cdot\text{m}$$

$$M_C = -18 - 2(2) = -22 \text{ KN}\cdot\text{m}$$

$$M_{C^1} = -22 + 28 = 6 \text{ KN}\cdot\text{m}$$

$$M_D = 6 - 2(3) = 0$$

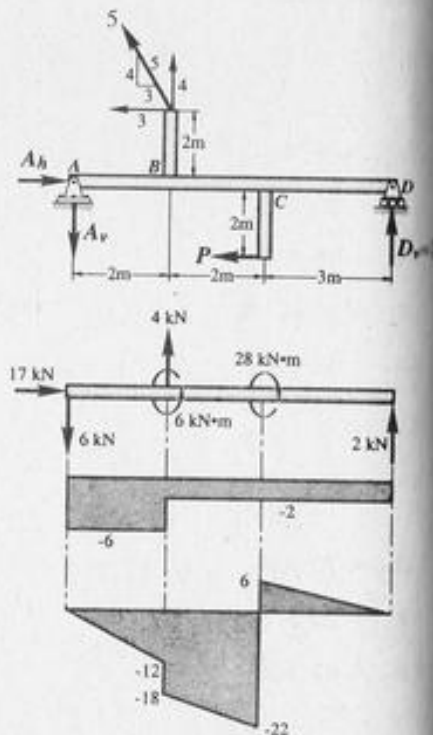

PROBLEM 442.

$$\sum MR_1 = 0$$

$$R_2 L = \frac{1}{2} WL \left(\frac{2}{3} L \right)$$

$$R_2 = \frac{WL}{3}$$

$$R_1 = \frac{WL}{2} - \frac{WL}{3}$$

$$R_1 = \frac{WL}{6}$$

$$y = \frac{WX}{L}$$

max, M is at $V = 0$

$$\frac{WL}{6} - \frac{1}{2} Xy = 0$$

$$\frac{WL}{6} - \frac{1}{2} X \left(\frac{WX}{L} \right) = 0$$

$$\frac{L}{3} - \frac{X^2}{L} = 0$$

$$X^2 = \frac{L^2}{3}$$

$$X = \frac{L}{\sqrt{3}}$$

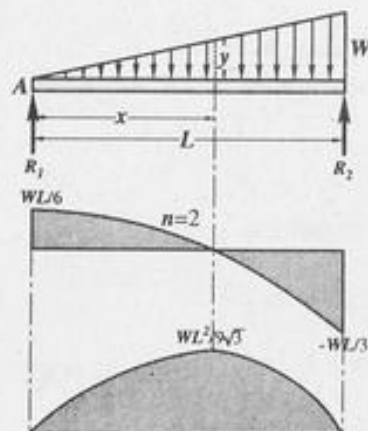

PROBLEM 319.

The compound shaft shown is attached to rigid supports. For the bronze segment AB, the diameter is 75 mm, $S \leq 60 \text{ MN/m}^2$, and $G = 35 \text{ GN/m}^2$. For the steel segment BC, the diameter is 50 mm, $S \leq 80 \text{ MN/m}^2$, and $G = 83 \text{ GN/m}^2$. If $a = 2 \text{ m}$ and $b = 1.5 \text{ m}$, compute the maximum torque T that can be applied.

Solution:

$$S = \frac{T r}{J}$$

$$S = \frac{T d}{2J}$$

$$T = \frac{2JS}{d}$$

$$\theta = \frac{TL}{JG}$$

$$\theta_B = \theta_S$$

$$\frac{TL}{JG}_B = \frac{TL}{JG}_S$$

$$\frac{2JSL}{dJG}_B = \frac{2JSL}{dJG}_S$$

$$\frac{SL}{DG}_B = \frac{SL}{dg}_S$$

$$\frac{S_B(2)}{75(35)} = \frac{S_S(1.5)}{50(83)}$$

$$S_B = 0.4744 S_S$$

when $S_S = 80 \text{ MPa}$

$$S_B = 0.4744(80)$$

$$S_B = 37.95 \text{ MPa} < 60 \text{ MPa (Ok)}$$

when $S_B = 60 \text{ MPa}$

$$60 = 0.4744 S_S$$

$$S_S = 126.48 \text{ MPa} > 80 \text{ MPa (Fail)}$$

Use: $S_S = 80 \text{ MPa}$
 $S_B = 37.95 \text{ MPa}$

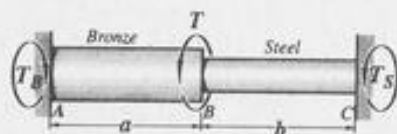

$$S = \frac{16 T}{\pi d^3}$$

For bronze:

$$37.95 = \frac{16 T_B(1000)}{\pi (75)^3}$$

$$T_B = 3143.6 \text{ N.m}$$

For steel:

$$80 = \frac{16 T_S(1000)}{\pi (50)^3}$$

$$T_S = 1963.5 \text{ N.m}$$

$$T = T_S + T_B$$

$$T = 1963.5 + 3143.6$$

$$T = 5107.1 \text{ N.m}$$

PROBLEM 320.

In problem 319, determine the ratio of the lengths b/a so that each material will be stressed to its permissible limit. What torque T is required.

Solution:

$$\frac{SL}{dG}_B = \frac{SL}{dG}_S$$

$$\frac{60(a)}{75(35)} = \frac{80(b)}{50(83)}$$

$$\frac{b}{a} = 1.186$$

$$S = \frac{16 T}{\pi d^3}$$

For bronze:

$$60 = \frac{16 T_B (1000)^2}{\pi (75)^3}$$

$$T_B = 4.970 \text{ kN} \cdot \text{m}$$

For steel:

$$80 = \frac{16 T_S (1000)^2}{\pi (50)^3}$$

$$T_S = 1.963 \text{ kN} \cdot \text{m}$$

$$T = T_B + T_S$$

$$T = 4.970 + 1.963$$

$$T = 6.933 \text{ kN} \cdot \text{m}$$

PROBLEM 321.

A compound shaft consisting of an aluminum segment and a steel segment is acted upon by two torques as shown. Determine the maximum permissible value of T subject to the following conditions: $S_S \leq 100 \text{ MPa}$, $S_a \leq 70 \text{ MPa}$, and the angle of rotation of the free end is limited to 12° . Use $G_s = 83 \text{ GPa}$ and $G_a = 28 \text{ GPa}$.

Solution:

$$S = \frac{16 T}{\pi d^3}$$

$$100 = \frac{16 (2T)(1000)}{\pi (50)^3}$$

$$T = 1227 \text{ N} \cdot \text{m}$$

$$70 = \frac{16 (3T)(1000)}{\pi (75)^3}$$

$$T = 1933 \text{ N} \cdot \text{m}$$

$$\theta = \sum \frac{TL}{JG}$$

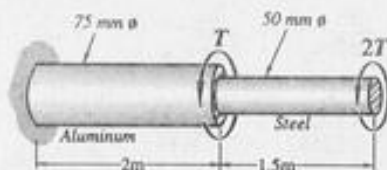

$$12 \cdot \frac{\pi}{180} = \frac{2T (1.5)(1000)^2}{\frac{\pi}{32} (50)^4 (83 \times 10^3)} + \frac{3T (2)(1000)^2}{\frac{\pi}{32} (75)^4 (28 \times 10^3)}$$

$$T = 1637.6 \text{ N} \cdot \text{m}$$

max. permissible value of $T = 1227 \text{ N} \cdot \text{m}$

PROBLEM 322.

A torque T is applied as shown to a solid shaft with built-in ends. Prove that the resisting torques at the walls are $T_1 = Tb/L$ and $T_2 = Ta/L$. How would these values be changed if the shaft were hollow?

Solution:

$$\theta_1 = \theta_2$$

$$\frac{T_1 L_1}{J_1 G_1} = \frac{T_2 L_2}{J_2 G_2}$$

$$T_1 (a) = T_2 (b)$$

$$T_1 = \frac{b}{a} T_2$$

$$T_1 + T_2 = T$$

$$\frac{b}{a} T_2 + T_2 = T$$

$$b T_2 + a T_2 = a T$$

$$T_2 (a + b) = Ta$$

$$T_2 = \frac{Ta}{L}$$

$$T_2 = \frac{b}{a} \frac{Ta}{L}$$

$$T_1 = \frac{Tb}{L}$$

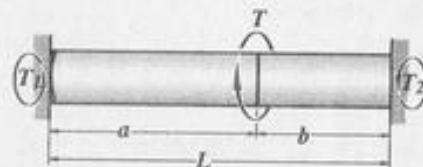

If the shaft were hollow, the same relations would result because J and G are still the same for both segments.

PROBLEM 323.

A shaft 100 mm in diameter and 3 m long, with built-in ends, is subjected to a clockwise torque of 4 kN·m applied 1 m from the left end, and to another clockwise torque of 16 kN·m applied 2 m from the left end. Compute the maximum shearing stress developed in each segment of the shaft.

Solution:

$$T_1 = \Sigma \frac{Tb}{L}$$

$$T_1 = \frac{4(2)}{3} + \frac{16(1)}{3}$$

$$T_1 = 8 \text{ kN} \cdot \text{m}$$

$$T_2 = \Sigma \frac{Ta}{L}$$

$$T_2 = \frac{4(1)}{3} + \frac{16(2)}{3}$$

$$T_2 = 12 \text{ kN} \cdot \text{m}$$

$$S_s = \frac{16 T}{\pi d^3}$$

For AB: $T = 8 \text{ kN} \cdot \text{m}$

$$S_s = \frac{16(8)(1000)^2}{\pi (100)^3}$$

$$S_s = 40.74 \text{ MPa}$$

For BC: $T = 8 - 4$

$$T = 4 \text{ kN} \cdot \text{m}$$

$$S_s = \frac{16(4)(1000)^2}{\pi (100)^3}$$

$$S_s = 20.37 \text{ MPa}$$

For CD: $T = 12 \text{ kN} \cdot \text{m}$

$$S_s = \frac{16(12)(1000)^2}{\pi (100)^3}$$

$$S_s = 61.12 \text{ MPa}$$

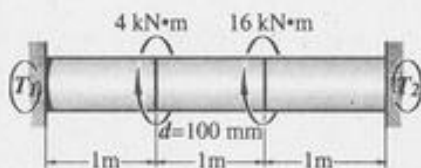

PROBLEM 324.

A shaft composed of segments AC, CD, and DB is fastened to rigid supports and loaded as shown. For steel, $G = 83 \text{ GN/m}^2$; for aluminum, $G = 28 \text{ GN/m}^2$; and for bronze, $G = 35 \text{ GN/m}^2$. Determine the maximum shearing stress developed in each segment.

Solution:

$$\theta_{A/B} = 0$$

$$\theta_{A/B} = \Sigma \frac{TL}{JG}$$

$$0 = \frac{T_A(2)(1000)^2}{\frac{\pi}{32}(25)^4(83 \times 10^3)} + \frac{(T_A - 300)(1.5)(1000)^2}{\frac{\pi}{32}(50)^4(28 \times 10^3)}$$

$$- \frac{(T_A - 1000)(1)(1000)^2}{\frac{\pi}{32}(25)^4(35 \times 10^3)}$$

$$\frac{T_A(2)}{(25)^4(83)} + \frac{(T_A - 300)(1.5)}{(50)^4(28)} - \frac{(1000 - T_A)}{(25)^4(35)} = 0$$

$$10.795 T_A + 1.5 T_A - 450 + 12.8 T_A - 12,800 = 0$$

$$25.095 T_A - 13,250 = 0$$

$$T_A = 528 \text{ N} \cdot \text{m}$$

$$T_A + T_B = 300 + 700$$

$$T_B = 1000 - 528$$

$$T_B = 472 \text{ N} \cdot \text{m}$$

$$T_{AC} = 528 \text{ N} \cdot \text{m}$$

$$T_{CD} = 528 - 300 = 228 \text{ N} \cdot \text{m}$$

$$T_{DB} = 472 \text{ N} \cdot \text{m}$$

$$S = \frac{16 T}{\pi d^3}$$

For steel:

$$S_S = \frac{16(528)(1000)}{\pi(25)^3}$$

$$S_S = 172.10 \text{ MPa}$$

For aluminum:

$$S_a = \frac{16(228)(1000)}{\pi(50)^3}$$

$$S_a = 9.29 \text{ MPa}$$

For Bronze:

$$S_b = \frac{16(472)(1000)}{\pi(25)^3}$$

$$S_b = 153.85 \text{ MPa}$$

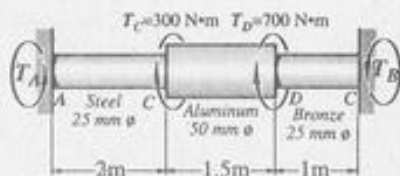

PROBLEM 325.

The two steel shafts shown in the figure, each with one end built into a rigid support, have flanges rigidly attached to their free ends. The shafts are to be bolted together at their flanges. However, initially there is a 6° mismatch in the location of the bolt holes, as shown in the figure. Determine the maximum shearing stress in each shaft after the shafts are bolted together. Use $G = 83 \text{ GN/m}^2$ and neglect deformations of the bolts and flanges.

Solution:

$$\theta_1 + \theta_2 = 6^\circ$$

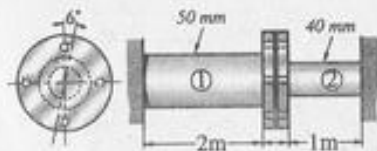

$$\frac{T(2)(1000)^2}{\frac{\pi}{32}(50)^4(83 \times 10^3)} + \frac{T(1)(1000)^2}{\frac{\pi}{32}(40)^4(83 \times 10^3)} = 6 \frac{\pi}{180}$$

$$T = 1200.8 \text{ N} \cdot \text{m}$$

$$S_S = \frac{16T}{\pi d^3}$$

$$S_{S1} = \frac{16(1200.8)(1000)}{\pi(50)^3} = 48.92 \text{ MPa}$$

$$S_{S2} = \frac{16(1200.8)(1000)}{\pi(40)^3} = 95.56 \text{ MPa}$$

FLANGED BOLT COUPLINGS

PROBLEM 326.

A flanged bolt coupling consists of eight steel 20-mm-diameter bolts spaced evenly around a bolt circle 300 mm in diameter. Determine the torque capacity of the coupling if the allowable shearing stress in the bolts is 40 MN/m^2 .

Solution:

$$T = PRn$$

$$T = \frac{\pi d^2}{4} S_S Rn$$

$$T = \frac{\pi(20)^2}{4} (40)(0.150)(8)$$

$$T = 15,080 \text{ N} \cdot \text{m}$$

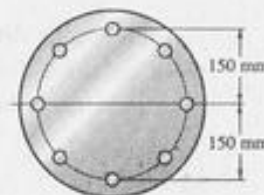

PROBLEM 328.

A flanged bolt coupling consists of six 10-mm-diameter steel bolts on a bolt circle 300 mm in diameter, and four 10-mm-diameter steel bolts on a concentric bolt circle 200 mm in diameter, as shown in the figure. What torque can be applied without exceeding a shearing stress of 60 MPa in the bolts?

Solution:

$$P_1 = \frac{\pi d^2}{4} S_S$$

$$P_1 = \frac{\pi}{4} (10)^2 (60)$$

$$P_1 = 4712.4 \text{ N}$$

$$\frac{P_1}{R_1} = \frac{P_2}{R_2}$$

$$P_2 = \frac{4712.4(100)}{150}$$

$$P_2 = 3141.6 \text{ N}$$

$$T = P_1 R_1 n_1 + P_2 R_2 n_2$$

$$T = 4712.4(0.15)(6) + 3141.6(0.10)(4)$$

$$T = 5497.8 \text{ N}\cdot\text{m}$$

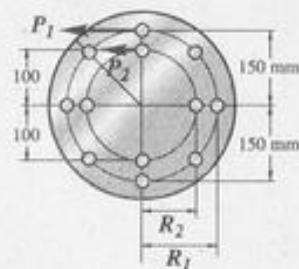

PROBLEM 329.

Determine the number of 10-mm-diameter steel bolts that must be used on the 300-mm bolt circle of the coupling described in Problem 328 to increase the torque capacity to 8 kN·m.

Solution:

$$T = P_1 R_1 n_1 + P_2 R_2 n_2$$

$$8000 = 4712.4 (0.15)(n_1) + 3141.6(0.10)(4)$$

$$n_1 = 9.5, \quad \text{say 10 bolts}$$

PROBLEM 327.

A flanged bolt coupling is used to connect a solid shaft 90 mm in diameter to a hollow shaft 100 mm in outside diameter and 90 mm in inside diameter. If the allowable shearing stress in the shafts and the bolts is 60 MN/m², how many 10-mm-diameter steel bolts must be used on a 200-mm-diameter bolt circle so that the coupling will be as strong as the weaker shaft?

Solution:

For solid shaft:

$$S_S = \frac{16 T}{\pi d^3}$$

$$60 = \frac{16 T (1000)}{\pi (90)^3}$$

$$T = 8588.3 \text{ N}\cdot\text{m}$$

For hollow shaft:

$$S_S = \frac{T r}{J}$$

$$r = 50 \text{ mm}$$

$$J = \frac{\pi}{32} [(100)^4 - (90)^4]$$

$$J = 3,376,230 \text{ mm}^4$$

$$60 = \frac{T(1000)(50)}{3,376,230}$$

$$T = 4051.5 \text{ N}\cdot\text{m}$$

$$\text{Use } T = 4051.5 \text{ N}\cdot\text{m}$$

$$T = \frac{\pi d^2}{4} S_S R n$$

$$4051.5 = \frac{\pi (10)^2}{4} (60)(0.100)(n)$$

$$n = 8.6, \quad \text{say 9 bolts}$$

PROBLEM 330.

Solve problem 328 if the diameter of the bolts used on the 200-mm bolt circle is changed to 20 mm.

Solution:

$$P_1 = \frac{\pi d^2}{4} S_S$$

$$P_1 = \frac{\pi (10)^2}{4} (60)$$

$$P_1 = 4712.4 \text{ N}$$

$$\frac{P_1}{A_1 R_1} = \frac{P_2}{A_2 R_2}$$

$$\frac{4712.4}{\frac{\pi}{4} (10)^2 (150)} = \frac{P_2}{\frac{\pi}{4} (20)^2 (100)}$$

$$P_2 = 12,566.4 \text{ N}$$

$$T = P_1 R_1 n_1 + P_2 R_2 n_2$$

$$T = P_1 R_1 n_1 + P_2 R_2 n_2$$

$$T = 4712.4 (0.15)(6) + 12,566.4 (0.10)(4)$$

$$T = 9267.6 \text{ N}\cdot\text{m}$$

PROBLEM 332.

A plate is fastened to a fixed member by four 20-mm diameter rivets arranged as shown. Compute the maximum and minimum shearing stress developed.

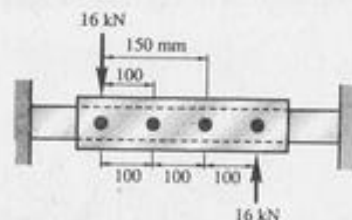

Solution:

$$S_S = \frac{Tr}{J}$$

$$J = A \Sigma (x^2 + y^2)$$

$$J = \frac{\pi}{4} (20)^2 [2(150)^2 + 2(50)^2]$$

$$J = 15,707,963 \text{ mm}^4$$

$$\text{max. } S_S = \frac{16(300)(150)(1000)}{15,707,963}$$

$$\text{max. } S_S = 45,837 \text{ MPa}$$

$$\text{min. } S_S = \frac{16(300)(50)(1000)}{15,707,963}$$

$$\text{min. } S_S = 15.27 \text{ MPa}$$

PROBLEM 333.

Six 20-mm diameter rivets fasten the plate in the figure to the fixed member. Determine the average shearing stress caused in each rivet by the 40-kN loads. What additional loads P can be applied before the average shearing stress in any rivet exceeds 60 MN/m^2 ?

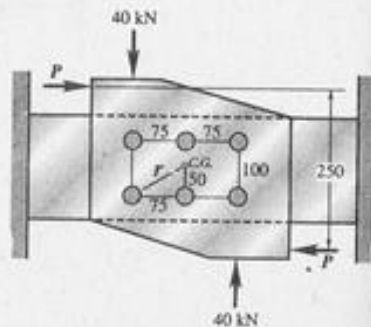

Solution:

$$a) S_S = \frac{Tr}{J}$$

$$T = (40)(150)(1000)$$

$$T = 6,000,000 \text{ N} \cdot \text{mm}$$

$$r = \sqrt{(50)^2 + (75)^2}$$

$$r = 90.14 \text{ mm}$$

$$J = A \sum (x^2 + y^2)$$

$$J = \frac{\pi}{4} (20)^2 [4(75)^2 + 6(50)^2]$$

$$J = 11,780,972 \text{ mm}^4$$

$$S_S = \frac{6,000,000 (90.14)}{11,780,972}$$

$$S_S = 45.91 \text{ MPa}$$

$$b) T = [250P - 150(40)] 1000 \text{ N} \cdot \text{mm}$$

$$S_S = \frac{Tr}{J}$$

$$60 = \frac{[250P - 6000] (1000) (90.4)}{11,780,972}$$

$$250P - 6000 = 7841.8$$

$$P = 55.37 \text{ kN}$$

PROBLEM 334.

The plate shown in the figure is fastened to the fixed member by three 10-mm-diameter rivets. Compute the value of the loads P so that the average shearing stress of any rivet does not exceed to MPa.

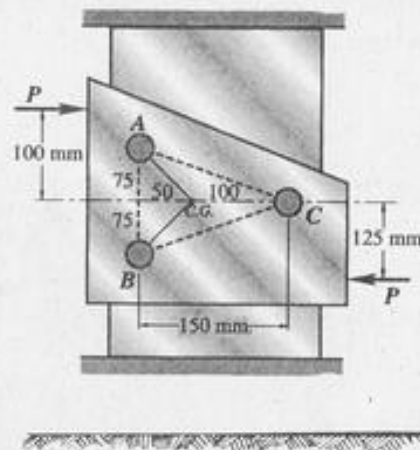

Solution:

The center of gravity of the rivet group is 100 mm from C.

$$OA = \sqrt{(50)^2 + (75)^2}$$

$$OA = 90.14 \text{ mm}$$

Therefore C is the most stressed rivet.

$$S_S = \frac{Tr}{J}$$

$$T = 225P \text{ N} \cdot \text{mm}$$

$$r = 100 \text{ mm}$$

$$J = A \sum (x^2 + y^2)$$

$$J = \frac{\pi}{4} (10)^2 [2(50)^2 + (100)^2 + 2(75)^2]$$

$$J = 2,061,670 \text{ mm}^4$$

$$70 = \frac{225P (100)}{2,061,670}$$

$$P = 6414 \text{ N}$$

PROBLEM 335.

A flanged bolt coupling consists of six 10-mm-diameter steel bolts evenly spaced around a bolt circle 300 mm in diameter, and four 20-mm-diameter aluminum bolts on a concentric bolt circle 200 mm in diameter. What torque can be applied without exceeding a shearing stress of 60 MN/m^2 in the steel or 40 MN/m^2 in the aluminum. Use $G_s = 83 \text{ GN/m}^2$ and $G_a = 28 \text{ GN/m}^2$.

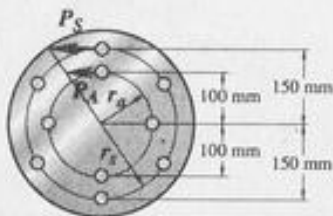

Solution:

$$\frac{S_s}{G_s R_s} = \frac{S_a}{G_a R_a}$$

$$\frac{S_s}{83(150)} = \frac{S_a}{28(100)}$$

$$S_s = 4.446 S_a$$

when $S_s = 60 \text{ MPa}$

$$60 = 4.446 S_a$$

$$S_a = 13.49 \text{ MPa} < 40 \text{ MPa (safe)}$$

$$P_s = \frac{\pi}{4} (10)^2 (60) = 4712 \text{ N}$$

$$P_a = \frac{\pi}{4} (20)^2 (13.49) = 4239 \text{ N}$$

$$T = P_s R_s n_s + P_a R_a n_a$$

$$T = 4712(0.15)(6) + 4239(0.10)(4)$$

$$T = 5937 \text{ N} \cdot \text{m}$$

TORSION OF THIN-WALLED TUBES; SHEAR FLOW

PROBLEM 338.

A tube 3 mm thick has the elliptical shape shown in the figure. What torque will cause a shearing stress of 60 MN/m^2 ?

Solution:

$$T = 2 A_t S_s$$

$$A = \pi ab$$

$$A = \pi \left(\frac{150}{2} \right) \left(\frac{75}{2} \right)$$

$$A = 8835.7 \text{ mm}^2$$

$$T = 2(8835.7)(0.003)(60)$$

$$T = 3181 \text{ N} \cdot \text{m}$$

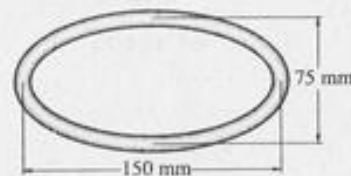

PROBLEM 339.

A tube 3 mm thick has the shape shown in the figure. Find the shearing stress caused by a torque of $700 \text{ N} \cdot \text{m}$ if dimension $a = 75 \text{ mm}$.

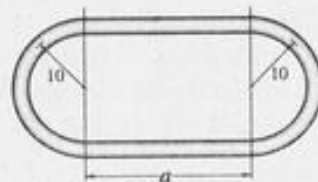

Solution:

$$S_s = \frac{T}{2 A_t}$$

$$A = \pi (10)^2 + 75(20)$$

$$A = 1814.2 \text{ mm}^2$$

$$S_s = \frac{700(1000)}{2(1814.2)(3)}$$

$$S_s = 64.30 \text{ MPa}$$

PROBLEM 340.

Find dimension a in Problem 339 if a torque of 600 N·m causes a shearing stress of 70 MN/m².

Solution:

$$S_s = \frac{T}{2 A_t}$$

$$A = \pi (10)^2 + 20a$$

$$70 = \frac{600(1000)}{2(100\pi + 20a)(3)}$$

$$a = 55.7 \text{ mm}$$

HELICAL SPRINGS**PROBLEM 343.**

Determine the maximum shearing stress and elongation in a helical steel spring composed of 20 turns of 20-mm-diameter wire on a mean radius of 80 mm when the spring is supporting a load of 2 kN. Use $G = 83 \text{ GN/m}^2$.

Solution:

$$S_s = \frac{16 PR}{\pi d^3} \left(\frac{4m-1}{4m-4} + \frac{0.615}{m} \right)$$

$$m = \frac{2R}{d}$$

$$m = \frac{2(80)}{20} = 8$$

$$S_s = \frac{16(2000)(80)}{\pi (20)^3} \left(\frac{4(8)-1}{4(8)-4} + \frac{0.615}{8} \right)$$

$$S_s = 120.60 \text{ MPa}$$

$$Y = \frac{64 PR^3 n}{G d^4}$$

$$Y = \frac{64(2000)(80)^3(20)}{(83 \times 10^3)(20)^4}$$

$$Y = 98.7 \text{ mm}$$

PROBLEM 345.

A helical spring is made by wrapping steel wire 20 mm in diameter around a forming cylinder 150 mm in diameter. Compute the number of turns required to permit an elongation of 100 mm without exceeding a shearing stress of 140 MPa. Use $G = 83 \text{ GPa}$.

Solution:

$$S_s = \frac{16 PR}{\pi d^3} \left(1 + \frac{d}{4R} \right)$$

$$R = 75 + 10 = 85 \text{ mm}$$

$$140 = \frac{16 P (65)}{\pi (20)^3} \left[1 + \frac{20}{4 (85)} \right]$$

$$P = 2443.5 \text{ N}$$

$$Y = \frac{64 P R^3 n}{G d^4}$$

$$100 = \frac{64(2443.5)(85)^3 n}{(83 \times 10^3)(20)^4}$$

$$n = 13.83 \text{ turns}$$

PROBLEM 349.

A load P is supported by two concentric steel springs arranged as shown. The inner spring consists of 30 turns of 75-mm-diameter wire on a mean diameter of 150 mm; the outer spring has 20 turns of 30-mm wire on a mean diameter of 200 mm. Compute the maximum load that will not exceed a shearing stress of 140 MPa in either spring.

Solution:

$$Y_1 = Y_2$$

$$\frac{64 P_1 R_1^3 n_1}{G d_1^4} = \frac{64 P_2 R_2^3 n_2}{G d_2^4}$$

$$\frac{P_1 (75)^3 (30)}{(20)^4} = \frac{P_2 (100)^3 (20)}{(30)^4}$$

$$P_2 = 3.2 P_1$$

$$S_s = \frac{16 P R}{\pi d^3} \left(1 + \frac{d}{4 R} \right)$$

$$140 = \frac{16 P (75)}{\pi (20)^3} \left[1 + \frac{20}{4 (75)} \right]$$

$$P_1 = 2749 \text{ N}$$

$$140 = \frac{16 P_2 (100)}{\pi (30)^3} \left[1 + \frac{30}{4 (100)} \right]$$

$$P_2 = 6904 \text{ N}$$

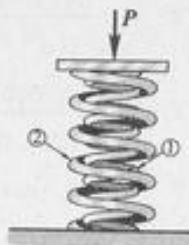

$$\text{If } P_1 = 2749 \text{ N}$$

$$P_2 = 3.2(2749)$$

$$P_2 = 8796.8 \text{ N} > 6904 \text{ N (fail)}$$

$$\text{If } P_2 = 6904$$

$$6904 = 3.2 P_1$$

$$P_1 = 2157.5 \text{ N} < 2749 \text{ N (safe)}$$

$$P = P_1 + P_2$$

$$P = 2157.5 + 6904$$

$$P = 9061.5 \text{ N}$$

PROBLEM 351.

A rigid plate of negligible mass rests on a central spring which is 20 mm higher than the symmetrically located outer springs. Each of the outer springs consists of 18 turns of 10-mm wire on a mean diameter of 100 mm. The central spring has 24 turns of 20-mm wire on a mean diameter of 150 mm. If a load $P = 5 \text{ kN}$ is now applied to the plate, determine the maximum shearing stress in each spring. Use $G = 83 \text{ GN/m}^2$.

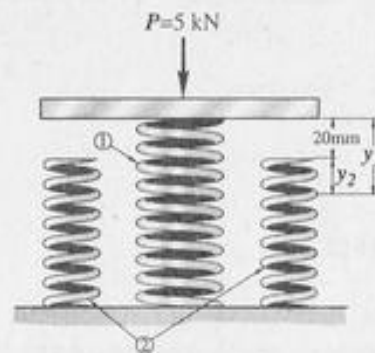

Solution:

$$Y_1 = Y_2 + 20$$

$$\frac{64P_1R_1^3n_1}{Gd_1^4} = \frac{64P_2R_2^3n_2}{Gd_2^4} + 20$$

$$\frac{64P_1(75)^3(24)}{(83 \times 10^3)(20)^4} = \frac{64P_2(50)^3(18)}{(83 \times 10^3)(10)^4} + 20$$

$$0.0488 P_1 = 0.1735 P_2 + 20$$

$$P_1 = 3.5552 P_2 + 409.8$$

$$P_1 + 2P_2 = 5000$$

$$(3.5552 P_2 + 409.8) + 2P_2 = 5000$$

$$P_2 = 826 \text{ N}$$

$$P_1 + 2(826) = 5000$$

$$P_1 = 3348 \text{ N}$$

$$S_s = \frac{16 PR}{\pi d^3} \left(1 + \frac{d}{4R} \right)$$

$$S_{S1} = \frac{16(3348)(75)}{\pi(20)^3} \left[1 + \frac{20}{4(75)} \right]$$

$$S_{S1} = 170.5 \text{ MPa}$$

$$S_{S2} = \frac{16(826)(50)}{\pi(10)^3} \left[1 + \frac{10}{4(50)} \right]$$

$$S_{S2} = 220.9 \text{ MPa}$$

PROBLEM 353.

A rigid bar, hinged at one end, is supported by two identical springs as shown. Each spring consists of 20 turns of 10-mm wire having a mean diameter of 150 mm. Compute the maximum shearing stress in the springs. Neglect the mass of the rigid bar.

Solution:

$$W = 10(9.81) = 98.1 \text{ N}$$

$$\Sigma M_A = 0$$

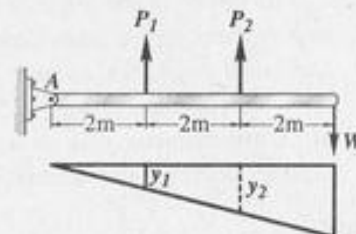
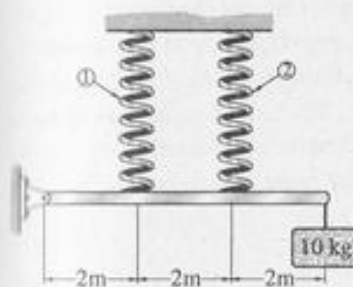

$$2P_1 + 4P_2 = 6(98.1)$$

$$P_1 + 2P_2 = 294.3$$

$$\frac{Y_1}{2} = \frac{Y_2}{4}$$

$$Y_2 = 2Y_1$$

$$\frac{64P_2R^3n}{Gd^4} = \frac{2(64)P_1R^3n}{Gd^4}$$

$$P_2 = 2P_1$$

$$P_1 + 2(2P_1) = 294.3$$

$$P_1 = 58.86 \text{ N}$$

$$P_2 = 2(58.86)$$

$$P_2 = 117.72 \text{ N}$$

$$S_s = \frac{16 PR}{\pi d^3} \left(1 + \frac{d}{4R} \right)$$

$$\text{max. } S_s = \frac{16(117.72)(75)}{\pi(10)^3} \left[1 + \frac{10}{4(75)} \right]$$

$$\text{max. } S_s = 46.46 \text{ MPa}$$

PROBLEM 355.

As shown in the figure, a homogenous 50-kg rigid block is suspended by three springs whose lower ends were originally at the same level. Each steel spring has 24 turns of 10-mm-diameter wire on a mean diameter of 100 mm, and $G = 83 \text{ GN/m}^2$. The bronze spring has 48 turns of 20-mm-diameter wire on a mean diameter of 150 mm, and $G = 42 \text{ GN/m}^2$. Compute the maximum shearing stress in each spring.

Solution:

$$Y = \frac{64 PR^3 n}{G d^4}$$

$$Y_1 = \frac{64 P_1 (50)^3 (24)}{(83 \times 10^3)(10)^4}$$

$$Y_1 = 0.23133 P_1$$

$$Y_2 = \frac{64 P_2 (50)^3 (24)}{(83 \times 10^3)(10)^4}$$

$$Y_2 = 0.23133 P_2$$

$$Y_3 = \frac{64 P_3 (75)^3 (48)}{(42 \times 10^3)(20)^4}$$

$$Y_3 = 0.19286 P_3$$

$$\frac{Y_3 - Y_1}{3} = \frac{Y_2 - Y_1}{1}$$

$$Y_3 - Y_1 = 3(Y_2 - Y_1)$$

$$Y_3 - Y_1 = 3Y_2 - 3Y_1$$

$$Y_3 = 3Y_2 - 2Y_1$$

$$0.19286 P_3 = 3(0.23133 P_2) - 2(0.23133 P_1)$$

$$P_3 = 3.6 P_2 - 2.4 P_1$$

$$\Sigma V = 0$$

$$P_1 + P_2 + P_3 = 50(9.81)$$

$$P_1 + P_2 + (3.6 P_2 - 2.4 P_1) = 490.5$$

$$4.6 P_2 - 1.4 P_1 = 490.5$$

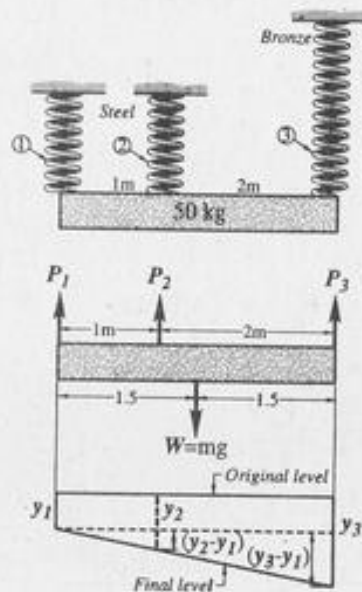

$$\Sigma M_3 = 0$$

$$3P_1 + 2P_2 = 50(9.81)(1.5)$$

$$3P_1 + 2P_2 = 735.75$$

$$P_2 = 367.9 - 1.5 P_1$$

$$4.6(367.9 - 1.5 P_1) - 1.4 P_1 = 490.5$$

$$1692.2 - 6.9 P_1 - 1.4 P_1 = 490.5$$

$$P_1 = 144.8 \text{ N}$$

$$P_2 = 367.9 - 1.5(144.8)$$

$$P_2 = 150.7 \text{ N}$$

$$P_2 = 150.7 \text{ N}$$

$$P_3 = 3.6(150.7) - 2.4(144.8)$$

$$P_3 = 195 \text{ N}$$

$$S_s = \frac{16 PR}{\pi d^3} \left(1 + \frac{d}{4R} \right)$$

$$S_{S1} = \frac{16(144.8)(50)}{\pi(10)^3} \left[1 + \frac{10}{4(50)} \right]$$

$$S_{S1} = 38.72 \text{ MPa}$$

$$S_{S2} = \frac{16(150.7)(50)}{\pi(10)^3} \left[1 + \frac{10}{4(50)} \right]$$

$$S_{S2} = 40.29 \text{ MPa}$$

$$S_{S3} = \frac{16(195)(75)}{\pi(20)^3} \left[1 + \frac{20}{4(75)} \right]$$

$$S_{S3} = 9.93 \text{ MPa}$$

Shear and Moment in Beams

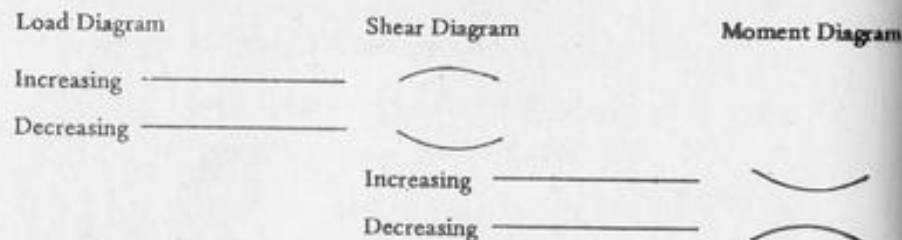

Write shear and moment equations for the beams in the following problems. Also draw shear and moment diagrams, specifying values at all change of loading positions and at all points of zero shear. Neglect the mass of the beam in each problem.

PROBLEM: 403

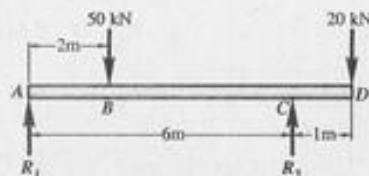
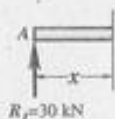

SOLUTIONS:

$$\sum M_A = 0$$

$$6 R_2 = 50(2) + 20(7)$$

$$R_2 = 40 \text{ kN}$$

$$R_1 = 50 + 20 - 40$$

$$R_1 = 30 \text{ kN}$$

$$V_{AB} = 30 \text{ kN}$$

$$M_{AB} = 30x \text{ KN}\cdot\text{m}$$

$$V_{BC} = 30 - 50 = -20 \text{ kN}$$

$$M_{BC} = 30x - 50(x-2)$$

$$M_{BC} = 100 - 20x \text{ KN}\cdot\text{m}$$

$$V_{CD} = 30 - 50 + 40 = 20 \text{ kN}$$

$$M_{CD} = -20(7-x) = 20x - 140 \text{ KN}\cdot\text{m}$$

or

$$\sum M_C:$$

$$M_{CD} = 30(x) - 50(x-2) + 40(x-6)$$

$$= 30x - 50x + 100 + 40x - 240$$

$$M_{CD} = 20x - 140 \text{ KN}\cdot\text{m}$$

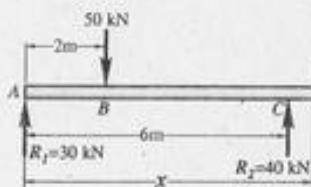
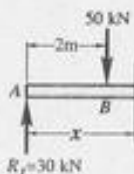
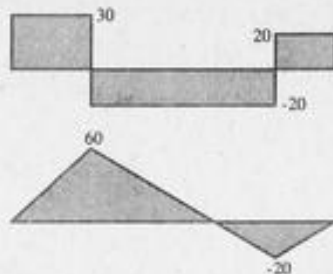

PROBLEM: 404

$$\sum M_D = 0$$

$$6 R_1 + 40 = 10(7)$$

$$R_1 = 6 \text{ kN}$$

$$R_2 = 10 - 6$$

$$R_2 = 4 \text{ kN}$$

$$V_{AB} = 10 \text{ kN}$$

$$M_{AB} = 10x \text{ KN}\cdot\text{m}$$

$$V_{BC} = -10 + 6 = -4 \text{ kN}$$

$$M_{BC} = 6(x-2) - 10x$$

$$M_{BC} = (-4x - 12) \text{ KN}\cdot\text{m}$$

$$V_{CD} = -10 + 6 = -4 \text{ kN}$$

$$M_{CD} = 6(x-2) + 40 - 10x$$

$$M_{CD} = (-4x + 29) \text{ KN}\cdot\text{m}$$

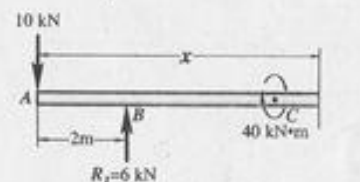
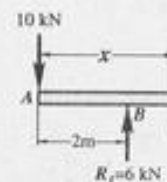
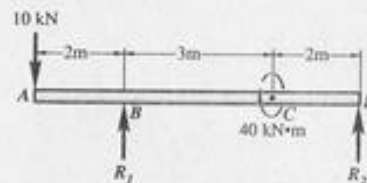
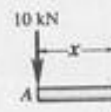

PROBLEM: 405

$$\sum M_A = 0$$

$$16 R_2 = 30(2) + 10(10)(5)$$

$$R_2 = 56 \text{ kN}$$

$$R_1 = 30 + 10(10) - 56$$

$$R_1 = 74 \text{ kN}$$

$$V_{AB} = 74 - 10x \text{ kN}$$

$$M_{AB} = 74x - 10(x)\left(\frac{x}{2}\right) \text{ KN}\cdot\text{m}$$

$$V_{BC} = 74 - 30 - 10x$$

$$V_{BC} = 44 - 10x$$

$$M_{BC} = 74x - 30(x-2) - 10x\left(\frac{x}{2}\right)$$

$$M_{BC} = (-5x^2 + 44x + 60) \text{ KN}\cdot\text{m}$$

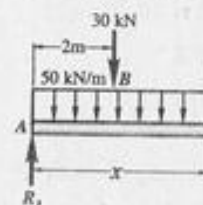
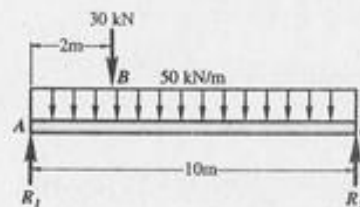

PROBLEM: 407

$$\sum M_A = 0$$

$$5R_2 = 30(2)(3)$$

$$R_2 = 36 \text{ KN}$$

$$R_1 = 30(2) - 36$$

$$R_1 = 24 \text{ KN}$$

$$V_{AB} = 24$$

$$M_{AB} = 24X$$

$$V_{BC} = 24 - 30(x - 2)$$

$$V_{BC} = 84 - 30X$$

$$M_{BC} = 24X - 30(X - 2)\left(\frac{X - 2}{2}\right)$$

$$V_{CD} = -36$$

$$M_{CD} = 36(5 - X)$$

$$X = \frac{24}{30} = 0.8$$

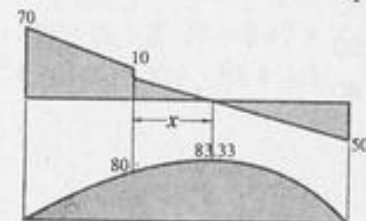
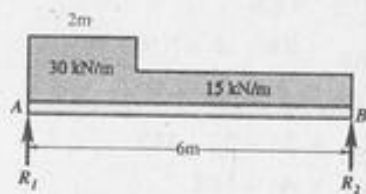
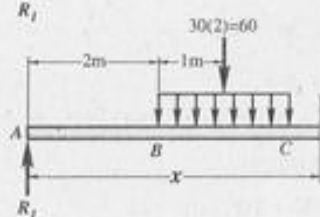
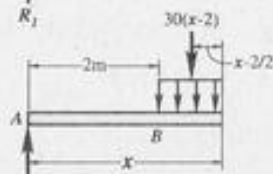
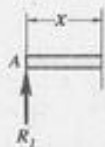
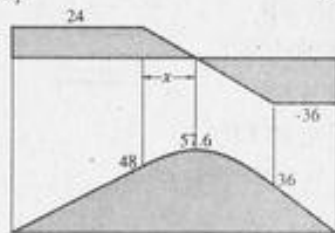
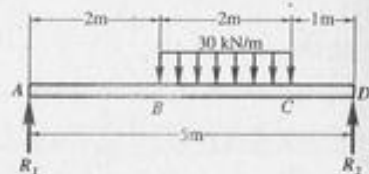

PROBLEM: 408

$$\sum M_A = 0$$

$$6R_2 = 30(2)(1) + 15(4)(4)$$

$$R_2 = 50 \text{ KN}$$

$$R_1 = 30(2) + 15(4) - 50$$

$$R_1 = 70 \text{ KN}$$

$$V_{AB} = 70 - 30X$$

$$M_{AB} = 70X - 30X\left(\frac{X}{2}\right)$$

$$V_{BC} = 70 - 60 - 15(X - 2)$$

$$V_{BC} = 40 - 15X$$

$$M_{BC} = 70X - 60(X - 1)$$

$$X = \frac{10}{15} = 0.667 \text{ m}$$

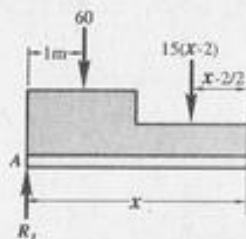
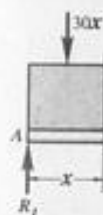

PROBLEM 411:

$$R = \frac{1}{2} WL$$

$$M = \left(\frac{WL}{2}\right) \times \frac{2}{3} L$$

$$M = \frac{WL^2}{3}$$

$$\frac{y}{L - X} = \frac{W}{L}$$

$$y = \frac{W}{L} (L - X)$$

$$\frac{Z}{X} = \frac{W}{L}$$

$$Z = \frac{W}{L} X$$

$$V = -\frac{1}{2} XZ - XY$$

$$V = -\frac{1}{2} X \left(\frac{W}{L} X\right) - X \left(\frac{W}{L}\right) (L - X)$$

$$V = -\frac{WX^2}{2L} - \frac{WX}{L} (L - X)$$

$$M = -\frac{1}{2} XZ \left(\frac{2}{3} X\right) - XY \left(\frac{X}{2}\right)$$

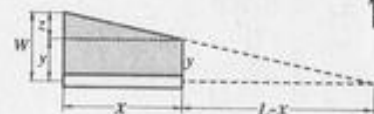
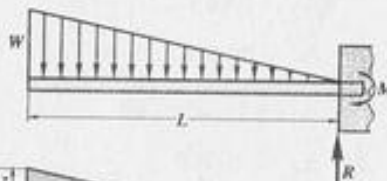

$$M = \frac{-X^2}{3} \left(\frac{WX}{L}\right) - \frac{X^2}{2} \left(\frac{W}{L}\right)(L-X)$$

$$M = \frac{WX^3}{3L} - \frac{WX^2}{2L}(L-X)$$

$$M = -\frac{WX^3}{3L} - \frac{WX^2}{2} + \frac{WX^3}{2L}$$

$$M = \frac{WX^3}{6L} - \frac{WX^2}{2}$$

PROBLEM 412:

$$\Sigma M_A = 0$$

$$6R_2 = 10(6)(5)$$

$$R_2 = 50 \text{ KN}$$

$$R_1 = 6(10) - 50$$

$$R_1 = 10 \text{ KN}$$

$$V_{AB} = 10$$

$$M_{AB} = 10X$$

$$V_{BC} = 10 - 10(X-2)$$

$$M_{BC} = 10X - 10(X-2)\left(\frac{X-2}{2}\right)$$

$$M_{BC} = 10X - 5(X-2)^2$$

$$V_{CD} = 10(8-X)$$

$$M_{CD} = 10(8-X)\left(\frac{8-X}{2}\right)$$

$$M_{CD} = -5(8-x)^2$$

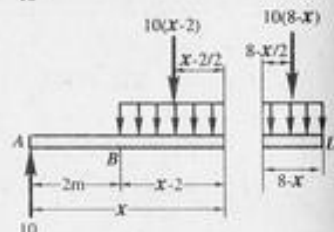
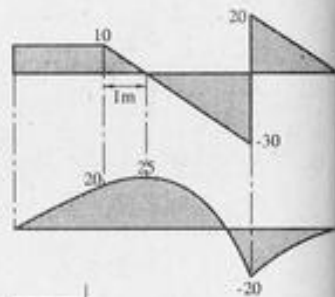
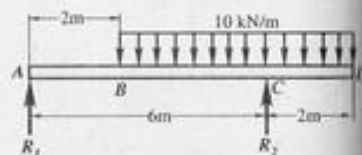

PROBLEM 415:

$$R = 8(5) - 20$$

$$R = 20 \text{ KN}$$

$$M = 8(5)(2.5) - 20(3)$$

$$M = 40 \text{ KN}\cdot\text{m}$$

$$V_{AB} = -8X$$

$$M_{AB} = -8X\left(\frac{X}{2}\right)$$

$$V_{BC} = 20 - 8X$$

$$M_{BC} = 20(X-2) - 8X\left(\frac{X}{2}\right)$$

$$M_{BC} = 20X - 40 - 4X^2$$

$$M_{BC} = (-4X^2 + 20X - 40) \text{ KN}\cdot\text{m}$$

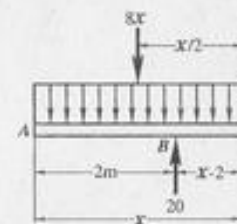
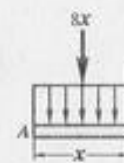
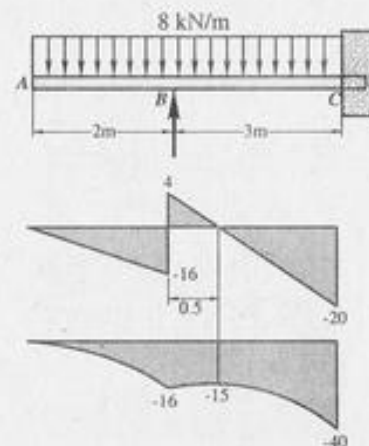

PROBLEM 416:

$$\Sigma M_A = 0$$

$$R_2(L) = \frac{WL}{2} \left(\frac{2}{3}L\right)$$

$$R_2 = \frac{WL}{3}$$

$$R_1 = \frac{WL}{2} - \frac{WL}{3}$$

$$R_1 = \frac{WL}{6}$$

$$\frac{y}{X} = \frac{W}{L}$$

$$y = \frac{WX}{L}$$

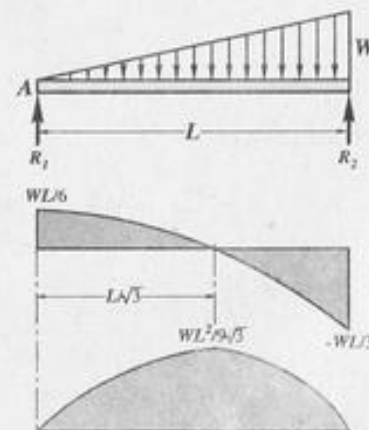

$$V = R_1 - \frac{1}{2} xy$$

$$V = \frac{WL}{6} - \frac{1}{2} X \left(\frac{WX}{L} \right)$$

$$V = \frac{WL}{6} - \frac{WX^2}{2L}$$

$$M = R_1 X - \frac{1}{2} xy \left(\frac{X}{3} \right)$$

$$M = \frac{WLX}{6} - \frac{1}{6} X^2 \left(\frac{WX}{L} \right)$$

$$M = \frac{WLX}{6} - \frac{WX^3}{6L}$$

for max. M , $V = 0$

$$0 = \frac{WL}{6} - \frac{WX^2}{2L}$$

$$0 = \frac{L}{3} - \frac{X^2}{L}$$

$$X = \frac{L}{\sqrt{3}}$$

$$M = \frac{WL}{6} \left(\frac{L}{\sqrt{3}} \right) - \frac{W}{6L} \left(\frac{L}{\sqrt{3}} \right)^3$$

$$M = \frac{WL^2}{6\sqrt{3}} - \frac{WL^2}{18\sqrt{3}}$$

$$M = \frac{WL^2}{9\sqrt{3}}$$

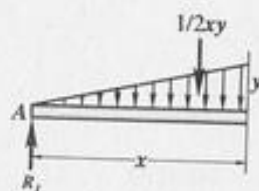

PROBLEM 417:

$$R_1 = R_2 = \frac{1}{2} (W) \left(\frac{L}{2} \right) = \frac{WL}{4}$$

$$\frac{y}{x} = \frac{W}{\frac{L}{2}}$$

$$y = \frac{2WX}{L}$$

$$V = R_1 - \frac{1}{2} Xy$$

$$V = \frac{WL}{4} - \frac{1}{2} X \left(\frac{2WX}{L} \right)$$

$$V = \frac{WL}{4} - \frac{WX^2}{L}$$

$$M = R_1 X - \frac{1}{2} Xy \left(\frac{X}{3} \right)$$

$$M = \frac{WLX}{4} - \frac{1}{6} X^2 \left(\frac{2WX}{L} \right)$$

$$M = \frac{WLX}{4} - \frac{WX^3}{3L}$$

max. M is at $X = \frac{L}{2}$

$$M = \frac{WL}{4} \left(\frac{L}{2} \right) - \frac{W}{3L} \left(\frac{L}{2} \right)^3$$

$$M = \frac{WL^2}{8} - \frac{WL^2}{24}$$

$$M = \frac{WL^2}{12}$$

PROBLEM 419:

$$\sum M_A = 0$$

$$5R_2 = \frac{1}{2} (3)(20)(2)$$

$$R_2 = 12 \text{ KN}$$

$$R_1 = \frac{1}{2} (3)(20) - 12$$

$$R_1 = 18 \text{ KN}$$

$$y = \frac{20}{3}$$

$$x = \frac{3}{3}$$

$$y = \frac{20X}{3}$$

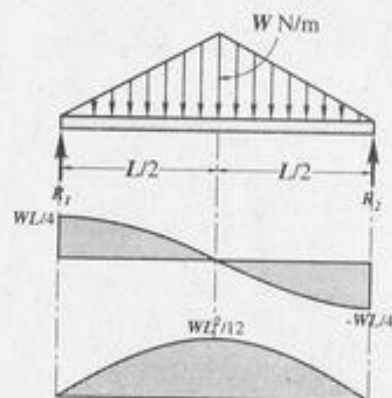

$$V_{AB} = 18 - \frac{1}{2}xy$$

$$V_{AB} = 18 - \frac{1}{2}x\left(\frac{20x}{3}\right)$$

$$V_{AB} = 18 - \frac{10x^2}{3}$$

$$M_{AB} = 18x - \frac{1}{2}x\left(\frac{20x}{3}\right)\left(\frac{x}{3}\right)$$

$$M_{AB} = 18x - \frac{10x^2}{9}$$

$$V_{BC} = -12$$

$$M_{BC} = 12(5-x)$$

max, M occurs at $V = 0$

$$18 - \frac{10x^2}{3} = 0$$

$$10x^2 = 54$$

$$x = 2.324 \text{ m}$$

$$\text{max, } M = 18(2.324) - \frac{10(2.324)^3}{9}$$

$$\text{max, } M = 27.885 \text{ KN}\cdot\text{m}$$

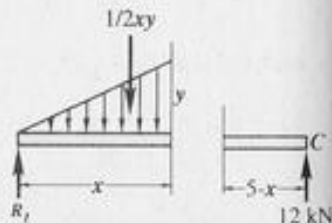
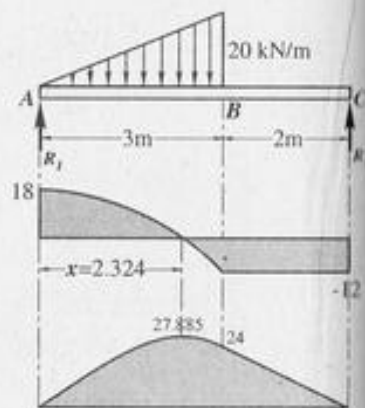

PROBLEM:

421. Write the shear and moment equations for the built-in circular shown. If (a) the load P is vertical as shown, (b) if the load P is horizontal to the left.

Soln.

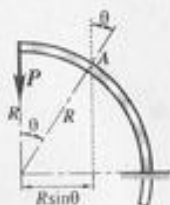

$$M_A = -PR \sin \theta$$

$$V_A = -P \cos \theta$$

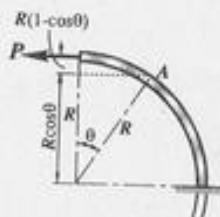

$$M_A = -PR(1 - \cos \theta)$$

$$V_A = -P \sin \theta$$

PROBLEM 422;

$$V_{AB} = \frac{P}{2} \sin \theta$$

$$M_{AB} = \frac{P}{2} R(1 - \cos \theta)$$

$$V_{BC} = -\frac{P}{2} \sin (180 - \theta)$$

$$V_{BC} = \frac{P}{2} \sin \theta$$

$$M_{BC} = \frac{P}{2} R + R \cos (180 - \theta) - PR \cos (180 - \theta)$$

$$M_{BC} = \frac{P}{2} R - R \cos \theta + PR \cos \theta$$

$$M_{BC} = \frac{PR}{2} - \frac{PR}{2} \cos \theta + PR \cos \theta$$

$$M_{BC} = \frac{PR}{2} (1 + \cos \theta)$$

or considering the right segment

$$M_{BC} = \frac{P}{2} (R - R \cos (180 - \theta))$$

$$M_{BC} = \frac{PR}{2} (1 - \cos (180 - \theta))$$

$$M_{BC} = \frac{PR}{2} (1 + \cos \theta)$$

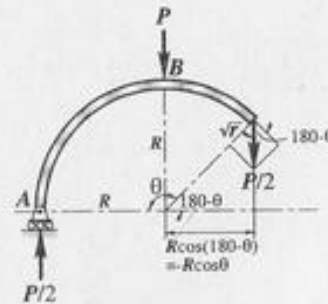
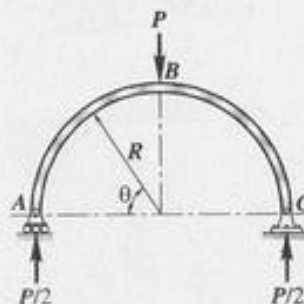
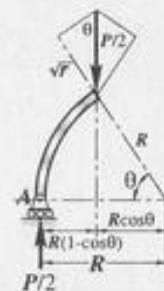

PROBLEM 427:

$$\Sigma M_B = 0$$

$$5R_2 + 10(1) = 10(2)(2)$$

$$R_2 = 6 \text{ KN}$$

$$R_1 = 10 + 2(10) - 6$$

$$R_1 = 24 \text{ KN}$$

$$X = \frac{14}{10} = 1.4 \text{ m.}$$

$$M_B = -10(1) = -10 \text{ KN}\cdot\text{m}$$

$$M_C = -10 + 14(1) = 4 \text{ KN}\cdot\text{m}$$

$$M_F = 4 + \frac{1}{2}(14)(1.4) = 13.8 \text{ KN}\cdot\text{m}$$

$$M_D = 13.8 - \frac{1}{2}(6)(0.60) = 12 \text{ KN}\cdot\text{m}$$

$$M_E = 12 - (6)(2) = 0$$

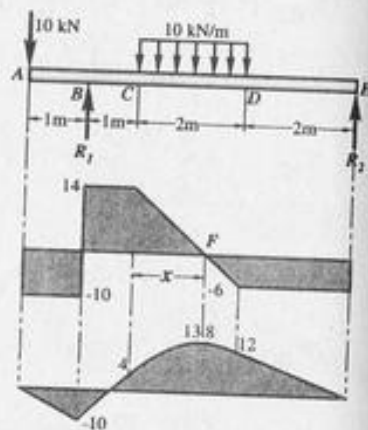

PROBLEM 428

$$\Sigma M_A = 0$$

$$4R_2 = 60(1) + 30(6) + 5(4)(2)$$

$$R_2 = 70 \text{ KN}$$

$$R_1 = 60 + 30 + 5(4) - 70$$

$$R_1 = 40 \text{ KN}$$

$$M_B = \frac{1}{2}(40 + 35) = 37.5 \text{ KN}\cdot\text{m}$$

$$M_C = 37.5 - \frac{1}{2}(25 + 40)(3)$$

$$M_C = -60 \text{ KN}\cdot\text{m}$$

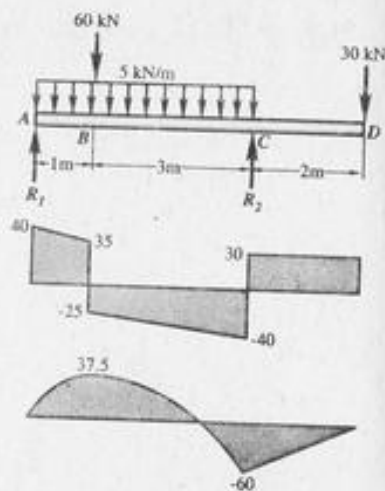

PROBLEM 430. In the overhanging beam shown, determine P so that the moment over each support equals the moment at mid span.

Sol'n.

$$R_1 = P + 5(4) = P + 20$$

$$M_B = M_E$$

$$M_B = P(1) + 5(1)(0.5) = P + 2.5$$

$$M_E = (P + 20)(3) - P(4) - 5(4)(2)$$

$$M_E = 3P + 60 - 4P - 40$$

$$M_E = 20 - P$$

$$P + 2.5 = 20 - P$$

$$P = 8.75 \text{ KN}$$

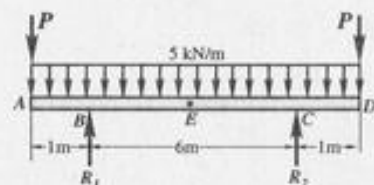

PROBLEM 433.

$$\Sigma M_A = 0$$

$$5R_2 + 200 = 50(7)$$

$$R_2 = 30 \text{ KN}$$

$$R_1 = 50 - 30 = 20 \text{ KN}$$

$$M_B = 20(2) = 40 \text{ KN}\cdot\text{m}$$

$$M_B = 40 - 200 = -160 \text{ KN}\cdot\text{m}$$

$$M_C = 160 + 20(3) = -100 \text{ KN}\cdot\text{m}$$

$$M_O = -100 + 50(2) = 0$$

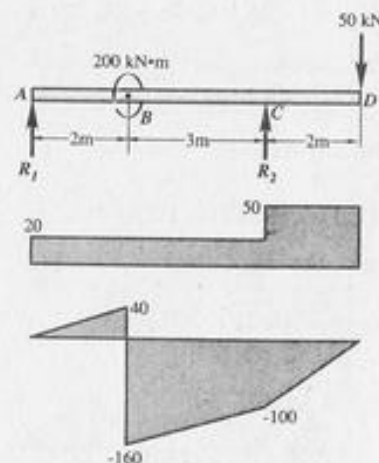

PROBLEM 434.

$$\Sigma M_B = 0$$

$$5R_2 + 30(1) = 20(3)(1.5) + 60$$

$$R_2 = 24 \text{ KN}$$

$$R_1 = 30 + 20(3) - 24$$

$$R_1 = 66 \text{ KN}$$

$$X = \frac{36}{20} = 1.8 \text{ m}$$

$$M_B = -30(1) = -30 \text{ KN}\cdot\text{m}$$

$$M_F = -30 + \frac{1}{2}(36)(1.8)$$

$$M_F = 2.4 \text{ KN}\cdot\text{m}$$

$$M_C = 2.4 - \frac{1}{2}(24)(1.2)$$

$$M_C = -12 \text{ KN}\cdot\text{m}$$

$$M_D = -12 - 24(1) = -36 \text{ KN}\cdot\text{m}$$

$$M_D = -36 + 60 = +24 \text{ KN}\cdot\text{m}$$

$$M_E = 24 - 24(1) = 0$$

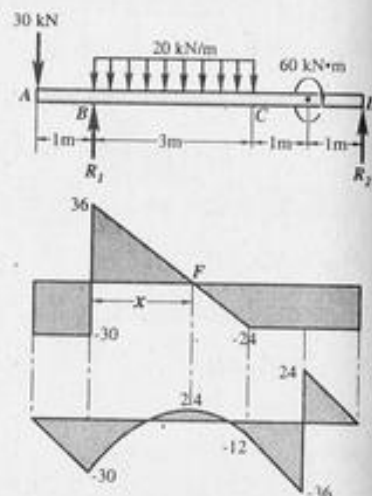

PROBLEM 436.

$$R = 10 + 20(2) - 10(2)$$

$$R = 30 \text{ KN}$$

$$M_E = -10(3) - 20(2)(1) + 10(2)(5)$$

$$M_E = 30 \text{ KN}\cdot\text{m}$$

$$X = \frac{10}{20} = 0.5 \text{ m}$$

$$M_B = 20 \text{ KN}\cdot\text{m}$$

$$M_C = 20 + 20(1) = 40 \text{ KN}\cdot\text{m}$$

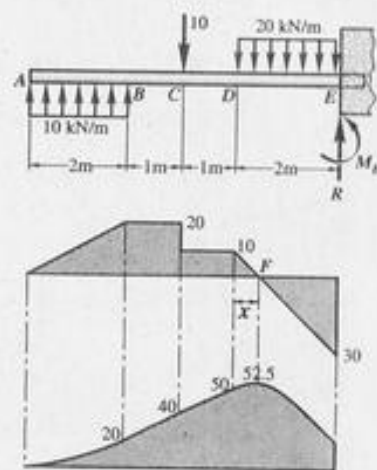

$$M_D = 40 - 10(1) = 30 \text{ KN}\cdot\text{m}$$

$$M_F = 30 + \frac{1}{2}(10)(0.5) = 32.5 \text{ KN}\cdot\text{m}$$

$$M_E = 32.5 - \frac{1}{2}(30)(1.5) = 15 \text{ KN}\cdot\text{m}$$

$$M_E = 15 - 15 = 0$$

PROBLEM 439. A beam supported on three reactions as shown consists of two segments joined at a frictionless hinge at which the bending moment is zero.

Sol'n.

$$\Sigma M_H = 0$$

$$6R_3 = 20(4)(3)$$

$$R_3 = 48 \text{ KN}$$

$$R = 20(4) - 48$$

$$R = 32 \text{ KN}$$

$$\Sigma M_A = 0$$

$$4R_2 = 20(2)(1) + 40(2) + 32(5)$$

$$R_2 = 70 \text{ KN}$$

$$R_1 = 20(2) + 40 + 32 - 70$$

$$R_1 = 42 \text{ KN}$$

$$X = \frac{32}{20} = 1.6 \text{ m}$$

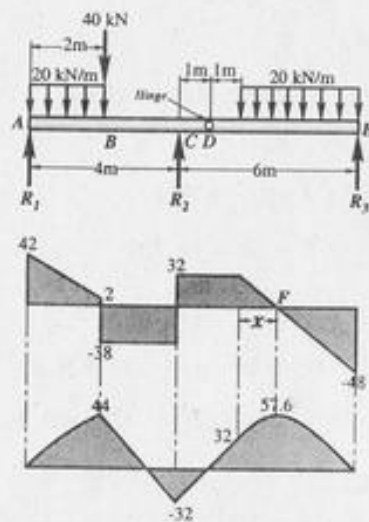

$$M_B = \frac{2}{2}(42 + 2) = 44 \text{ KN}\cdot\text{m}$$

$$M_C = 44 - 38(2) = -32 \text{ KN}\cdot\text{m}$$

$$M_H = -32 + 32(1) = 0 \text{ (check)}$$

$$M_D = 0 + 32(1) = 32 \text{ KN}\cdot\text{m}$$

$$M_F = 32 + \frac{1}{2}(1.6)(32)$$

$$M_F = 57.6 \text{ KN}\cdot\text{m}$$

$$M_E = 57.6 - \frac{1}{2}(48)(2.4)$$

$$M_E = 0$$

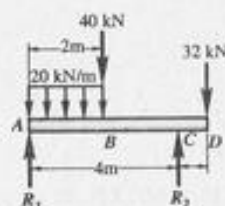
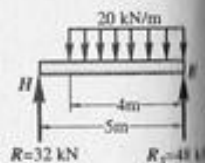

PROBLEM 441. A beam ABCD is supported by a hinge at A and a roller at D. It is subjected to the loads shown which act at the ends of the vertical members BE and CF. These vertical members are rigidly attached to the beam at B and C. Draw shear & moment diagram for beam ABCD only.

Sol'n.

$$\sum M_A = 0$$

$$D_V(7) + 4(2) + 3(2) = 14(2)$$

$$D_V = 2 \text{ KN}$$

$$A_V = 4 + 2 = 6 \text{ KN}$$

$$A_H = 3 + 14 = 17 \text{ KN}$$

$$M_B = -6(2) = -12 \text{ KN}\cdot\text{m}$$

$$M_{B^1} = -12 - 6 = -18 \text{ KN}\cdot\text{m}$$

$$M_C = -18 - 2(2) = -22 \text{ KN}\cdot\text{m}$$

$$M_{C^1} = -22 + 28 = 6 \text{ KN}\cdot\text{m}$$

$$M_D = 6 - 2(3) = 0$$

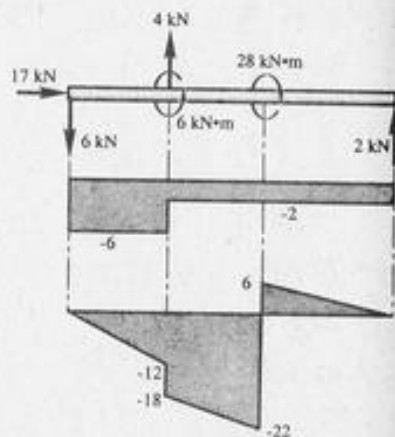
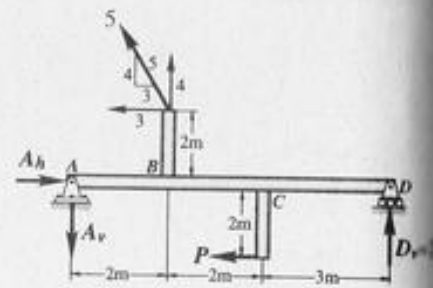

PROBLEM 442.

$$\sum MR_1 = 0$$

$$R_2 L = \frac{1}{2} WL \left(\frac{2}{3} L \right)$$

$$R_2 = \frac{WL}{3}$$

$$R_1 = \frac{WL}{2} - \frac{WL}{3}$$

$$R_1 = \frac{WL}{6}$$

$$y = \frac{WX}{L}$$

max, M is at $V = 0$

$$\frac{WL}{6} - \frac{1}{2} Xy = 0$$

$$\frac{WL}{6} - \frac{1}{2} X \left(\frac{WX}{L} \right) = 0$$

$$\frac{L}{3} - \frac{X^2}{L} = 0$$

$$X^2 = \frac{L^2}{3}$$

$$X = \frac{L}{\sqrt{3}}$$

