

10

Full marks: 72

Time: 3 Hours

- N.B:-**
- (i) Answer any **SIX** questions, taking **THREE** from each section.
 - (ii) Figures in the margin indicate full marks.
 - (iii) Use separate answer script for each section.
 - (iv) Assume reasonable value for any data missing.

SECTION-A

- Q.1(a)** Derive the relation between Radius of Curvature and Bending Moment. 3.00
- Q.2** Calculate the maximum value of $EI\delta$ for the beam loaded as shown in the figure below by Double Integration method. 9.00

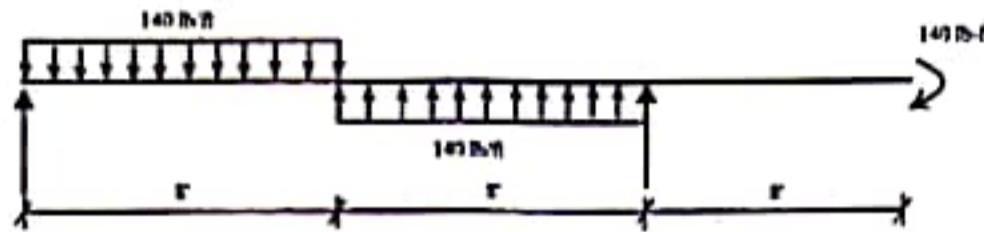

- Q.2** Using area moment method, calculate the value of maximum $EI\delta$ for the beam shown in figure below. EI is constant. 12.00

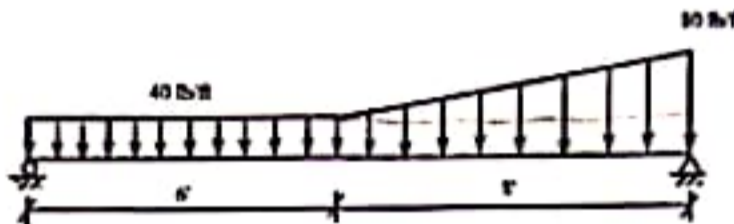

- Q.3(a)** What are the differences between actual beam and conjugate beam? Explain with figures. 3.00
- (b)** Using conjugate beam method find (i) Deflection of E (ii) Deflection of B and (iii) Slope of B and C. Given that $E = 30000$ ksi. 9.00

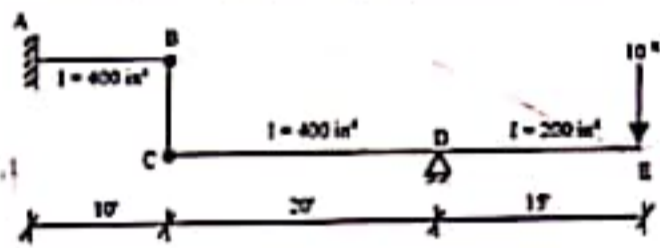

- Q.4(a)** Derive the critical load for Euler's Column for a (pin ended column.) 3.00
- (b)** A beam is supported by steel column as shown in figure below. Calculate the safe value of 'P' carries by the beam. $E = 30 \times 10^6$ psi. 9.00

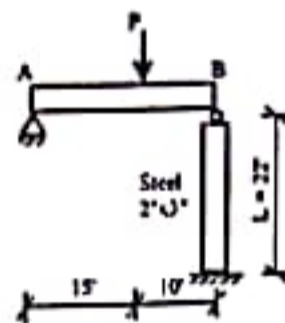

SECTION-B

- Q.5 (a)** Derive the torsion formula to determine stress in a circular shaft. 3.00
- (b)** The compound shaft is shown in figure below which is attached to rigid supports. For the bronze segment AB, the maximum shearing stress is limited to 8000 psi and for the steel segment BC it is limited to 12 ksi. Determine the diameters of each segment so that each material will be simultaneously stressed to its permissible limit when a torque $T = 20$ k-ft is applied. For bronze, $G = 6 \times 10^6$ psi and for steel $G = 12 \times 10^6$ psi. 9.00

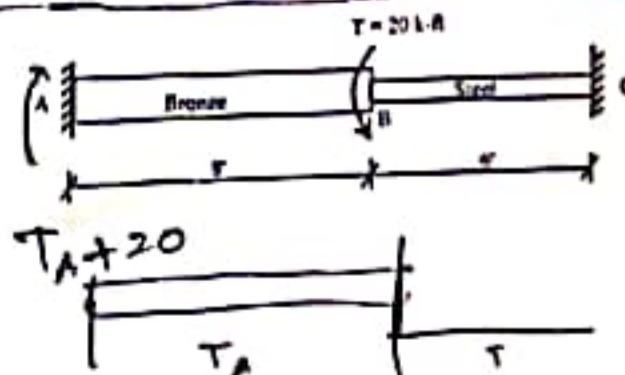

2/9

Q.6(a) Show that the kern of a rectangular section is a rectangle ^{al} whose diagonal one-third the arm lengths of the rectangle. 3.00

(b) A concrete dam has the profiles shown in figure below. If concrete weighs 125 lb/ft^3 and water weighs 62.5 lb/ft^3 , determine the maximum stress and draw stress distribution along the section X-X. 9.00

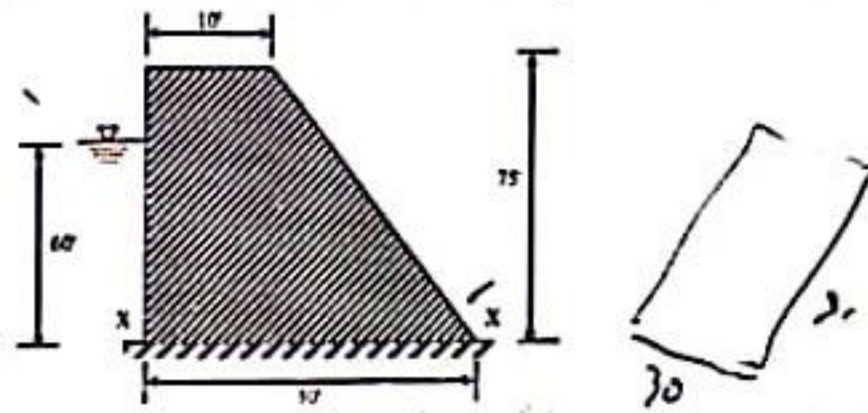

Q.7(a) A plane element is subjected to the state of stress shown in following figure. Using Mohr's circle, determine the principle stresses and draw the principle planes. 6.00

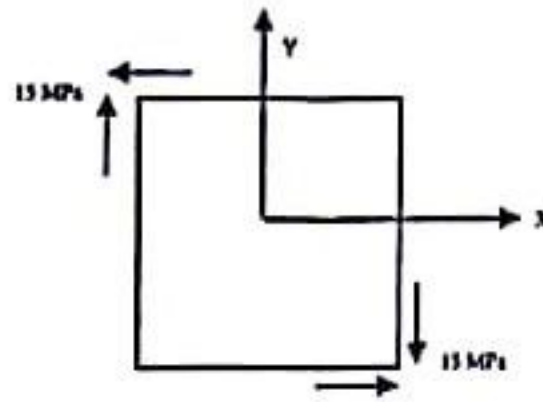

(b) A homogeneous 50 kg rigid block is suspended by the three springs whose lower ends were originally at the same level. Each steel spring has 24 turns of 10 mm diameter wire on a mean diameter of 100 mm, and $G = 83 \text{ GPa}$. The bronze spring has 48 turns of 20 mm diameter on a mean diameter of 150 mm and $G = 42 \text{ GPa}$. Compute the maximum shearing stress in each spring. 6.00

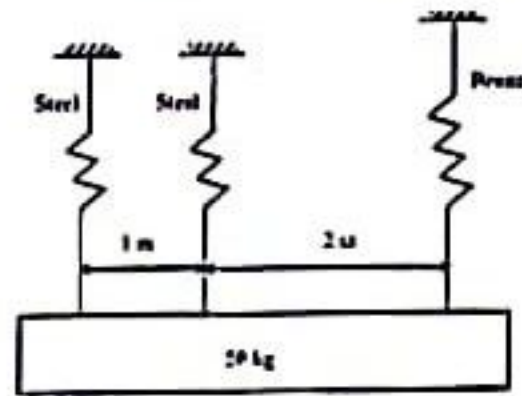

Q.8(a) Derive an illustration for combined axial and bending loads. 3.00

(b) Compute the principle stress and maximum shearing stress at point 'A' and 'B' of the beam shown in following figure. 9.00

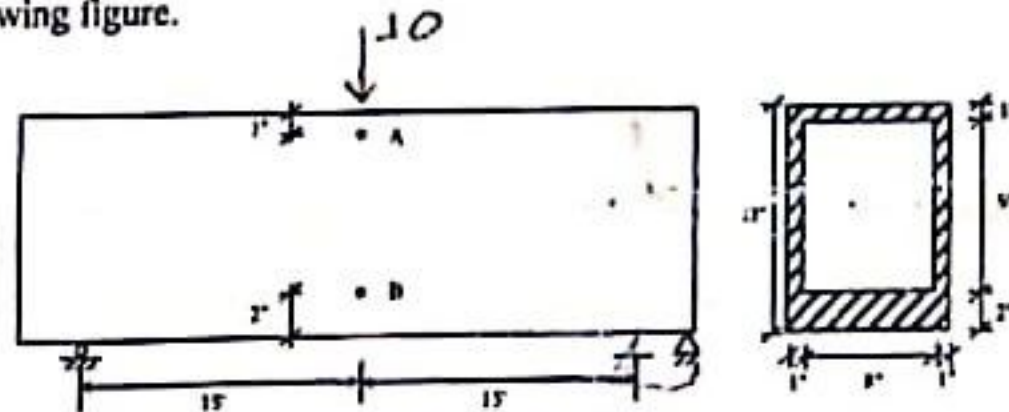

CE 2213
 Mechanics of Materials-II

Time: 3 Hours

Full Marks: 72

- N.B.:-
- (i) Answer any SIX questions, taking THREE from each section.
 - (ii) Figure in the margin indicate full marks.
 - (iii) Use separate answer script for each section.
 - (iv) Assume reasonable value for any data missing.

SECTION-A

Q.1 Determine the position of maximum deflection and compute the value of EIY at the same location of the beam loaded as shown in figure below (use double integration method). 12.00

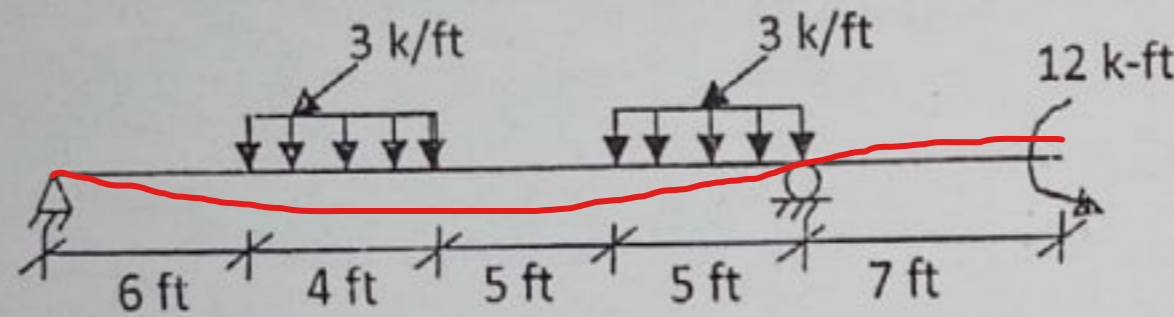

- Q.2 (a) State the theorems of semigraphical technique for findings slope and deflection of a beam. 3.00
 (b) Using area-moment method, calculate the value of maximum ' $EI\delta$ ' for the beam shown in figure below. 9.00
 EI is constant.

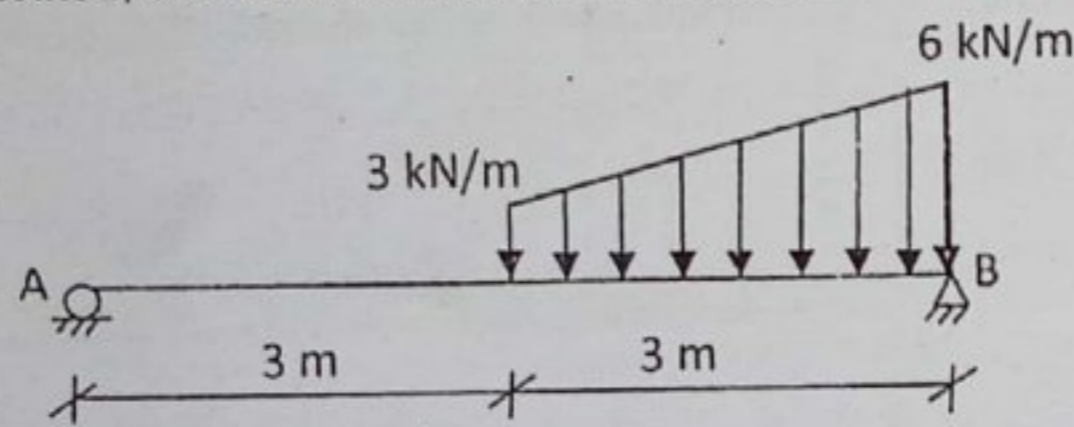

class lecture

- Q.3 (a) Write the propositions of conjugate beam. 4.00
 (b) Using conjugate beam method, calculate (i) M_A and M_B & (ii) Deflection at 'B' (Given, $E = 30000 \text{ k/in}^2$ & $I = 200 \text{ in}^4$). 8.00

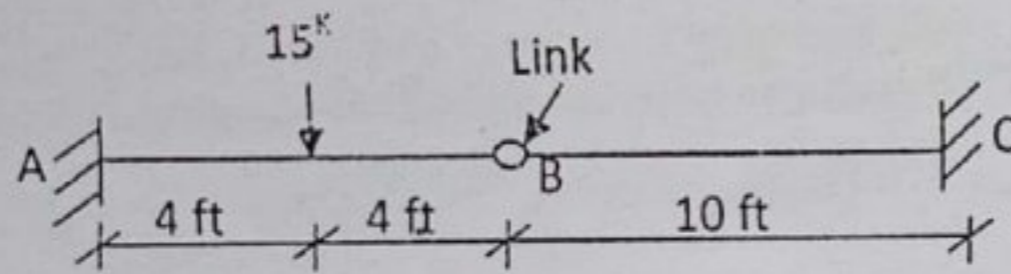

class lecture

- Q.4 (a) Derive the theoretical analysis of the critical load for a long column. 4.00
 (b) An aluminum strut 6 ft long has a rectangular section $1/4" \times 2"$. A bolt through each end secures the strut so that it acts as a hinged column about an axis perpendicular to the 2-inch dimension, and as a fixed-ended column about an axis perpendicular to the $1/4$ inch dimension. Determine the safe control load, using a factor of safety of 2 and $E = 10.3 \times 10^6 \text{ psi}$. 8.00

SECTION-B

- Q.5 (a) Derive the illustration for the shearing stress in solid circular shaft of diameter 'd'. 4.00
 (b) Determine the maximum shearing stress in a 4 inch diameter solid circular shaft carrying a torque of 228000 lb-in. What is the angle of twist per unit length if the material is steel for which $G = 12 \times 10^6 \text{ psi}$? 8.00
- Q.6 (a) Derive an expression for the elongation of a close-coiled helical spring neglecting the effect of direct shearing deformation. 4.00
 (b) A homogeneous 50 kg rigid block is suspended by the three springs whose lower ends were originally at the same level. Each steel spring has 24 turns of 10 mm diameter wire on a mean diameter of 100 mm, and $G = 83 \text{ GPa}$. The bronze spring has 48 turns of 20 mm diameter wire on a mean diameter of 150 mm and $G = 42 \text{ GPa}$. Compute the maximum shearing stress in each spring. 8.00

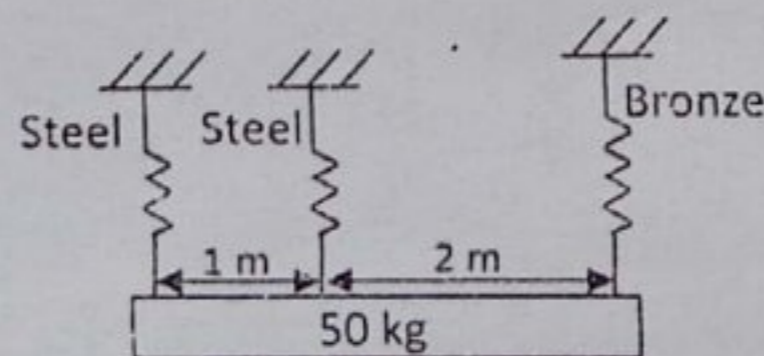

- Q.7 (a) What is the significance of Kern of a section? Show that the Kern of a circular section is a circle whose diameter is one-quarter the diameter of the section. 3.00
 (b) A rectangular pier is subjected to a compressive load of 130 Kips as shown in figure. Find the stress intensities on all the four corners of the pier. 6.00

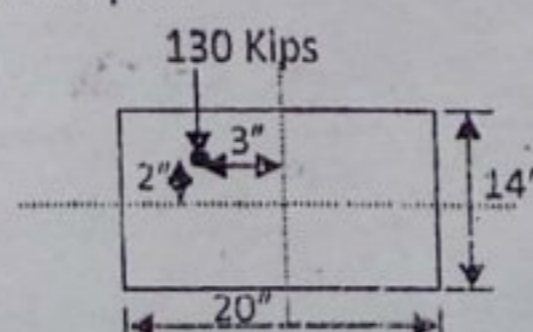

- (c) Define critical load of column. Briefly describe column-strength curve according to AISC classification.
- Q.8 (a) A beam supported by steel column is as shown in figure below. Calculate the safe value of P carries by the beam. $E = 30 \times 10^6$ psi for steel.

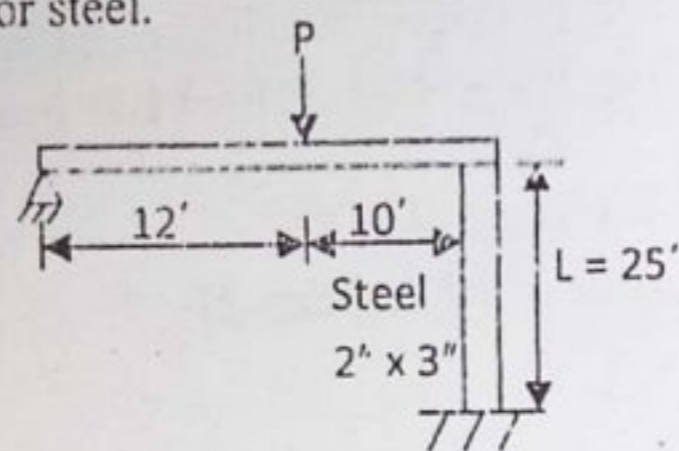

- (b) A state of stress of an element is shown in the following figure. (i) Determine the stress components that act on faces of the element rotated 15 degree clockwise (ii) Find the value of the principal stresses. 6.00

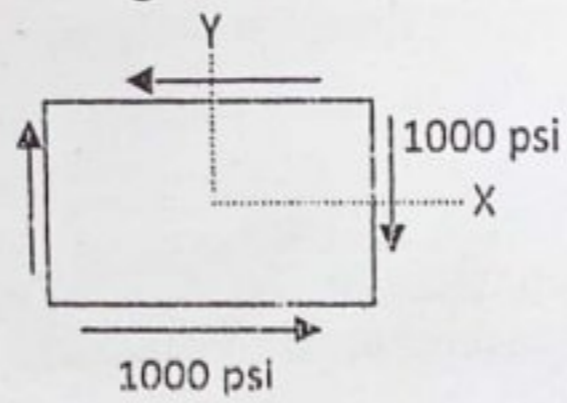

The more you practise
the more you learn

Full marks: 72

Time: 3 Hours

- N.B:-
- (i) Answer any SIX questions, taking THREE from each section.
 - (ii) Figures in the margin indicate full marks.
 - (iii) Use separate answer script for each section.
 - (iv) Assume reasonable value for any data missing.

SECTION-A

Using double-integration method, compute the value of 'Ely' midway between the supports for the following beam. 12.00

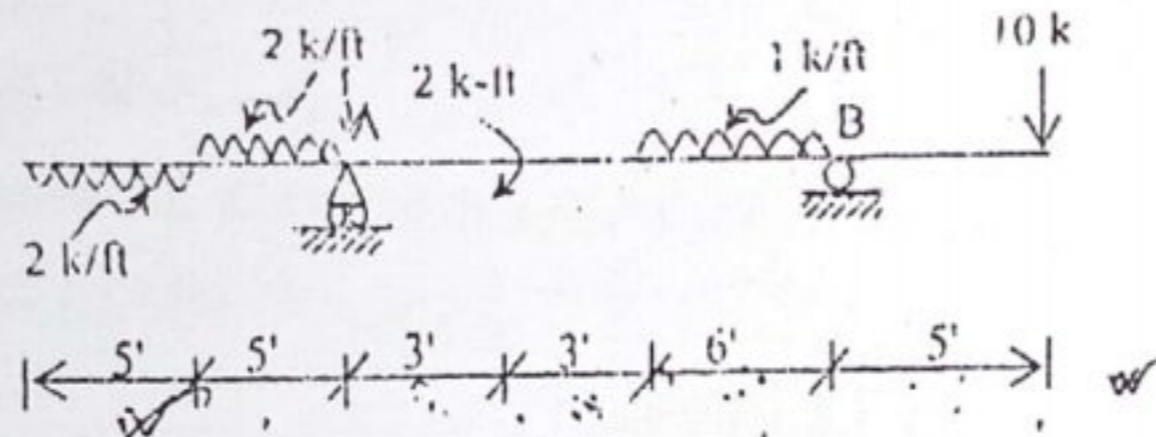

- Q.2(a) State and prove Second Area Moment Proposition. 2.00
 (b) Using area-moment method, calculate the value of maximum $EI\delta$ for the beam shown in figure below. EI is constant. 10.00

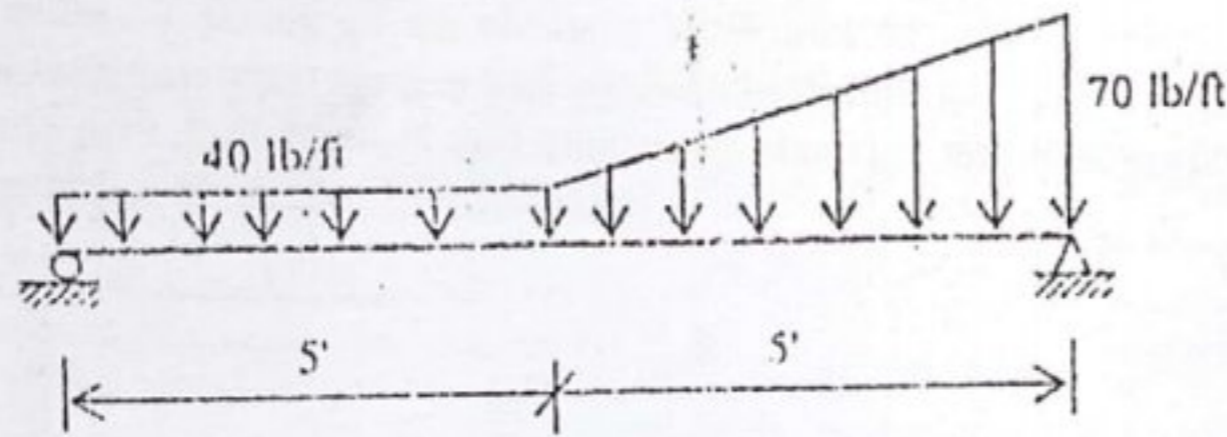

- Q.3(a) Write down the process to transform a real beam into a conjugate beam. 4.00
 (b) Transform the following real beam into a conjugate beam and draw SFD and BMD if M_B is -187.5 k-ft. 8.00

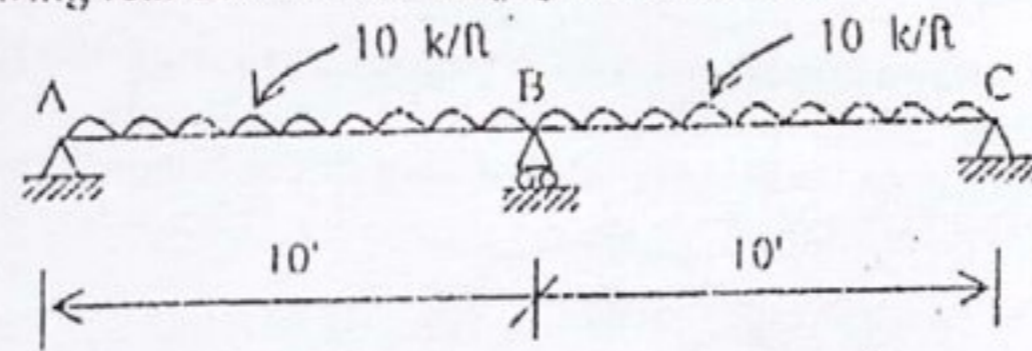

- Q.4(a) What are the assumptions and limitations of the Euler's column theory? 4.00
 (b) A T-section $15\text{ cm} \times 12\text{ cm} \times 2\text{ cm}$ is used as a strut of 4m long with hinged at its both ends. Calculate the crippling load if Young's modulus for the material is $2.0 \times 10^6\text{ kg/cm}^2$. 8.00

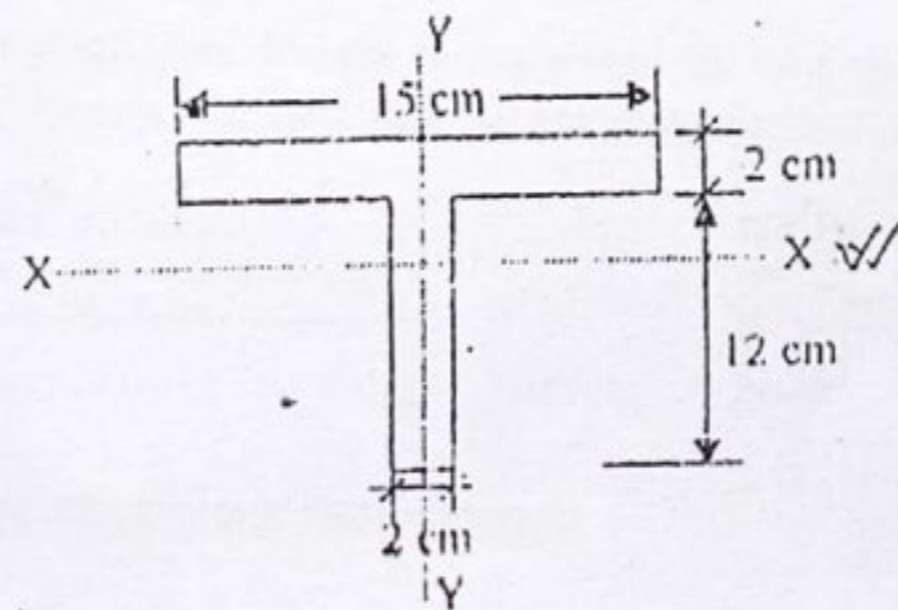

SECTION-B

- Q.5(a) Derive the torsion formula to determine maximum stress in a circular shaft. 3.00
 (b) A shaft composed of segment AC, CD and DE fastened to rigid supports and loaded as shown in figure below. For bronze $G=35\text{ GPa}$, for aluminum $G=28\text{ GPa}$ and for steel $G=83\text{ GPa}$. Determine the maximum shearing stress developed in each segment. 9.00

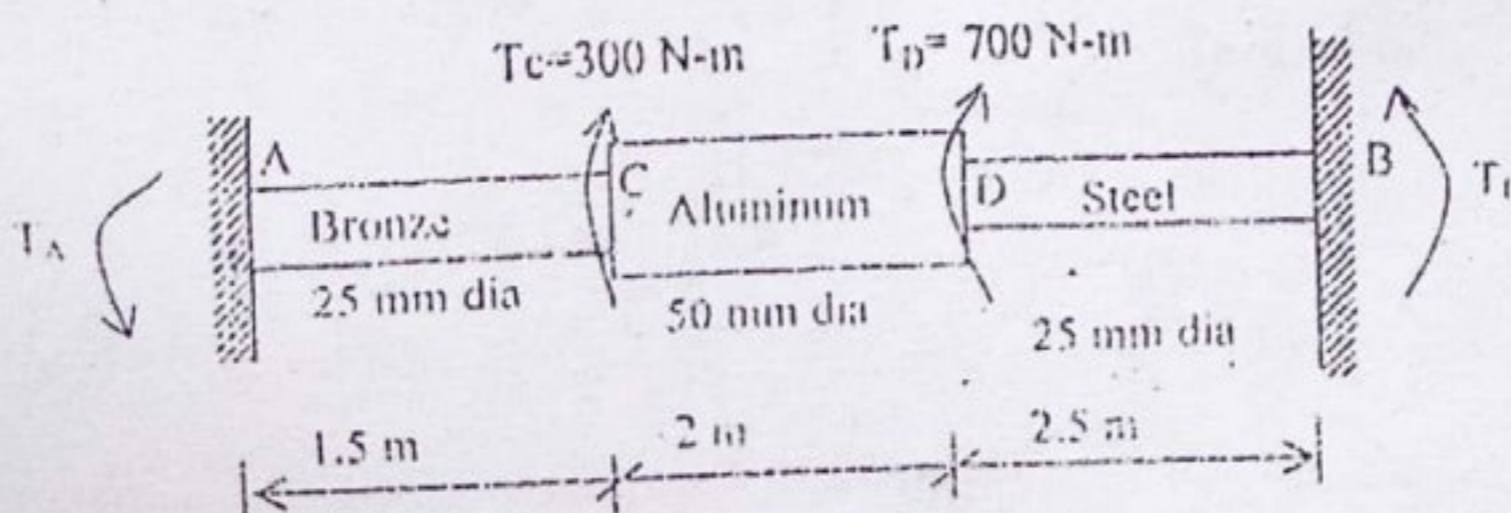

Full marks: 72

Time: 3 Hours

- N.B:- (i) Answer any SIX questions, taking THREE from each section.
 (ii) Figure in the margin indicate full marks.
 (iii) Use separate answer script for each section.
 (iv) Assume reasonable value for any data missing

SECTION-A

- Q.1 (a) Illustrate the following two theorems of area-moment method. (i) $\theta_{AB} = \frac{1}{EI} (AREA)_{AB}$ 04
 (ii) $t_{B/A} = \frac{1}{EI} (AREA)_{AB} \cdot \bar{x}_B$

- Q.1 (b) Determine the value of $EI\delta$ at the right end of the overhanging beam shown in the following figure. 08

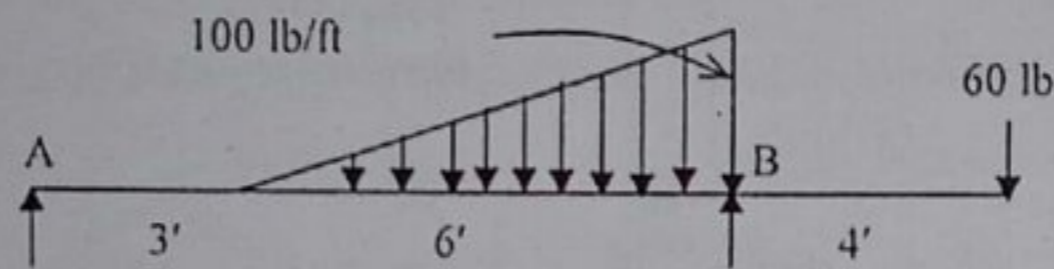

- Q.2 (a) Draw the state of stress of an element subjected to simultaneous flexure and torsion and derive illustration for equivalent torque and equivalent moment. 04

- (b) Calculate the principal stresses and maximum shearing stress at point A and B of the following figure at section $x = 12$ inch due to $P = 12,000$ lb. 08

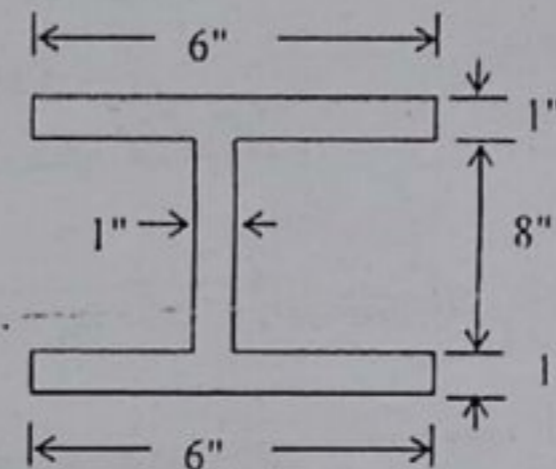
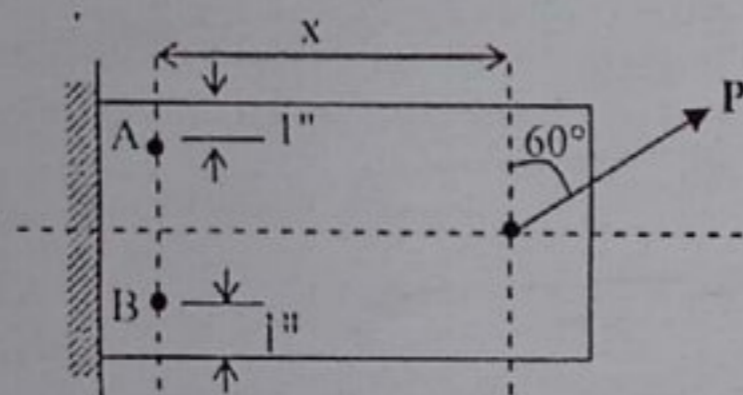

- Q.3 (a) Ten 1/2 inch diameter bolts are arranged in two concentric circles in a flanged coupling similar to that shown in the following figure. Find the maximum horse power that can be transmitted by the coupling if the shaft speed is 315 rpm and the maximum permissible shearing stress is 5000 psi. 06

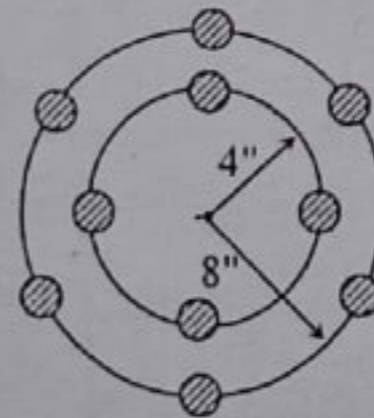

- (b) A rigid horizontal bar of negligible weight is supported by two springs as shown in the following figure. Determine the distance 'x' in order that the bar remains horizontal after a load 'P' is applied. 06

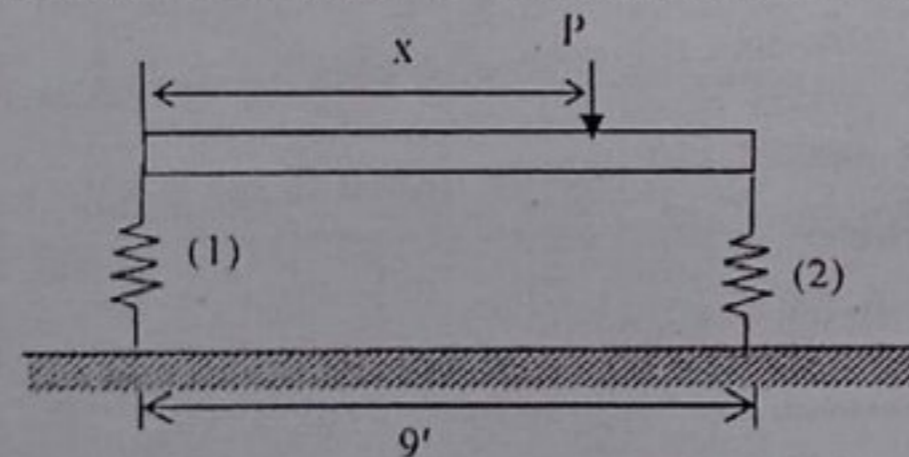

<u>Spring-1</u>	<u>Spring-2</u>
$d = 0.25''$	$d = 0.40''$
$R = 1.0''$	$R = 2.0''$
$n = 25$	$n = 10$
$G = 12 \times 10^6$ psi	

- Q.4 (a) Derive an expression for solid and hollow circular shaft for maximum shearing stress. 04

- (b) Two steel shafts are gear connected as shown in the following figure. Find the angle of twist of end D if shaft CD is subjected to a twisting moment of 10,000 lb-in. $G = 12 \times 10^6$ psi. 08

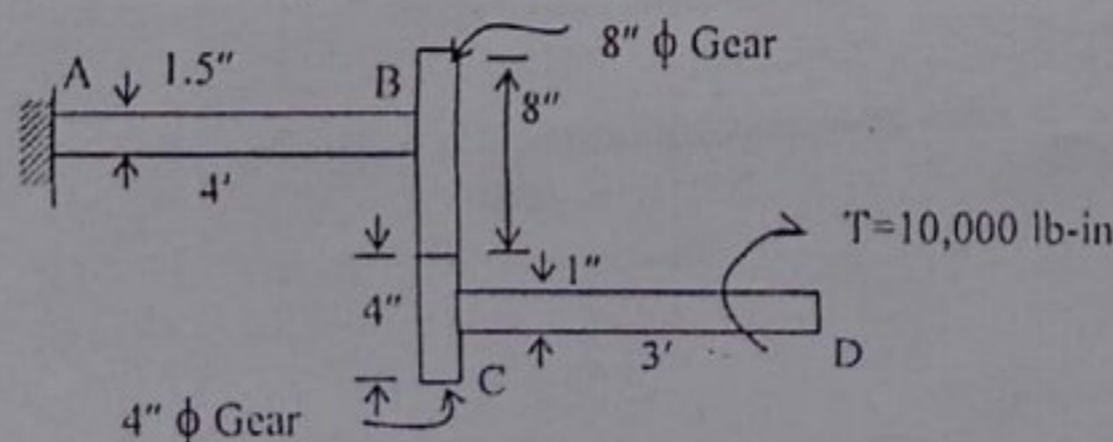

SECTION-B

- Q.5 (a) Write the relationships between the real beam and conjugate beam. Using conjugate beam method, find (i) The deflection of 'E' (ii) The deflection of 'B' and (iii) Slope of 'B'. Given $E=30,000$ ksi. 03
09

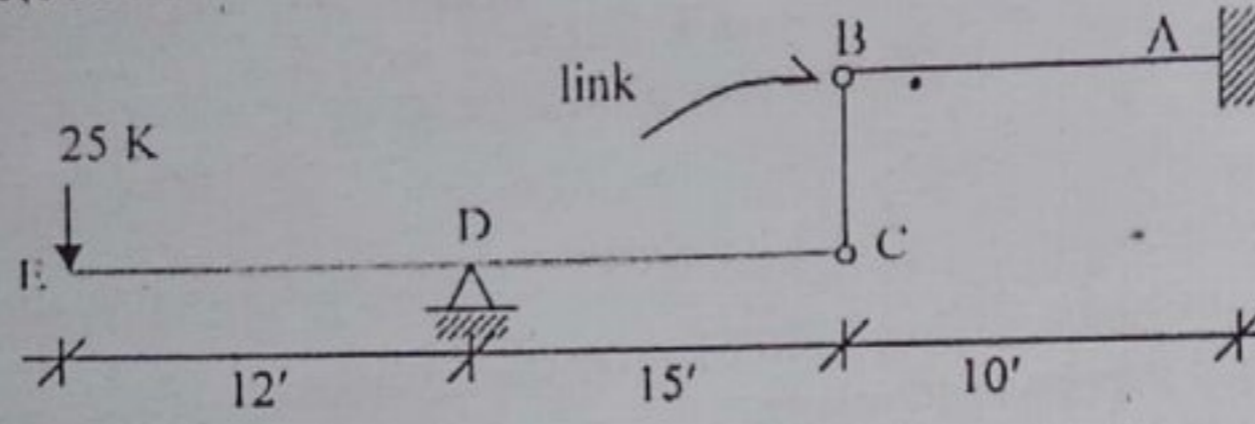

- Q.6 (a) Deduce the expression given by Euler for the critical load for a column length L , modulus of elasticity E , moment of inertia I , when both ends are hinged. 05
- (b) A T-section $16\text{ cm} \times 12\text{ cm} \times 3\text{ cm}$ is used as a strut of 5 m long with hinged at its both ends. Calculate the crippling load, if Young's modulus for the material is $2 \times 10^6\text{ kg/cm}^2$. 07

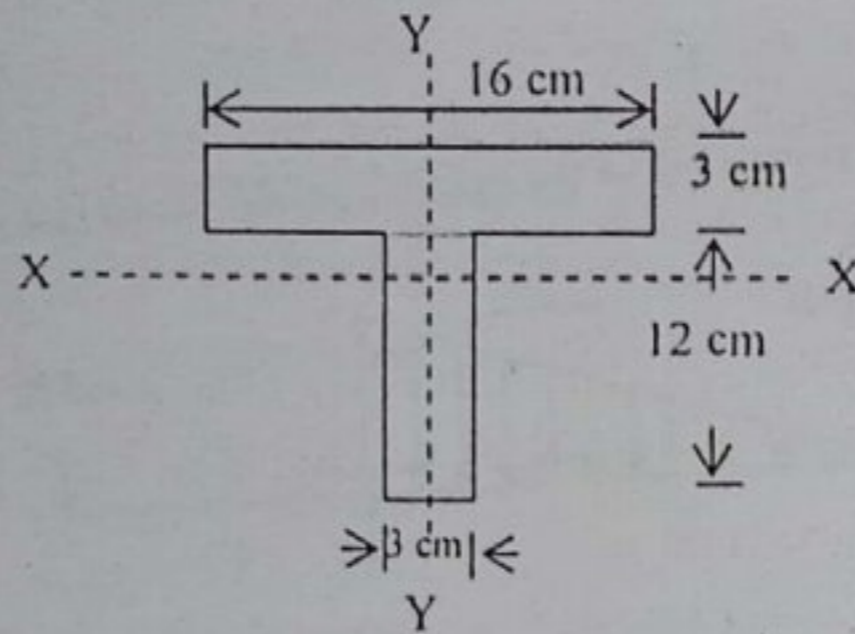

- Q.7 An overhanging beam ABC is shown in figure below. Using double integration method, calculate the value of rotational deflection of the beam. EI is constant. 07

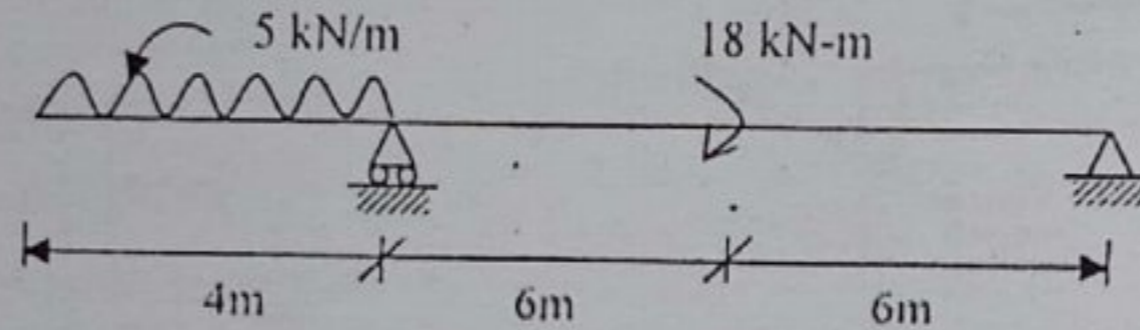

- (b) A concrete dam has the profile as shown in figure below. If the density of concrete is 2400 kg/m^3 and that of water is 1000 kg/m^3 . Determine the maximum compressive stress on section m-n if the depth of water behind the dam $h=14\text{ m}$. 05

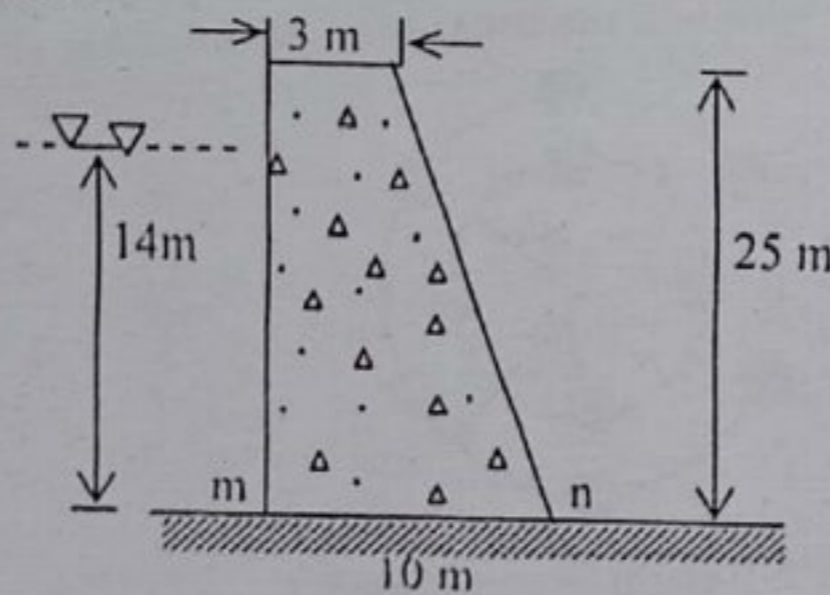

- Q.8 (a) What is the significance of kern of a section? Show that the kern of a circular section is a circle whose diameter is one-quarter the diameter of the section. 03
- (b) A rectangular pier is subjected to a compressive load of 120 kips as shown in the figure. Find the stress intensities on all the four corners of the pier. 06

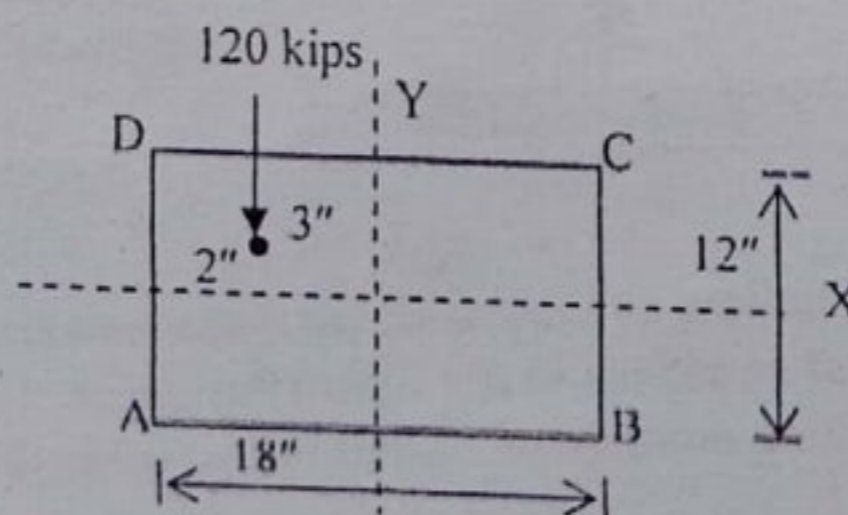

- (c) Derive the torsion formula to determine maximum stress in a circular shaft. 03

Full marks: 40

Time: 3 Hours

- N.F:-
 (i) Answer any SIX questions, taking THREE from each section.
 (ii) Figure in the margin indicate full marks.
 (iii) Use separate answer script for each section.
 (iv) Assume reasonable value for any data missing.

$$\frac{16PR^3}{813} \left(1 + \frac{d}{4R}\right)$$

SECTION-A

- Q.1 (a) What are the techniques to transform a real beam into a conjugate beam? 1.67
 (b) State the relationship between an actual beam and a conjugate beam. 2.00
 (c) A continuous beam is shown in figure below. Draw the corresponding conjugate beam with load diagram. 4.00

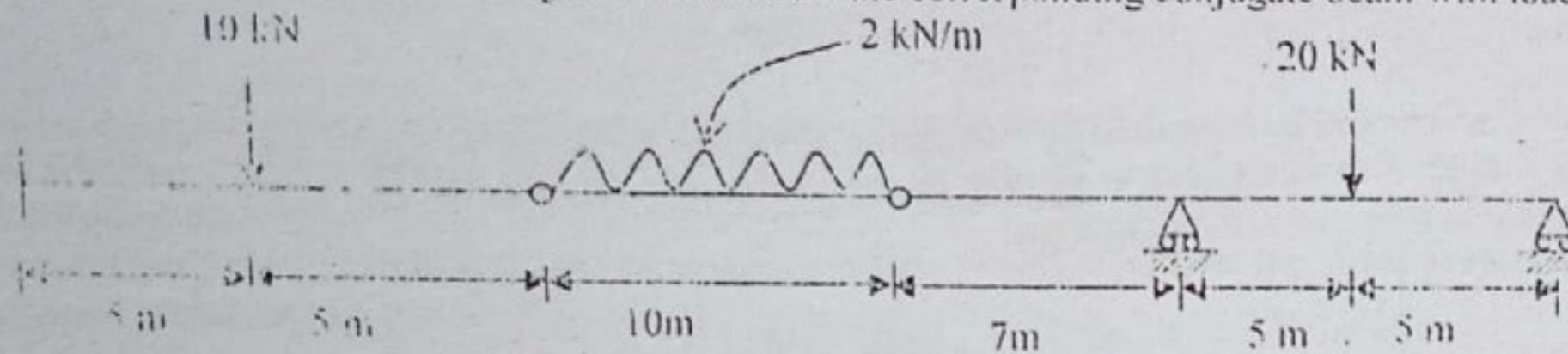

- (d) A conjugate beam is shown in figure below. Transform the conjugate beam into a real beam with respective loads. 4.00

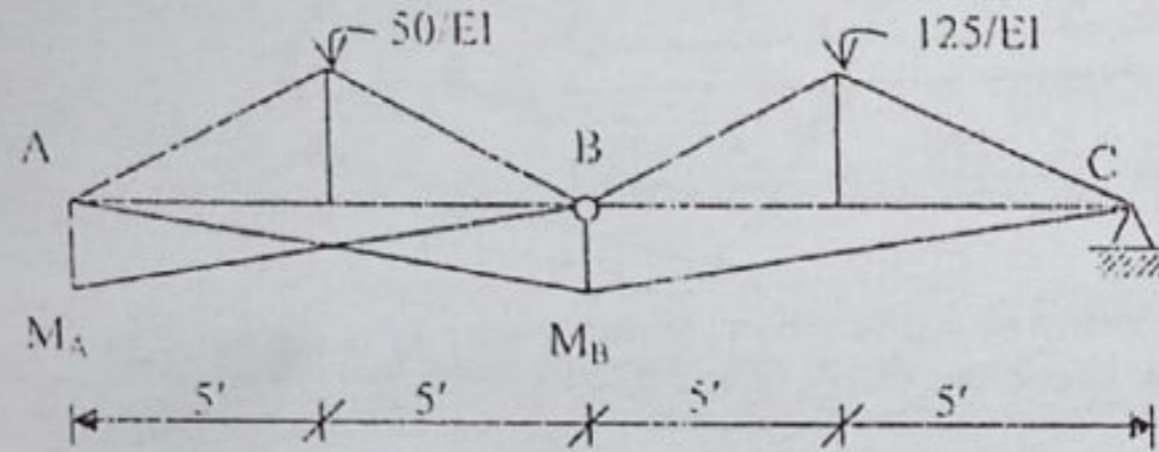

- Q.2 Find the reactions and maximum deflection of the restrained beam shown in the figure below. Sketch the SFD and BMD and indicate the critical values. Use area-moment method. 11.67

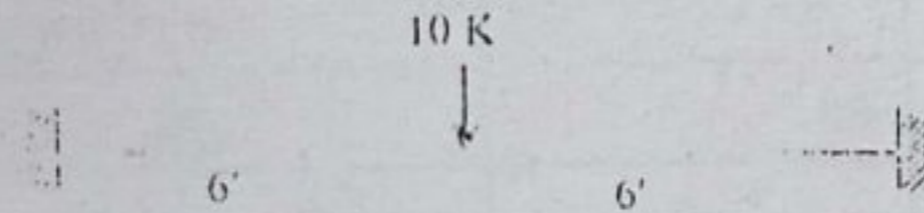

$$\frac{10 \times 95}{10}$$

- Compute the value of 'EIv' midway between the supports for the beam shown below. 11.67

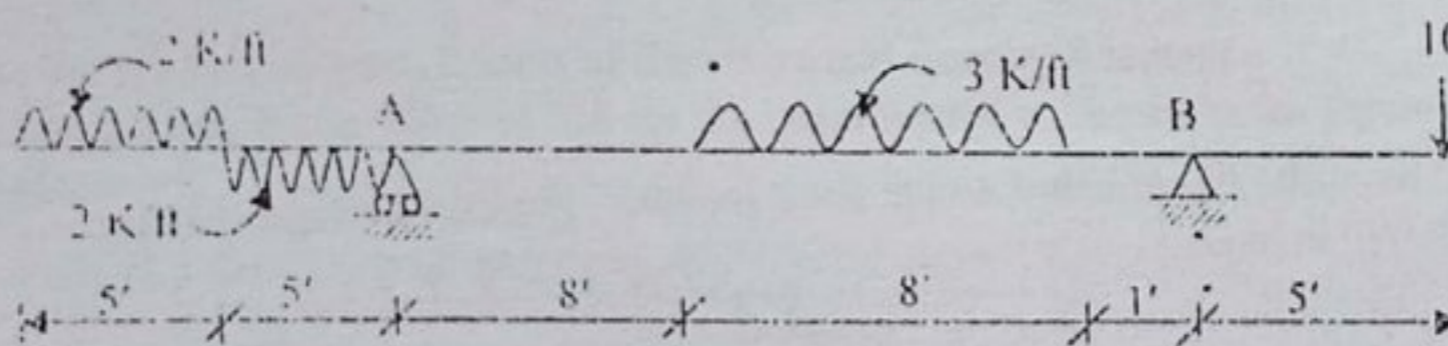

- Q.3 (a) Derive the torsion formula to determine maximum stress in a circular shaft. 2.67
 (b) A shaft composed of segment AC, CD, and DB is fastened to rigid supports and loaded as shown in fig. below. For bronze $G = 35$ GPa, for aluminum $G = 28$ GPa and for steel $G = 83$ GPa. Determine the maximum shearing stress developed in each segment. 9.00

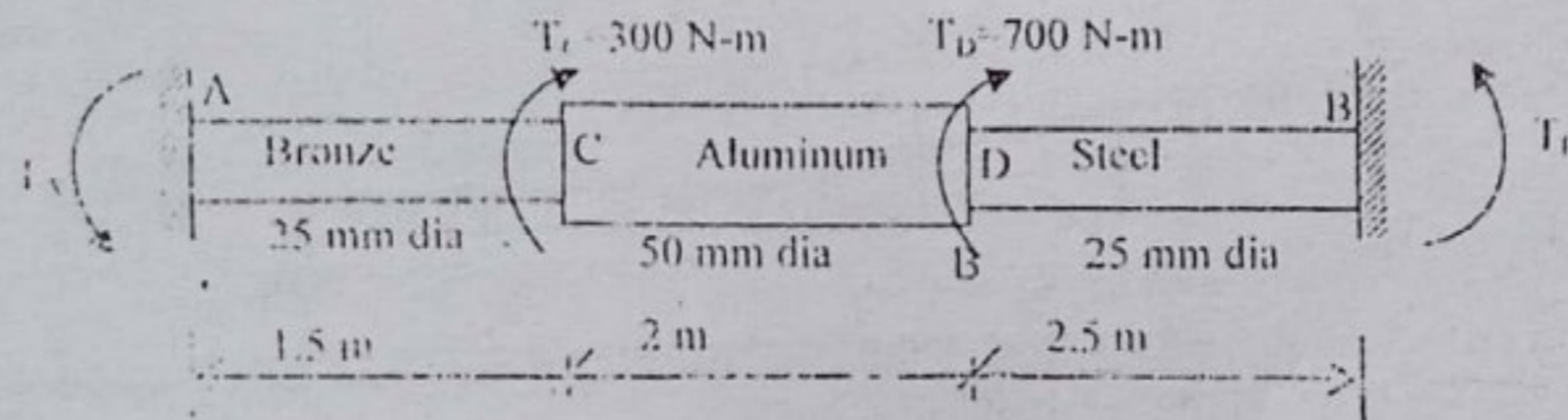

$$\frac{20 \times 5 \times 1}{10}$$

$$\frac{\pi r^3}{4}$$

SECTION-B

- Q.4 (a) What is the significance of kern of a section? Show that the kern of a circular section is a circle whose diameter is one-quarter the diameter of the section. 4.67
 (b) A rectangular pier is subjected to a compressive load of 100 kips as shown in figure. Find the stress intensities on all the four corner of the pier. What additional minimum load acting normal to the x-section at its centroid will eliminate tensile stress anywhere over the cross-section. 7.00

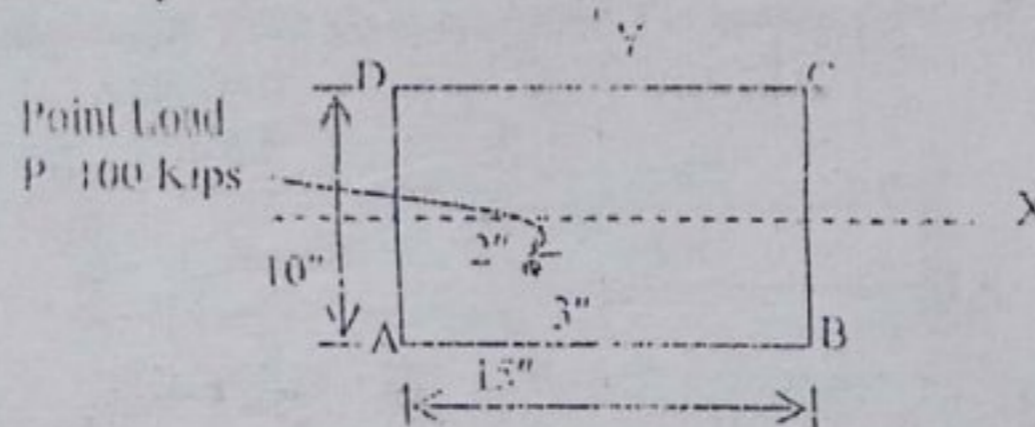

$$\left\{ \begin{aligned} \sigma_1 &= \frac{TC}{J} \\ \sigma_2 &= \frac{TL}{GJ} \end{aligned} \right.$$

32x10
 32x10

- Q.7 (a) Derive an expression for simultaneous bending and twisting.
 (b) Define the following terms (i) Principal stress (ii) Principal plane (iii) Mohr's circle.

(c) A state of stress of an element is shown in the following figure. Determine the normal and shearing stresses on (a) the principle planes (b) the planes of maximum in-plane shearing stress and (c) the planes whose normals are at $+36.8^\circ$ and $+126.8^\circ$ with the x axis, show the results of parts (a) and (b) on complete sketches of differential elements.

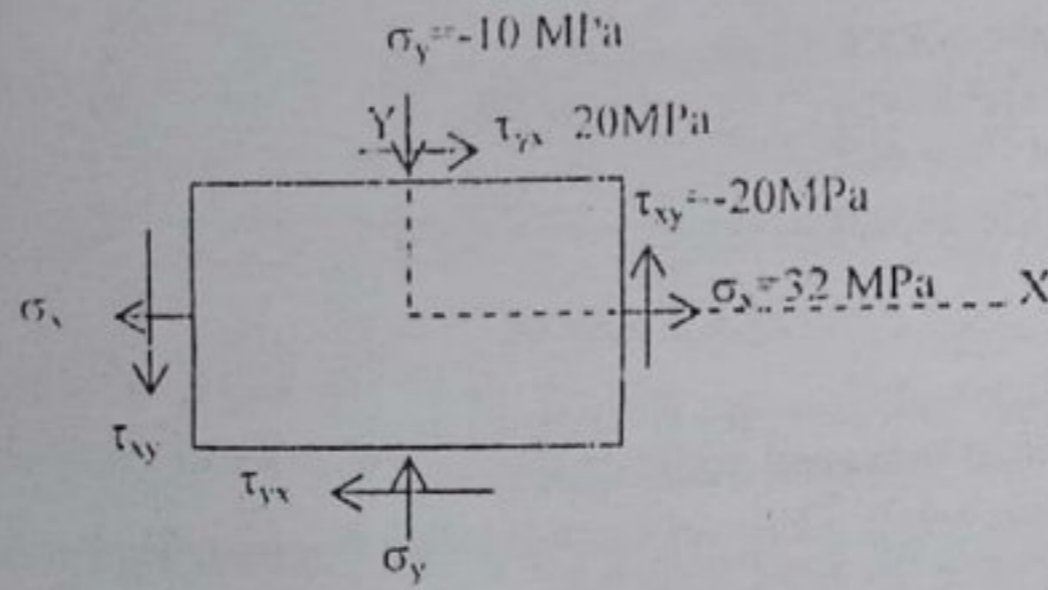

Q.7 (a) A rigid bar hinged at one end is supported by two identical springs as shown in figure below. Each spring consists of 20 turns of 10 mm wire having a mean diameter of 150 mm. Compute the maximum shearing stress in the springs, neglecting the mass of the rigid bar.

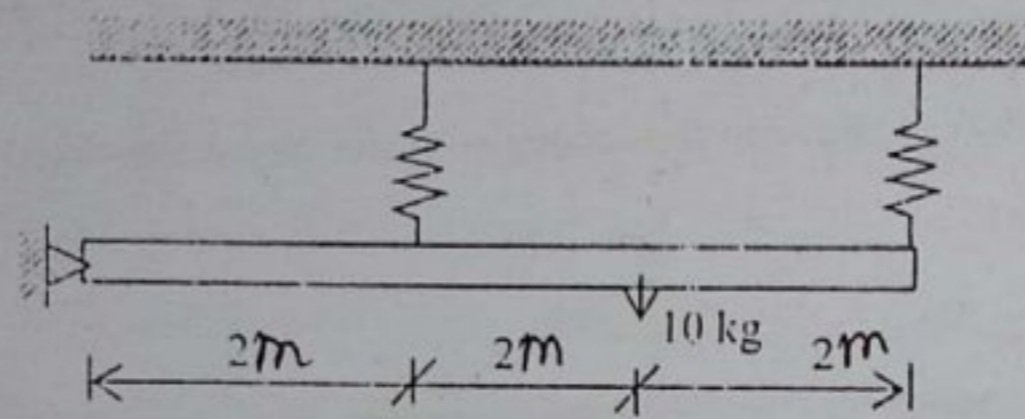

(b) A concrete dam has the profile as shown in figure below. If the density of concrete is 2400 kg/m^3 and that of water is 1000 kg/m^3 . Determine the maximum compressive stress on section m-n if the depth of water behind the dam $h=12 \text{ m}$.

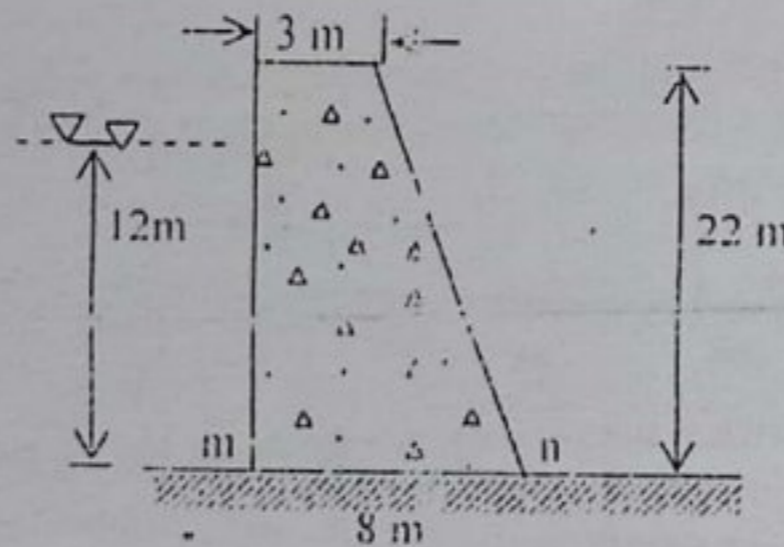

$$\frac{d}{4} \frac{P}{\pi d^2} \times \frac{d}{4}$$

$$= \frac{4P}{\pi d^2}$$

$$= \frac{P}{\frac{\pi d^2}{4}}$$

Q.8 (a) Six $7/8 \text{ in}$ rivets fasten the plate as in the figure below to the fixed member. Find the average shearing stress caused in each rivet by the $P = 10,000 \text{ lb}$ loads.

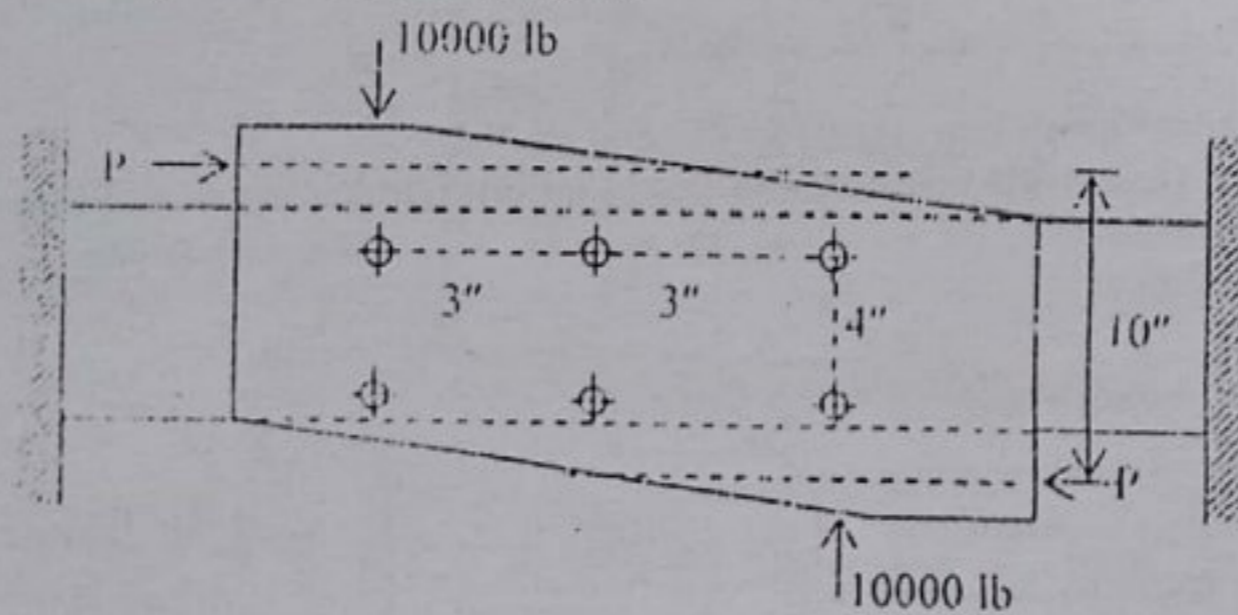

(b) An 'I' section $15 \text{ cm} \times 12 \text{ cm} \times 2 \text{ cm}$ is used as a strut of 4 m long with hinged at its both ends. Calculate the crippling load, if Young's modulus for the material is $2.0 \times 10^6 \text{ kg/cm}^2$.

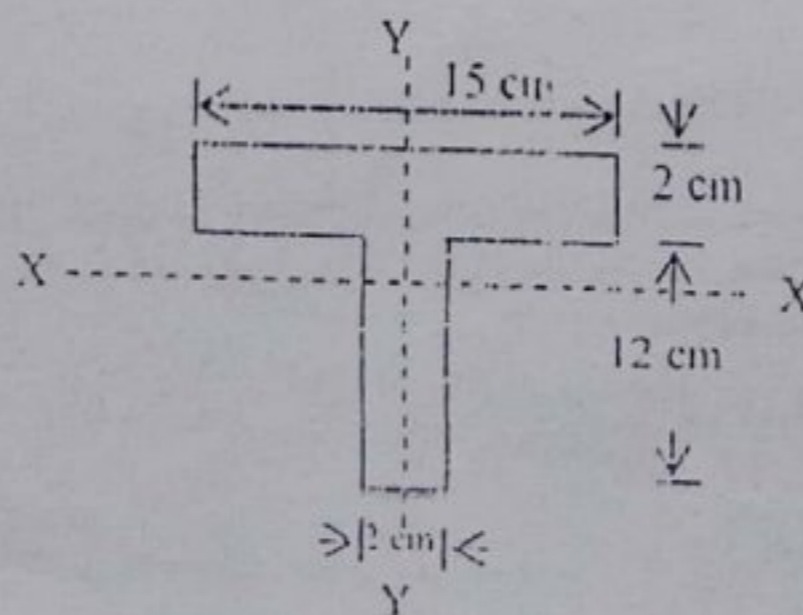

Full marks: 70

Time: 3 Hours

- N.B:-
- (i) Answer any **SIX** questions, taking **THREE** from each section.
 - (ii) Figure in the margin indicate full marks.
 - (iii) Use separate answer script for each section.
 - (iv) Assume reasonable value for any data missing.

SECTION-A

- Q.1 (a) What are the assumptions and limitations of the Euler's column theory? 3.00
 (b) What is the significance of kern of a section? Show that the area of kern of a square section is 1/18 th of the total cross sectional area. 3.00
 (c) A compressive load $P=15000$ lb is applied as shown in figure below. Compute the stress at each corner and the location of the neutral axis. 5.67

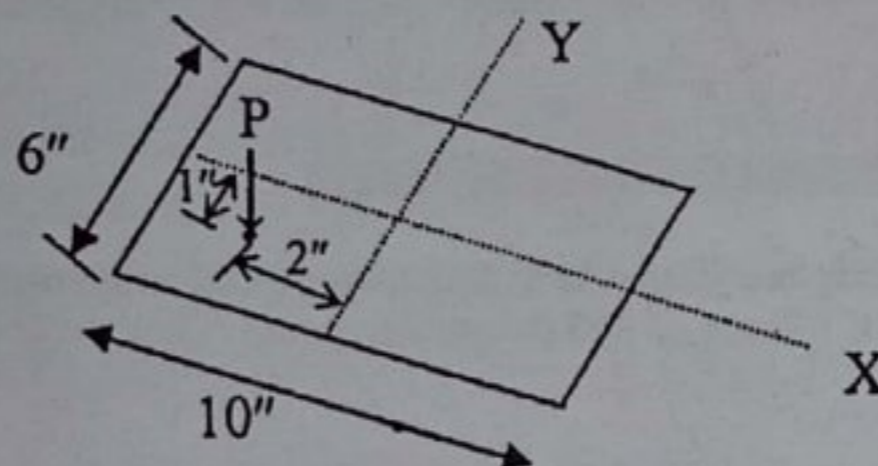

- Q.2 (a) Write the relationships between the real beam and conjugate beam. 2.67
 (b) A continuous beam is shown in figure below. Draw the corresponding conjugate beam with load diagram. 9.00

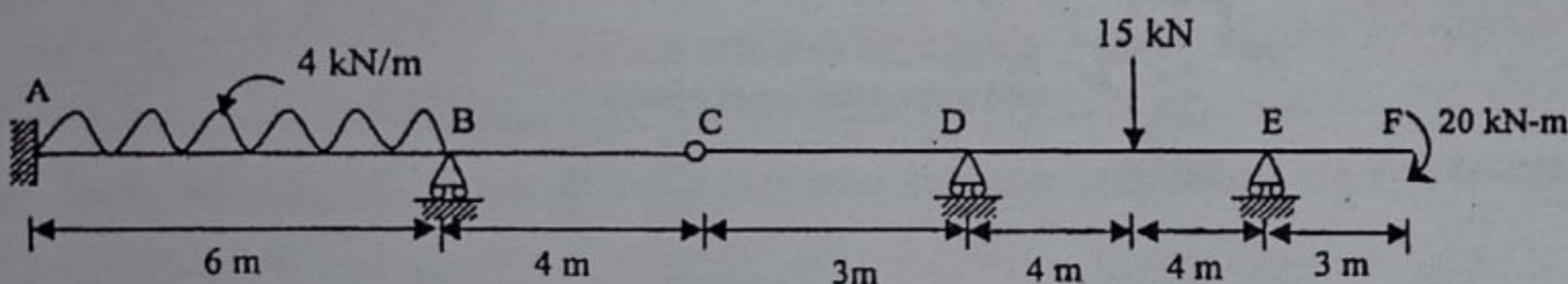

- Q.3 (a) Derive the relation between Radius of Curvature and Bending Moment. 2.67
 Calculate the maximum value of $EI\delta$ for the beam loaded as shown in the figure below by Double Integration method. 9.00

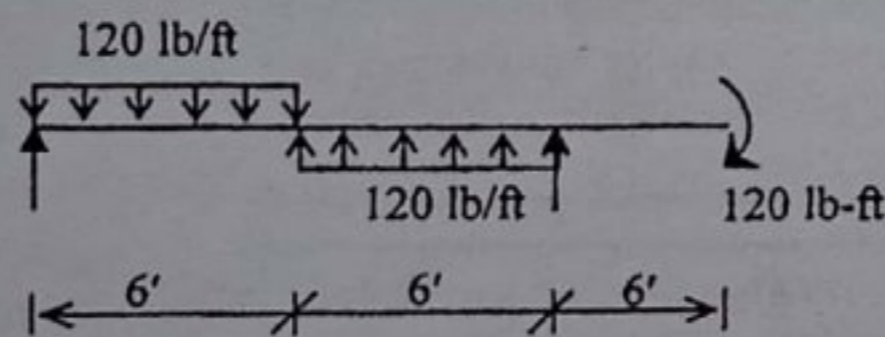

- Q.4 Using area-moment method, calculate the value of maximum $EI\delta$ for the beam shown in figure below. EI is constant. 11.67

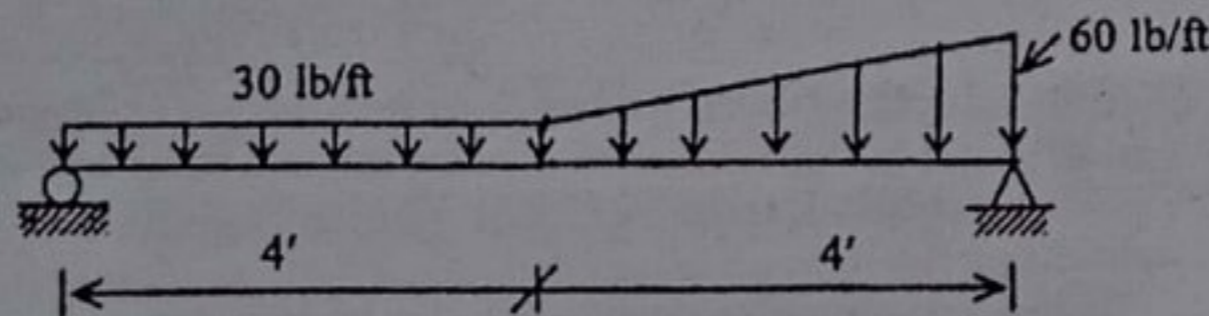

SECTION-B

- Q.5 (a) Derive the torsion formula to determine maximum stress in a circular shaft. 2.00
 (b) The compound shaft is shown in figure below which is attached to rigid supports. For the bronze segment AB, the maximum shearing stress is limited to 8000 psi and for the steel segment BC, it is limited to 12 ksi. Determine the diameters of each segment so that each material will be simultaneously stressed to its permissible limit when a torque $T=12$ kip-ft is applied. For bronze, $G=6 \times 10^6$ psi and for steel, $G=12 \times 10^6$ psi. 9.67

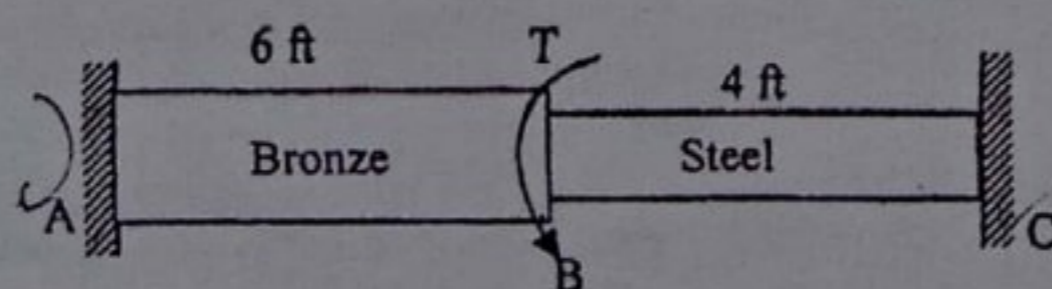

Q.6 (a) Compute the principal stresses and maximum shearing stress at point A and B in the following figure.

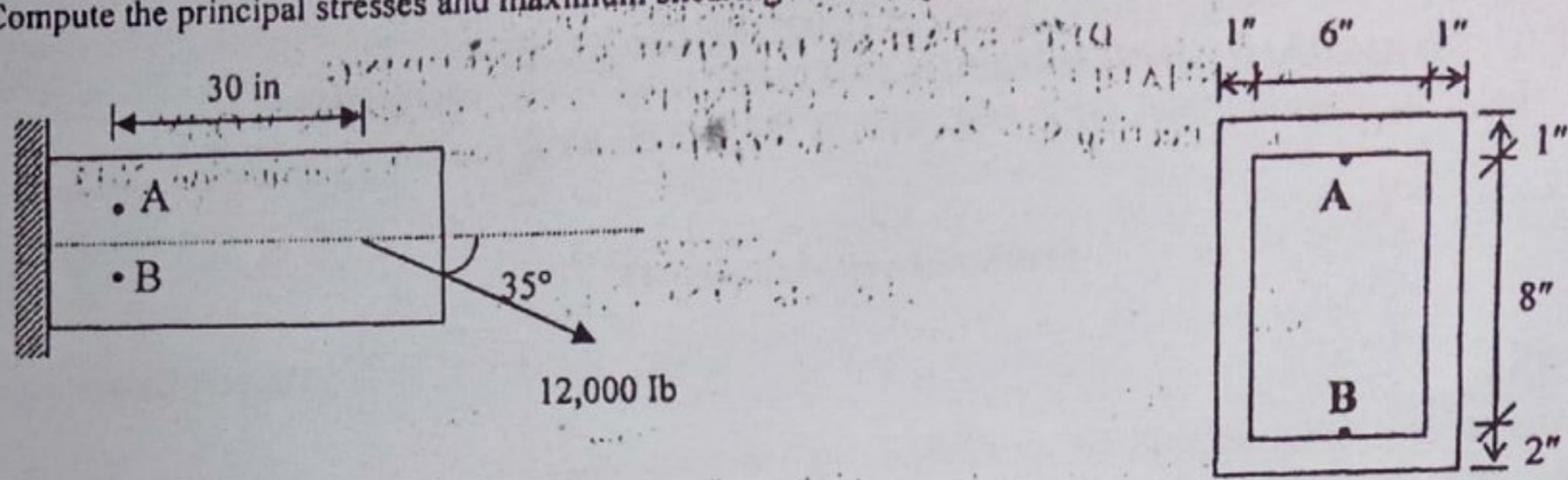

(b) A concrete dam has the profile as shown in figure below. If the density of concrete is 2400 kg/m^3 and that of water is 1000 kg/m^3 , determine the maximum compressive stress on section m-m if the depth of the water behind the dam is $h=15\text{m}$. 6.67

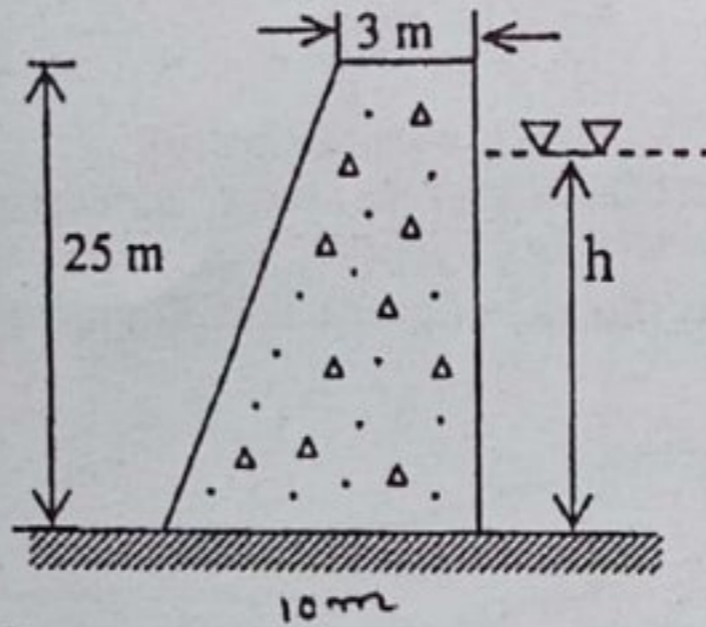

Q.7 (a) Two springs as in the following figure, are joined at C and then placed, unstressed, below the supports A and B. Find the reactions at the supports if a force of 600 lb acts as shown ($G=12 \times 10^6 \text{ psi}$). 5.00

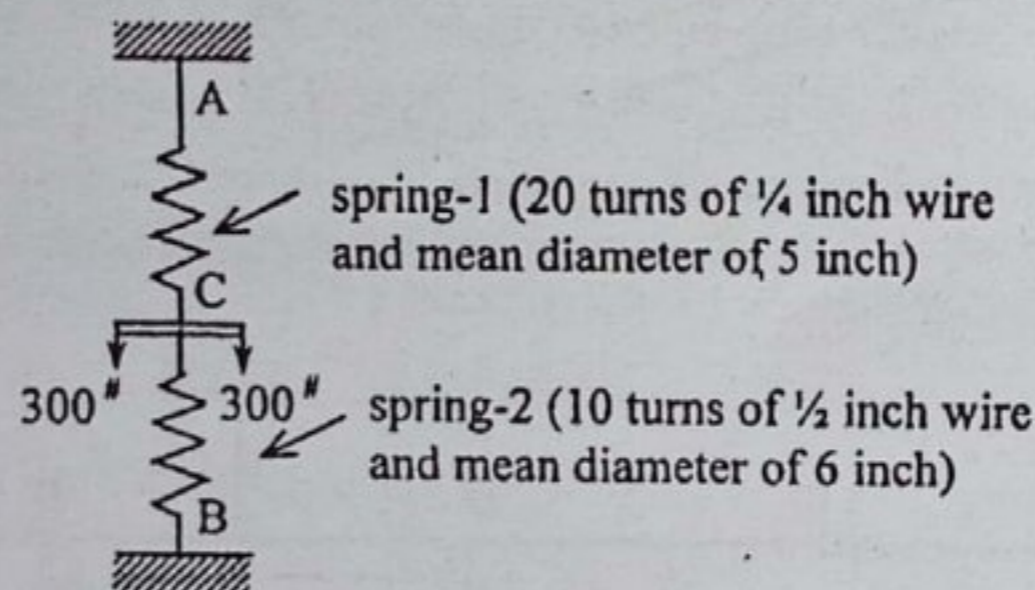

(b) A rigid bar, pinned at point O, is supported by two identical springs as shown in figure below. Each spring consists of 20 turns of $3/4 \text{ in.}$ diameter wire having a mean diameter of 6 in. Determine the maximum load W that may be supported if the shearing stress in the springs is limited to 20 ksi. 6.67

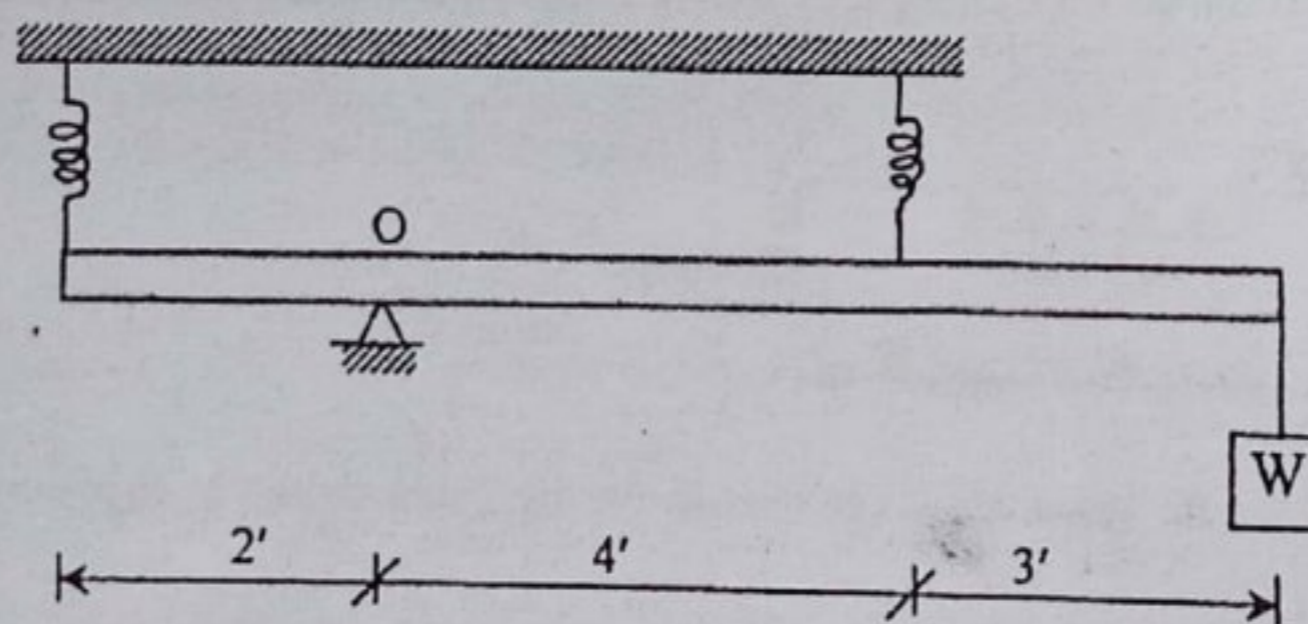

Q.8 (a) Using general equation of elastic curve, determine the Euler's formula for a pin ended long column. 3.67
 (b) A beam supported by steel column as shown in figure below. Calculate the safe value of P carries by the beam. 8.00
 E is $30 \times 10^6 \text{ psi}$ for steel.

