



Experiment Number: 02

Experiment Name: Determination of the direct shear test of the mild steel

Introduction:

- **Shearing Stress:**

- When an external force acts on an object, It undergoes deformation. If the direction of the force is parallel to the plane of the object. The deformation will be along that plane. The stress experienced by the object here is shear stress or tangential stress.
- It arises when the force vector components which are parallel to the cross-sectional area of the material. In the case of normal/longitudinal stress, The force vectors will be perpendicular to the cross-sectional area on which it acts.



Introduction:

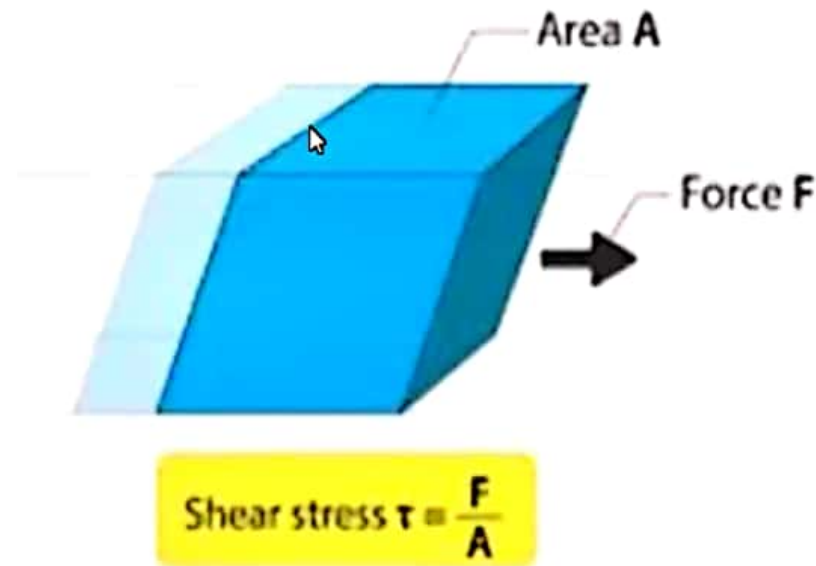

Where,

- τ is the shear stress
- F is the force applied.
- A is the area of cross-section, that is parallel to the force vector.

Rivet:

A **rivet** is a mechanical fastener composed of a head-on one end and a cylindrical stem on another (called the tail) which has the appearance of a metal pin.

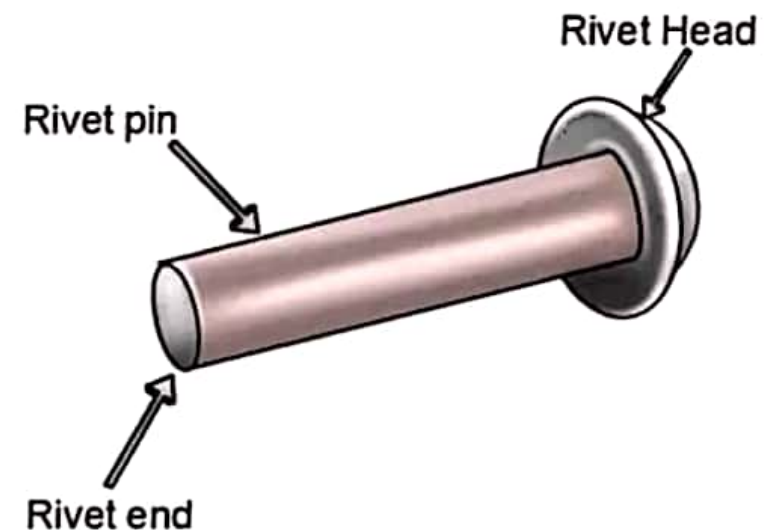

Types of Riveted and Bolted Joints:

There are two types of riveted and bolted joints.

- (i) Lap joints (ii) Butt joints

In **lap joints** the components to be joined overlap each other, while for **butt joints** an additional piece of material is used to bridge the two components to be joined which are butted up against each other.

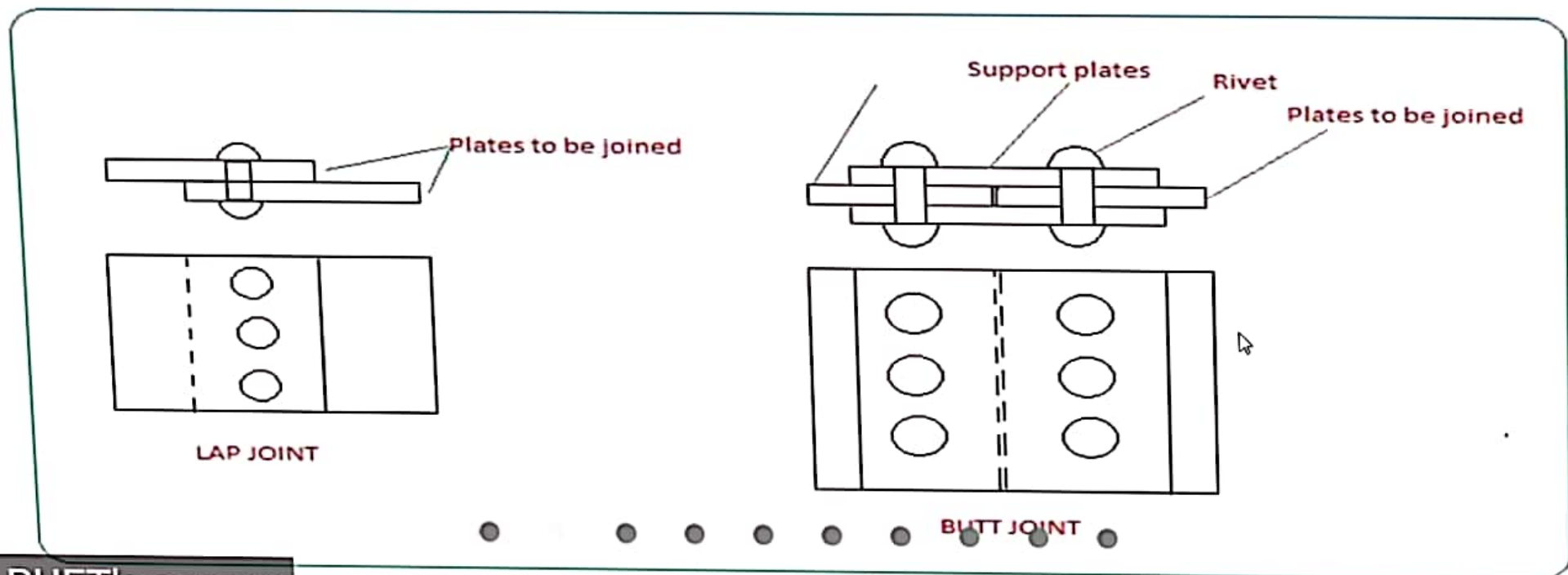

Single Shear

$$\tau = \frac{F}{A}$$

$$\tau = \frac{F}{\pi(r)^2}$$

$$\tau = \frac{4F}{\pi(D)^2}$$

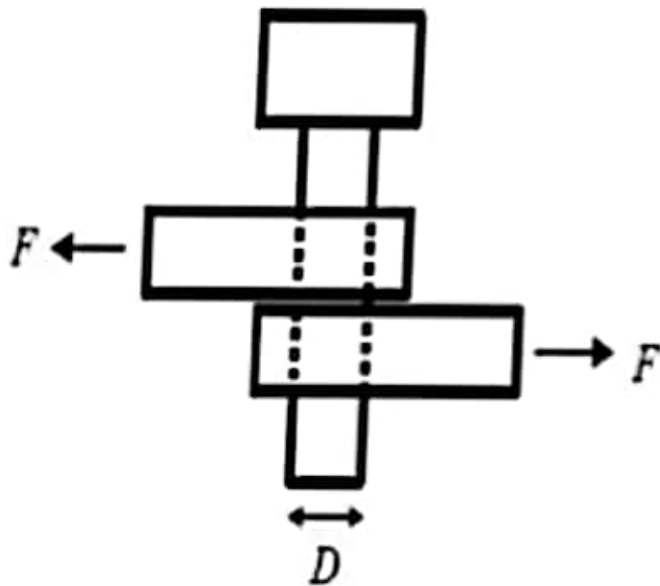

- Single shear is load applied in one plane
- When single cross section of an element in a joint takes all the shear force it is called single shear

Double Shear

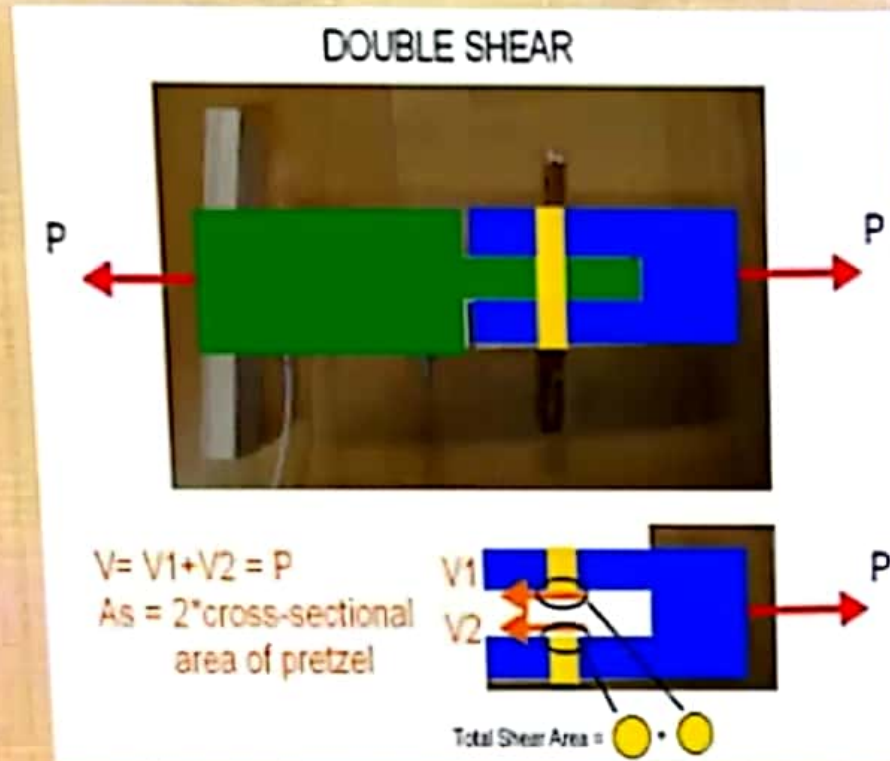

- When two cross sections of the element takes the shear load it is called double shear
- Double shear is moire safer and has higher safety factor

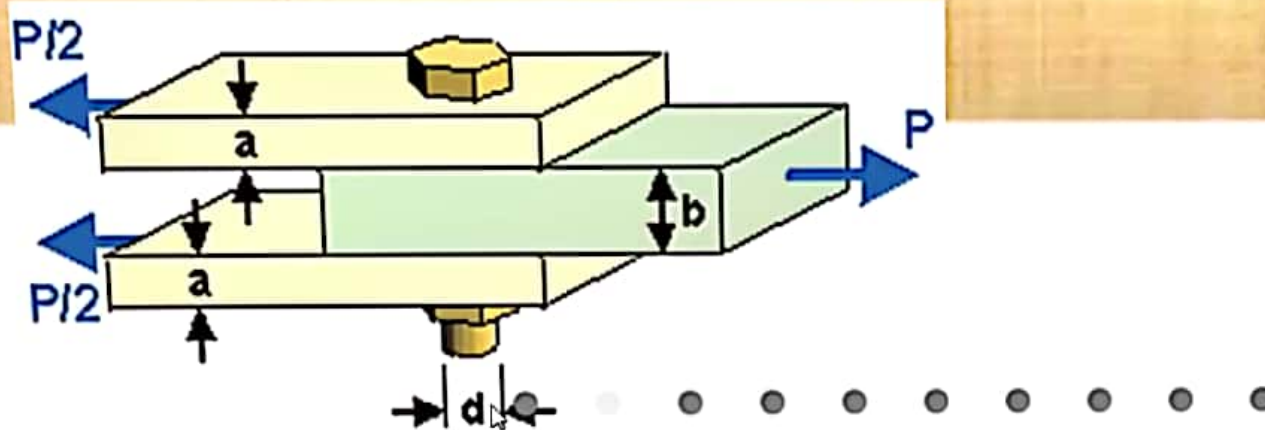

Possible Failure Modes

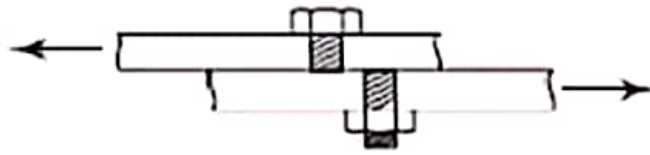

Shear failure of bolt
(a)

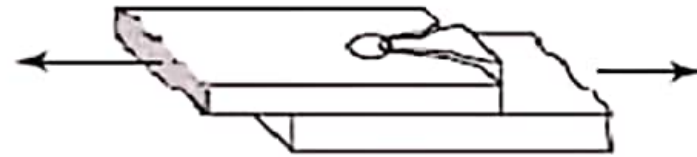

Shear failure of plate
(b)

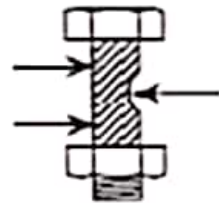

Bearing failure of bolt
(c)

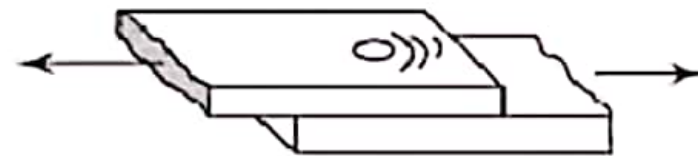

Bearing failure of plate
(d)

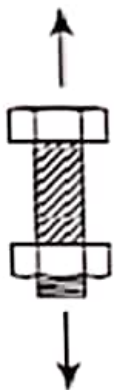

Tensile failure of bolts
(e)

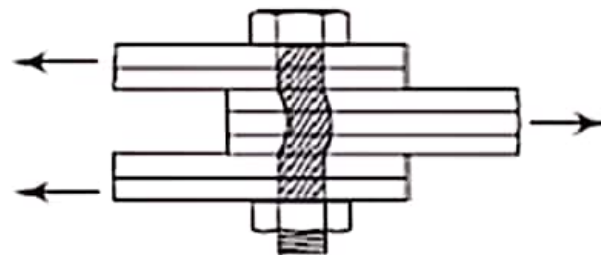

Bending failure of bolts
(f)

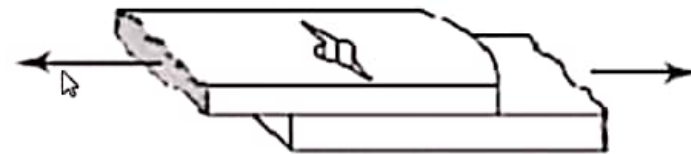

Tensile failure of plate
(g)

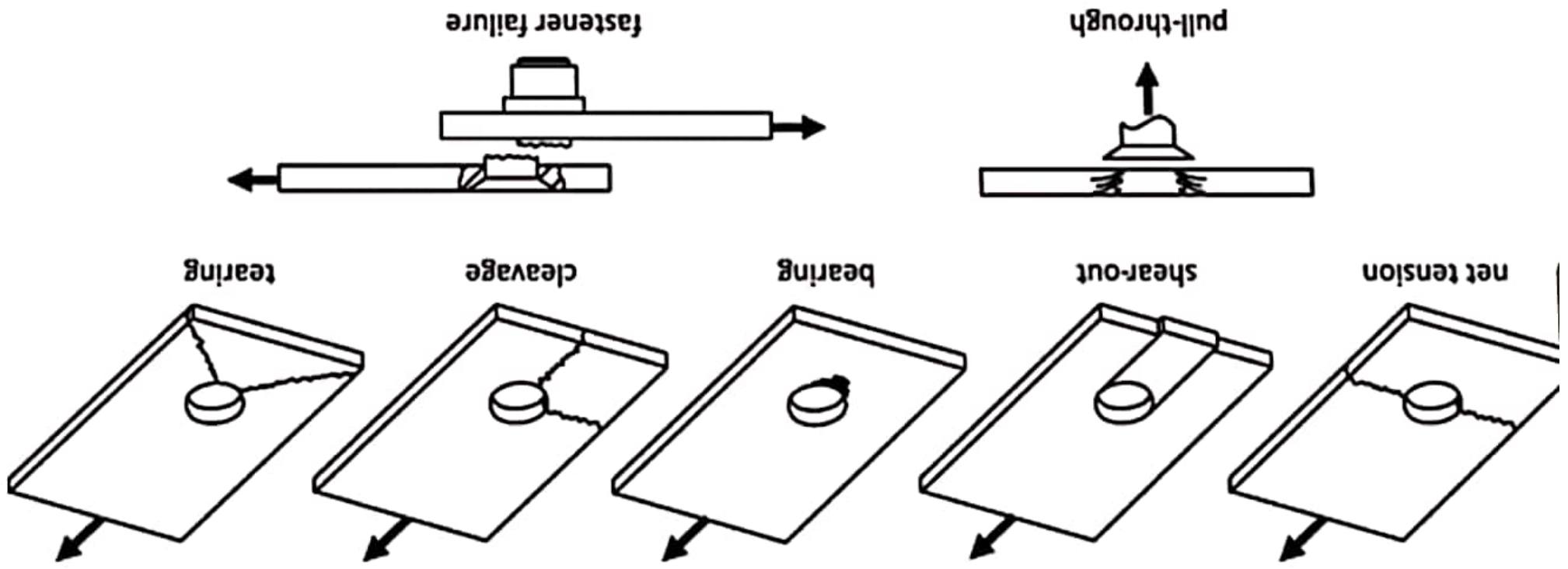

Objectives:

- (i) To determine the shearing stress of rivet.



Apparatus:

- Slide Calipers
- Universal Testing Machine (**UTM**)
- Hammer
- Rivet
- Steel plate
- Drill Machine

Observation Sheet & Calculations:

- Diameter of rivet (d) = cm
- Strength of rivet (P) = kN (From UTM machine)
- Area of the rivet (A) = $\pi d^2 / 4$ cm²
- Shearing Stress, $S_s = P / A$ kN/cm²



Data Table:

Sample No.	Diameter of rivet (mm)	Area (cm ²)	Load (kN)	Shearing Stress S_s (kN/cm ²)	Average Shearing Stress S_s (kN/cm ²)
1.	9.4	I	42		
2.	9.6		43		
3.	9.8		45		

Click to add title

Results:

I

Discussions: