



Experiment Number: 06

Experiment Name: Determination of Buckling Test of Slender Column



Introduction:

- **Column:** A **column** is a compression member that is so slender compared to its length that under gradually increasing loads it fails by buckling at loads considerably less than those required to cause failure by crushing.

➤ Long Columns – Fail by buckling/ Excessive lateral bending

$$\left(\frac{L}{r} > 100 \right)$$

➤ Intermediate Columns - Fail by combination of buckling and crushing

$$\left(\frac{L}{r} = 100 \right)$$

➤ Short Columns - Fail by crushing $\left(\frac{L}{r} < 30 \right)$



Slenderness ratio: The ratio L/r is called the **slenderness ratio** of the column. Since an axially loaded column tends to buckle about the axis of least moment of inertia, the least radius of gyration should be used to determine the slenderness ratio.

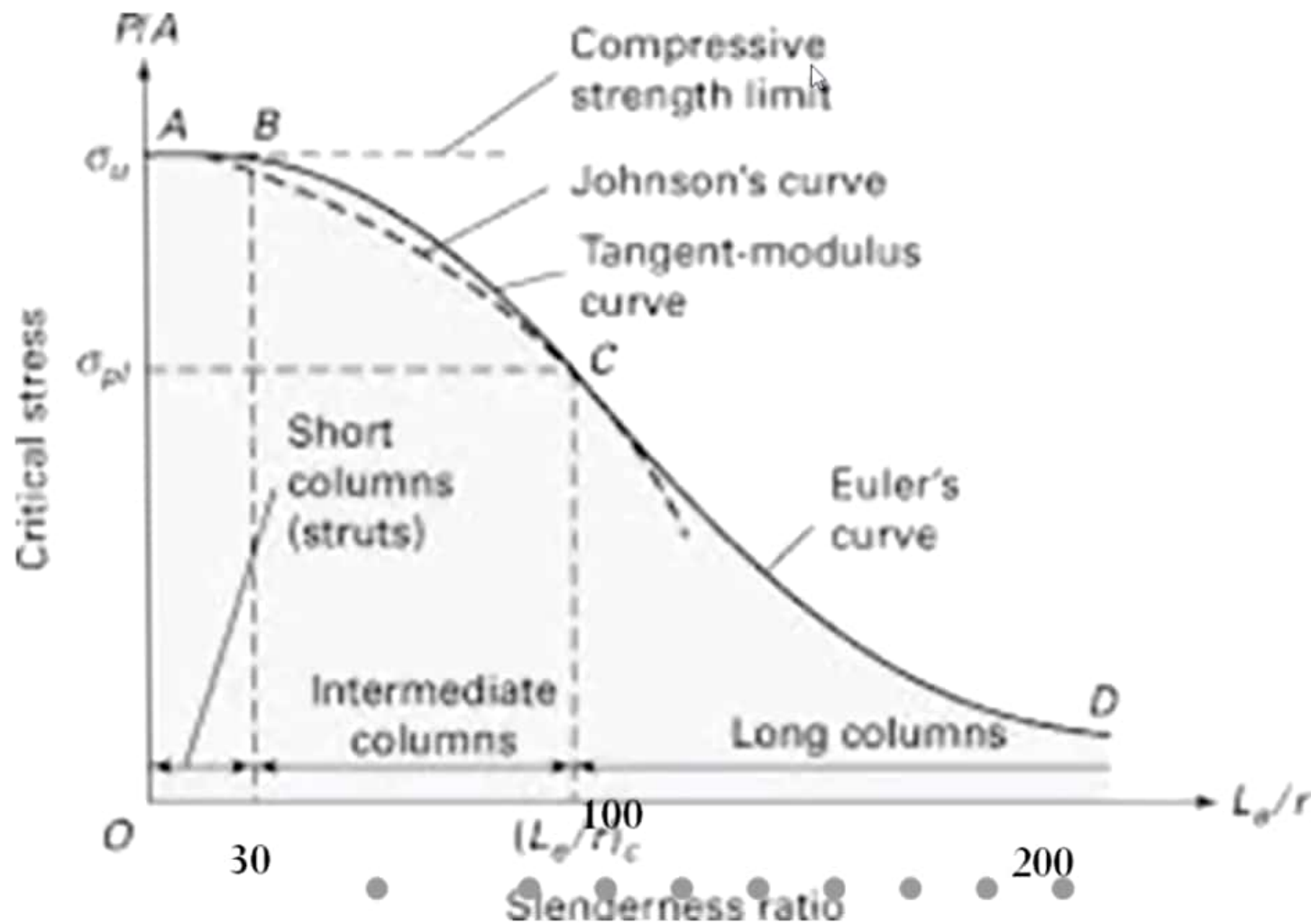

Introduction:

- **Critical Load:** A **critical load** can be interpreted as the maximum axial load to which a column can be subjected and still remain straight, although in such an unstable condition that a slight sideways thrust will cause it to bow out.

Critical Load of Long Columns by **Euler's Formula**:

$$P_{cr} = n^2 \frac{EI\pi^2}{L_e^2}$$

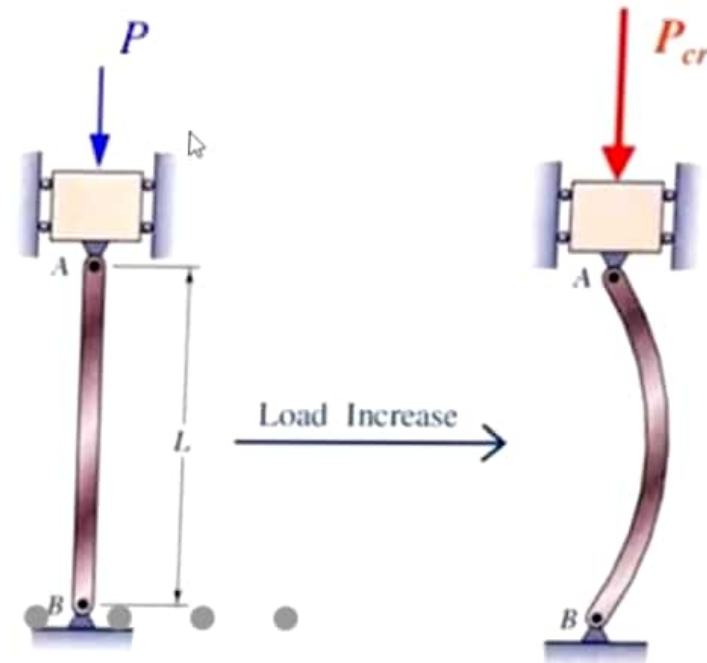

Introduction:

Support Condition:

(a) One fixed end,
one free end

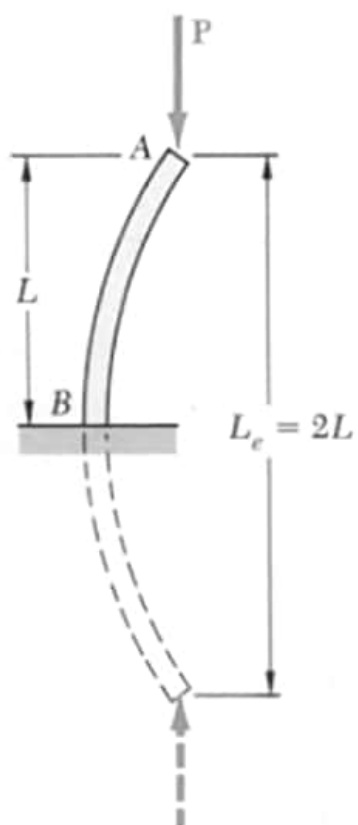

(b) Both ends
pinned

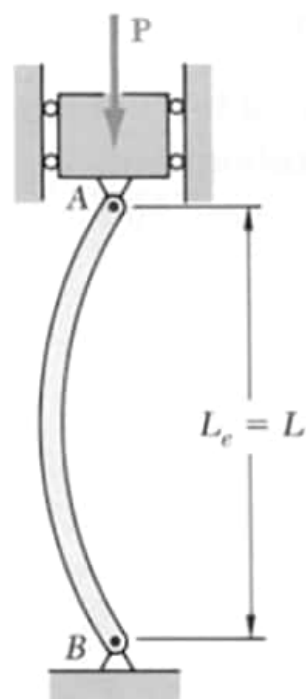

(c) One fixed end,
one pinned end

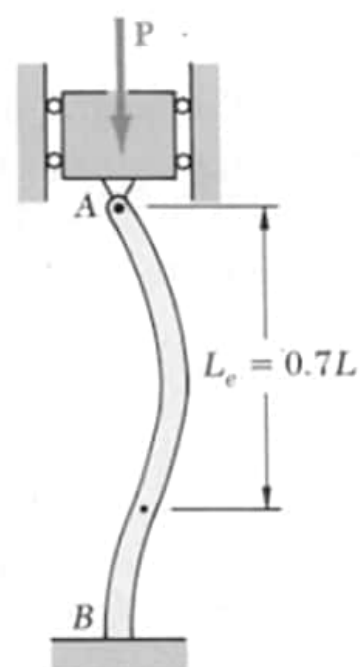

(d) Both ends
fixed

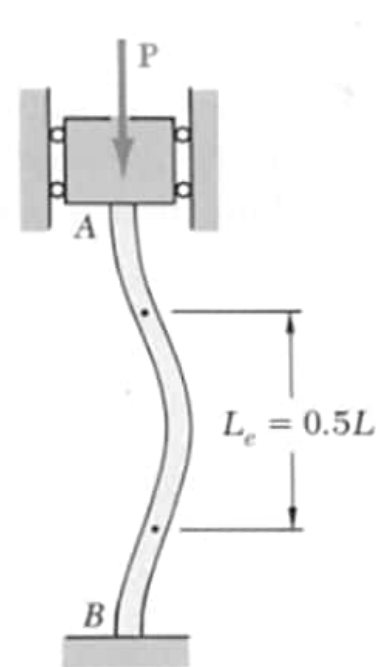

Objectives:

- (i) Determination of the **Critical Load** for different **Support Condition** of Slender Column.
- (ii) Compare the **experimental critical load** with that given by the **Euler's equation**.



Apparatus:

- Buckling Test Machine
- Slide Calipers
- Column
- Scale
- Tape
- Load Equipment



Buckling Test Machine

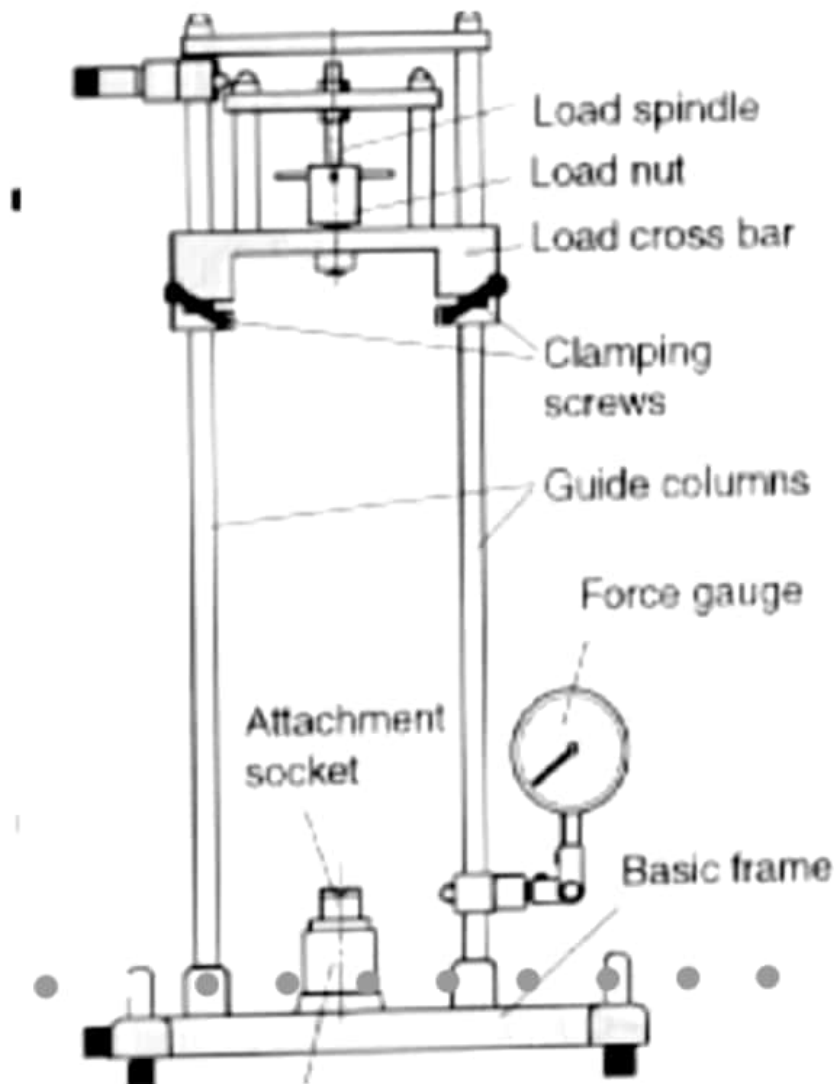

Strut Test
to
Determine
Euler's
Buckling
Load of

Buckling Test Machine



Data Table:

Case	Theoretical Load (kg)	Actual Load (kg)
1) One end fixed and other end hinge		15.82 kg
2) Both end hinged		11.3 kg
3) Both end fixed		27.12 kg

Calculation:

Length of the column $L = 85.5\text{cm}$

Dia of column $D = 1.05\text{cm}$

Data Table

Case No.	Theoretical Load (Kg)	Actual load (Kg)
(i) One end fixed and other hinged		15.82
(ii) Both end hinged		11.3
(iii) Both end fixed		27.12



Results:



Discussions:

- What are possible sources of error?
- Effect of imperfection of the column.
- The effect of slenderness ratio.
- The effect of end condition on the critical loads of the column
- How to improve the testing procedure.
- Limitations of Euler's formula.

