

## Problem 1:

When 1k at point D:

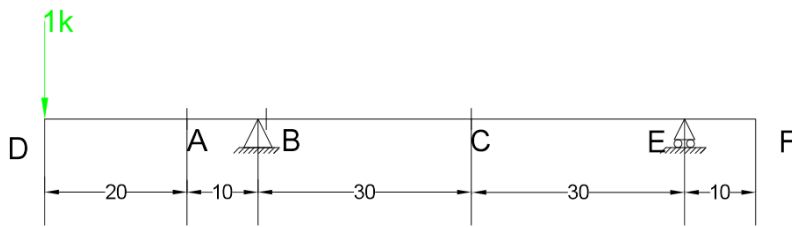

$$R_B = 1.5 k$$

$$R_E = -0.5k$$

$$V_A = -1 k$$

$$V_B = 0.5k$$

$$V_C = 0.5 k$$

$$M_A = -20 k - ft$$

$$M_B = -30 k - ft$$

$$M_C = -15 k - ft$$

When 1k at point A:

$$R_B = 1.167 k$$

$$R_E = -0.167 k$$

$$V_A = -1 k \text{ (when 1k at slight left of A)}$$

$$V_A = 0 k \text{ (when 1k at slight right of A)}$$

$$V_B = 0.167 k$$

$$V_C = 0.167 k$$

$$M_A = 0 k - ft$$

$$M_B = -10 k - ft$$

$$M_C = -5 k - ft$$

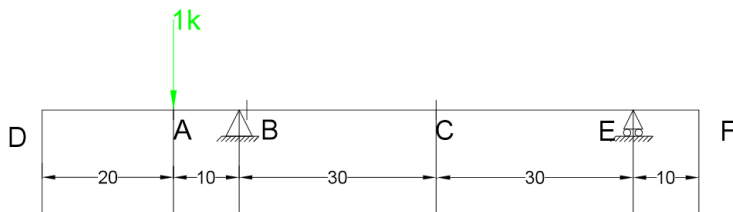

When 1k at point B:

$$R_B = 1 k$$

$$R_E = 0 k$$

$$V_A = 0 k$$

$$V_B = 0 k \text{ (when 1k at slight left of B)}$$

$$V_B = 1 k \text{ (when 1k at slight right of B)}$$

$$V_C = 0 k$$

$$M_A = 0 \text{ k-ft}$$

$$M_B = 0 \text{ k-ft}$$

$$M_C = 0 \text{ k-ft}$$

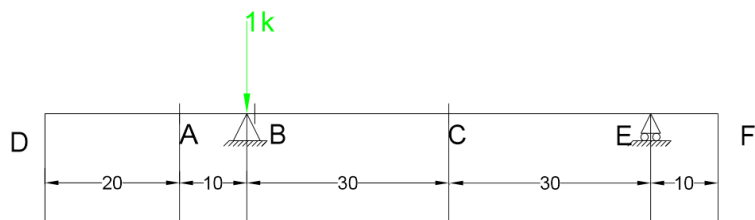

When 1k at point C:

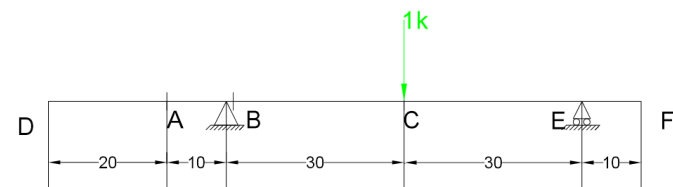

$$R_B = 0.5 \text{ k}$$

$$R_E = 0.5 \text{ k}$$

$$V_A = 0 \text{ k}$$

$$V_B = 0.5 \text{ k}$$

$$V_C = -0.5 \text{ k (when 1k at slight left of C)}$$

$$V_C = 0.5 \text{ k (when 1k at slight right of C)}$$

$$M_A = 0 \text{ k-ft}$$

$$M_B = 0 \text{ k-ft}$$

$$M_C = 15 \text{ k-ft}$$

When 1k at point E:

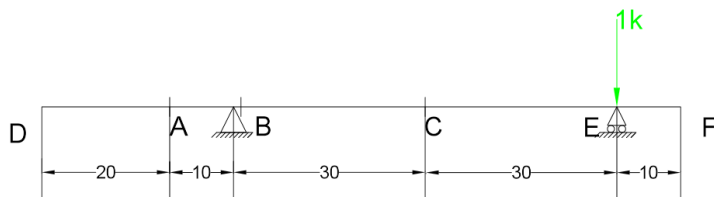

$$R_B = 0 \text{ k}$$

$$R_E = 1 \text{ k}$$

$$V_A = 0 \text{ k}$$

$$V_B = 0 \text{ k}$$

$$V_C = 0 \text{ k}$$

$$M_A = 0 \text{ k-ft}$$

$$M_B = 0 \text{ k-ft}$$

$$M_C = 0 \text{ k-ft}$$

When 1k at point F:

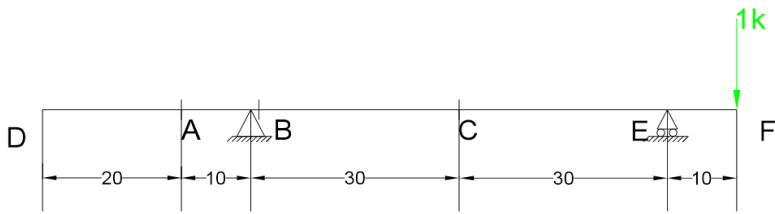

$$R_B = -0.167 k$$

$$R_E = 1.167 k$$

$$V_A = 0 k$$

$$V_B = -0.167 k$$

$$V_C = -0.167 k$$

$$M_A = 0 k - ft$$

$$M_B = 0 k - ft$$

$$M_C = -5 k - ft$$

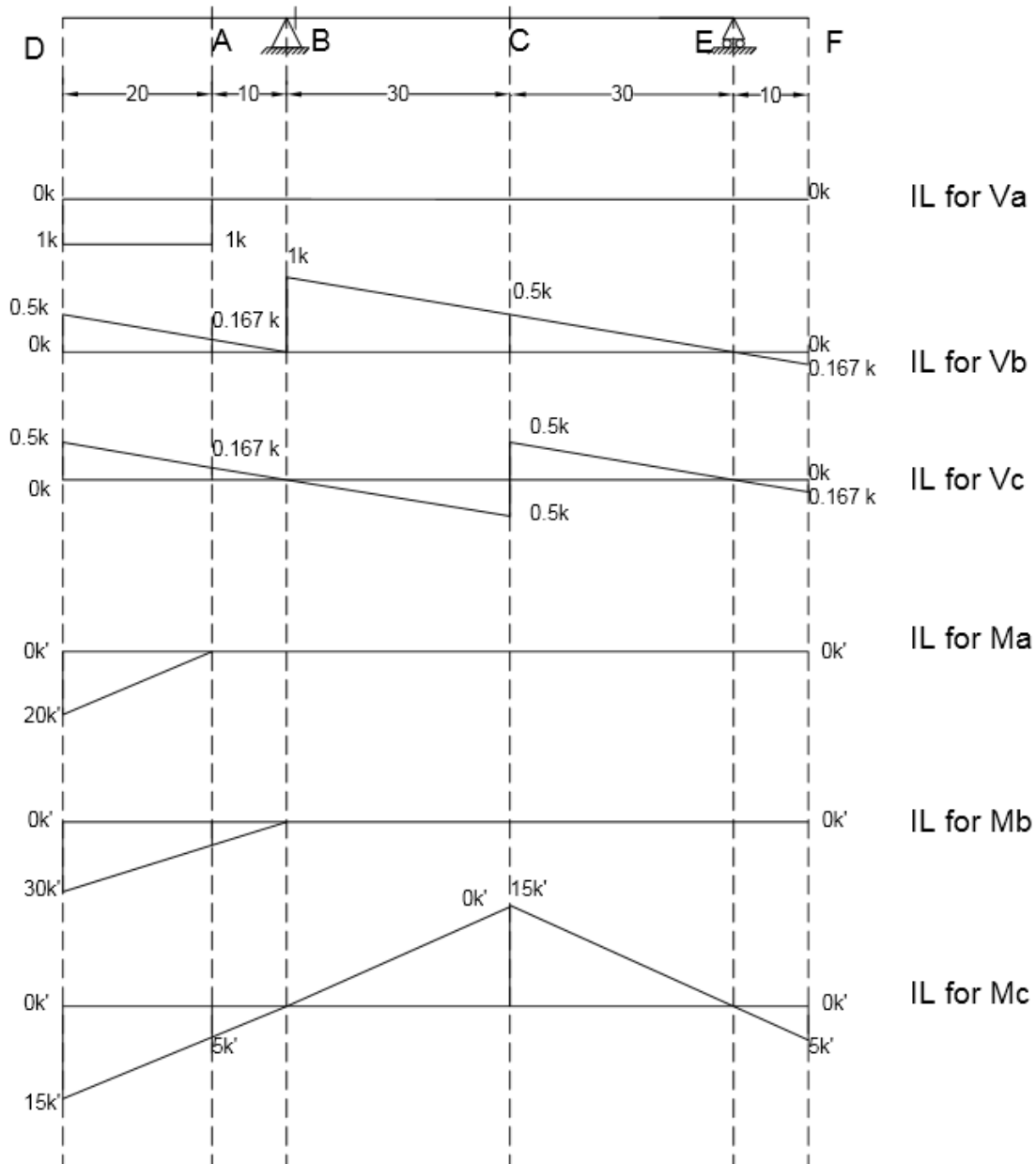



# Problem 2

Draw ILD for shear and moment at a,b & c

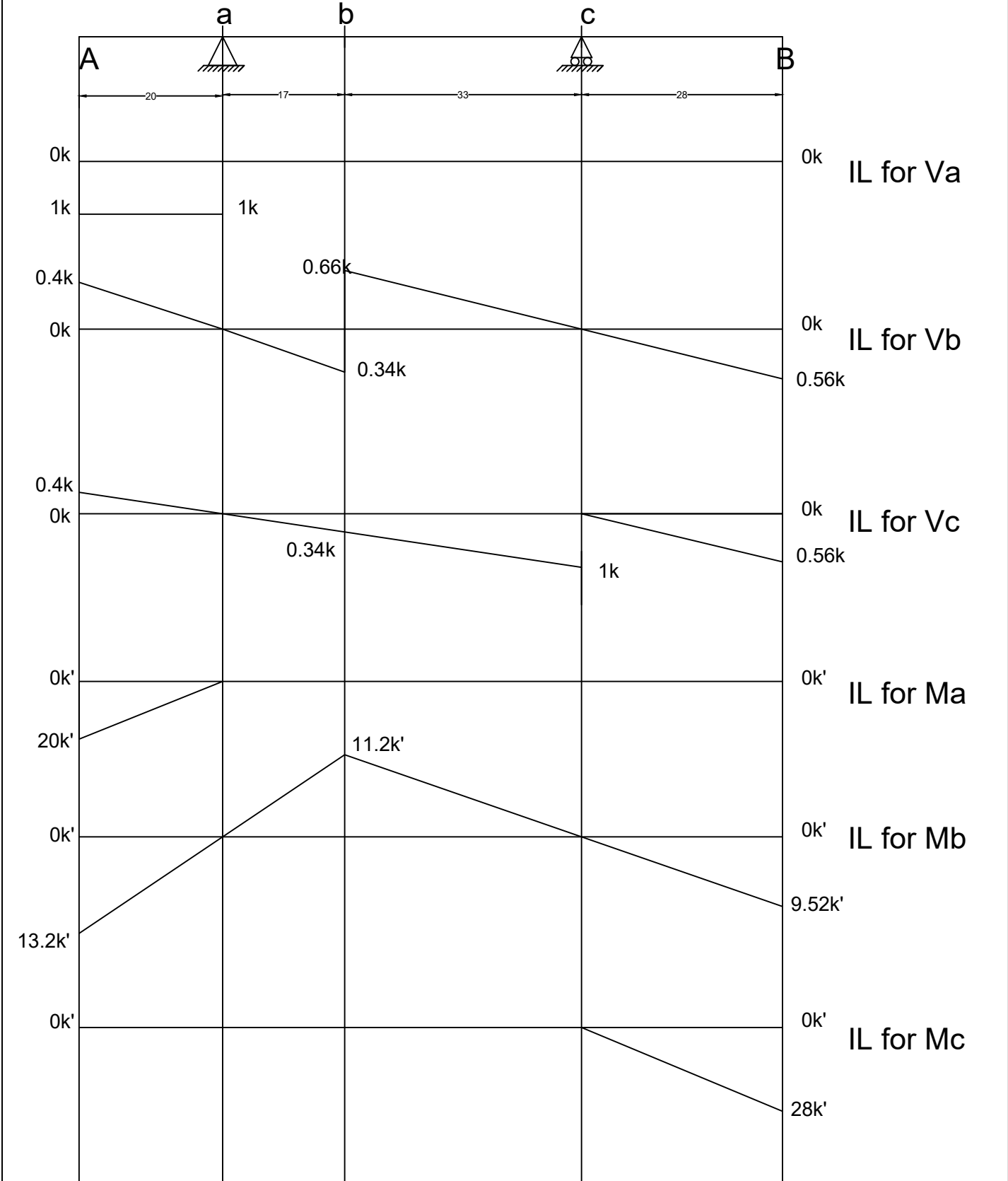

Problem 4  
 Draw ILD for shear and moment at b,c & d

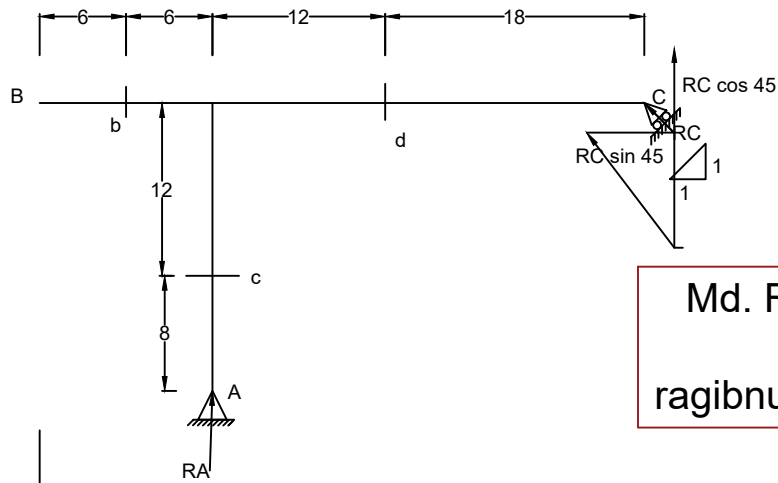

Md. Ragib Nur Alam  
 CE 13  
 ragibnur.ce@gmail.com

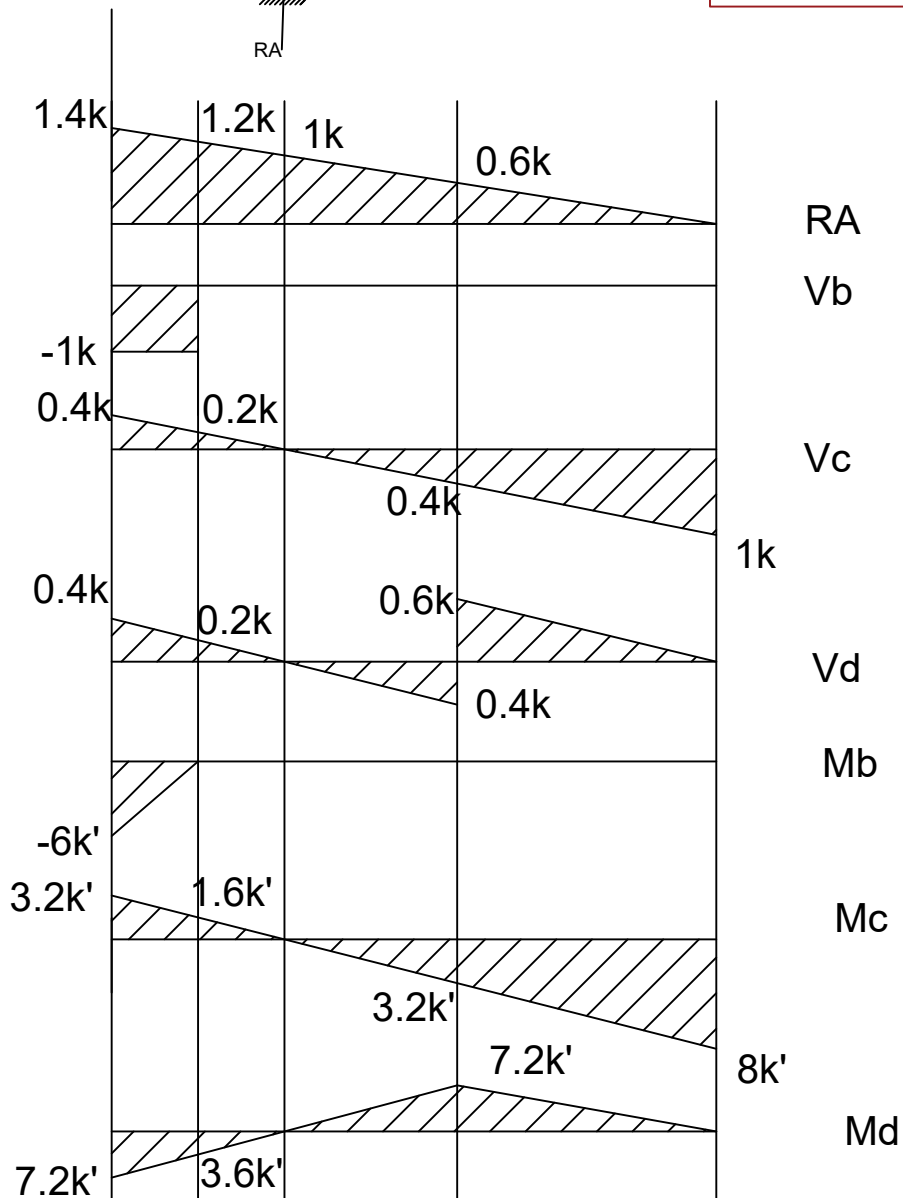

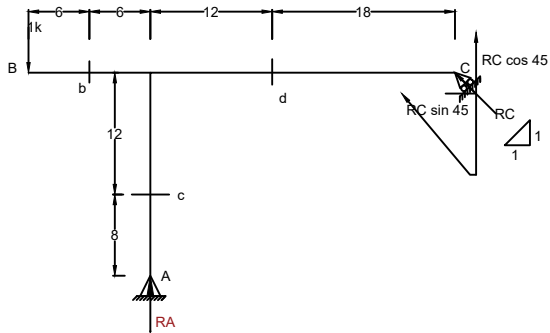

when 1k at B

$$RA = \frac{42}{30} = 1.4k$$

$$RC \cos 45 = -0.4k$$

$$RC = -\frac{0.4}{\cos 45} = -0.566k$$

$$RC \sin 45 = -0.566 \sin 45 = -0.4k$$

$$V_b = -1k$$

$$V_c = -RC \sin 45 = 0.4$$

$$V_d = -RC \cos 45 = 0.4$$

$$M_b = -6k'$$

$$M_c = 3.2k'$$

$$M_d = -7.2k'$$

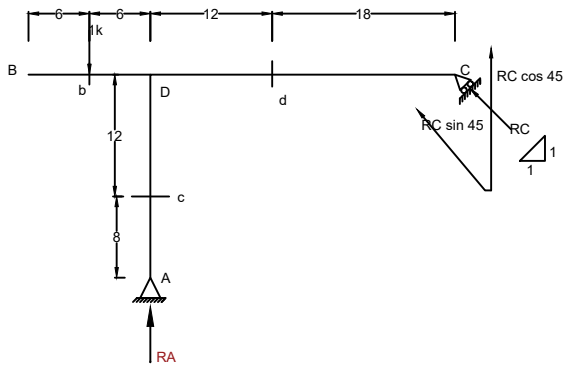
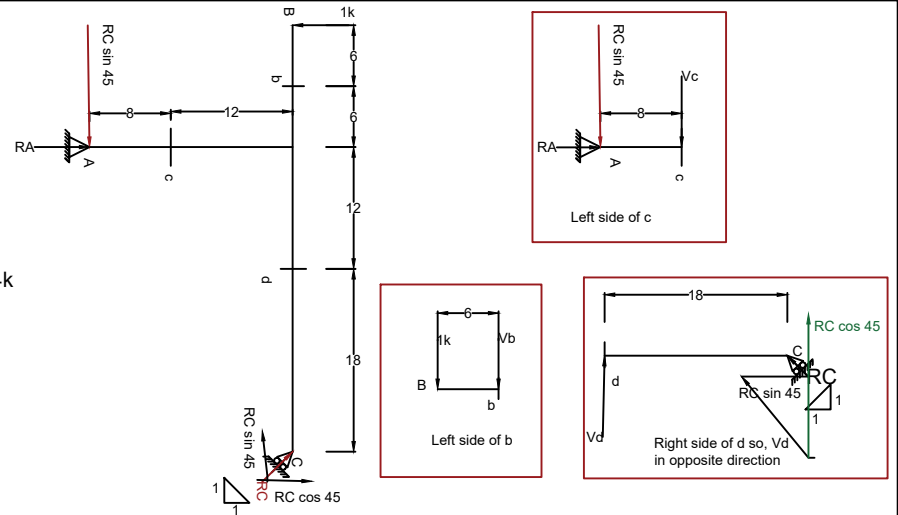

When 1k at b

$$RA = \frac{36}{30} = 1.2k$$

$$RC \cos 45 = -0.2k$$

$$RC = -\frac{0.2}{\cos 45} = -0.283k$$

$$RC \sin 45 = -0.283 \sin 45 = -0.2k$$

$$V_b = -1k(\text{left})$$

$$V_b = 0(\text{right})$$

$$V_c = -RC \sin 45 = 0.2$$

$$V_d = -RC \cos 45 = 0.2$$

$$M_b = 0k'$$

$$M_c = 1.6k'$$

$$M_d = -3.6k'$$

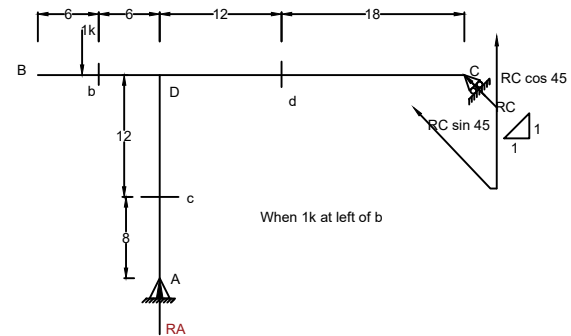

When 1k at left of b

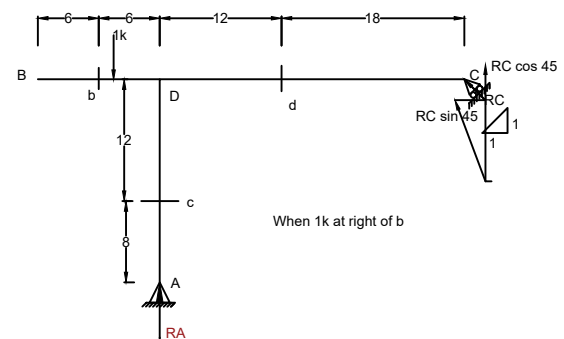

When 1k at right of b

Md. Ragib Nur Alam  
CE 13  
ragibnur.ce@gmail.com

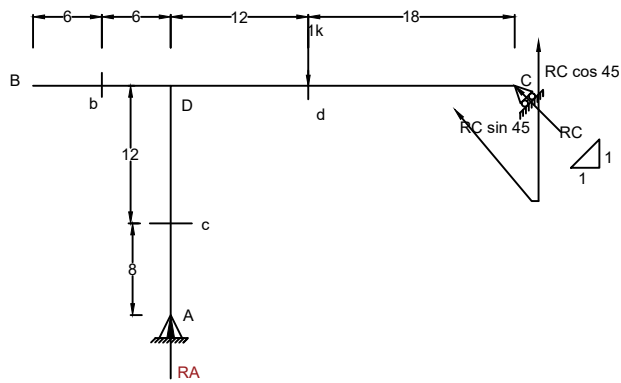

When 1k at d  
 $RA = \frac{18}{30} = 0.6k$   
 $RC \cos 45 = 0.4k$   
 $RC = \frac{0.4}{\cos 45} = 0.566k$   
 $RC \sin 45 = 0.566 \sin 45 = 0.4k$   
 $V_b = 0k$   
 $V_c = -RC \sin 45 = -0.4k$   
 $V_d = -RC \cos 45 = -0.4k$  (left)  
 $V_d = -RC \cos 45 = -0.6k$  (right)  
 $M_b = 0k'$   
 $M_c = -3.2k'$   
 $M_d = 7.2k'$

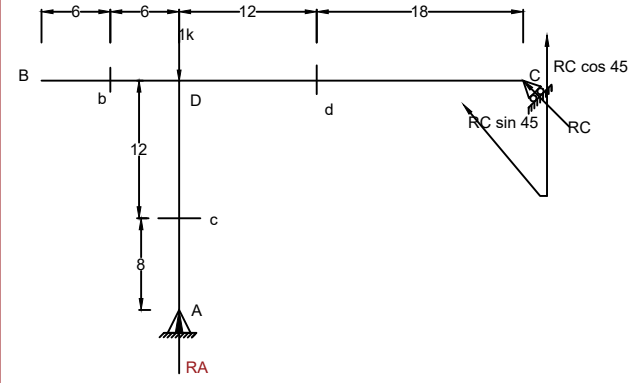

When 1k at D  
 $RA = 1k$   
 $RC \cos 45 = 0k$   
 $RC = \frac{0.2}{\cos 45} = 0k$   
 $RC \sin 45 = -0.283 \sin 45 = 0k$   
 $V_b = 0k$   
 $V_c = -RC \sin 45 = 0$   
 $V_d = -RC \cos 45 = 0$   
 $M_b = 0k'$   
 $M_c = 0k'$   
 $M_d = 0k'$

Md. Ragib Nur Alam  
 CE 13  
 ragibnur.ce@gmail.com

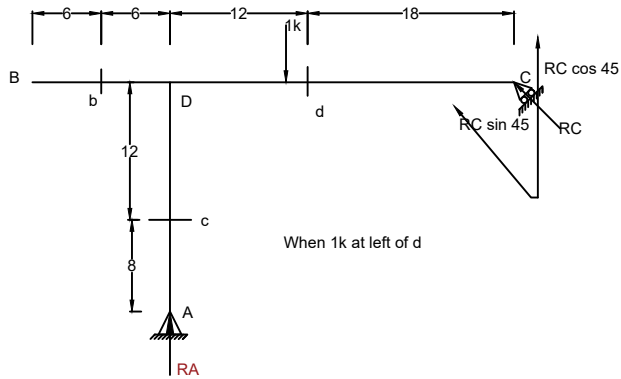

When 1k at left of d

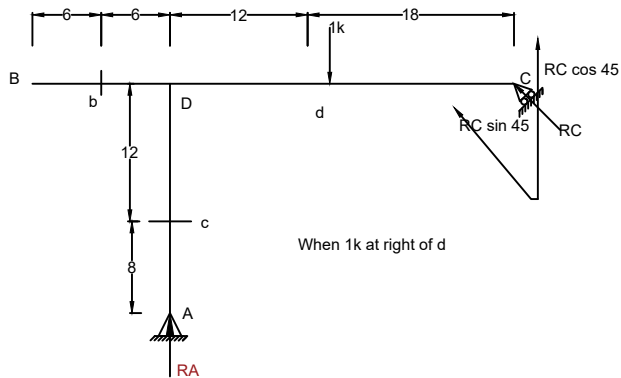

When 1k at right of d

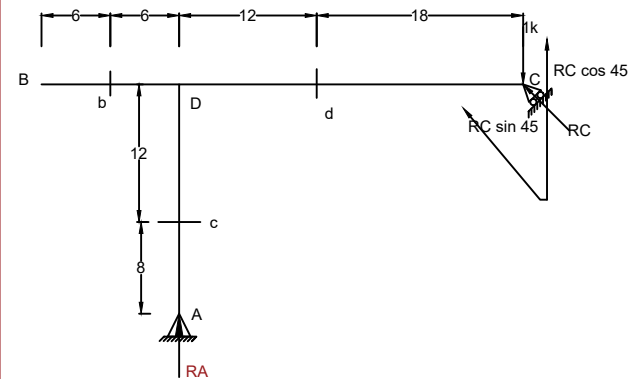

When 1k at C  
 $RA = 0k$   
 $RC \cos 45 = 1k$   
 $RC = \frac{1}{\cos 45} = 1.414k$   
 $RC \sin 45 = 1.414 \sin 45 = 1k$   
 $V_b = 0k$   
 $V_c = -RC \sin 45 = -1k$   
 $V_d = 0k$   
 $M_b = 0k'$   
 $M_c = -8k'$   
 $M_d = 0k'$



**Problem 06**

Find shear and moment at 1,2 &3 and reaction at C if load moves from B to D

Shear force is sum of all the transverse forces  
(perpendicular to the member or beam)

Md. Ragib Nur Alam  
CE 13  
ragibnur.ce@gmail.com

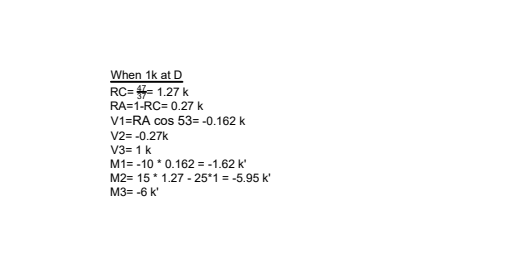
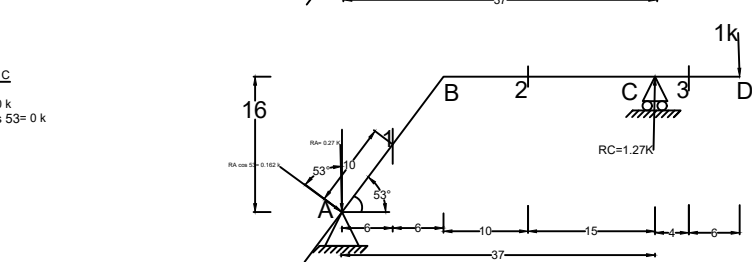
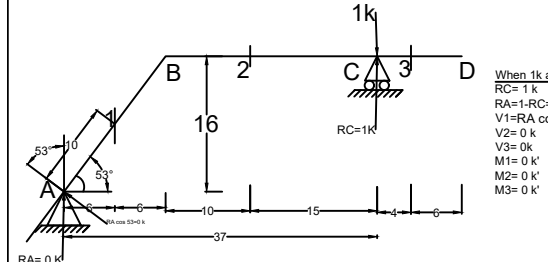
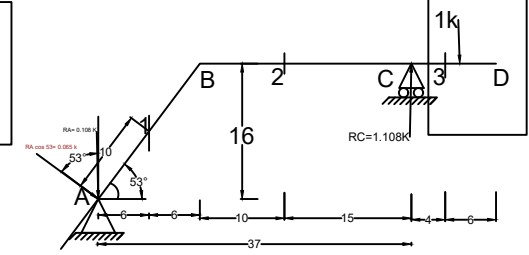
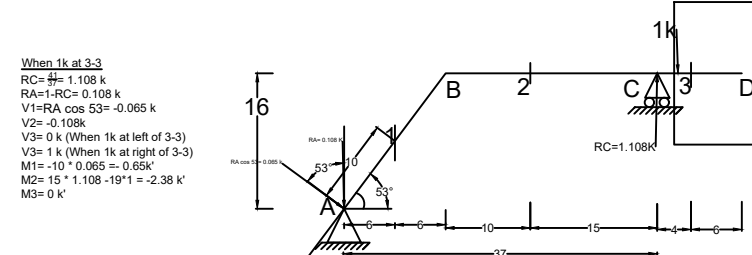
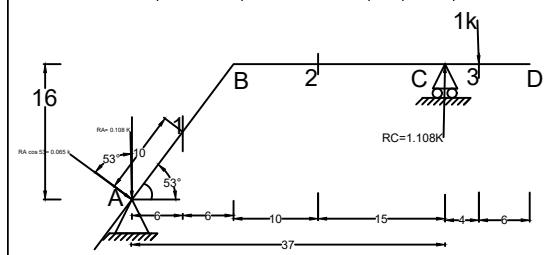
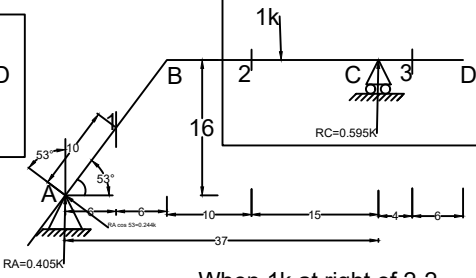
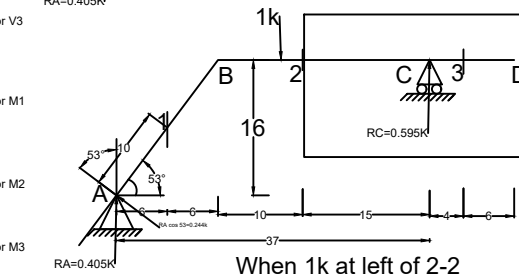
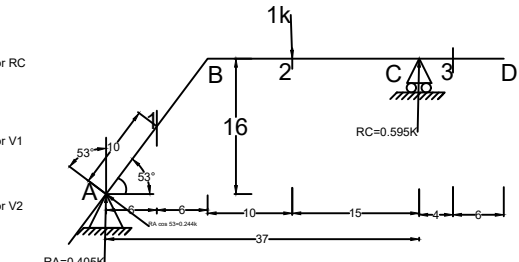
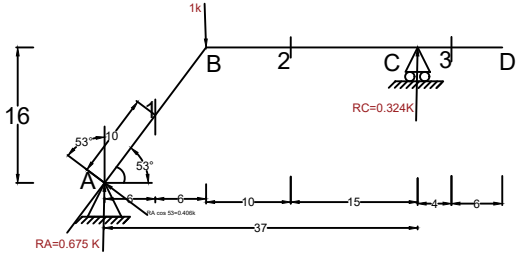
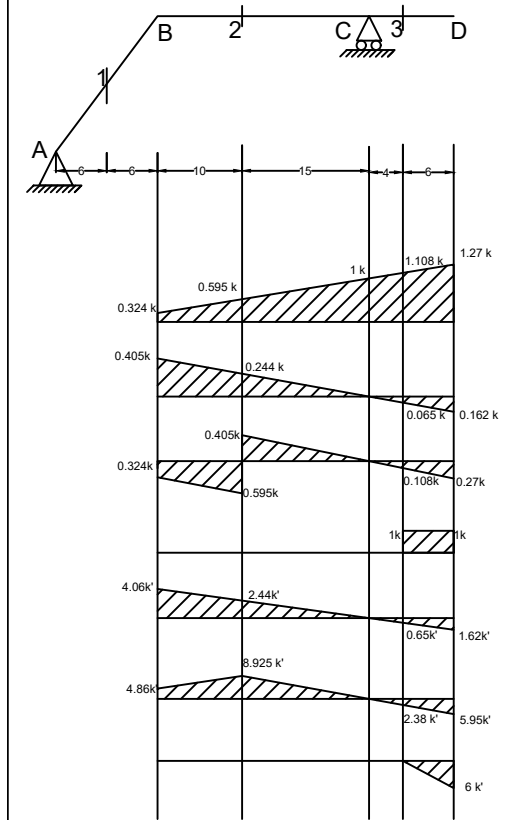

Problem 7

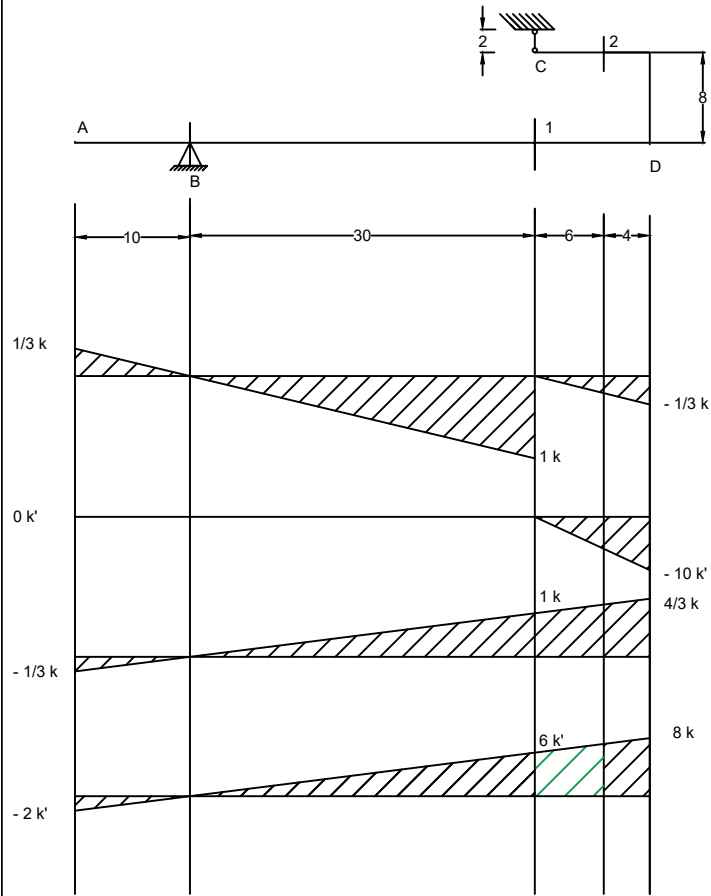

Md. Ragib Nur Alam  
CE 13  
ragibnur.ce@gmail.com

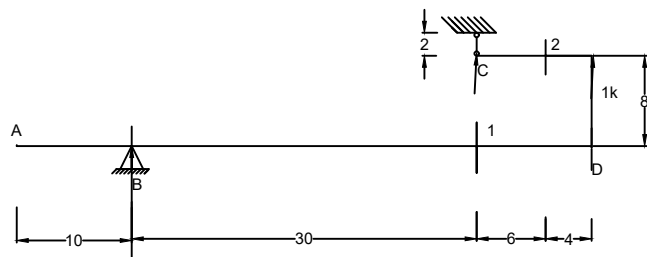

When 1k at D  
 $R_c = \frac{2}{3} k$   $R_b = -\frac{1}{3} k$   
 $V_1 = -\frac{1}{3} k$   
 $M_1 = -10 k$   
 $V_2 = \frac{2}{3} k$   
 $M_2 = 8 k'$

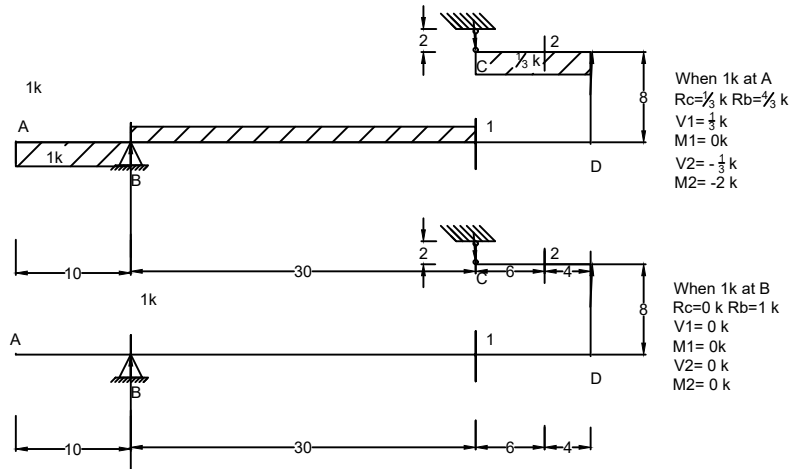

When 1k at A  
 $R_c = \frac{1}{3} k$   $R_b = \frac{2}{3} k$   
 $V_1 = \frac{1}{3} k$   
 $M_1 = 0 k$   
 $V_2 = -\frac{1}{3} k$   
 $M_2 = -2 k$

Left clockwise moment +ve  
up shear +ve

When 1k at B  
 $R_c = 0 k$   $R_b = 1 k$   
 $V_1 = 0 k$   
 $M_1 = 0 k$   
 $V_2 = 0 k$   
 $M_2 = 0 k$

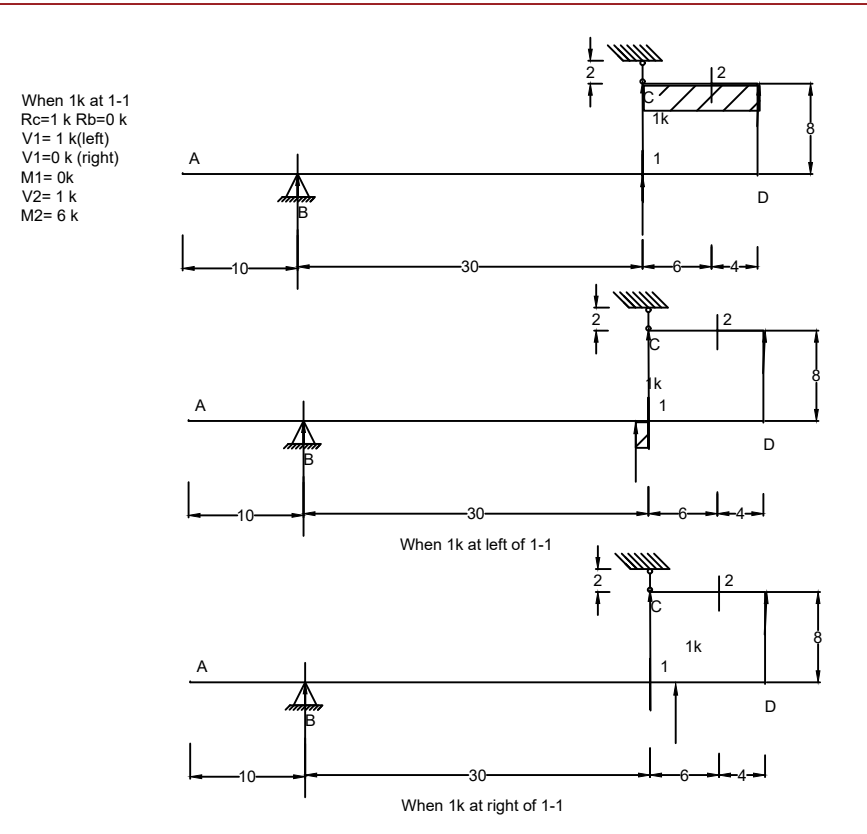

When 1k at 1-1  
 $R_c = 1 k$   $R_b = 0 k$   
 $V_1 = 1 k$  (left)  
 $V_1 = 0 k$  (right)  
 $M_1 = 0 k$   
 $V_2 = 1 k$   
 $M_2 = 6 k$

When 1k at left of 1-1

When 1k at right of 1-1

**Problem 08**

Draw ILD for shear and moment for f & g for the unit load moving from A to B.

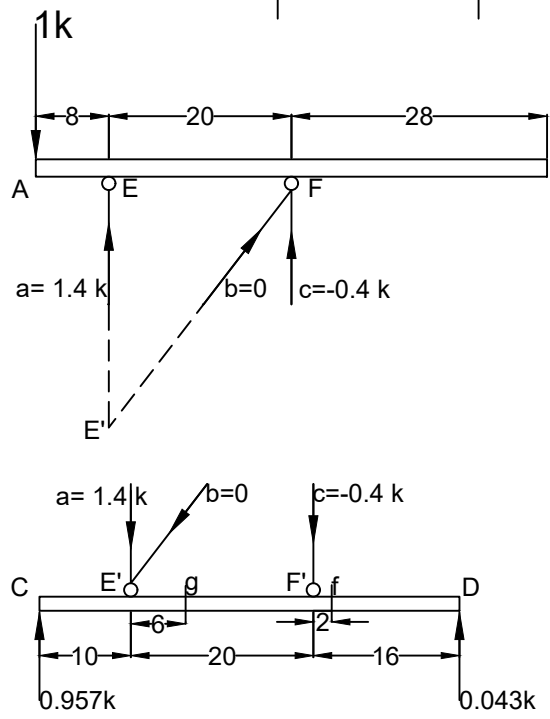
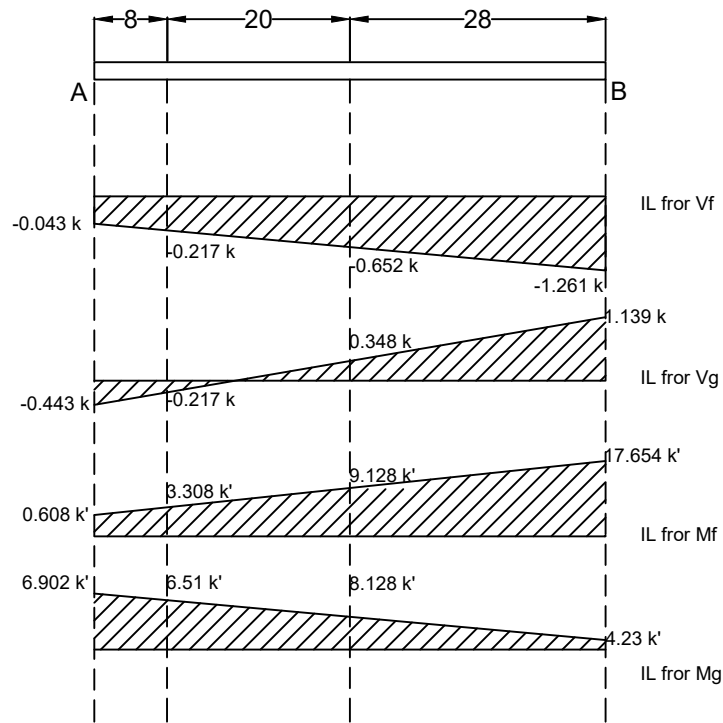
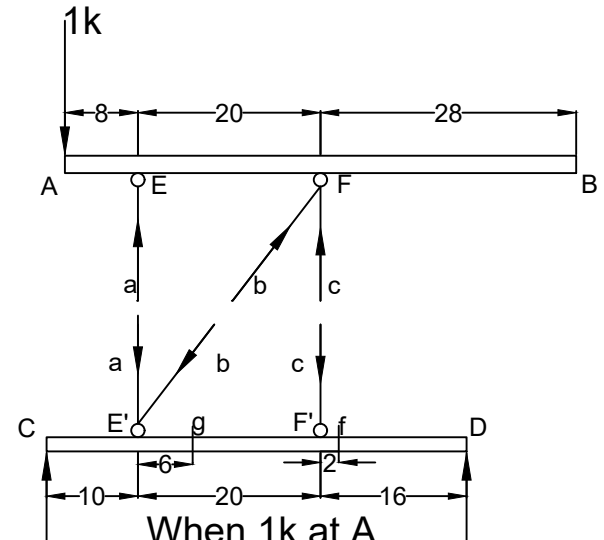
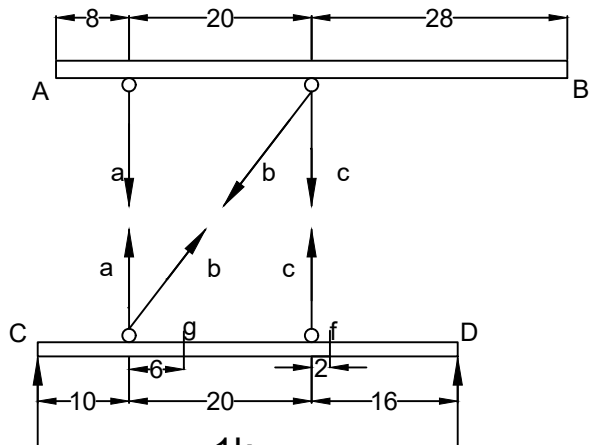
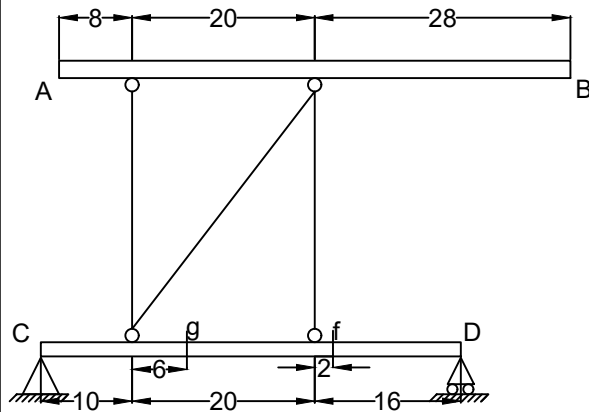

**When 1k at A**

Take moment about F  $\sum ME' = 0$   
 so, unknown reduced to 1  $\Rightarrow -1 \cdot 8 - c \cdot 20 = 0$   
 $\Rightarrow c = -0.4 \text{ k}$

sum of moments at  $\sum MF = 0$   
 $\Rightarrow -1 \cdot 28 + a \cdot 20 = 0$   
 $\Rightarrow a = \frac{28}{20} = 1.4 \text{ k}$

$\sum Fy = 0$   
 $\Rightarrow a + c + by - 1 = 0$   
 $\Rightarrow 1.4 - 0.4 + by - 1 = 0$   
 $\Rightarrow by = 0$

Then take moment about E'  
 a and b passes through E'

$\sum Fx = 0$   
 $\Rightarrow bx = 0$

Take moment about C  $\sum MC = 0$   
 $\Rightarrow 1.4 \cdot 10 - 0.4 \cdot 30 - RD \cdot 46 = 0$   
 $\Rightarrow RD = \frac{2}{46} = 0.0434 \text{ k}$

$\sum Fy = 0$   
 $\Rightarrow 1.4 - 0.4 - 0.043 - RC = 0$   
 $\Rightarrow RC = 0.957 \text{ k}$

$V_f = -0.0434 \text{ k}$   
 $V_g = -0.0434 - 0.4 = -0.4434 \text{ k}$

$M_f = 0.0434 \cdot 14 = 0.6076 \text{ k'}$   
 $M_g = 0.0434 \cdot 30 + 0.4 \cdot 14 = 6.902 \text{ k'}$

### When 1k at E

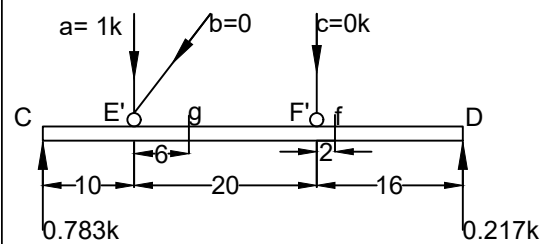
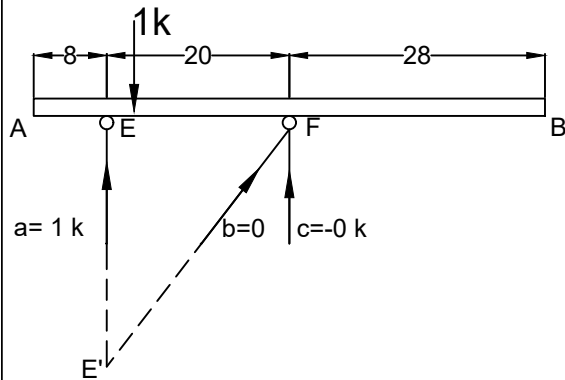

Take moment about F.  
so, unknown reduced to 1. sum of moments at

$$\sum MF = 0$$

$$\Rightarrow -1 \cdot 20 + a \cdot 20 = 0$$

$$\Rightarrow a = 1k$$

Then take moment about E'. since, a and b passes through E'

$$\sum ME' = 0$$

$$\Rightarrow c = 0$$

$$\sum Fy = 0$$

$$\Rightarrow by = 0$$

$$\sum Fx = 0$$

$$\Rightarrow bx = 0$$

Take moment about C  
 $\sum MC = 0$   
 $\Rightarrow 1 \cdot 10 - RD \cdot 46 = 0$   
 $\Rightarrow RD = \frac{10}{46} = 0.217k$

$$\sum Fy = 0$$

$$\Rightarrow 1 - 0.217 - RC = 0$$

$$\Rightarrow RC = 0.783k$$

$$Vf = -0.217k$$

$$Vg = -0.217k$$

$$Mf = 0.217 \cdot 14 = 3.038k'$$

$$Mg = 0.217 \cdot 30 = 6.51k'$$

### When 1k at F

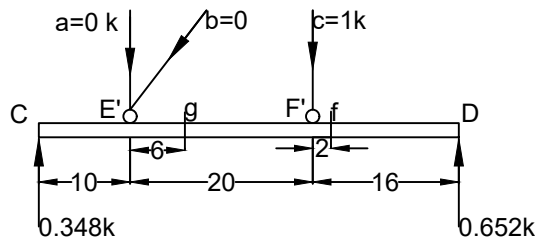
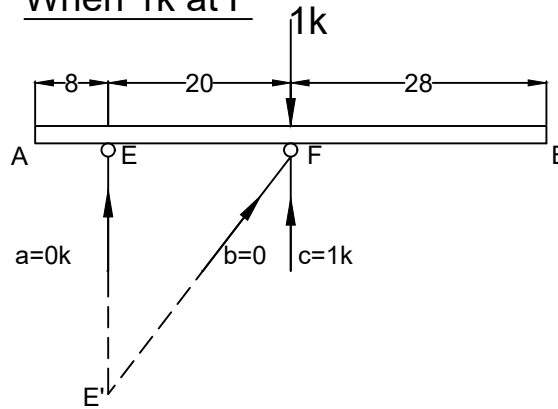

Take moment about F.  
so, unknown reduced to 1. sum of moments at F

Then take moment about E' a and b passes through E'

$$\sum ME' = 0$$

$$\Rightarrow -1 \cdot 20 + c \cdot 20 = 0$$

$$\Rightarrow c = 1k$$

$$\sum Fy = 0$$

$$\Rightarrow by = 0$$

$$\sum Fx = 0$$

$$\Rightarrow bx = 0$$

Take moment about C  
 $\sum MC = 0$   
 $\Rightarrow 1.4 \cdot 10 - 0.4 \cdot 30 - RD \cdot 46 = 0$   
 $\Rightarrow RD = \frac{30}{46} = 0.652k$

$$\sum Fy = 0$$

$$\Rightarrow 1 - 0.652 - RC = 0$$

$$\Rightarrow RC = 0.348k$$

$$Vf = -0.652k$$

$$Vg = 1 - 0.652 = 0.348k$$

$$Mf = 0.348 \cdot 14 = 4.872k'$$

$$Mg = 0.652 \cdot 30 - 1 \cdot 14 = 9.56k'$$

### When 1k at B

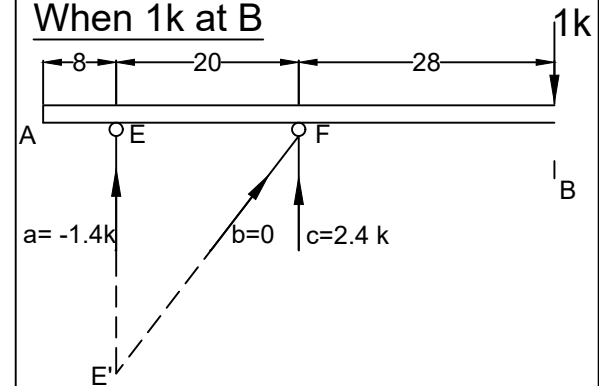

Take moment about F

so, unknown reduced to 1. sum of moments at F

$$\sum ME' = 0$$

$$\Rightarrow 1 \cdot 48 - c \cdot 20 = 0$$

$$\Rightarrow c = 2.4k$$

Then take moment about E' . a and b passes through E'

$$\sum MF = 0$$

$$\Rightarrow a \cdot 20 + 1 \cdot 28 = 0$$

$$\Rightarrow a = -1.4k$$

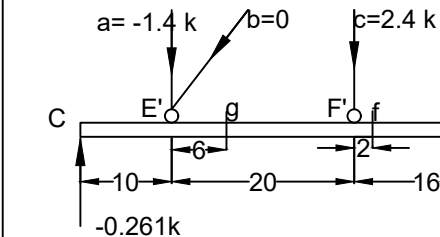

Take moment about C

$$\sum MC = 0$$

$$\Rightarrow -1.4 \cdot 10 + 2.4 \cdot 30 - RD \cdot 46 = 0$$

$$\Rightarrow RD = \frac{58}{46} = 1.261k$$

$$\sum Fy = 0$$

$$\Rightarrow -1.4 + 2.4 - 1.261 - RC = 0$$

$$\Rightarrow RC = -0.261k$$

$$Vf = -1.261k$$

$$Vg = -1.261 + 2.4 = 1.139k$$

$$Mf = 1.261 \cdot 14 = 17.654k'$$

$$Mg = 1.261 \cdot 30 - 2.4 \cdot 14 = 4.23k'$$

**Problem 09**

Draw ILD for RA, RBC, shear & moment at 1-1 & 2-2

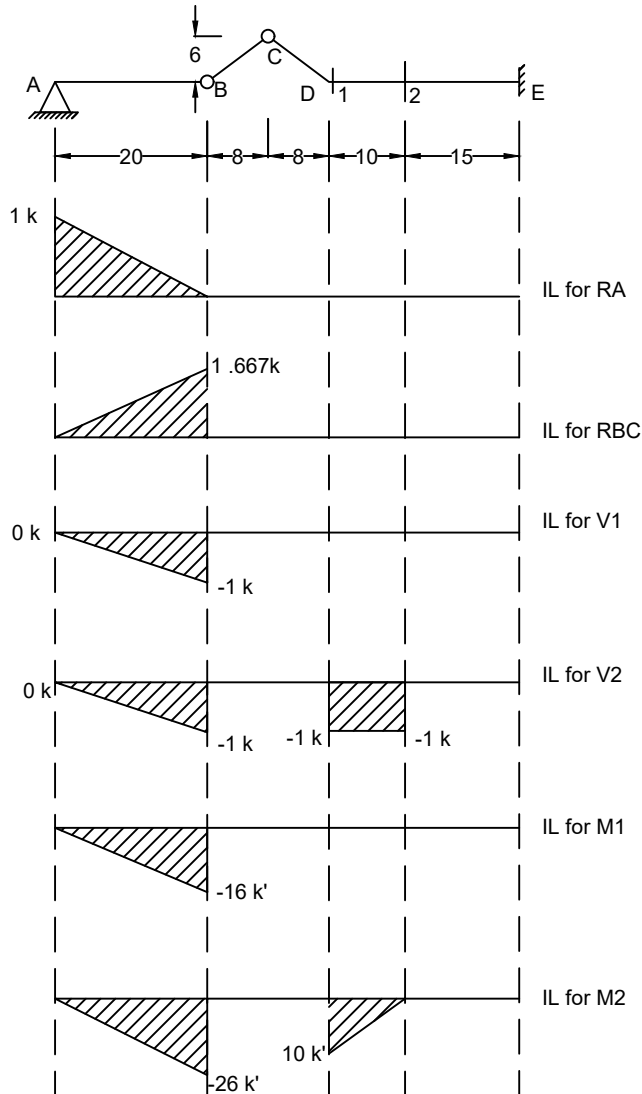

**When 1 k at A**

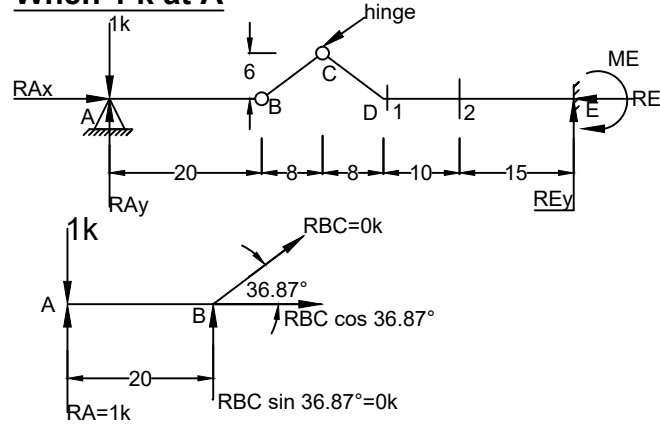

$$\begin{aligned} \sum M_B &= 0 \\ \Rightarrow RA &= 1k \\ \sum F_y &= 0 \\ \Rightarrow RBC \sin 36.87^\circ &= 0k \\ \Rightarrow RBC &= \frac{0}{\sin 36.87^\circ} = 0k \\ \Rightarrow RBC \cos 36.87^\circ &= 0k \end{aligned}$$

$$\begin{aligned} V1 &= 0k \\ V2 &= 0k \end{aligned}$$

$$\begin{aligned} M1 &= 0k' \\ M2 &= 0k' \end{aligned}$$

**When 1 k at B**

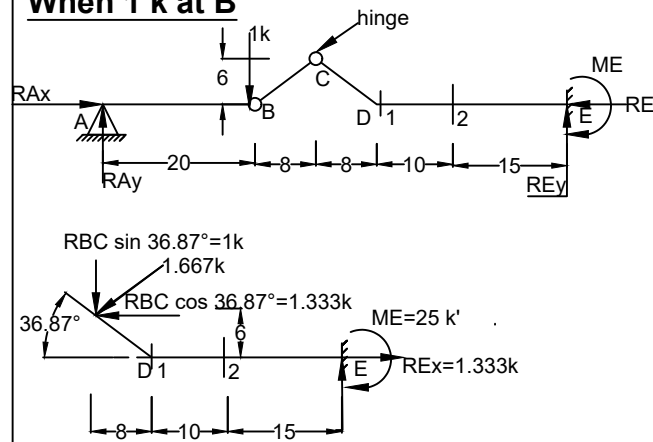

$$\begin{aligned} \sum M_B &= 0 \\ \Rightarrow RA &= 0k \\ \sum F_y &= 0 \\ \Rightarrow RBC \sin 36.87^\circ &= 1k \\ \Rightarrow RBC &= \frac{1}{\sin 36.87^\circ} = 1.667k \\ \Rightarrow RBC \cos 36.87^\circ &= 1.333k \\ ME &= 33 \cdot 1 + 1.333 \cdot 6 = 41k' \end{aligned}$$

$$\begin{aligned} V1 &= -1k \\ V2 &= -1k \end{aligned}$$

$$\begin{aligned} M1 &= -41 + 25 = -16k' \\ M2 &= -25 + 15 = -26k' \end{aligned}$$

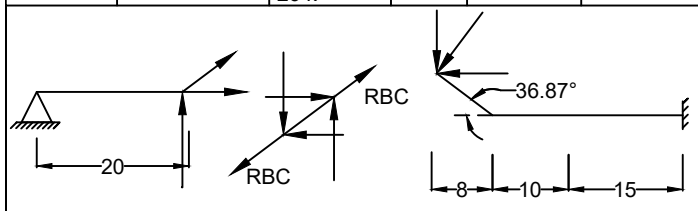
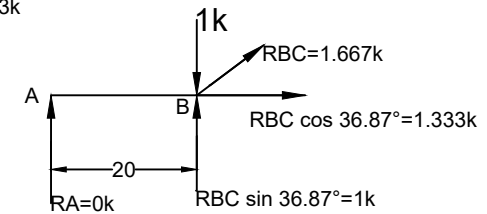

### When 1 k at D

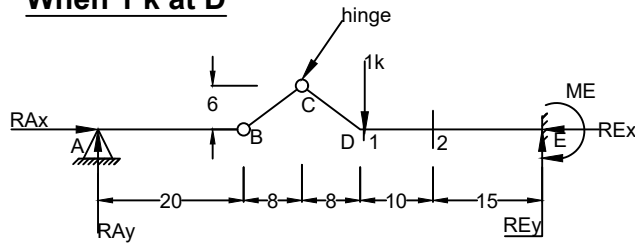

$$\begin{aligned} \sum MB &= 0 \\ \Rightarrow RA &= 0k \\ \sum Fy &= 0 \\ \Rightarrow RBC \sin 36.87^\circ &= 0k \\ \Rightarrow RBC &= \frac{0}{\sin 36.87^\circ} = 0k \\ \Rightarrow RBC \cos 36.87^\circ &= 0k \\ ME &= -25 * 1 = -25k' \end{aligned}$$

$$\begin{aligned} V1 &= -1k \text{ (Just left of section 1-1)} \\ V1 &= 0k \text{ (Just right of section 1-1)} \\ V2 &= -1k \\ M1 &= -25 + 25 = 0k' \\ M2 &= -25 + 15 = -10k' \end{aligned}$$

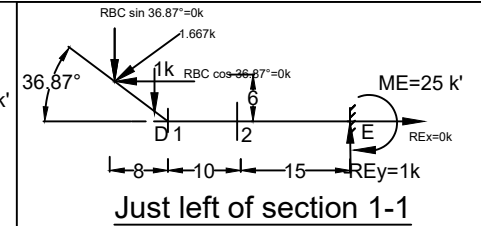
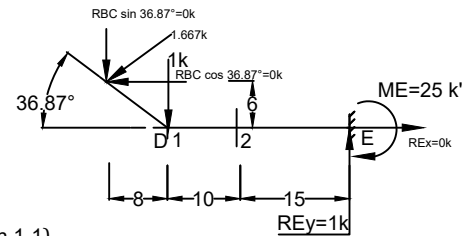

Just left of section 1-1

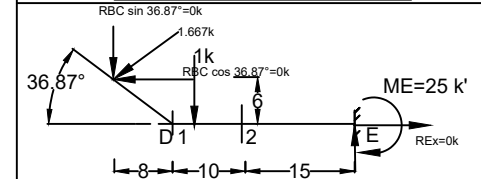

Just right of section 1-1

### When 1 k at 2-2

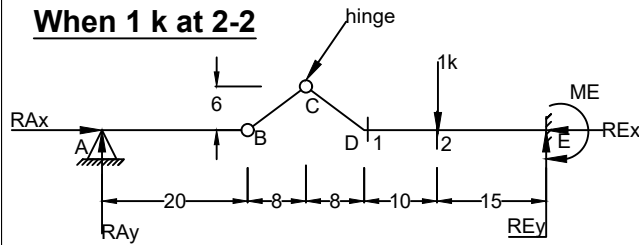

$$\begin{aligned} \sum MB &= 0 \\ \Rightarrow RA &= 0k \\ \sum Fy &= 0 \\ \Rightarrow RBC \sin 36.87^\circ &= 0k \\ \Rightarrow RBC &= \frac{0}{\sin 36.87^\circ} = 0k \\ \Rightarrow RBC \cos 36.87^\circ &= 0k \\ ME &= -15 * 1 = -15k' \end{aligned}$$

$$\begin{aligned} V1 &= 0k \\ V2 &= -1k \text{ (Just left of section 2-2)} \\ V2 &= 0k \text{ (Just right of section 2-2)} \\ M1 &= -15 - 10 + 25 = 0k' \\ M2 &= -15 + 15 = 0k' \end{aligned}$$

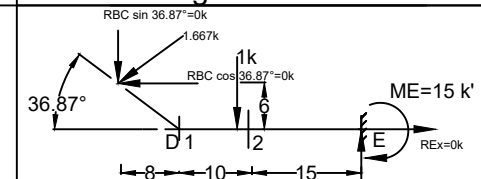
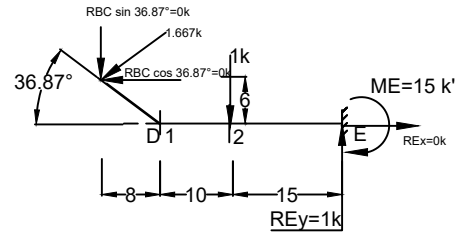

Just left of section 2-2

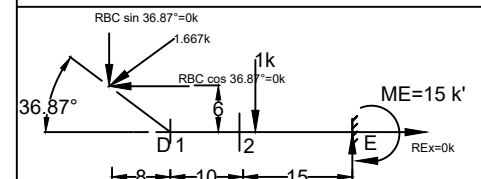

Just right of section 2-2

### When 1 k at E

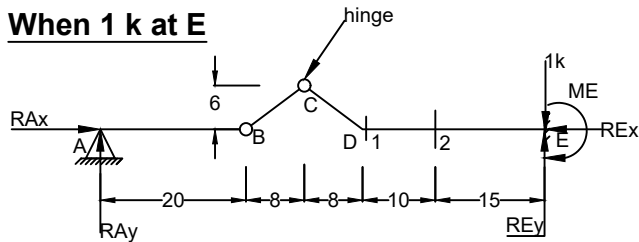

$$\begin{aligned} \sum MB &= 0 \\ \Rightarrow RA &= 0k \\ \sum Fy &= 0 \\ \Rightarrow RBC \sin 36.87^\circ &= 0k \\ \Rightarrow RBC &= \frac{0}{\sin 36.87^\circ} = 0k \\ \Rightarrow RBC \cos 36.87^\circ &= 0k \\ ME &= 0k' \end{aligned}$$

$$\begin{aligned} V1 &= 0k \\ V2 &= 0k \\ M1 &= -25 + 25 = 0k' \\ M2 &= -15 + 15 = 0k' \end{aligned}$$

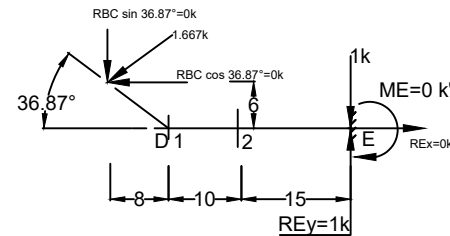

Created By -  
Md.Ragib Nur Alam(CE- 13)  
ragibnur.ce@gmail.com

# Problem 10

Draw ILD for RBE, shear & moment at F & G

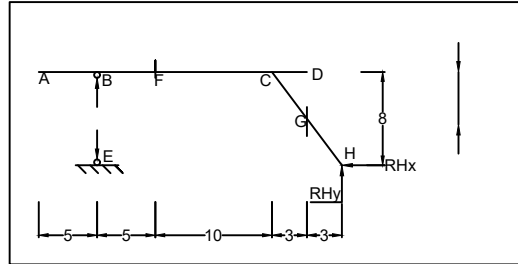
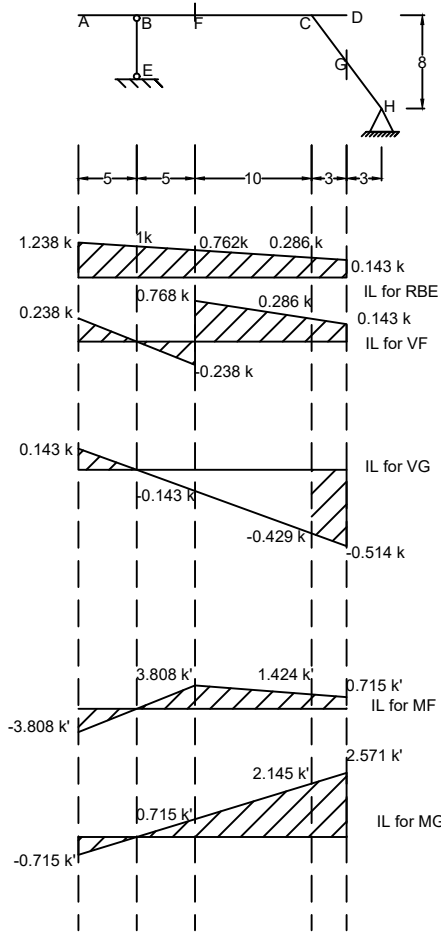

## When 1 k at A

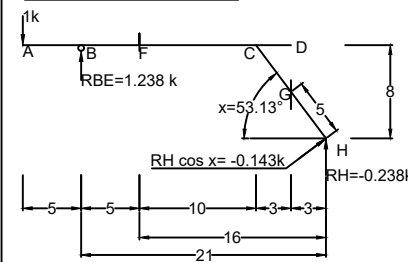

$$\begin{aligned} \sum M_H &= 0 \\ \Rightarrow RBE \cdot 21 - 26 \cdot 1 &= 0 \\ \Rightarrow RBE &= 1.238 \text{ k} \\ \sum F_y &= 0 \\ \Rightarrow RH &= -0.238 \text{ k} \\ \Rightarrow RH \cos 53.13^\circ &= -0.143 \text{ k} \\ VF &= 1.238 - 1 = 0.238 \text{ k} \\ VG &= 0.143 \text{ k} \\ MF &= -0.238 \cdot 16 = -3.808 \text{ k}' \\ MG &= -0.143 \cdot 5 = -0.715 \text{ k}' \end{aligned}$$

## When 1 k at B

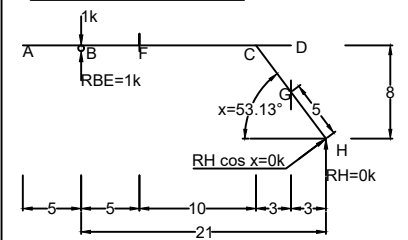

$$\begin{aligned} \sum M_H &= 0 \\ \Rightarrow RBE \cdot 21 - 21 \cdot 1 &= 0 \\ \Rightarrow RBE &= 0 \text{ k} \\ \sum F_y &= 0 \\ \Rightarrow RH &= 0 \text{ k} \\ \Rightarrow RH \cos 53.13^\circ &= 0 \text{ k} \\ VF &= 0 \text{ k} \\ VG &= 0 \text{ k} \\ MF &= 0 \text{ k}' \\ MG &= 0 \text{ k}' \end{aligned}$$

## When 1 k at F

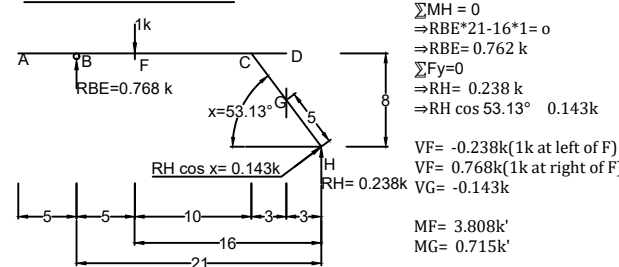

$$\begin{aligned} \sum M_H &= 0 \\ \Rightarrow RBE \cdot 21 - 16 \cdot 1 &= 0 \\ \Rightarrow RBE &= 0.762 \text{ k} \\ \sum F_y &= 0 \\ \Rightarrow RH &= 0.238 \text{ k} \\ \Rightarrow RH \cos 53.13^\circ &= 0.143 \text{ k} \\ VF &= -0.238 \text{ k (1k at left of F)} \\ VF &= 0.768 \text{ k (1k at right of F)} \\ VG &= -0.143 \text{ k} \\ MF &= 3.808 \text{ k}' \\ MG &= 0.715 \text{ k}' \end{aligned}$$

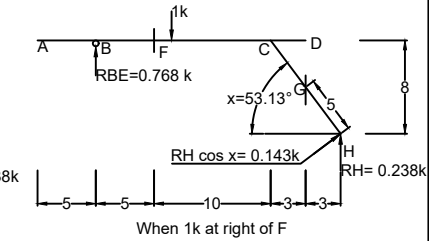
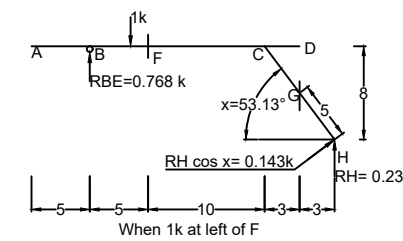

## When 1 k at C

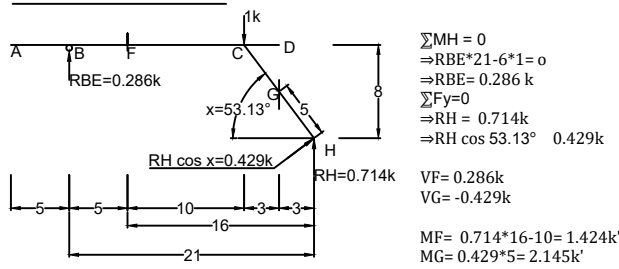

$$\begin{aligned} \sum M_H &= 0 \\ \Rightarrow RBE \cdot 21 - 6 \cdot 1 &= 0 \\ \Rightarrow RBE &= 0.286 \text{ k} \\ \sum F_y &= 0 \\ \Rightarrow RH &= 0.714 \text{ k} \\ \Rightarrow RH \cos 53.13^\circ &= 0.429 \text{ k} \\ VF &= 0.286 \text{ k} \\ VG &= -0.429 \text{ k} \\ MF &= 0.714 \cdot 16 - 10 = 1.424 \text{ k}' \\ MG &= 0.429 \cdot 5 = 2.145 \text{ k}' \end{aligned}$$

## When 1 k at D

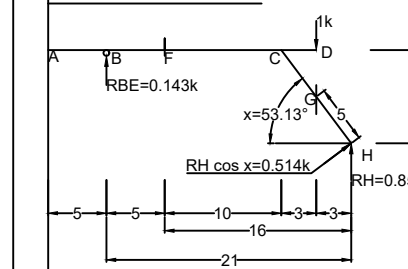

$$\begin{aligned} \sum M_H &= 0 \\ \Rightarrow RBE \cdot 21 - 3 \cdot 1 &= 0 \\ \Rightarrow RBE &= 0.143 \text{ k} \\ \sum F_y &= 0 \\ \Rightarrow RH &= 0.857 \text{ k} \\ \Rightarrow RH \cos 53.13^\circ &= 0.514 \text{ k} \\ VF &= 0.143 \text{ k} \\ VG &= -0.514 \text{ k} \\ MF &= 0.143 \cdot 5 = 0.715 \text{ k}' \\ MG &= 0.514 \cdot 5 = 2.571 \text{ k}' \end{aligned}$$

## Problem :11

When 1k at point A:

$$A_y = 1 k$$
$$R_{BD} = 0 k$$

$$V_a = 0 k$$
$$V_b = 0 k$$

$$M_A = 0 k - ft$$
$$M_a = 0 k - ft$$
$$M_b = 0 k - ft$$

When 1k at point a:

$$A_y = 1 k$$
$$R_{BD} = 0 k$$

$$V_a = 0 k \text{ (when 1k at left)}$$
$$V_a = 1 k \text{ (when 1k at right)}$$
$$V_b = 0 k$$

$$\sum M_A = 0$$
$$\Rightarrow M_A + 6 = 0$$

$$\Rightarrow M_A = -6 k - ft$$

$$\sum M_a = 0$$
$$\Rightarrow M_A + M_a + 6 = 0$$
$$\Rightarrow M_a - 6 + 6 = 0$$
$$\Rightarrow M_a = 0 k - ft$$
$$M_b = 0 k - ft$$

When 1k at point B:

$$A_y = 1 k$$
$$R_{BD} = 0 k$$

$$V_a = 1 k$$
$$V_b = 0 k$$

$$\sum M_A = 0$$
$$\Rightarrow M_A + 12 = 0$$

$$\Rightarrow M_A = -12 k - ft$$

$$\sum M_a = 0$$
$$\Rightarrow M_a + M_A + 9 = 0$$
$$\Rightarrow M_a - 12 + 6 = 0$$
$$\Rightarrow M_a = -6 k - ft$$
$$M_b = 0 k - ft$$

When 1k at point C:

$$R_{BD} \sin 36.87 = 1.4 k$$
$$R_{BD} = \frac{1.4}{\sin 36.87} = 2.33$$

$$R_E = -0.4$$
$$A_y = 1.4 k$$

$$V_a = 1.4 k$$
$$V_b = 0.4 k$$

$$\sum M_A = 0$$
$$\Rightarrow M_A + 1.4 * 12 = 0$$

$$\Rightarrow M_A = -16.8 k - ft$$

$$\sum M_a = 0$$
$$\Rightarrow M_a + M_A + 6 * 1.4 = 0$$
$$\Rightarrow M_a - 16.8 + 8.4 = 0$$
$$\Rightarrow M_a = -8.4 k - ft$$

$$\sum M_b = 0$$
$$\Rightarrow M_b + 0.4 * 6 = 0$$
$$\Rightarrow M_b = -2.4 k - ft$$

When 1k at point D:

$$R_{BD} \sin 36.87 = 1 k$$
$$R_{BD} = \frac{1}{\sin 36.87} = 1.667 k$$

$$R_E = 0 k$$
$$A_y = 1 k$$

$$V_a = 1 k$$
$$V_b = 0 k$$

$$\sum M_A = 0$$
$$\Rightarrow M_A + 12 * 1 = 0$$

$$\Rightarrow M_A = -12 k - ft$$

$$\sum M_a = 0$$
$$\Rightarrow M_a + M_A + 6 * 1 = 0$$
$$\Rightarrow M_a - 12 + 6 = 0$$
$$\Rightarrow M_a = -6 k - ft$$

$$M_b = 0 k - ft$$

When 1k at point b:

$$R_{BD} \sin 36.87 = 0.6 k$$
$$R_{BD} = \frac{0.6}{\sin 36.87} = 1 k$$

$$R_E = 0.4 k$$
$$A_y = 0.6 k$$

$$V_a = 0.6 k$$

$$V_b = -0.4 k \text{ (just at left of } b \text{)}$$

$$V_b = 0.6 k \text{ (just at right of } b \text{)}$$

$$\sum M_A = 0$$

$$\Rightarrow M_A + 0.6 * 12 = 0$$

$$\Rightarrow M_A = -7.2 k - ft$$

$$\sum M_a = 0$$

$$\Rightarrow M_a + M_A + 6 * 0.6 = 0$$

$$\Rightarrow M_a - 7.2 + 3.6 = 0$$

$$\Rightarrow M_a = -3.6 k - ft$$

$$\sum M_b = 0$$

$$\Rightarrow M_b - 0.4 * 6 = 0$$

$$\Rightarrow M_b = 2.4 k - ft$$

When 1k at point E:

$$R_{BD} = R_E = A_y = 0k$$

$$M_A = M_a = M_b = 0$$

$$V_a = V_b = 0 k$$

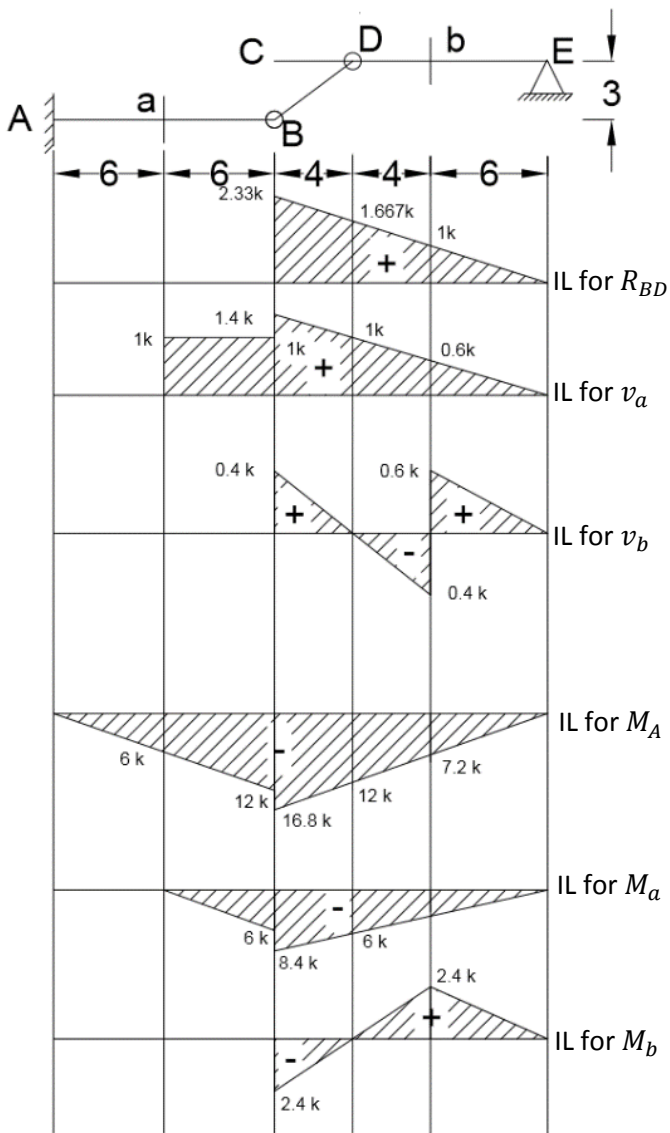

**Problem 12**  
 Draw ILD for RBD, MF, Va, Vb, Ma, Mb

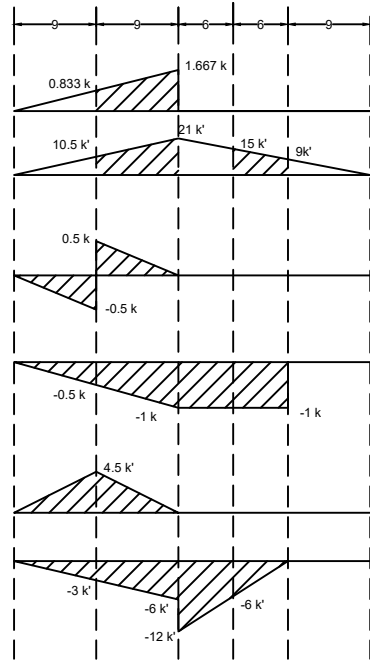
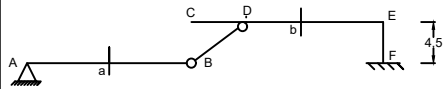

ILD for RBD

ILD for MF

ILD for Va

ILD for Vb

ILD for Ma

ILD for Mb

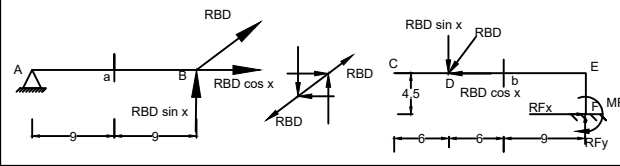

Created By -  
 Md.Ragib Nur Alam(CE- 13)  
 ragibnur.ce@gmail.com

**When 1 k at A**

$\sum MB = 0$   
 $\Rightarrow RA = 1 \text{ k}$   
 $\sum Fy = 0$   
 $\Rightarrow RBD \sin 36.87^\circ = 0 \text{ k}$   
 $\Rightarrow RBD \cos 36.87^\circ = 0 \text{ k}$   
 $\Rightarrow RBD = 0 \text{ k}$   
 $Va = 0 \text{ k}$   
 $Vb = 0 \text{ k}$   
 $Ma = 0 \text{ k'}$   
 $Mb = 0 \text{ k'}$

**When 1 k at a**

$\sum MB = 0$   
 $\Rightarrow RA \cdot 18 - 9 \cdot 1 = 0$   
 $\Rightarrow RA = 0.5 \text{ k}$   
 $\sum Fy = 0$   
 $\Rightarrow RBD \sin 36.87^\circ = 0.5 \text{ k}$   
 $\Rightarrow RBD \cos 36.87^\circ = 0.833 \text{ k}$   
 $\Rightarrow RBD = 0.833 \text{ k}$   
 $MF = 0.5 \cdot 15 + 0.667 \cdot 4.5 = 10.5 \text{ k'}$   
 $Va = -0.5 \text{ k}$  (When 1k at left of a)  
 $Va = 0.5 \text{ k}$  (When 1k at right of a)  
 $Vb = -0.5 \text{ k}$   
 $Ma = 0.5 \cdot 9 = 4.5 \text{ k'}$   
 $Mb = -3 \text{ k'}$

**When 1 k at B**

$\sum MB = 0$   
 $\Rightarrow RBD \sin 36.87^\circ \cdot 18 - 9 \cdot 1 = 0$   
 $\Rightarrow RBD \sin 36.87^\circ = 1 \text{ k}$   
 $\Rightarrow RBD \cos 36.87^\circ = 1.667 \text{ k}$   
 $\Rightarrow RBD = 1.667 \text{ k}$   
 $MF = 1 \cdot 15 + 1.333 \cdot 4.5 = 21 \text{ k'}$   
 $Va = 0 \text{ k}$   
 $Vb = -1 \text{ k}$   
 $Ma = 0 \text{ k'}$   
 $Mb = -6 \text{ k'}$

**When 1 k at C**

$RBD \sin 36.87^\circ = 0$   
 $\Rightarrow RBD \cos 36.87^\circ = 0 \text{ k}$   
 $\Rightarrow RBD = 0 \text{ k}$   
 $\sum Fy = 0$   
 $\Rightarrow RF = 0 \text{ k}$   
 $MF = 1 \cdot 21 = 21 \text{ k'}$   
 $Va = 0 \text{ k}$   
 $Vb = -1 \text{ k}$   
 $Ma = 0 \text{ k'}$   
 $Mb = -21 + 9 = -12 \text{ k'}$

**When 1 k at D**

$RBD \sin 36.87^\circ = 0$   
 $\Rightarrow RBD \cos 36.87^\circ = 0 \text{ k}$   
 $\Rightarrow RBD = 0 \text{ k}$   
 $\sum Fy = 0$   
 $\Rightarrow RF = 0 \text{ k}$   
 $MF = 1 \cdot 15 = 15 \text{ k'}$   
 $Va = 0 \text{ k}$   
 $Vb = -1 \text{ k}$   
 $Ma = 0 \text{ k'}$   
 $Mb = -6 \text{ k'}$

**When 1 k at E**

$RBD \sin 36.87^\circ = 0$   
 $\Rightarrow RBD \cos 36.87^\circ = 0 \text{ k}$   
 $\Rightarrow RBD = 0 \text{ k}$   
 $\sum Fy = 0$   
 $\Rightarrow RF = 0 \text{ k}$   
 $MF = 0 \text{ k'}$   
 $Va = 0 \text{ k}$   
 $Vb = 0 \text{ k}$   
 $Ma = 0 \text{ k'}$   
 $Mb = 0 \text{ k'}$

**When 1 k at b**

$RBD \sin 36.87^\circ = 0$   
 $\Rightarrow RBD \cos 36.87^\circ = 0 \text{ k}$   
 $\Rightarrow RBD = 0 \text{ k}$   
 $\sum Fy = 0$   
 $\Rightarrow RF = 0 \text{ k}$   
 $MF = 1 \cdot 9 = 9 \text{ k'}$   
 $Va = 0 \text{ k}$   
 $Vb = -1 \text{ k}$  (When 1k at left of b)  
 $Vb = 0 \text{ k}$  (When 1k at right of b)  
 $Ma = 0 \text{ k'}$   
 $Mb = 0 \text{ k'}$

**When 1 k at E**

$RBD \sin 36.87^\circ = 0$   
 $\Rightarrow RBD \cos 36.87^\circ = 0 \text{ k}$   
 $\Rightarrow RBD = 0 \text{ k}$   
 $\sum Fy = 0$   
 $\Rightarrow RF = 0 \text{ k}$   
 $MF = 0 \text{ k'}$   
 $Va = 0 \text{ k}$   
 $Vb = 0 \text{ k}$   
 $Ma = 0 \text{ k'}$   
 $Mb = 0 \text{ k'}$

**Problem 13**

Draw ILD for  $MA, Va, Vb, Ma, Mb$

As at left side of link there is a fixed support so the link transmits the load from right to left.  
The load transmitted from right to left should be considered minor.

What is going on at the link???

Horizontal force need not to be counted as right side of link/ hinge is roller. let us assume the internal hinge as link :)

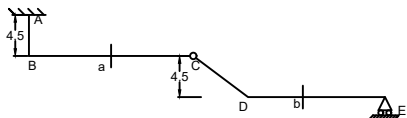

**When 1 k at B**

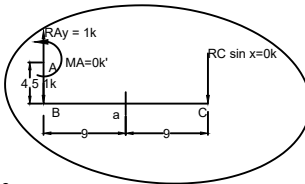

Taking, RC sin 36.87° as minor  
RC sin 36.87° = 0k  
RAY = 1k  
MA = 0k'  
  
Va = 0k  
Vb = 0k  
  
Ma = 0k'  
Mb = 0k'

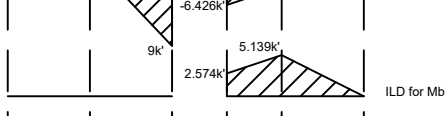
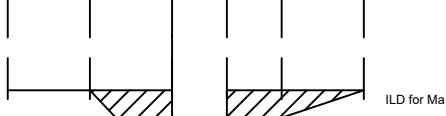
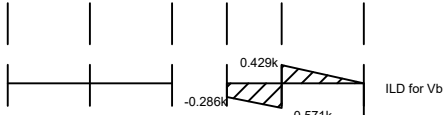
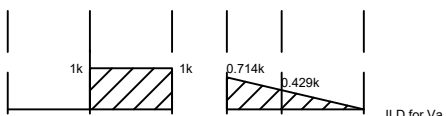
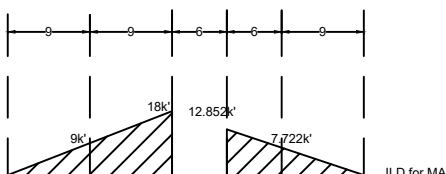
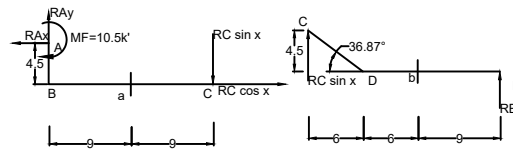
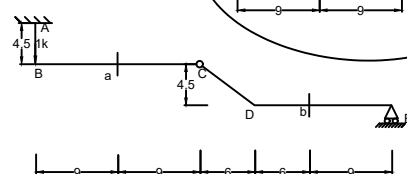

**When 1 k at a**

Taking, RC sin 36.87° as minor  
RC sin 36.87° = 0k  
RAY = 1k  
MA = 9k'  
  
Va = 0k (When 1k at left of a)  
Va = 1k (When 1k at right of a)  
Vb = 0k  
  
Ma = 0k'  
Mb = 0k'

When 1k at left of a  
When 1k at right of a

**When 1 k at C**

Taking, RC sin 36.87° as minor  
RC sin 36.87° = 0k  
RAY = 1k  
MA = 18k'  
  
Va = 1k  
Vb = 0k  
  
Ma = -9k'  
Mb = 0k'

**When 1 k at D**

$\sum ME = 0$   
 $\Rightarrow RC \sin 36.87^\circ * 21 - 15 * 1 = 0$   
 $\Rightarrow RC \sin 36.87 = 0.714 \text{ k} = R_{Ay}$   
 $\Rightarrow RC \cos 36.87^\circ = 0 \text{ R}_{Ax}$  Roller  
  
 $\sum Fy = 0$   
 $\Rightarrow RE = 0.286 \text{ k}$   
  
MA = 12.852k'  
  
Va = 0.714 k  
Vb = -0.286k  
  
Ma = -6.426k'  
Mb = 2.574 k'

Horizontal Component is not possible cause there is no hinge support

**When 1 k at b**

$\sum ME = 0$   
 $\Rightarrow RC \sin 36.87^\circ * 21 - 9 * 1 = 0$   
 $\Rightarrow RC \sin 36.87 = 0.429 \text{ k} = R_{Ay}$   
 $\Rightarrow RC \cos 36.87^\circ = 0 \text{ R}_{Ax}$   
  
 $\sum Fy = 0$   
 $\Rightarrow RE = 0.571 \text{ k}$   
  
MA = 0.429 \* 18 = 7.722k'  
  
Va = 0.429 k  
Vb = -0.571k (When 1k at left of b)  
Vb = 0.429 k (When 1k at right of b)  
  
Ma = 0.429 \* 9 = -3.861k'  
Mb = 0.571 \* 9 = 5.139 k'

**When 1 k at D**

Horizontal Component is not possible cause there is no hinge support

$\sum ME = 0$   
 $\Rightarrow RC \sin 36.87^\circ * 21 - 0 * 1 = 0$   
 $\Rightarrow RC \sin 36.87 = 0 \text{ k} = R_{Ay}$   
 $\Rightarrow RC \cos 36.87^\circ = 0 \text{ R}_{Ax}$  Roller  
  
 $\sum Fy = 0$   
 $\Rightarrow RE = 1 \text{ k}$   
  
MA = 0k'  
  
Va = 0k  
Vb = 0k  
  
Ma = 0k'  
Mb = 0k'

Problem 14:  
Draw ILD for  $V_a, V_b, V_c, M_a, M_b, M_c$  if the unit load moves from D to F.

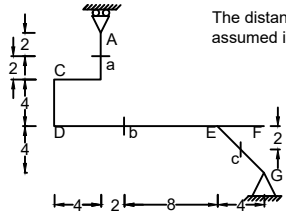

The distance of A from b is not given in assignment if assumed infinitesimal influence line would be different.

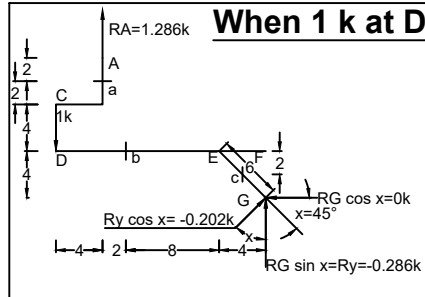
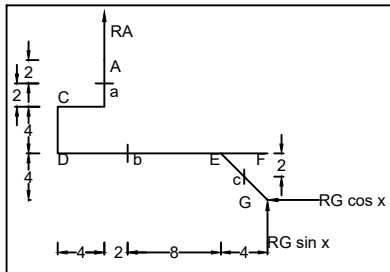
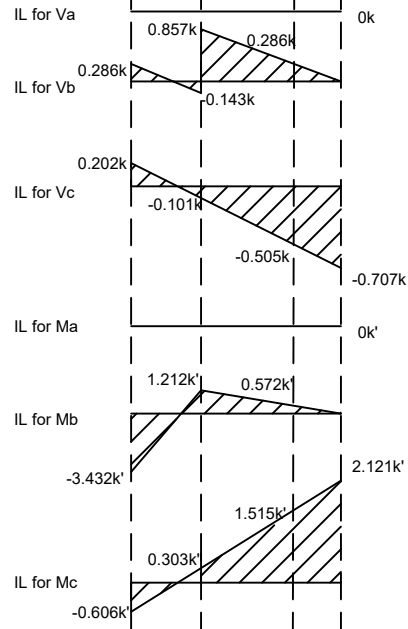

**When 1 k at D**

$\sum MG = 0$   
 $\Rightarrow RA \cdot 14 - 18 \cdot 1 = 0$   
 $\Rightarrow RA = \frac{18}{14} = 1.286 \text{ k}$

$\sum Fx = 0$   
 $\Rightarrow RG \cos 45^\circ = 0 \text{ k}$

$\sum Fy = 0$   
 $\Rightarrow RA - RG \sin 45^\circ = 1 \text{ k}$   
 $\Rightarrow RG \sin 45^\circ = -0.286 \text{ k}$

$V_a = 0 \text{ k}$   
 $V_b = 0.286 \text{ k}$   
 $V_c = -Ry \cos 45^\circ = -0.202 \text{ k}$

$M_a = 0 \text{ k'}$   
 $M_b = -0.286 \cdot 12 = -3.432 \text{ k'}$   
 $M_c = (-0.202 \cdot 3) = -0.606 \text{ k'}$

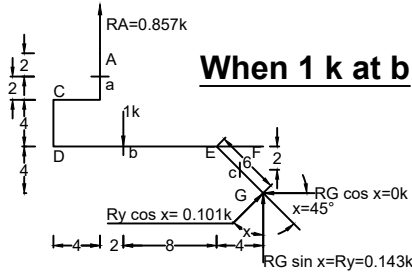

**When 1 k at b**

$\sum MG = 0$   
 $\Rightarrow RA \cdot 14 - 12 \cdot 1 = 0$   
 $\Rightarrow RA = \frac{12}{14} = 0.857 \text{ k}$

$\sum Fx = 0$   
 $\Rightarrow RG \cos 45^\circ = 0 \text{ k}$

$\sum Fy = 0$   
 $\Rightarrow RA - RG \sin 45^\circ = 1 \text{ k}$   
 $\Rightarrow RG \sin 45^\circ = 0.143 \text{ k}$

$V_a = 0 \text{ k}$   
 $V_b = -0.143 \text{ k}$  (When 1k at left of b)  
 $V_c = 0.857 \text{ k}$  (When 1k at left of b)  
 $V_c = -Ry \cos 45^\circ = -0.101 \text{ k}$

$M_a = 0 \text{ k'}$   
 $M_b = 0.101 \cdot 12 = 1.212 \text{ k'}$   
 $M_c = (0.101 \cdot 3) = 0.303 \text{ k'}$

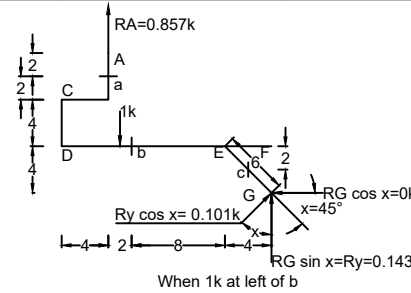

When 1k at left of b

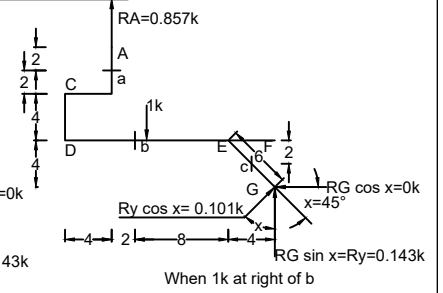

When 1k at right of b

**When 1 k at E**

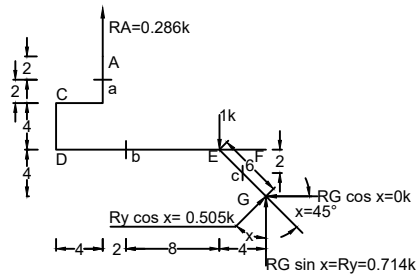

$\sum MG = 0$   
 $\Rightarrow RA \cdot 14 - 4 \cdot 1 = 0$   
 $\Rightarrow RA = \frac{4}{14} = 0.286 \text{ k}$

$\sum Fx = 0$   
 $\Rightarrow RG \cos 45^\circ = 0 \text{ k}$

$\sum Fy = 0$   
 $\Rightarrow RA - RG \sin 45^\circ = 1 \text{ k}$   
 $\Rightarrow RG \sin 45^\circ = 0.714 \text{ k}$

$V_a = 0 \text{ k}$   
 $V_b = 0.286 \text{ k}$   
 $V_c = -Ry \cos 45^\circ = -0.505 \text{ k}$

$M_a = 0 \text{ k'}$   
 $M_b = 0.286 \cdot 2 = 0.572 \text{ k'}$   
 $M_c = (0.505 \cdot 3) = 1.515 \text{ k'}$

**When 1 k at F**

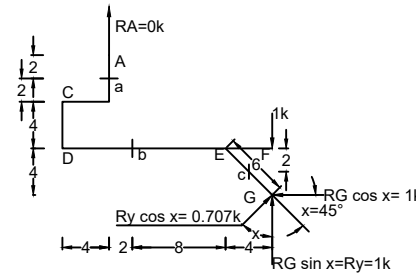

Created By -  
Md.Ragib Nur Alam(CE- 13)  
ragibnur.ce@gmail.com

$\sum MG = 0$   
 $\Rightarrow Ry \cdot 14 - 14 \cdot 1 = 0$   
 $\Rightarrow Ry = 1 \text{ k}$

$\sum Fx = 0$   
 $\Rightarrow RG \cos 45^\circ = 0 \text{ k}$

$\sum Fy = 0$   
 $\Rightarrow RA - RG \sin 45^\circ = 1 \text{ k}$   
 $\Rightarrow RA = 0 \text{ k}$

$V_a = 0 \text{ k}$   
 $V_b = 0 \text{ k}$   
 $V_c = -Ry \cos 45^\circ = -0.707 \text{ k}$

$M_a = 0 \text{ k'}$   
 $M_b = 0 \text{ k'}$   
 $M_c = (0.707 \cdot 3) = 2.121 \text{ k'}$

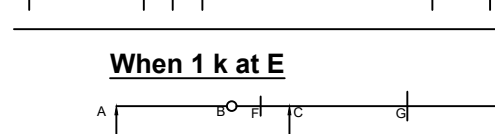
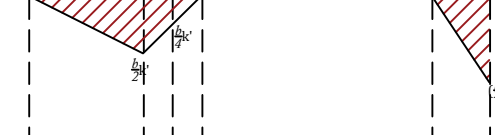
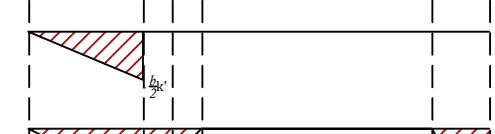
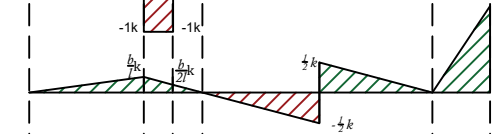
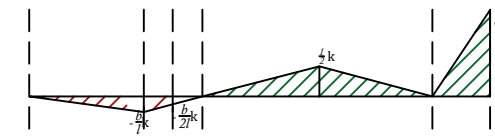
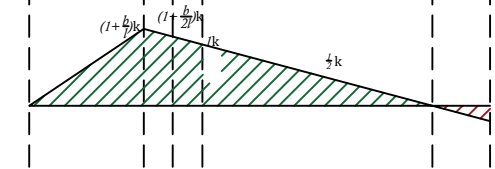
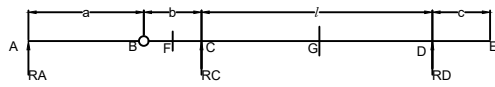

**When 1 k at E**

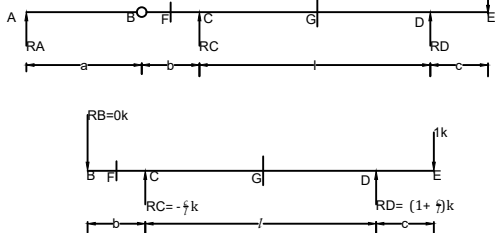

**When 1 k at A**

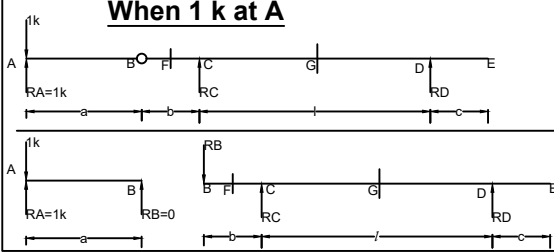

$\sum MB = 0$   
 $\Rightarrow RA \cdot a - a \cdot 1 = 0$   
 $\Rightarrow RA = 1 \text{ k}$   
 $\sum Fy = 0$   
 $\Rightarrow RA + RB = 1 \text{ k}$   
 $\Rightarrow RB = 0 \text{ k}$   
 for right of link  
 $RC = RD = 0 \text{ k}$

$VF = 0 \text{ k}$   
 $VG = 0 \text{ k}$

$MF = 0 \text{ k'}$   
 $MG = 0 \text{ k'}$

**When 1 k at F**

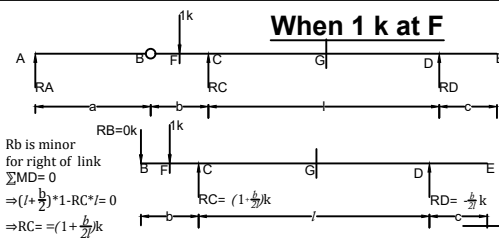

$\sum MA = 0$   
 $\Rightarrow RB \cdot a - a \cdot 1 = 0$   
 $\Rightarrow RB = 1 \text{ k}$

$\sum Fy = 0$   
 $\Rightarrow RA + RB = 1 \text{ k}$   
 $\Rightarrow RA = 0 \text{ k}$

for right of link  
 $\sum MD = 0$   
 $\Rightarrow (1+b) \cdot 1 - RC \cdot l = 0$   
 $\Rightarrow RC = \frac{1+b}{l} = (1 + \frac{b}{l}) \text{ k}$

$RB$  is minor  
 for right of link  
 $\sum MD = 0$   
 $\Rightarrow (1 + \frac{b}{l}) \cdot 1 - RC \cdot l = 0$   
 $\Rightarrow RC = (1 + \frac{b}{l}) \text{ k}$   
 $\sum Fy = 0$   
 $\Rightarrow RC + RD = 1$   
 $\Rightarrow RD = \frac{b}{l} \text{ k}$

$VF = -1 \text{ k}$  (When 1k at left of F)  
 $VF = 0 \text{ k}$  (When 1k at right of F)  
 $VG = \frac{b}{l} \text{ k}$

$MF = 0 \text{ k'}$   
 $MG = -\frac{b}{l} \cdot \frac{l}{2} = -\frac{1}{2} \text{ k'}$

When 1k at left of F

When 1k at right of F

**When 1 k at B**

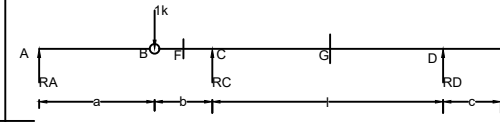

$\sum Fy = 0$   
 $\Rightarrow RC + RD = RB$   
 $\Rightarrow RD = \frac{b}{l} \text{ k}$

$VF = -1 \text{ k}$   
 $VG = \frac{b}{l} \text{ k}$

$MF = -1 \cdot \frac{b}{l} = -\frac{b}{l} \text{ k'}$   
 $MG = -\frac{b}{l} \cdot \frac{l}{2} = -\frac{1}{2} \text{ k'}$

**When 1 k at C**

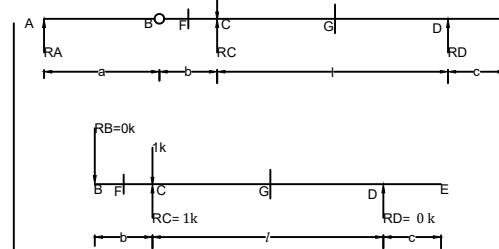

$RB$  is minor  
 for right of link  
 $\sum MD = 0$   
 $\Rightarrow l \cdot 1 - RC \cdot l = 0$   
 $\Rightarrow RC = 1 \text{ k}$   
 $\sum Fy = 0$   
 $\Rightarrow RC + RD = 1$   
 $\Rightarrow RD = 0 \text{ k}$

$VF = 0 \text{ k}$   
 $VG = 0 \text{ k}$   
 $MF = 0 \text{ k'}$   
 $MG = 0 \text{ k'}$

**When 1 k at D**

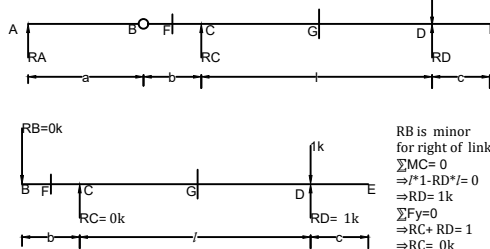

$RB$  is minor  
 for right of link  
 $\sum MC = 0$   
 $\Rightarrow l \cdot 1 - RD \cdot l = 0$   
 $\Rightarrow RD = 1 \text{ k}$   
 $\sum Fy = 0$   
 $\Rightarrow RC + RD = 1$   
 $\Rightarrow RC = 0 \text{ k}$

$VF = 0 \text{ k}$   
 $VG = 0 \text{ k}$   
 $MF = 0 \text{ k'}$   
 $MG = 0 \text{ k'}$

**When 1 k at G**

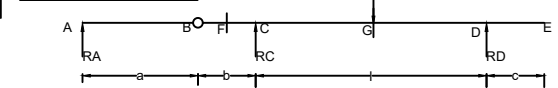

$RB$  is minor  
 for right of link  
 $\sum MD = 0$   
 $\Rightarrow \frac{l}{2} \cdot 1 - RC \cdot l = 0$   
 $\Rightarrow RC = \frac{1}{2} \text{ k}$   
 $\sum Fy = 0$   
 $\Rightarrow RC + RD = 1$   
 $\Rightarrow RD = \frac{1}{2} \text{ k}$

$VF = 0 \text{ k}$   
 $VG = -\frac{1}{2} \text{ k}$  (When 1k at left of G)  
 $VG = \frac{1}{2} \text{ k}$  (When 1k at right of G)  
 $MF = 0 \text{ k'}$   
 $MG = \frac{1}{2} \cdot \frac{l}{2} = \frac{1}{4} \text{ k'}$

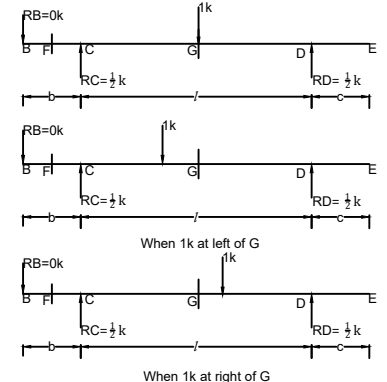

When 1k at right of G

Created by -  
 Md.Ragib Nur Alam(CE- 13)  
 ragibnur.ce@gmail.com

Problem 16  
Find shear in panel BC and moment at E

For a particular position of load, shear force at any point in panel will have same value. Therefore, instead of influence line for shear force at a point, influence line for shear force in a panel is drawn.

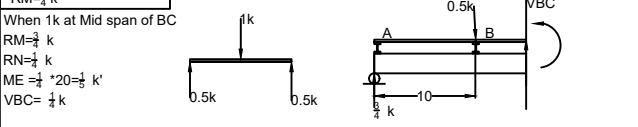
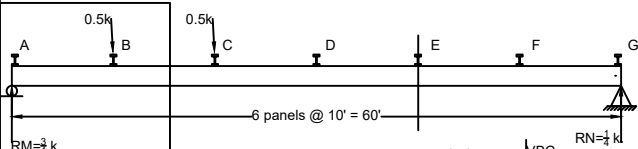
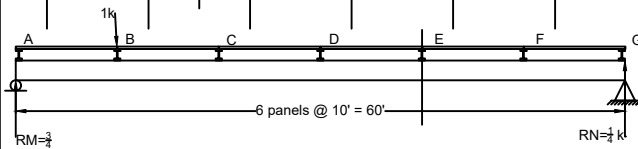
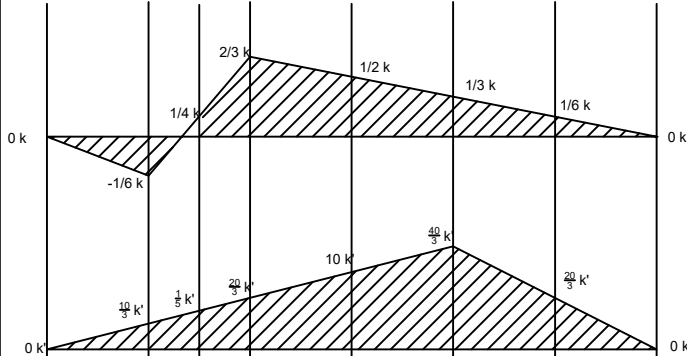
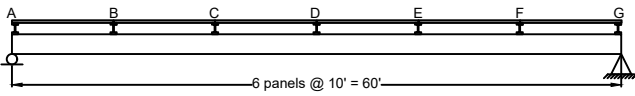

Md. Ragib Nur Alam  
CE 13  
ragibnur.ce@gmail.com

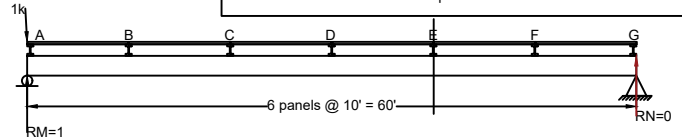
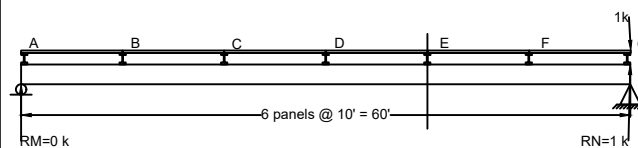
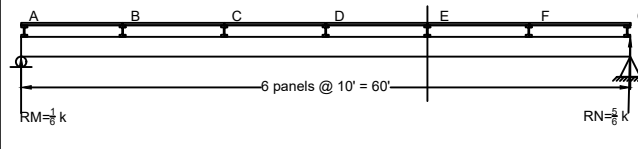
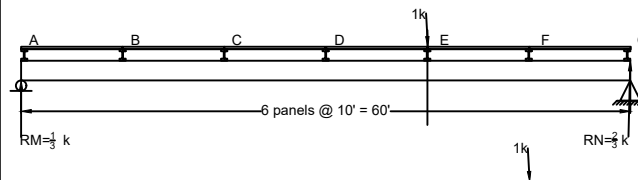

When 1k at 'A'  
RM=1k  
RN=0k  
ME=0k'  
VBC=0k

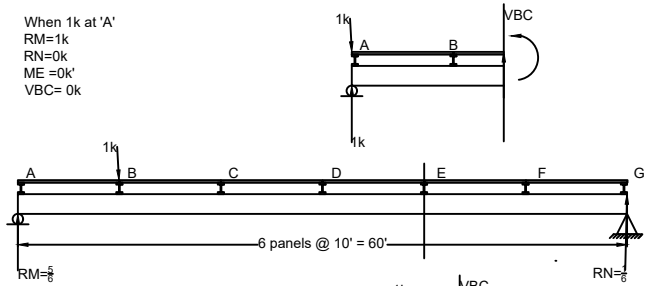

When 1k at B'  
RM=5/6 k  
RN=1/6 k  
ME = 1/3 \* 20 = 20/3 k'  
VBC = 1/3 k

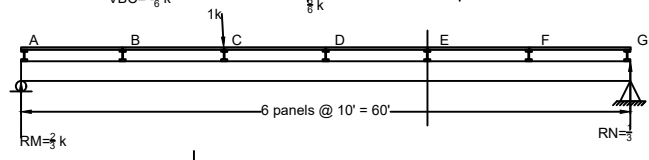

When 1k at C  
RM=2/3 k  
RN=1/3 k  
ME = 1/3 \* 20 = 20/3 k'  
VBC = 2/3 k

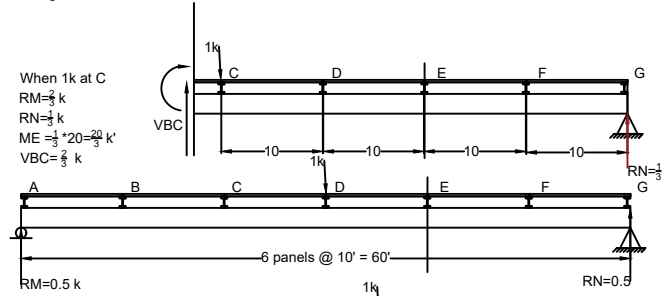

When 1k at D  
RM=0.5 k  
RN=0.5 k  
ME = 0.5 \* 20 = 10 k'  
VBC = 0.5 k

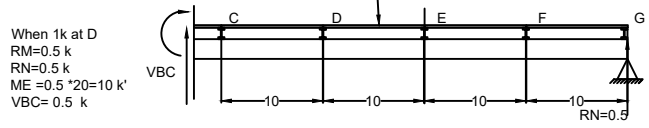

When 1k at E  
RM=1/3 k  
RN=2/3 k  
ME = 1/3 \* 20 = 20/3 k'  
VBC = 1/3 k

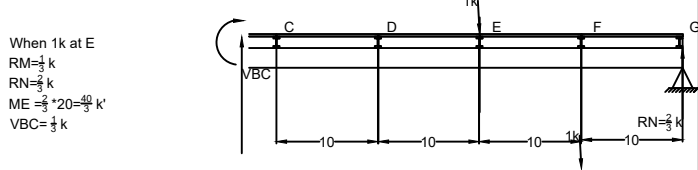

When 1k at F  
RM=1/6 k  
RN=5/6 k  
ME = -1 \* 10 + 5/6 \* 20 = 20/3 k'  
VBC = 1/6 k

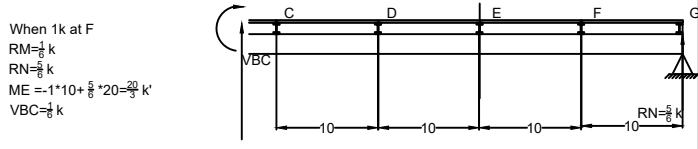

When 1k at G  
RM=0 k  
RN=1 k  
ME = 0 k'  
VBC = 0 k

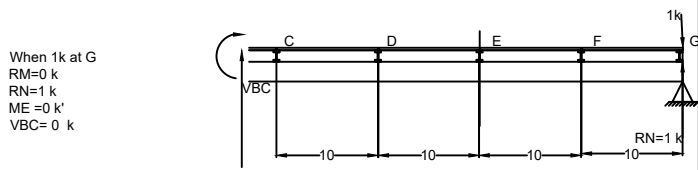

Problem 17  
Construct ILD for moment of Girder at E?

Girder with conventional end supported stringers, panel points are key points where influence line might change slope or have discontinuities.

For unusual stringer arrangement like this, Discontinuities in ILD may occur at key points other than panel points Like "C-D"

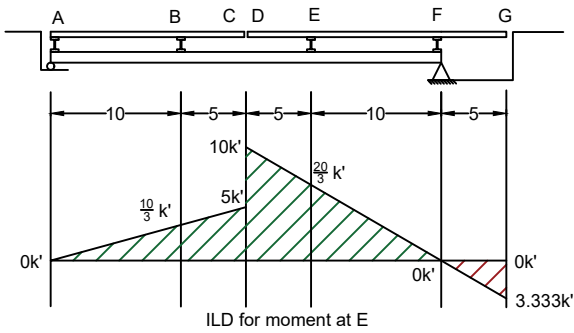

Find moment for 1k at A,C,D,F,G

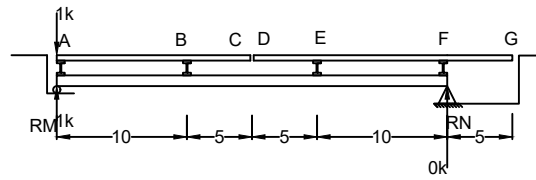

When 1k at 'A'  
RM=1k  
RN=0k  
ME=0k'

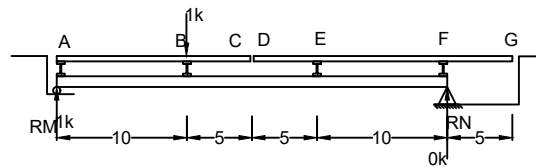

When 1k at B  
RM=2/3 k  
RN=1/3 k  
ME=10/3 k'

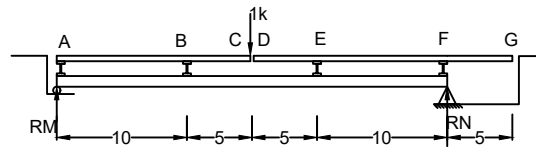

When 1k at 'C'  
RA=-0.5k  
RB=1.5k  
RM=0.5k  
RN=0.5k  
ME=5k'

Md. Ragib Nur Alam  
CE 13  
ragibnur.ce@gmail.com

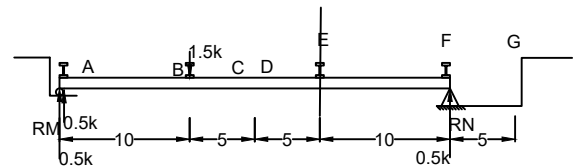
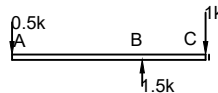

When 1k at 'D'  
RF=-0.5k  
RE=1.5k  
RM=0.5k  
RN=0.5k  
ME=0.5\*10+0.5\*10=10k'

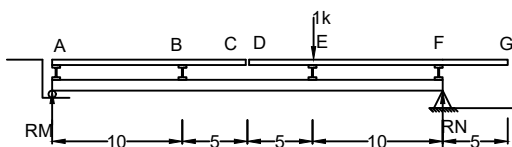
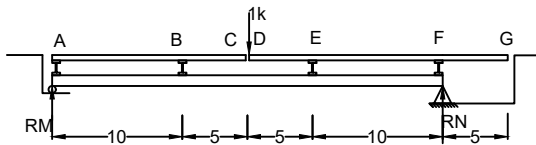

When 1k at 'E'  
RM=1/3 k  
RN=2/3 k  
ME=2/3\*10=20/3 k'

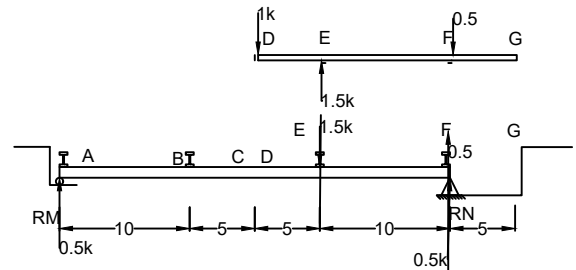

Md. Ragib Nur Alam  
CE 13  
ragibnur.ce@gmail.com

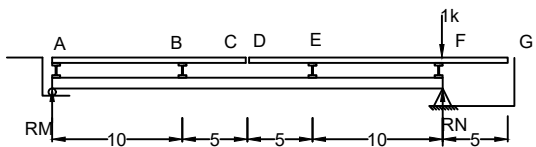

When 1k at F'  
RM=0 k  
RN=1k  
ME=1\*10-1\*10=0k'

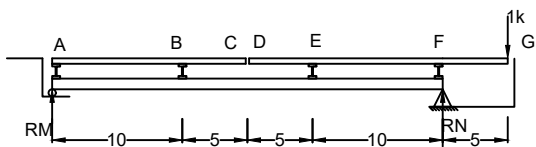

When 1k at G'  
RE=-0.5  
RF=1.5k  
RM=-0.167 k  
RN=1.167k  
ME=1.167\*10-1.5\*30=-3.333k'

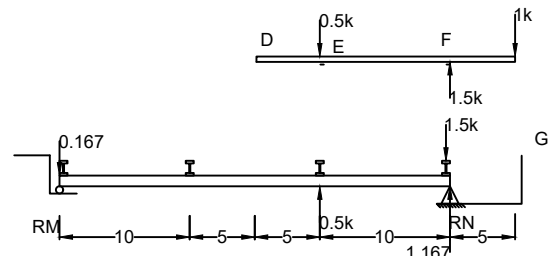

Problem 18

Find Shear and moment a,b,c,d, If load moves from A to D

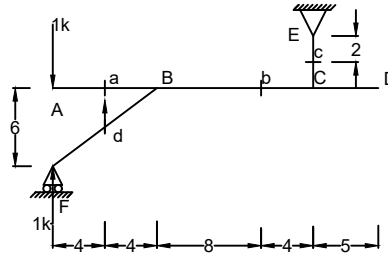
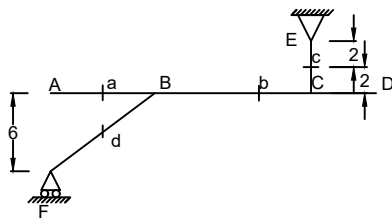

When 1k at A  
 RF=1k  
 RE=0.8k  
 Va=-1k  
 Vb=0k  
 Vc=0k  
 $Vd = 1 * \frac{4}{\sqrt{(4^2+3^2)}} = 0.8k$   
 Ma=-4 k'  
 Mb=0k'  
 Mc=0k'  
 $Md = 0.8 * \sqrt{(4^2+3^2)} = 4k'$

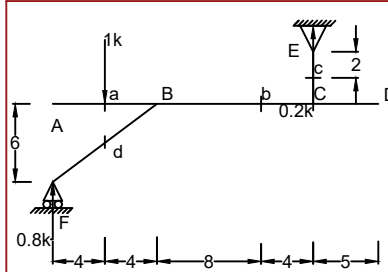
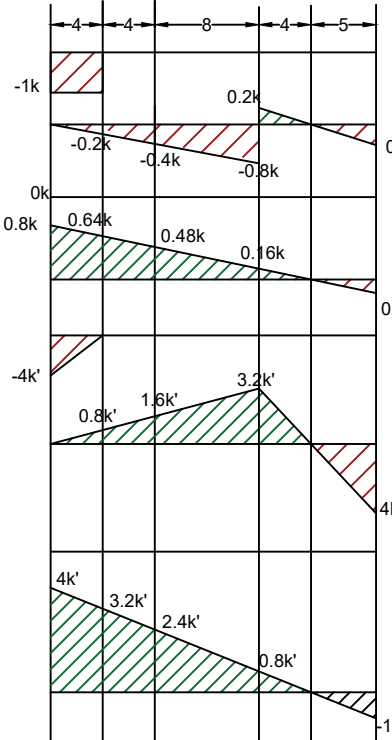
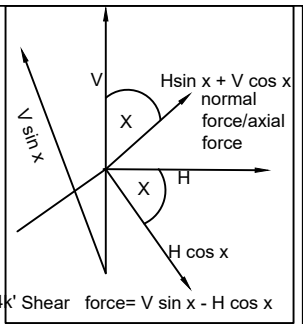

When 1k at a  
 RF=0.8k  
 RE=0.2k  
 Va=-1k(left)  
 Va=0k(right)  
 Vb=-0.2k  
 Vc=0k  
 $Vd = 0.8 * \frac{4}{\sqrt{(4^2+3^2)}} = 0.64k$   
 Ma=0 k'  
 Mb=0.8k'  
 Mc=0k'  
 $Md = 0.64 * \sqrt{(4^2+3^2)} = 3.2k'$

Md. Ragib Nur Alam  
 CE 13  
 ragibnur.ce@gmail.com

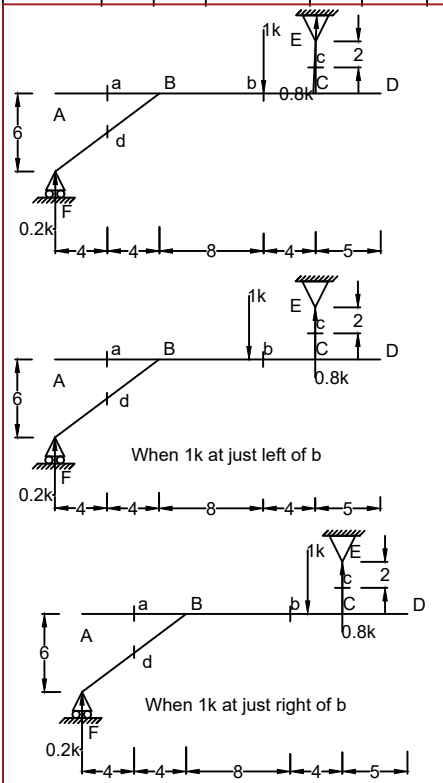
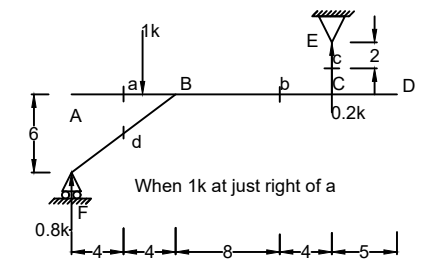
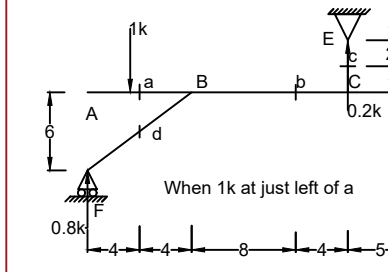

When 1k at b  
 RF=0.2k  
 RE=0.8k  
 Va=0k  
 Vb=-0.8k (left)  
 Vb=0.2k (right)  
 Vc=0k  
 $Vd = 0.2 * \frac{4}{\sqrt{(4^2+3^2)}} = 0.16k$   
 Ma=0 k'  
 Mb=3.2k'  
 Mc=0k'  
 $Md = 0.16 * \sqrt{(4^2+3^2)} = 0.8k'$

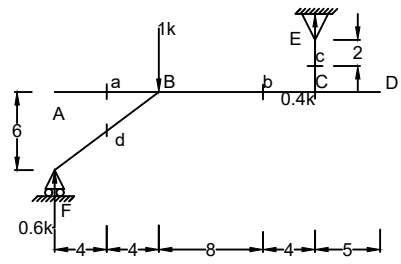

When 1k at B  
 RF=0.6k  
 RE=0.4k  
 Va=0k  
 Vb=-0.4k  
 Vc=0k  
 $Vd = 0.6 * \frac{4}{\sqrt{(4^2+3^2)}} = 0.48k$   
 Ma=0 k'  
 Mb=1.6k'  
 Mc=0k'  
 $Md = 0.48 * \sqrt{(4^2+3^2)} = 2.4k'$

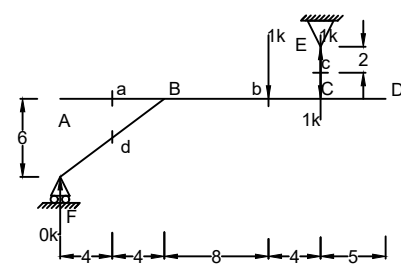

When 1k at C  
 RF=0k  
 RE=1k  
 Va=0k  
 Vb=0k  
 Vc=0k  
 Vd=0k  
 Ma=0 k'  
 Mb=0k'  
 Mc=0k'  
 Md=0k'

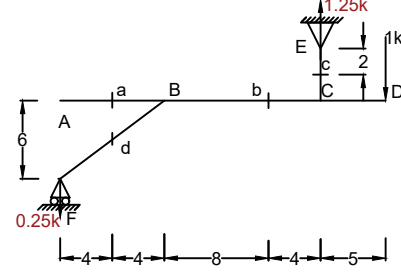

When 1k at D  
 RF=-0.25k  
 RE=1.25k  
 Va=0k  
 Vb=-0.25k  
 Vc=0k  
 $Vd = -0.25 * \frac{4}{\sqrt{(4^2+3^2)}} = -0.2k$   
 Ma=0 k'  
 Mb=-4k'  
 Mc=0k'  
 $Md = -0.2 * \sqrt{(4^2+3^2)} = -1k'$

Problem 19

Shear = sum of transverse forces either left or right of section

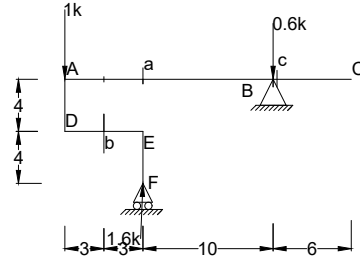
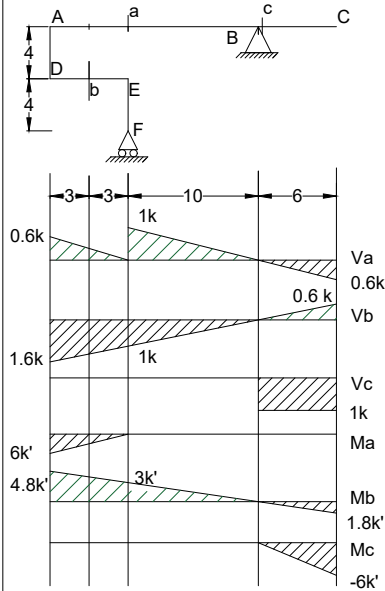

When 1k at A  
 $R_F = 1.6k$   $R_B = -0.6k$   
 $V_a = 0.6k$   
 $V_b = -1.6k$   
 $V_c = 0k$   
 $M_a = -0.6 \times 10 = -6k'$   
 $M_b = 1.6 \times 3 = 4.8k'$   
 $M_c = 0k$

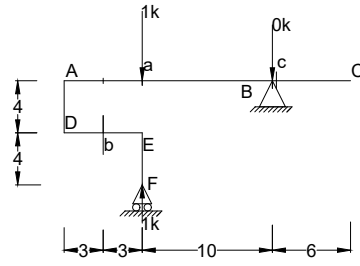

When 1k at a  
 $R_F = 1k$   $R_B = 0k$   
 $V_a = 0k$  (left)  
 $V_a = 1k$  (right)  
 $V_b = -1k$   
 $V_c = 0k$   
 $M_a = 0k'$   
 $M_b = 1 \times 3 = 3k'$   
 $M_c = 0k'$

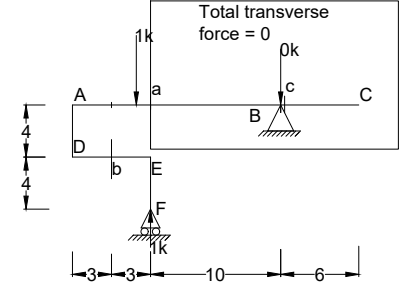

When 1k at just left of a

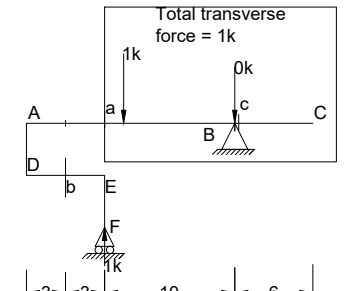

When 1k at just Right of a

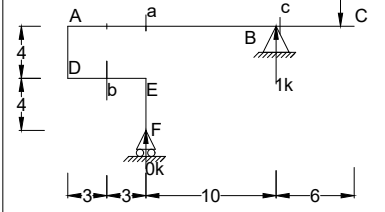

When 1k at B  
 $R_F = 0k$   $R_B = 1k$   
 $V_a = 0k$   
 $V_b = 0k$   
 $V_c = 0k$   
 $M_a = 0k'$   
 $M_b = 0k'$   
 $M_c = 0k'$

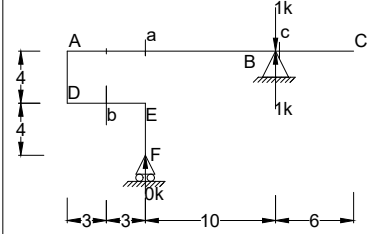

When 1k at c  
 $R_F = 0k$   $R_B = 1k$   
 $V_a = 0k$   
 $V_b = 0k$   
 $V_c = 0k$  (left)  
 $V_c = 1k$  (Right)  
 $M_a = 0k'$   
 $M_b = 0k'$   
 $M_c = 0k'$

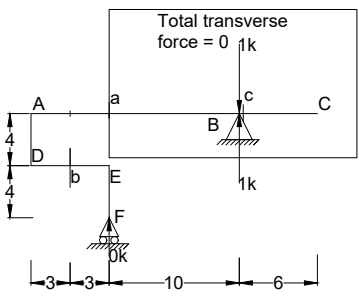

When 1k at just left of c

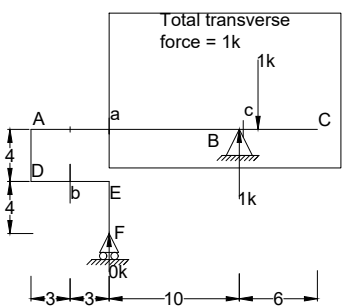

When 1k at just Right of c

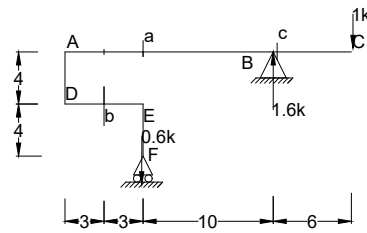

When 1k at C  
 $R_F = \frac{6}{10} = 0.6k$   $R_B = \frac{16}{10} = 1.6k$   
 $V_a = -1.6 + 1 = -0.6k$   
 $V_b = 0.6k$   
 $V_c = 1k$   
 $M_a = -1 \times 16 + 1.6 \times 10 = 0k'$   
 $M_b = -0.6 \times 3 = -1.8k'$   
 $M_c = -6k'$

Md. Ragib Nur Alam  
 CE 13  
 ragibnur.ce@gmail.com

# Problem 20

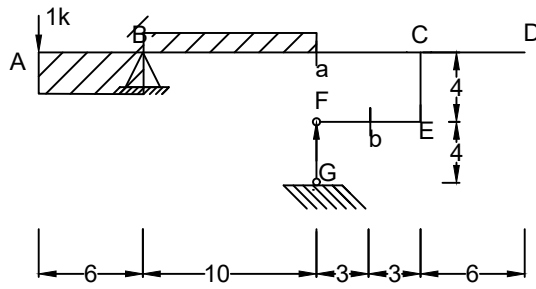
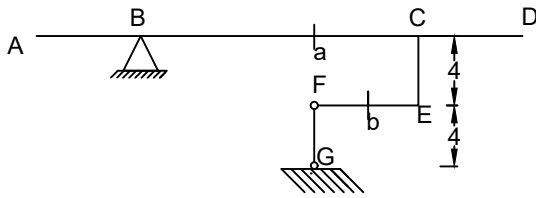

When 1k at A  
 $V_a = 1.6 - 1 = 0.6k$   
 $V_b = -0.6k$   
 $M_a = 0k'$   
 $M_b = 1.8k'$   
 $RFG = -0.6k$

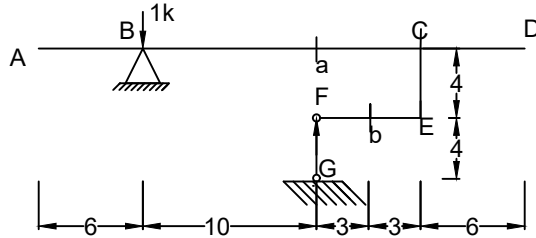

When 1k at B  
 $V_a = 0k$   
 $V_b = 0k$   
 $M_a = 0k'$   
 $M_b = 0k'$   
 $RFG = 0k$

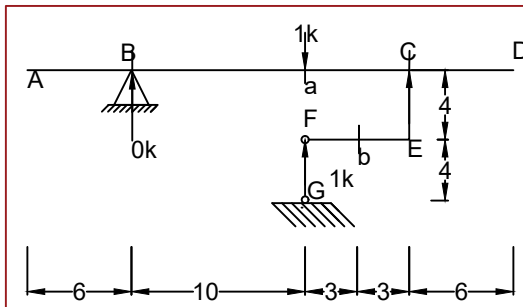
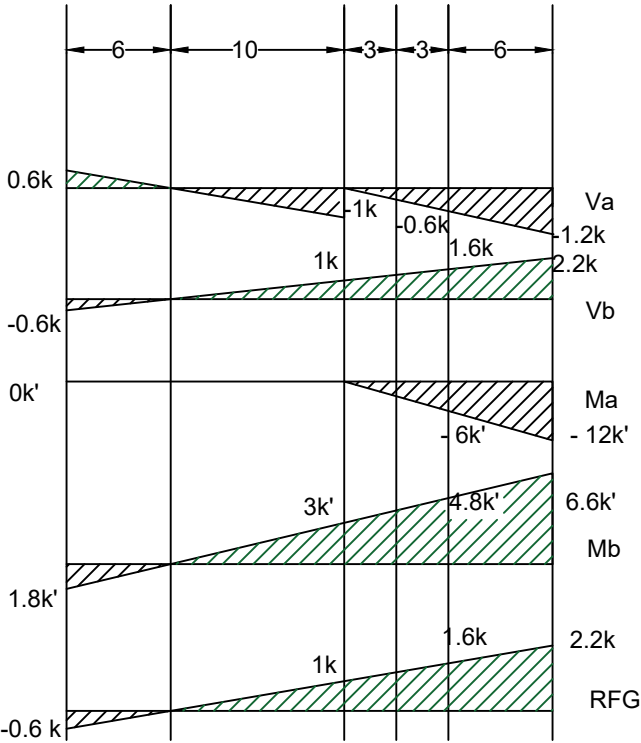

When 1k at a  
 $V_a = -1k$  (Left of a)  
 $V_a = 0k$  (Right of a)  
 $V_b = 1k$   
 $M_a = 0k'$   
 $M_b = 3k'$   
 $RFG = 1k$

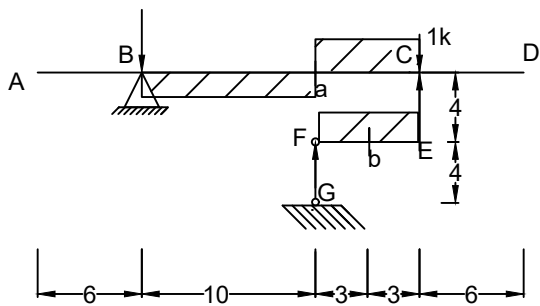

When 1k at C  
 $R_b = -0.6$   
 $V_a = -0.6k$   
 $V_b = 1.6k$   
 $M_a = -6k'$   
 $M_b = 4.8k'$   
 $RFG = 1.6k$

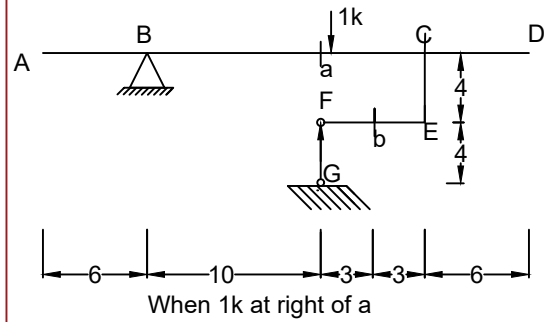

When 1k at right of a

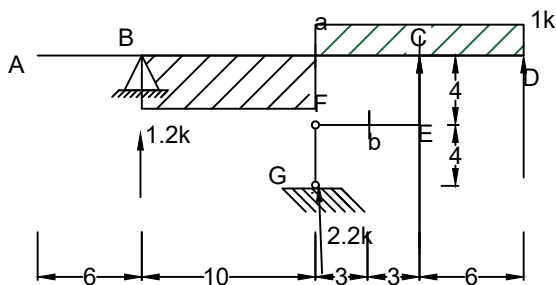

When 1k at D  
 $R_b = -1.2$   
 $V_a = -1.2k$   
 $V_b = 2.2k$   
 $M_a = -12k'$   
 $M_b = 6.6k'$   
 $RFG = \frac{22}{10} = 2.2k$

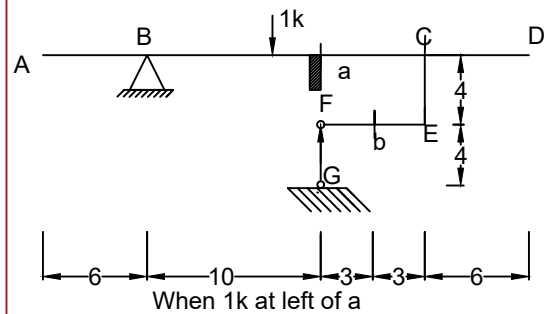

When 1k at left of a

Md. Ragib Nur Alam  
 CE 13  
 ragibnur.ce@gmail.com