

Influence Lines: An influence line is a diagram showing the variation in the shear, moment, stress in a member, reaction, or other direct function at a particular section or point or member, due to a unit load moving across the structure.

Construction of Influence Line: An influence line is constructed by plotting directly under the point where the unit load is placed an ordinate the height of which **represents to some scale** the value of the particular function being studied when the load is in that point.

Purpose of Influence Lines:

Influence lines can be used for two very important purposes:

1. To determine what position of live loads will lead to a maximum value of the particular function for which an influence line has been constructed.
2. To compute the value of that function with the loads so placed or, in fact, for any loading condition.

Theorem 1. To obtain the maximum value of a function due to a single concentrated live load, the load should be placed at the point where the ordinate to the influence line for that function is a maximum.

Theorem 2. The value of a function due to the action of a single concentrated live load equals the product of the magnitude of the load and the ordinate to the influence line for that function, measured at the point of application of the load.

Theorem 3. To obtain the maximum value of a function due to a uniformly distributed live load, the load should be placed over all those portions of the structure for which the ordinates to the influence line for that function have the sign of the character of the function desired.

Theorem 4. The value of a function due to a uniformly distributed live load is equal to the product of the intensity of the loading and the net area under that portion of the influence line, for that function under consideration, which corresponds to the portion of the structure loaded.

Preparation of Influence lines

1. Select function of influence line you need.
(Function – Reactions, shear force, bending moment, axial force, deflection etc.)

2. Place a unit load at various locations along the structure
3. Compute the value of the function for that particular position of the unit load.
4. Locate the magnitude of the function on the structure/structural member at current position of the unit load.
5. Draw a line by joining the ordinate along the member/structure.

Müller-Breslau Principle: May be stated as *“If an internal stress component, or reaction component, is considered to act through some small distance and thereby to deflect or displace a structure, the curve of the deflection or displaced structure will be, to some scale, the influence line for the stress or reaction component.”*

Determinant structures:

Draw IL diagrams for R_A , R_B , V_a and M_a of the following structures as a unit load moves from A to C. Find maximum effect of above function due to 40 kips live loads.

When a unit load at A.

$$R_{Ay} = 1.0, \quad R_B = 0.0, \quad V_a = +0.0,$$

$$M_a = 0.0$$

When a unit load at just left a ,

$$R_{Ay} = 0.6, \quad R_B = 0.4, \quad V_a = -0.4,$$

$$M_a = +6.0$$

When a unit load at just right of a ,

$$R_{Ay} = 0.6, \quad R_B = 0.4, \quad V_a = +0.6,$$

$$M_a = +6.0$$

When a unit load at B.

$$R_{Ay} = 0.0, \quad R_B = 1.0, \quad V_a = 0.0,$$

$$M_a = 0.0$$

When a unit load at C.

$$R_{Ay} = -0.2, \quad R_B = 1.2, \quad V_a = -0.2,$$

$$M_a = -2.0$$

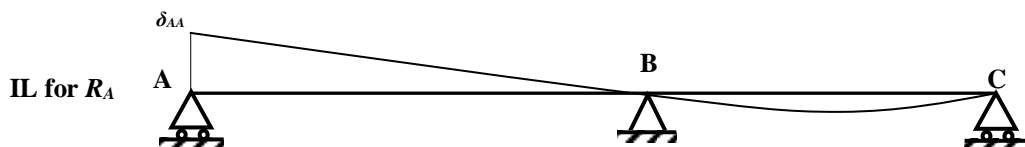
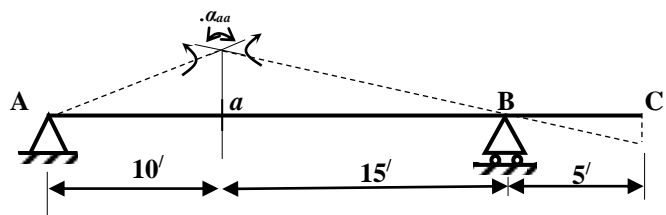
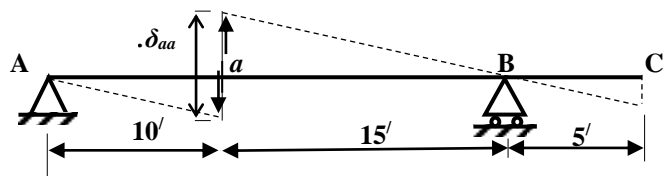
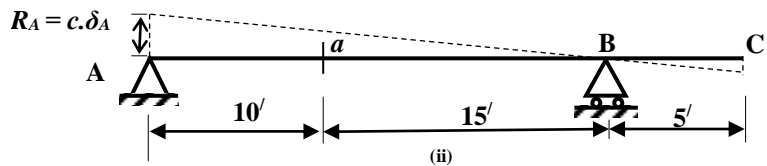
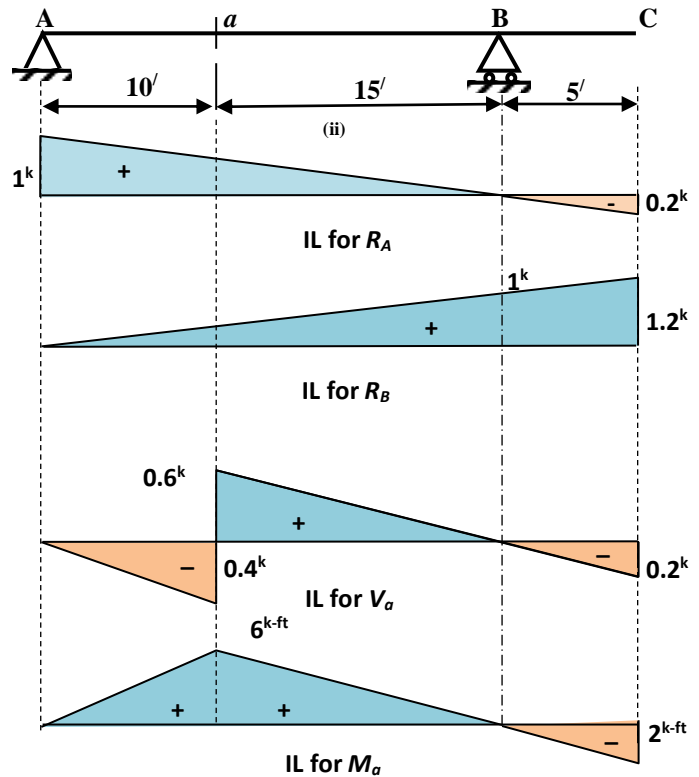

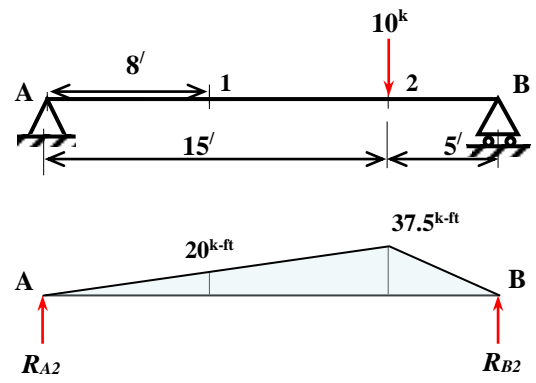
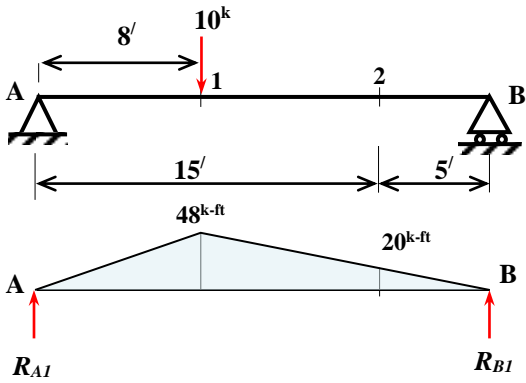
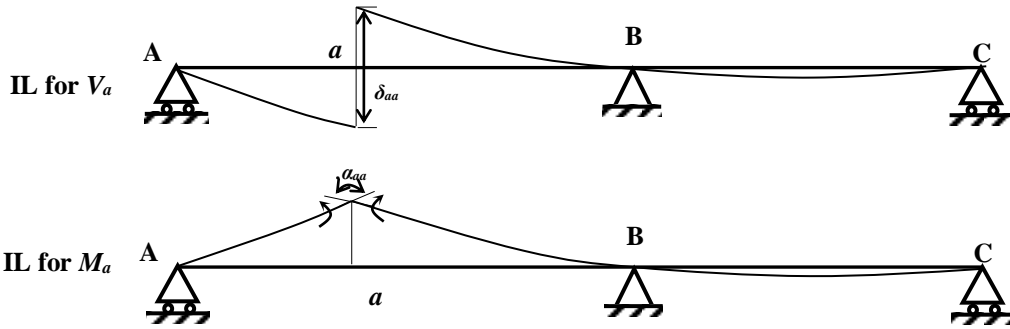

$$\sum M_A = \frac{48 \cdot 8}{2} \times \frac{2}{3} \times 8 + \frac{48 \cdot 12}{2} \left(8 + \frac{1}{3} \times 12 \right) - R_{B1} \times 20 = 0; \quad R_{B1} = 224 \text{ k-ft}$$

$$\delta_{21} = \left(224 \times 5 - \frac{1}{2} \times 20 \times 5 \times \frac{1}{3} \times 5 \right) / EI = \frac{1036.67}{EI}$$

$$\sum M_B = \frac{37.5 \cdot 5}{2} \times \frac{2}{3} \times 5 + \frac{37.5 \cdot 15}{2} \left(5 + \frac{1}{3} \times 15 \right) - R_{A1} \times 20 = 0; \quad R_{B1} = 156.25 \text{ k-ft}$$

$$\delta_{12} = \left(156.25 \times 8 - \frac{1}{2} \times 20 \times 8 \times \frac{1}{3} \times 8 \right) / EI = \frac{1036.67}{EI}$$

Therefore, $\delta_{21} = \frac{1036.67}{EI} = \delta_{12}$

Consider, a frame as shown below,

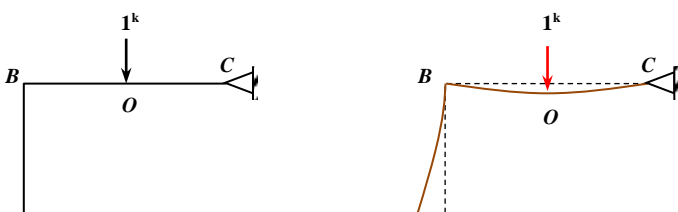

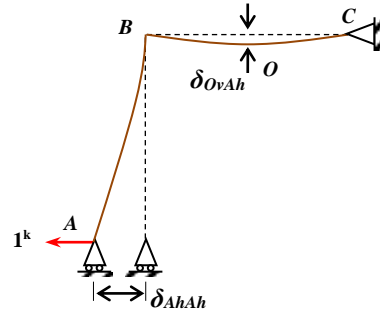

Fig. 3

By general method,

$$H_A = \frac{\delta_{AhOv}}{\delta_{AhAh}}$$

Maxwell's reciprocal deflection theorem,

$$\delta_{AhOv} = \delta_{OvAh}$$

Therefore,

$$H_A = \frac{\delta_{OvAh}}{\delta_{AhAh}} \quad (1)$$

From Eq. (1) indicates that the deflection curve of the member BC is, to the scale that δ_{AhAh} represents $1k$, **the influence lines for H_A for vertical load acting on BC .**

Similar way, applying a unit horizontal load acting at any point O on member AB , we can show that the deflected member AB in Fig. 3 is, to the same scale as above, **the influence line for H_A for horizontal load acting on AB .**

Müller-Breslau Principle for a continuous beam

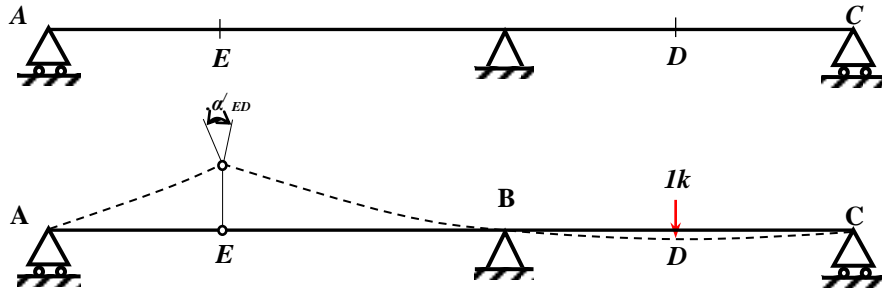

Remove moment resistance at section by applying hinge.

Shear and normal thrust component are not removed.

Apply 1 k load at D deflects the beam as shown above.

Then 1 k load at D removes and a pair of unit couples are applied on each end of hinge.

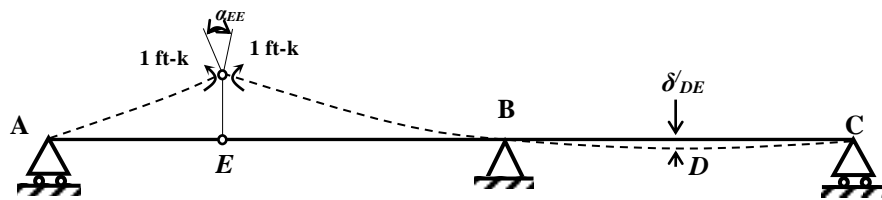

$$\text{Then, } M_E = \frac{\alpha'_{ED}}{\alpha_{EE}} = \frac{\delta_{DE}}{\alpha_{EE}}$$

IL for shear force at any section.

Cut the beam where IL for shear is required.

Assume a sliding device which permits transverse deflection between the two ends at the cut.

However, the two ends maintain the same slope that means the shear resistance is removed but moment resistance remains intact.

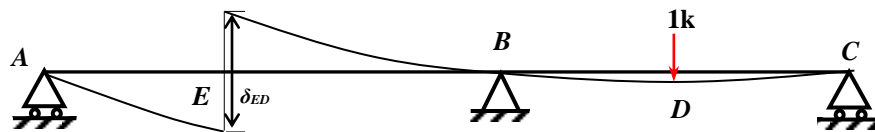

Fig.6

Load 1 k is applied at D resulting a relative linear deflection δ_{ED} as shown in above Fig. 6.

With the removal of 1 k load at D, a pair of 1 k loads are applied at E and the beam deflects as shown in Fig. 7.

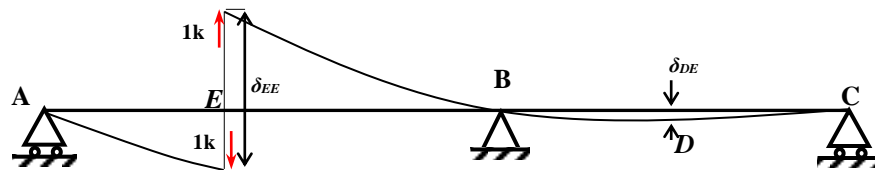

Fig.7

As before, the shear at E is given by

$$S_E = \frac{\delta_{ED}}{\delta_{EE}} = \frac{\delta_{DE}}{\delta_{EE}}$$

Example 1 Compute the ordinate, at intervals of 2.5 ft, of the influence line for R_A for the beam shown in Fig. 8. The moment of inertia is constant.

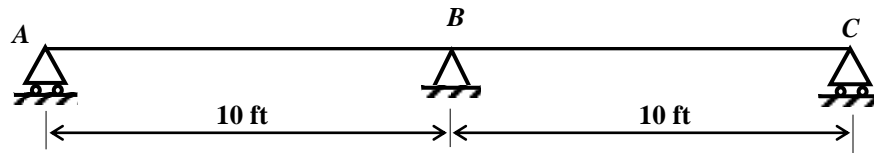

Fig. 8

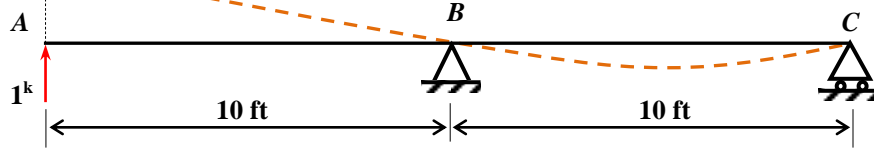

Fig. 9

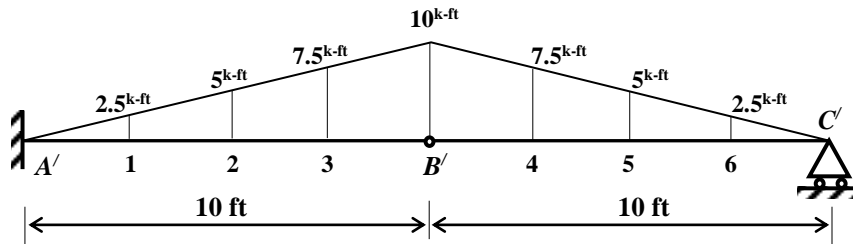

Fig. 10 Loaded conjugate beam

$$\sum M_{C'} = R_{B'} \times 10 - \frac{10 \times 10}{2} \times \frac{2}{3} \times 10 = 0; \quad R_{B'} = \frac{100}{3}$$

$$\sum F_y = \frac{100}{3} - \frac{10 \times 10}{2} + R_{C'} = 0; \quad R_{C'} = \frac{50}{3}$$

From A'B' portion of conjugate beam,

$$\sum F_y = -\frac{10 \times 10}{2} - R_{B'} + R_{A'} = 0; \quad R_{A'} = \frac{250}{3} = 83.33$$

$$\sum M_{A'} = R_{B'} \times 10 + \frac{10 \times 10}{2} \times \frac{2}{3} \times 10 - M_A = 0; \quad M_A = 666.67$$

$$M_6 = \frac{50}{3} \times 2.5 - 2.5 \times \frac{2.5}{2} \times \frac{2.5}{3} = 39.06 \quad M_5 = \frac{50}{3} \times 5 - 5 \times \frac{5}{2} \times \frac{5}{3} = 62.50$$

$$M_4 = \frac{50}{3} \times 7.5 - 7.5 \times \frac{7.5}{2} \times \frac{7.5}{3} = 54.69 \quad M_B = 0$$

$$M_3 = \frac{100}{3} \times 2.5 + 7.5 \times 2.5 \times \frac{2.5}{2} + 2.5 \times \frac{2.5}{2} \times \frac{2}{3} \times 2.5 = 111.98 \quad M_2 = \frac{100}{3} \times 5 + 5 \times 5 \times \frac{5}{2} + 5 \times \frac{5}{2} \times \frac{2}{3} \times 5 = 270.83$$

$$M_1 = \frac{100}{3} \times 7.5 + 2.5 \times 7.5 \times \frac{7.5}{2} + 7.5 \times \frac{7.5}{2} \times \frac{2}{3} \times 7.5 = 460.94$$

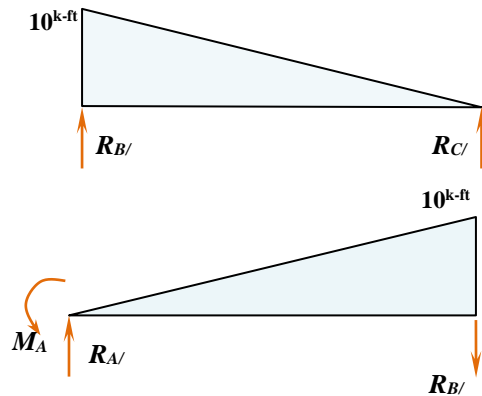

M_A	M_1	M_2	M_3	M_B	M_4	M_5	M_6	M_C
666.67	460.94	270.83	111.98	0.0	54.69	62.50	39.06	0
1	0.691	0.406	0.168	0.0	0.082	0.094	0.059	0.0

Example 1 Compute the ordinate, at intervals of 2.5 ft, of the influence line for moment at the midpoint of span BC for the beam shown in Fig. 11. The moment of inertia is constant.

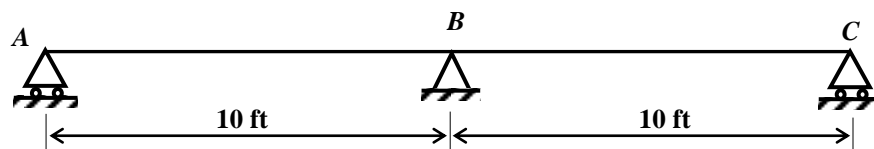

Fig. 11

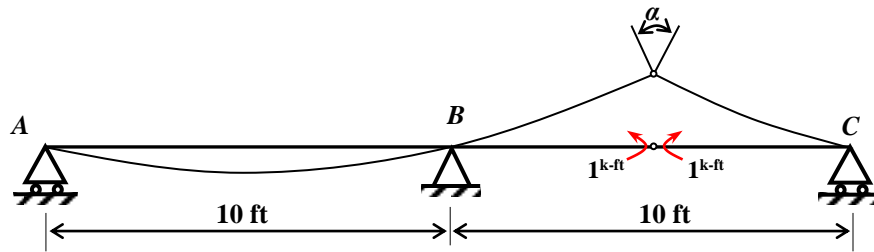

Fig. 12

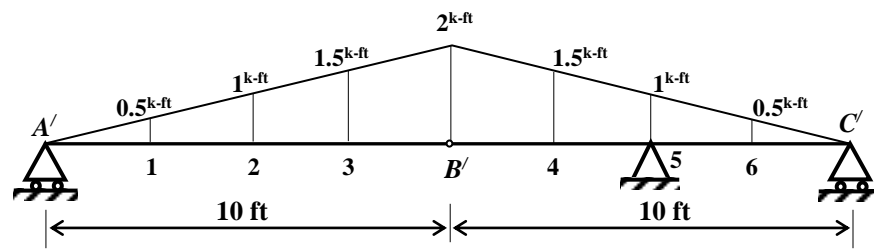

Fig. 13 Loaded conjugate beam

The shear on the pin at B'

$$\sum M_{B'} = R_{B'} \times 10 - \frac{2 \times 10}{2} \times \frac{2}{3} \times 10 = 0; \quad R_{B'} = \frac{20}{3}$$

$$V_{B'} = R_{B'} = \frac{20}{3}$$

$$\sum M_{C'} = R_{B'} \times 10 + \frac{2 \times 10}{2} \times \frac{2}{3} \times 10 - R_5 \times 5 = 0; \quad R_5 = 26.67$$

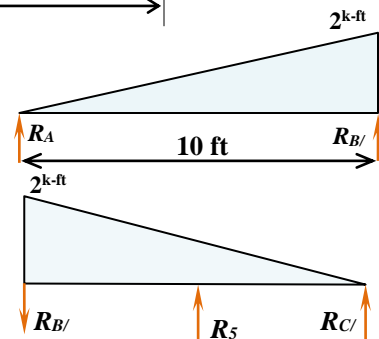

The sum of the shears in the conjugate beam to the right and left of the support at 5 will be the reaction at this point of the conjugate beam, and it will also be the relative value of the angle α in Fig. 12.

$$R_{C'} = 20 - 6.67 - 26.67 = 10.00 \quad (\downarrow)$$

$$R_{B'} = \frac{1}{3} \times \frac{10 \times 2}{2} = 3.33 \quad (\uparrow)$$

$$M_1 = 3.33 \times 2.5 - 0.5 \times \frac{2.5}{2} \times \frac{2.5}{3} = 7.81, \quad M_2 = 3.33 \times 5 - 1 \times \frac{5}{2} \times \frac{5}{3} = 12.50,$$

$$M_3 = 3.33 \times 7.5 - 1.5 \times \frac{7.5}{2} \times \frac{7.5}{3} = 10.94, \quad M_{B'} = 0,$$

$$M_4 = -6.67 \times 2.5 - 0.5 \times \frac{2.5}{2} \times \frac{2}{3} \times 2.5 - 1.5 \times 2.5 \times \frac{2.5}{2} = -22.40,$$

$$M_5 = -6.67 \times 5.0 - 1 \times \frac{5}{2} \times \frac{2}{3} \times 5 - 1 \times 5 \times 2.5 = -54.16, \quad M_6 = -10 \times 2.5 - 0.5 \times \frac{2.5}{2} \times \frac{2.5}{3} = -25.52,$$

The value of the influence line ordinate at each of the above sections is obtained by dividing each moment by relative $\alpha = 26.67$.

M_A	M_1	M_2	M_3	M_B	M_4	M_5	M_6	M_c
0	7.81	12.50	10.94	0.0	-22.40	-54.16	-25.52	0
0	0.293	0.469	0.410	0.0	-0.840	-2.031	-0.957	0.0

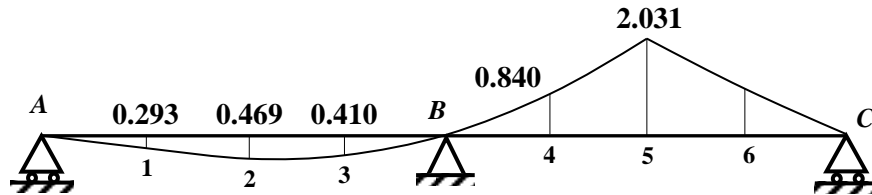
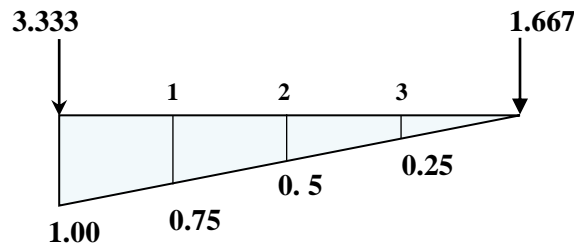

Fig. 14 Influence line diagram

Example 2



The value of the influence line ordinate at each of the above sections is obtained by dividing each moment by relative $\alpha = 3.333$. However, slope at A is zero due fixed support.

$$M_3 = -1.667 \times 2.5 + 0.25 \times \frac{2.5}{2} \times \frac{2.5}{3} = -3.906, \quad M_2 = -1.667 \times 5.0 + 0.5 \times \frac{5.0}{2} \times \frac{5.0}{3} = -6.252,$$

$$M_1 = -1.667 \times 7.5 + 0.75 \times \frac{7.5}{2} \times \frac{7.5}{3} = -5.469,$$

M_1	M_2	M_3
-5.469	-6.252	-3.906
-1.641	-1.876	-1.172

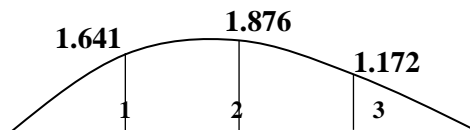

Example 1 Compute the ordinate, at intervals of 2.5 ft, of the influence line for shear at the midpoint of span BC for the beam shown in Fig. 15. The moment of inertia is constant.

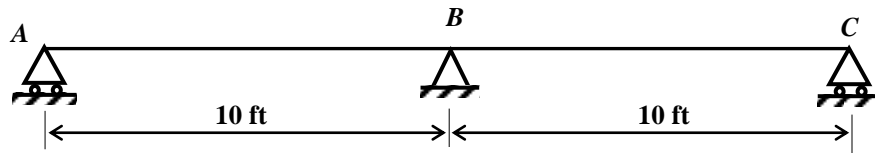

Fig. 15

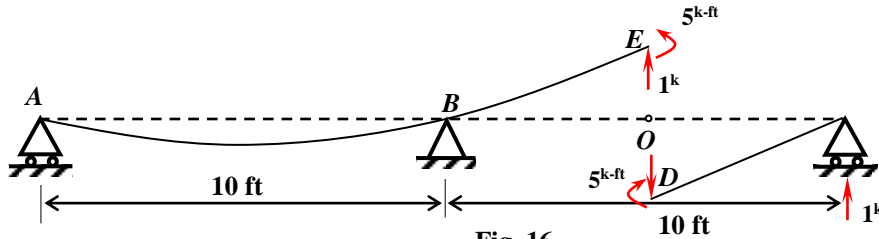

Fig. 16

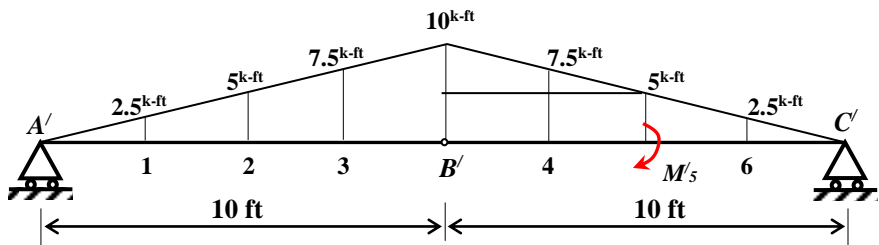

Fig. 17 Loaded conjugate beam

$$\sum M_{B'} = \frac{10 \times 10}{2} \times \frac{1}{3} \times 10 - R_{A'} \times 10 = 0; \quad R_{A'} = 16.67$$

$$\sum F_y = \frac{10 \times 10}{2} - 16.67 - R_{B'} = 0; \quad R_{B'} = 33.33 = V_{B'}$$

Considering the portion $A'B'$, $V_{B'} = \frac{10 \times 10}{2} - R_{A'} = 33.33$

Considering whole beam,

$$\sum F_y = -\frac{10 \times 20}{2} + 16.67 + R_{C'} = 0; \quad R_{C'} = 83.33$$

Considering the portion $B'C'$

$$\sum M_{C'} = -33.33 \times 10 - \frac{10 \times 10}{2} \times \frac{2}{3} \times 10 - M'_5 = 0; \quad M'_5 = 666.67$$

$$M_1 = 16.67 \times 2.5 - \frac{2.5 \times 2.5}{2} \times \frac{2.5}{3} = 39.06 \quad M_2 = 16.67 \times 5 - \frac{5 \times 5}{2} \times \frac{5}{3} = 62.52$$

$$M_3 = 16.67 \times 7.5 - \frac{7.5 \times 7.5}{2} \times \frac{7.5}{3} = 54.71 \quad M_6 = 83.33 \times 2.5 - \frac{2.5 \times 2.5}{2} \times \frac{2.5}{3} = 205.73$$

$$M_4 = -33.33 \times 2.5 - 7.5 \times 2.5 \times \frac{2.5}{2} - \frac{2.5 \times 2.5}{2} \times \frac{2.5}{3} = -109.37$$

$$M_{5R} = 83.333 \times 5 - \frac{5 \times 5}{2} \times \frac{5}{3} = 395.83 \quad M_{5L} = -666.67 + 395.83 = -270.84$$

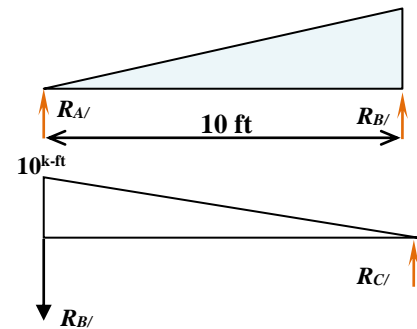

Each of the moment must be divided by relative deflection between D and E, as represent by $M'_5 = 666.67$

M_A	M_1	M_2	M_3	M_B	M_4	M_{5L}	M_{5R}	M_6	M_c
0	39.06	62.52	54.71	0.0	-109.37	-270.84	395.83	205.73	0
0	0.059	0.094	0.082	0.0	-0.164	-0.406	0.594	0.309	0.0

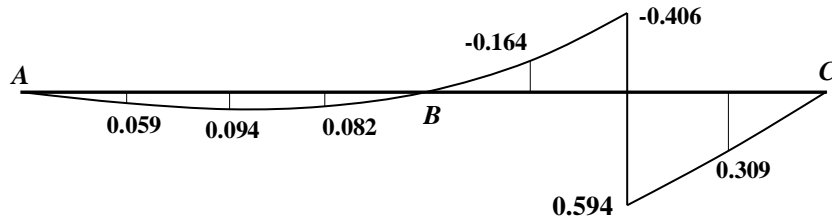

Fig. 17 IL diagram

Example 4 Compute ordinates of influence line for the moment at B in the continuous beam shown in figure below. The moment of inertia is constant. Compute the moment at center of each span.

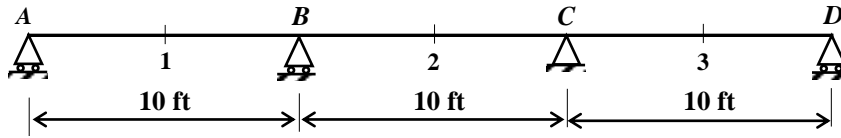

Fig. 18

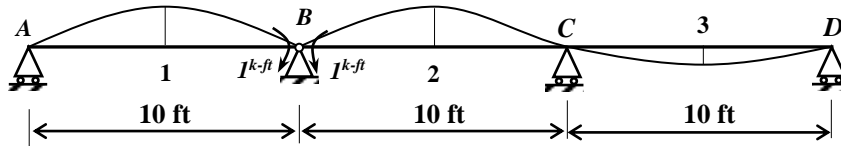

Fig. 19

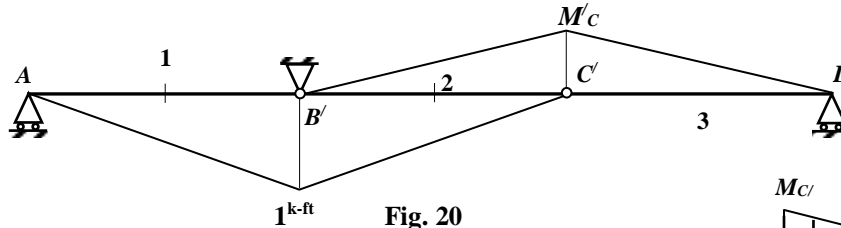

Fig. 20

From Fig. 21

$$\sum M_{D'} = R_{C'} \times 10 - \frac{1}{2} \times M_{C'} \times 10 \times \frac{2}{3} \times 10 = 0; \quad R_{C'} = \frac{10}{3} M_{C'}$$

$$R_{D'} = \frac{1}{2} \times 10 \times M_{C'} - \frac{10}{3} M_{C'} = \frac{5}{3} M_{C'} = \frac{5}{3} \times (0.25) = 0.417$$

From Fig. 22

$$\sum M_{B'} = R_{C'} \times 10 + \frac{1}{2} \times M_{C'} \times 10 \times \frac{2}{3} \times 10 - \frac{1}{2} \times 1 \times 10 \times \frac{10}{3} = 0;$$

$$M_{C'} = 0.25 \text{ k-ft}$$

From Fig. 23

$$\sum M_{B'} = R_{A'} \times 10 - \frac{1}{2} \times 1 \times 10 \times \frac{1}{3} \times 10 = 0; \quad R_{A'} = 1.67 \text{ k-ft}$$

$$R_{D'} = \frac{5}{3} M_{C'} = \frac{5}{3} \times (0.25) = 0.417 \quad R_{C'} = \frac{10}{3} M_{C'} = 0.833$$

Free body of whole conjugate beam

$$\sum F_y = -R_{A'} + R_{B'} + R_{D'} + \frac{1}{2} \times 1 \times 20 - \frac{1}{2} \times 0.25 \times 20 = 0;$$

$$\sum F_y = -1.67 + R_{B'} + 0.417 + \frac{1}{2} \times 1 \times 20 - \frac{1}{2} \times 0.25 \times 20 = 0; \quad R_{B'} = 6.247$$

$$\alpha_{BB} = R_{B'} = 6.247$$

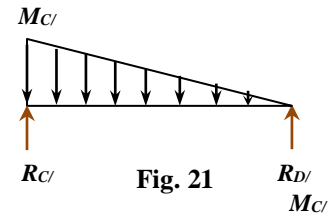

Fig. 21

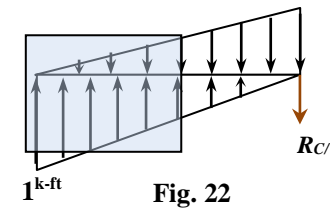

Fig. 22

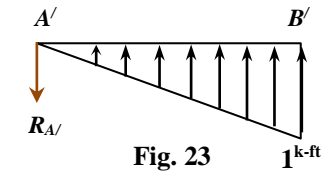

Fig. 23

M_A	M_I	M_B	M_2	M_C	M_3	M_D
0	-6.27	0	-4.69	0.0	1.564	0
0	-1.00	0	-0.75	0.0	0.25	0

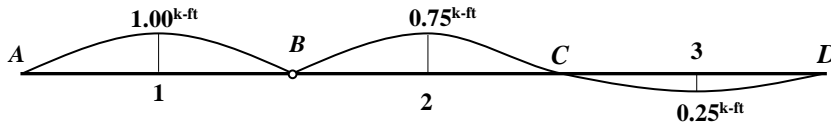

Fig. 24 IL diagram for M_B

Example 4 Compute ordinates of influence line for the moment at C in the continuous beam shown in figure below. The moment of inertia is constant.

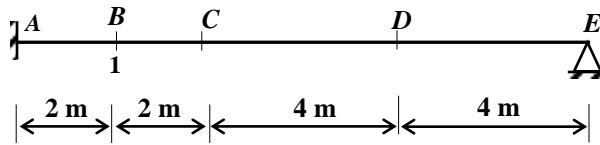

Fig. 25

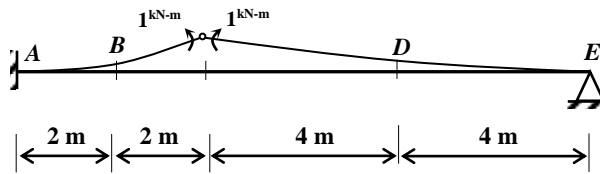
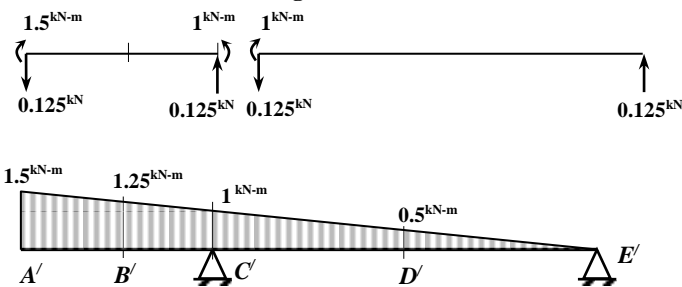

Fig. 26



$$\sum M_{E'} = \frac{1}{2} \times 1.5 \times 12 \times \frac{2}{3} \times 12 - R_{C'} \times 8 = 0; \quad R_{C'} = 9^{kN-m} = a_{CC}$$

$$\sum F_y = \frac{1}{2} \times 1.5 \times 12 - R_{C'} - R_{E'} = 0; \quad R_{E'} = 0$$

$$M_{B'} = -1.25 \times 2 \times 1 - 0.5 \times 0.25 \times 2 \times \frac{2}{3} \times 2 = -2.833^{kN-m}$$

$$M_{D'} = -0.5 \times 0.5 \times 4 \times \frac{1}{3} \times 4 = -1.333^{kN-m}$$

$$M_{C'} = -1.0 \times 4 \times 2 - 0.5 \times 0.5 \times 4 \times \frac{2}{3} \times 4 = -10.87^{kN-m}$$

M_A	M_B	M_C	M_D	M_E
0	-2.833	-10.87	-1.333	0.0
0	-0.315	-1.208	-0.148	0.0

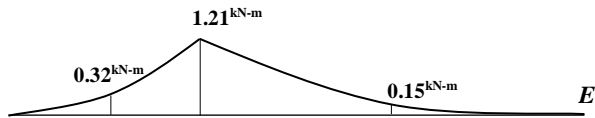

Qualitative Influence Lines by the Müller-Breslau Principle.

