

Pytel and Singer

Solution to Problems in Strength of Materials 4th Edition

Authors: Andrew Pytel and Ferdinand L. Singer

The content of this site is not endorsed by or affiliated with the author and/or publisher of this book.

Chapter 1 - Simple Stresses

Simple Stresses

1. Normal Stress
2. Shear Stress
3. Bearing Stress
4. Thin-walled Pressure Vessel

Normal Stresses

Stress is defined as the strength of a material per unit area of unit strength. It is the force on a member divided by area, which carries the force, formerly express in psi, now in N/mm² or MPa.

$$\sigma = \frac{P}{A}$$

where P is the applied normal load in Newton and A is the area in mm². The maximum stress in tension or compression occurs over a section normal to the load.

Normal stress is either tensile stress or compressive stress. Members subject to pure tension (or tensile force) is under tensile stress, while compression members (members subject to compressive force) are under compressive stress.

Compressive force will tend to shorten the member. Tension force on the other hand will tend to lengthen the member.

Solution to Problem 104 Normal Stress

A hollow steel tube with an inside diameter of 100 mm must carry a tensile load of 400 kN. Determine the outside diameter of the tube if the stress is limited to 120 MN/m².

Solution 104

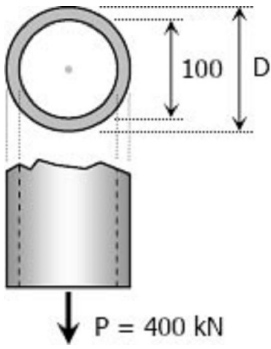

$$P = \sigma A$$

$$P = \sigma A$$

where:

$$P = 400 \text{ kN} = 400\,000 \text{ N}$$

$$\sigma = 120 \text{ MPa}$$

$$A = \frac{1}{4}\pi D^2 - \frac{1}{4}\pi(100^2)$$

$$A = \frac{1}{4}\pi(D^2 - 10\,000)$$

thus,

$$400\,000 = 120 \left[\frac{1}{4}\pi(D^2 - 10\,000) \right]$$

$$400\,000 = 30\pi D^2 - 300\,000\pi$$

$$D^2 = \frac{400\,000 + 300\,000\pi}{30\pi}$$

$$D = 119.35 \text{ mm} \rightarrow \text{answer}$$

Solution to Problem 105 Normal Stress

Strength of Materials 4th Edition by Pytel and Singer

Given:

Weight of bar = 800 kg

Maximum allowable stress for bronze = 90 MPa

Maximum allowable stress for steel = 120 MPa

Required: Smallest area of bronze and steel cables

Solution 105

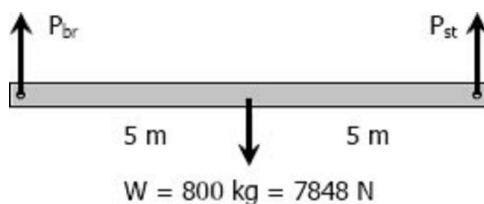

By symmetry:

$$P_{br} = P_{st} = \frac{1}{2}(7848)$$

$$P_{br} = 3924N$$

$$P_{st} = 3924N$$

For bronze cable:

$$P_{br} = \sigma_{br}A_{br}$$

$$3924 = 90A_{br}$$

$$A_{br} = 43.6 \text{ mm}^2 \rightarrow \text{answer}$$

For steel cable:

$$P_{st} = \sigma_{st}A_{st}$$

$$3924 = 120A_{st}$$

$$A_{st} = 32.7 \text{ mm}^2 \rightarrow \text{answer}$$

Solution to Problem 106 Normal Stress

Strength of Materials 4th Edition by Pytel and Singer

Given:

Diameter of cable = 0.6 inch

Weight of bar = 6000 lb

Required: Stress in the cable

Solution 106

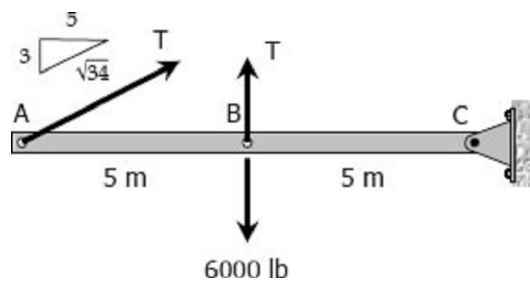

$$\Sigma M_C = 0$$

$$5T + 10 \left(\frac{3}{\sqrt{34}} T \right) = 5(6000)$$

$$T = 2957.13 \text{ lb}$$

$$T = \sigma A$$

$$2957.13 = \sigma \left[\frac{1}{4} \pi (0.6^2) \right]$$

$$\sigma = 10458.72 \text{ psi} \rightarrow \text{answer}$$

Solution to Problem 107 Normal Stress

Strength of Materials 4th Edition by Pytel and Singer

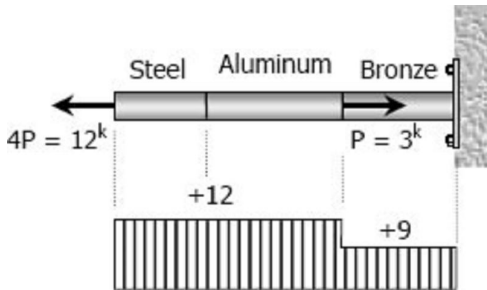
Given:Axial load $P = 3000 \text{ lb}$ Cross-sectional area of the rod $= 0.5 \text{ in}^2$ **Required:** Stress in steel, aluminum, and bronze sections**Solution 107**

For steel:

$$\sigma_{st} A_{st} = P_{st}$$

$$\sigma_{st} (0.5) = 12$$

$$\sigma_{st} = 24 \text{ ksi} \rightarrow \text{answer}$$

For aluminum:

$$\sigma_{al} A_{al} = P_{al}$$

$$\sigma_{al} (0.5) = 12$$

$$\sigma_{al} = 24 \text{ ksi} \rightarrow \text{answer}$$

For bronze:

$$\sigma_{br} A_{br} = P_{br}$$

$$\sigma_{br} (0.5) = 9$$

$$\sigma_{br} = 18 \text{ ksi} \rightarrow \text{answer}$$

Solution to Problem 108 Normal Stress

Strength of Materials 4th Edition by Pytel and Singer**Given:**Maximum allowable stress for steel $= 140 \text{ MPa}$ Maximum allowable stress for aluminum $= 90 \text{ MPa}$ Maximum allowable stress for bronze $= 100 \text{ MPa}$ **Required:** Maximum safe value of axial load P **Solution 108**

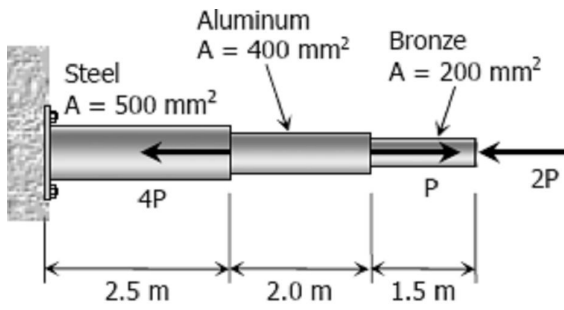

Figure P-108

For bronze:

$$\sigma_{br} A_{br} = 2P$$

$$100(200) = 2P$$

$$P = 10\,000\text{ N}$$

For aluminum:

$$\sigma_{al} A_{al} = P$$

$$90(400) = P$$

$$P = 36\,000\text{ N}$$

For Steel:

$$\sigma_{st} A_{st} = 5P$$

$$P = 14\,000\text{ N}$$

For safe P , use $P = 10\,000\text{ N} = 10\text{ kN} \rightarrow \text{answer}$

Solution to Problem 109 Normal Stress

Strength of Materials 4th Edition by Pytel and Singer

Given:

Maximum allowable stress of the wire = 30 ksi

Cross-sectional area of wire AB = 0.4 in^2

Cross-sectional area of wire AC = 0.5 in^2

Required: Largest weight W

Solution 109

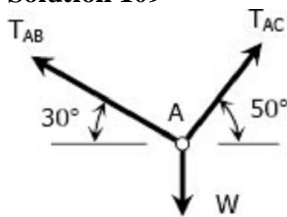

FBD of knot A

For wire AB: By sine law (from the force polygon):

$$\frac{T_{AB}}{\sin 40^\circ} = \frac{W}{\sin 40^\circ}$$

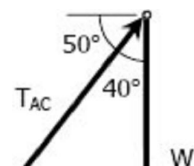

$$T_{AB} = 0.6527W$$

$$\sigma_{AB} A_{AB} = 0.6527W$$

$$30(0.4) = 0.6527W$$

$$W = 18.4 \text{ kips}$$

For wire AC:

$$\frac{T_{AC}}{\sin 60^\circ} = \frac{W}{\sin 80^\circ}$$

$$T_{AC} = 0.8794W$$

$$T_{AC} = \sigma_{AC} A_{AC}$$

$$0.8794W = 30(0.5)$$

$$W = 17.1 \text{ kips}$$

Safe load $W = 17.1 \text{ kips} \rightarrow \text{answer}$

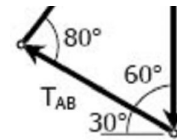

Force polygon of forces on knot A

Solution to Problem 110 Normal Stress

Strength of Materials 4th Edition by Pytel and Singer

Given:

Size of steel bearing plate = 12-inches square
 Size of concrete footing = 12-inches square
 Size of wooden post = 8-inches diameter
 Maximum allowable stress for wood = 1800 psi
 Maximum allowable stress for concrete = 650 psi

Required: Maximum safe value of load P

Solution 110

For wood:

$$P_w = \sigma_w A_w$$

$$P_w = 1800 \left[\frac{1}{4} \pi (8^2) \right]$$

$$P_w = 90\,477.9 \text{ lb}$$

From FBD of Wood:

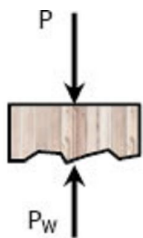

FBD of Wood

$$P = P_w = 90\,477.9 \text{ lb}$$

For concrete:

$$P_c = \sigma_c A_c$$

$$P_c = 650(122)$$

$$P_c = 93\,600 \text{ lb}$$

From FBD of Concrete:

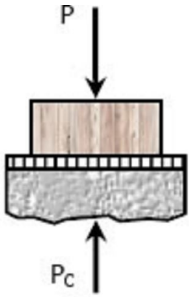

FBD of Concrete

$$P = P_c = 93\,600 \text{ lb}$$

Safe load $P = 90\,478 \text{ lb} \rightarrow \text{answer}$

Solution to Problem 111 Normal Stress

Strength of Materials 4th Edition by Pytel and Singer

Given:

Cross-sectional area of each member = 1.8 in^2

Required: Stresses in members CE, DE, and DF

Solution 111

From the FBD of the truss:

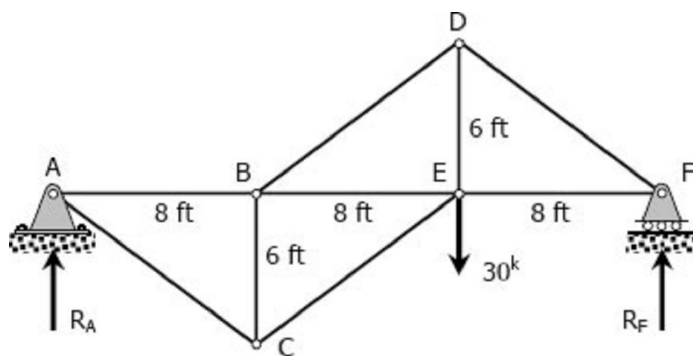

Free Body Diagram of Truss

$$\Sigma M_A = 0$$

$$24R_F = 16(30)$$

$$R_F = 20^k$$

At joint F:

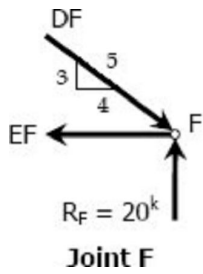

$$\Sigma F_V = 0$$

$$\frac{3}{5}DF = 20$$

$$DF = 33\frac{1}{3}^k \text{ (Compression)}$$

At joint D: (by symmetry)

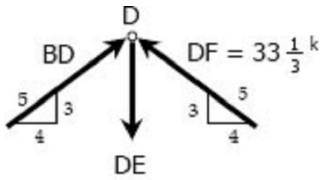

$$BD = DF = 33\frac{1}{3}^k \text{ (Compression)}$$

$$\Sigma F_V = 0$$

$$DE = \frac{3}{5}BD + \frac{3}{5}DF$$

$$DE = \frac{3}{5}(33\frac{1}{3}) + \frac{3}{5}(33\frac{1}{3})$$

$$DE = 40^k \text{ (Tension)}$$

At joint E:

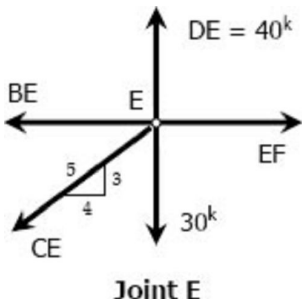

$$\sigma F_V = 0$$

$$\frac{3}{5}CE + 30 = 40$$

$$CE = 16\frac{2}{3}^k \text{ (Tension)}$$

Stresses:

Stress = Force/Area

$$\sigma_{CE} = \frac{16\frac{2}{3}}{1.8} = 9.26 \text{ ksi (Tension)} \rightarrow \text{answer}$$

$$\sigma_{DE} = \frac{40}{1.8} = 22.22 \text{ ksi (Tension)} \rightarrow \text{answer}$$

$$\sigma_{DF} = \frac{33\frac{1}{3}}{1.8} = 18.52 \text{ ksi (Compression)} \rightarrow \text{answer}$$

Solution to Problem 112 Normal Stress

Strength of Materials 4th Edition by Pytel and Singer

Given:

Maximum allowable stress in tension = 20 ksi

Maximum allowable stress in compression = 14 ksi

Required: Cross-sectional areas of members AG, BC, and CE

Solution 112

$$\Sigma F_V = 0$$

$$R_{AV} = 40 + 25 = 65^k$$

$$\Sigma_{AV} = 0$$

$$18R_D = 8(25) + 4(40)$$

$$R_D = 20^k$$

$$\Sigma F_H = 0$$

$$R_{AH} = R_D = 20^k$$

Check:

$$\Sigma M_D = 0$$

$$12R_{AV} = 18(R_{AH}) + 4(25) + 8(40)$$

$$12(65) = 18(20) + 4(25) + 8(40)$$

$$780 \text{ ft} \cdot \text{kip} = 780 \text{ ft} \cdot \text{kip} \text{ (OK!)}$$

For member AG (At joint A):

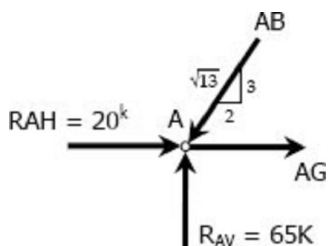

Joint A

$$\Sigma F_V = 0$$

$$\frac{3}{\sqrt{13}} AB = 65$$

$$AB = 78.12^k$$

$$\Sigma F_H = 0$$

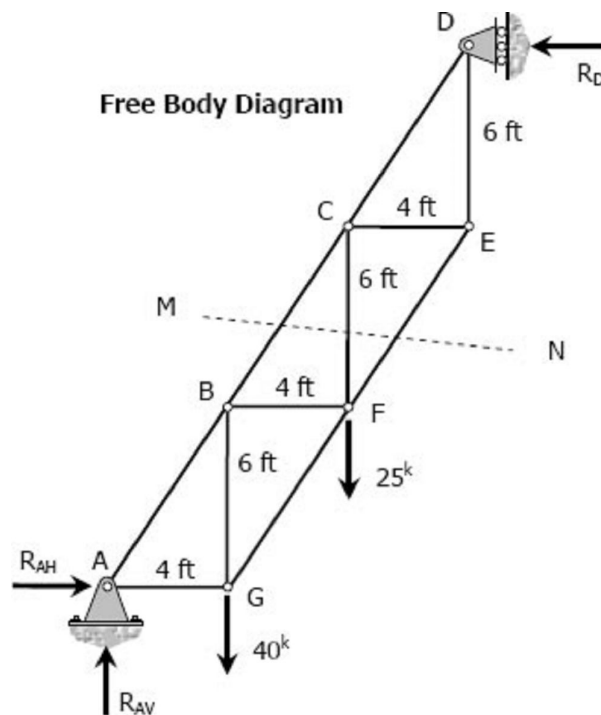

$$AG + 20 = \frac{2}{\sqrt{13}}AB$$

$$AG = 20.33^k \text{ Tension}$$

$$AG = \sigma_{\text{tension}} A_{AG}$$

$$20.33 = 20A_{AG}$$

$$A_{AG} = 1.17 \text{ in}^2 \rightarrow \text{answer}$$

For member BC (At section through MN):

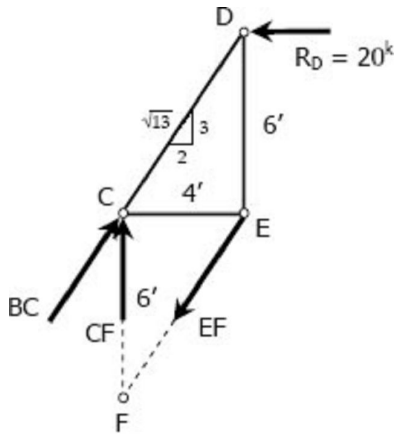

Section through MN

$$\Sigma M_F = 0$$

$$6\left(\frac{2}{\sqrt{13}}BC\right) = 12(20)$$

$$BC = 72.11^k \text{ Compression}$$

$$BC = \sigma_{\text{compression}} A_{BC}$$

$$72.11 = 14A_{BC}$$

$$A_{BC} = 5.15 \text{ in}^2 \rightarrow \text{answer}$$

For member CE (At joint D):

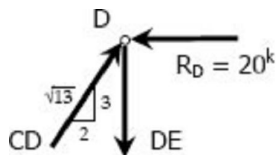

Joint D

$$\Sigma F_H = 0$$

$$\frac{2}{\sqrt{13}}CD = 20$$

$$CD = 36.06^k$$

$$\Sigma F_V = 0$$

$$DE = \frac{3}{\sqrt{13}}CD = \frac{3}{\sqrt{13}}(36.06) = 30^k$$

At joint E:

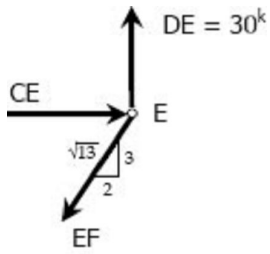

Joint E

$$\sum F_V = 0$$

$$\frac{3}{\sqrt{13}} EF = 30$$

$$EF = 36.06^k$$

$$\sum F_H = 0$$

$$CE = \frac{2}{\sqrt{13}} EF = \frac{2}{\sqrt{13}} (36.06) = 20^k \text{ Compression}$$

$$CF = \sigma_{\text{compression}} A_{CE}$$

$$20 = 14 A_{CE}$$

$$A_{CE} = 1.43 \text{ in}^2 \rightarrow \text{answer}$$

Solution to Problem 113 Normal Stress

Strength of Materials 4th Edition by Pytel and Singer

Given:

Cross sectional area of each member = 1600 mm^2 .

Required: Stresses in members BC, BD, and CF

Solution 113

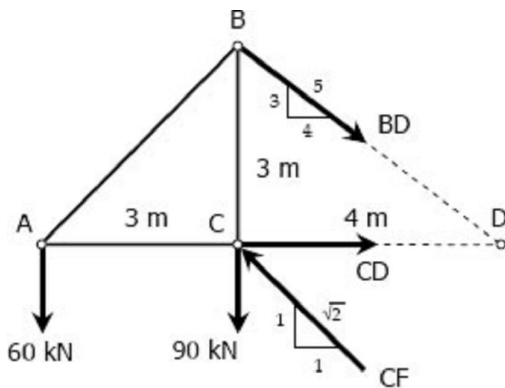

FBD 01

For member BD: (See FBD 01)

$$\sum M_C = 0$$

$$3\left(\frac{4}{5} BD\right) = 3(60)$$

$$BD = 75 \text{ kN Tension}$$

$$BD = \sigma_{BD}A$$

$$75(1000) = \sigma_{BD}(1600)$$

$$\sigma_{BD} = 46.875 \text{ MPa (Tension)} \rightarrow \text{answer}$$

For member CF: (See FBD 01)

$$\Sigma M_D = 0$$

$$4\left(\frac{1}{\sqrt{2}}CF\right) = 4(90) + 7(60)$$

$$CF = 275.77 \text{ kN Compression}$$

$$CF = \sigma_{CF} A$$

$$275.77(1000) = \sigma_{CF}(1600)$$

$$\sigma_{CF} = 172.357 \text{ MPa (Compression)} \rightarrow \text{answer}$$

For member BC: (See FBD 02)

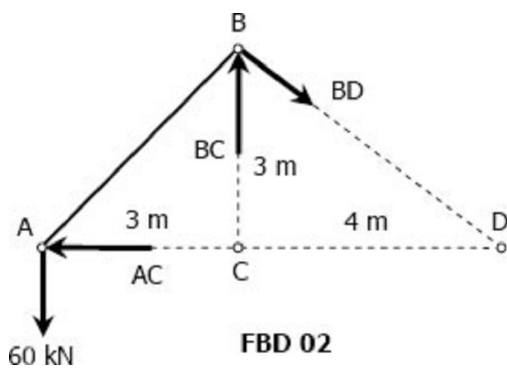

$$\Sigma M_D = 0$$

$$4BC = 7(60)$$

$$BC = 105 \text{ kN Compression}$$

$$BC = \sigma_{BC}A$$

$$105(1000) = \sigma_{BC}(1600)$$

$$\sigma_{BC} = 65.625 \text{ MPa (Compression)} \rightarrow \text{answer}$$

Solution to Problem 114 Normal Stress

Strength of Materials 4th Edition by Pytel and Singer

Given:

Maximum allowable stress in each cable = 100 MPa

Area of cable AB = 250 mm²

Area of cable at C = 300 mm²

Required: Mass of the heaviest bar that can be supported

Solution 114

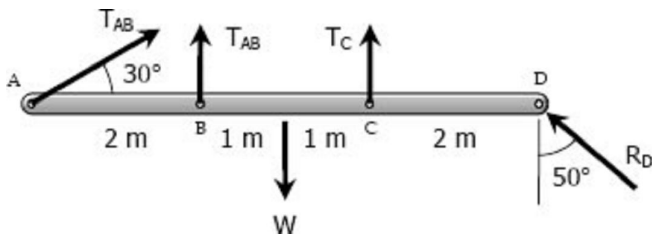

$$\Sigma F_H = 0$$

$$T_{AB} \cos 30^\circ = R_D \sin 50^\circ$$

$$R_D = 1.1305 T_{AB}$$

$$\Sigma F_V = 0$$

$$T_{AB} \sin 30^\circ + T_{AB} + T_C + R_D \cos 50^\circ = W$$

$$T_{AB} \sin 30^\circ + T_{AB} + T_C + (1.1305 T_{AB}) \cos 50^\circ = W$$

$$2.2267 T_{AB} + T_C = W$$

$$T_C = W - 2.2267 T_{AB}$$

$$\Sigma M_D = 0$$

$$6(T_{AB} \sin 30^\circ) + 4T_{AB} + 2T_C = 3W$$

$$7T_{AB} + 2(W - 2.2267 T_{AB}) = 3W$$

$$2.5466 T_{AB} = W$$

$$T_{AB} = 0.3927 W$$

$$T_C = W - 2.2267 T_{AB}$$

$$T_C = W - 2.2267(0.3927 W)$$

$$T_C = 0.1256 W$$

Based on cable AB:

$$T_{AB} = \sigma_{AB} A_{AB}$$

$$0.3927 W = 100(250)$$

$$W = 63661.83 \text{ N}$$

Based on cable at C:

$$T_2 = \sigma_C A_C$$

$$0.1256 W = 100(300)$$

$$W = 238853.50 \text{ N}$$

Safe weight $W = 63669.92 \text{ N}$

$$W = mg$$

$$63669.92 = m(9.81)$$

$$m = 6490 \text{ kg}$$

$$m = 6.49 \text{ Mg} \rightarrow \text{answer}$$

Shear Stress

Forces parallel to the area resisting the force cause shearing stress. It differs to tensile and compressive stresses, which are caused by forces perpendicular to the area on which they act. Shearing stress is also known as tangential stress.

$$\tau = \frac{V}{A}$$

where V is the resultant shearing force which passes through the centroid of the area A being sheared.

Solution to Problem 115 Shear Stress

Strength of Materials 4th Edition by Pytel and Singer

Given:

Required diameter of hole = 20 mm

Thickness of plate = 25 mm

Shear strength of plate = 350 MN/m²

Required: Force required to punch a 20-mm-diameter hole

Solution 115

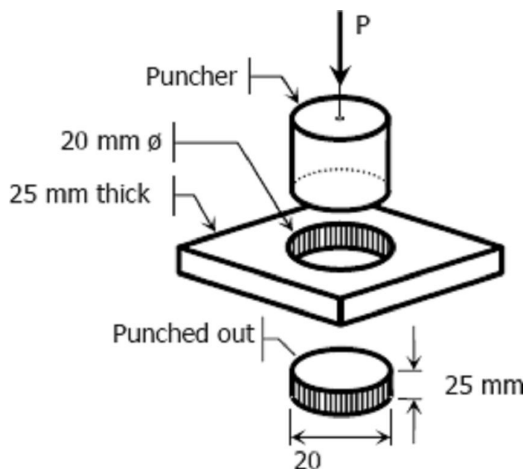

The resisting area is the shaded area along the perimeter and the shear force V is equal to the punching force P .

$$V = \tau A$$

$$P = 350 [\pi(20)(25)]$$

$$P = 549\,778.7 \text{ N}$$

$$P = 549.8 \text{ kN} \rightarrow \text{answer}$$

Solution to Problem 116 Shear Stress

Strength of Materials 4th Edition by Pytel and Singer

Given:

Shear strength of plate = 40 ksi

Allowable compressive stress of punch = 50 ksi

The figure below:

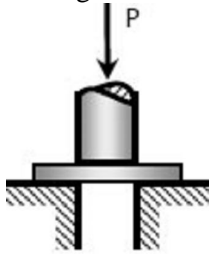

Figure 1-11c

Required:

- Maximum thickness of plate to punch a 2.5 inches diameter hole
- Diameter of smallest hole if the plate is 0.25 inch thick

Solution 116

- Maximum thickness of plate:**

Based on puncher strength:

$$P = \sigma A$$

$$P = 50 \left[\frac{1}{4} \pi (2.5)^2 \right]$$

$$P = 78.125\pi \text{ kips} \rightarrow \text{Equivalent shear force of the plate}$$

Based on shear strength of plate:

$$V = \tau A \rightarrow V = P$$

$$78.125\pi = 40 \left[\pi (2.5t) \right]$$

$$t = 0.781 \text{ inch} \rightarrow \text{answer}$$

- Diameter of smallest hole:**

Based on compression of puncher:

$$P = \sigma A$$

$$P = 50 \left(\frac{1}{4} \pi d^2 \right)$$

$$P = 12.5\pi d^2 \rightarrow \text{Equivalent shear force for plate}$$

Based on shearing of plate:

$$V = \tau A \rightarrow V = P$$

$$12.5\pi d^2 = 40 \left[\pi d (0.25) \right]$$

$$d = 0.8 \text{ in} \rightarrow \text{answer}$$

Solution to Problem 117 Shear Stress

Strength of Materials 4th Edition by Pytel and Singer**Given:**Force $P = 400 \text{ kN}$

Shear strength of the bolt = 300 MPa

The figure below:

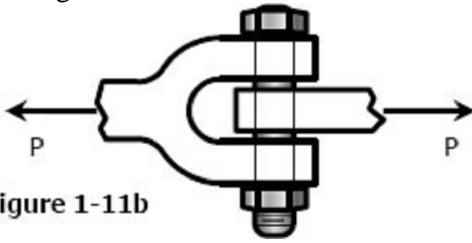

Figure 1-11b

Required: Diameter of the smallest bolt

Solution 117

The bolt is subject to double shear.

$$V = \tau A$$

$$400(1000) = 300 \left[2 \left(\frac{1}{4} \pi d^2 \right) \right]$$

$$d = 29.13 \text{ mm} \rightarrow \text{answer}$$

Solution to Problem 118 Shear Stress

Strength of Materials 4th Edition by Pytel and Singer

Given:

Diameter of pulley = 200 mm

Diameter of shaft = 60 mm

Length of key = 70 mm

Applied torque to the shaft = 2.5 kN · m

Allowable shearing stress in the key = 60 MPa

Required: Width b of the key

Solution 118

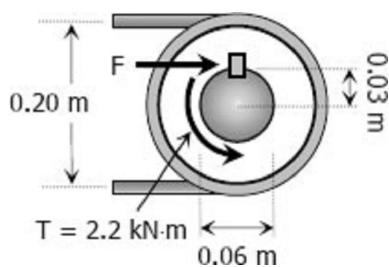

$$T = 0.03F$$

$$2.2 = 0.03F$$

$$F = 73.33 \text{ kN}$$

$$V = \tau A$$

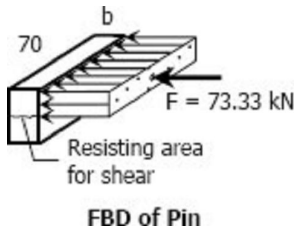

Where:

$$V = F = 73.33 \text{ kN}$$

$$A = 70b$$

$$\tau = 60 \text{ MPa}$$

$$73.33(1000) = 60(70b)$$

$$b = 17.46 \text{ mm} \rightarrow \text{answer}$$

Solution to Problem 119 Shear Stress

Strength of Materials 4th Edition by Pytel and Singer

Given:

Diameter of pin at B = 20 mm

Required: Shearing stress of the pin at B

Solution 119

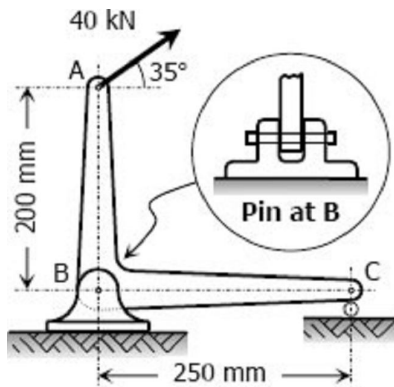

Figure P-119

From the FBD:

$$\sum M_C = 0$$

$$0.25R_{BV} = 0.25(40 \sin 35^\circ) + 0.2(40 \cos 35^\circ)$$

$$R_{BV} = 49.156 \text{ kN}$$

$$\sum F_H = 0$$

$$R_{BH} = 40 \cos 35^\circ$$

$$R_{BH} = 32.766 \text{ kN}$$

$$R_B = \sqrt{R_{BH}^2 + R_{BV}^2}$$

$$R_B = \sqrt{32.766^2 + 49.156^2}$$

$$R_B = 59.076 \text{ kN} \rightarrow \text{shear force of pin at B}$$

$$V_B = \tau_B A \rightarrow \text{double shear}$$

$$59.076(1000) = \tau_B \left\{ 2 \left[\frac{1}{4} \pi (20^2) \right] \right\}$$

$$\tau_B = 94.02 \text{ MPa} \rightarrow \text{answer}$$

Solution to Problem 120 Shear Stress

Strength of Materials 4th Edition by Pytel and Singer

Given:

Unit weight of each member = 200 lb/ft

Maximum shearing stress for pin at A = 5 000 psi

Required: The smallest diameter pin that can be used at A

Solution 120

For member AB:

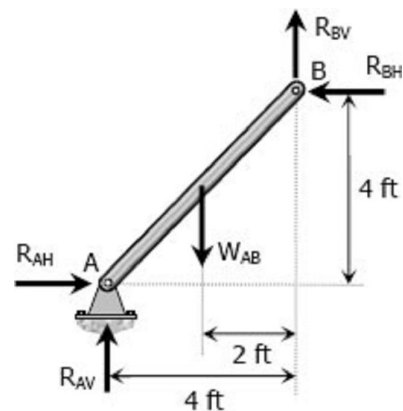

FBD of Member AB

$$\text{Length, } L_{AB} = \sqrt{4^2 + 4^2} = 5.66 \text{ ft}$$

$$\text{Weight, } W_{AB} = 5.66(200) = 1\,132 \text{ lb}$$

$$\Sigma M_A = 0$$

$$4R_{BH} + 4R_{BV} = 2W_{AB}$$

$$4R_{BH} + 4R_{BV} = 2(1132)$$

$$R_{BH} + R_{BV} = 566 \rightarrow \text{Equation (1)}$$

For member BC:

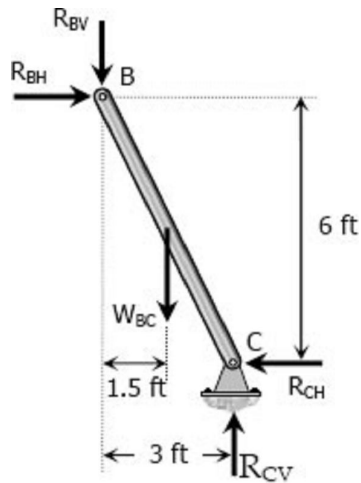

FBD of member BC

Length, $L_{BC} = \sqrt{3^2 + 6^2} = 6.71 \text{ ft}$
 Weight, $W_{BC} = 6.71(200) = W_{BC} = 1342 \text{ lb}$

$$\Sigma M_C = 0$$

$$6R_{BH} = 1.5W_{BC} + 3R_{BV}$$

$$6R_{BH} - 3R_{BV} = 1.5(1342)$$

$$2R_{BH} - R_{BV} = 671 \rightarrow \text{Equation (2)}$$

Add equations (1) and (2)

$$R_{BH} + R_{BV} = 566 \rightarrow \text{Equation (1)}$$

$$R_{BH} - R_{BV} = 671 \rightarrow \text{Equation (2)}$$

$$3R_{BH} + R_{BV} = 1237$$

$$R_{BH} = 412.33 \text{ lb}$$

From equation (1):

$$412.33 + R_{BV} = 566$$

$$R_{BV} = 153.67 \text{ lb}$$

From the FBD of member AB

$$\Sigma F_H = 0$$

$$R_{AH} = R_{BH} = 412.33 \text{ lb}$$

$$\Sigma F_V = 0$$

$$R_{AV} + R_{BV} = W_{AB}$$

$$R_{AV} + 153.67 = 1132$$

$$R_{AV} = 978.33 \text{ lb}$$

$$R_A = \sqrt{R_{AH}^2 + R_{AV}^2}$$

$$R_A = \sqrt{412.33^2 + 978.33^2}$$

$$R_A = 1061.67 \text{ lb} \rightarrow \text{shear force of pin at A}$$

$$V = \tau A$$

$$1061.67 = 5000\left(\frac{1}{4}\pi d^2\right)$$

$$d = 0.520 \text{ in} \rightarrow \text{answer}$$

Solution to Problem 121 Shear Stress

Strength of Materials 4th Edition by Pytel and Singer

Given:

Allowable shearing stress in the pin at B = 4000 psi

Allowable axial stress in the control rod at C = 5000 psi

Diameter of the pin = 0.25 inch

Diameter of control rod = 0.5 inch

Pin at B is at single shear

Required: The maximum force P that can be applied by the operator

Solution 121

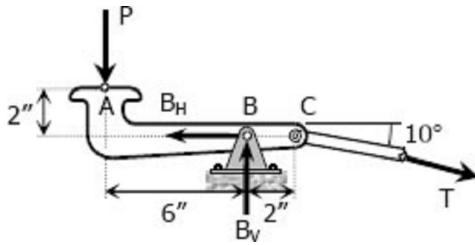

$$\Sigma M_B = 0$$

$$6P = 2T \sin 10^\circ \rightarrow \text{Equation (1)}$$

$$\Sigma F_H = 0$$

$$B_H = T \cos 10^\circ$$

$$\text{From Equation (1), } T = \frac{3P}{\sin 10^\circ}$$

$$B_H = \left(\frac{3P}{\sin 10^\circ} \right) \cos 10^\circ$$

$$B_H = 3 \cot 10^\circ P$$

$$\Sigma F_V = 0$$

$$B_V = T \sin 10^\circ + P$$

$$\text{From Equation (1), } T \sin 10^\circ = 3P$$

$$B_V = 3P + P$$

$$B_V = 4P$$

$$R_B^2 = B_H^2 + B_V^2$$

$$R_B^2 = (3 \cot 10^\circ P)^2 + (4P)^2$$

$$R_B^2 = 305.47P^2$$

$$R_B = 17.48P$$

$$P = \frac{R_B}{17.48} \rightarrow \text{Equation (2)}$$

Based on tension of rod (equation 1):

$$P = \frac{1}{3} T \sin 10^\circ$$

$$P = \frac{1}{3} [5000 \times \frac{1}{4} \pi (0.5)^2] \sin 10^\circ$$

$$P = 56.83 \text{ lb}$$

Based on shear of rivet (equation 2):

$$P = \frac{4000 [\frac{1}{4} \pi (0.25)^2]}{17.48}$$

$$P = 11.23 \text{ lb}$$

Safe load $P = 11.23 \text{ lb} \rightarrow \text{answer}$

Solution to Problem 122 Shear Stress

Strength of Materials 4th Edition by Pytel and Singer

Given:

Width of wood = w

Thickness of wood = t

Angle of Inclination of glued joint = θ

Cross sectional area = A

Required: Show that shearing stress on glued joint $\tau = P \sin 2\theta / 2A$

Solution 122

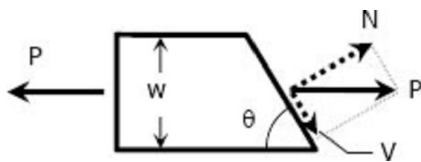

Shear area, $A_{\text{shear}} = t(w \csc \theta)$

Shear area, $A_{\text{shear}} = tw \csc \theta$

Shear area, $A_{\text{shear}} = A \csc \theta$

Shear force, $V = P \cos \theta$

$$V = \tau A_{\text{shear}}$$

$$P \cos \theta = \tau (A \csc \theta)$$

$$\tau = \frac{P \sin \theta \cos \theta}{A}$$

$$\tau = \frac{P(2 \sin \theta \cos \theta)}{2A}$$

$$\tau = P \sin 2\theta / 2A \text{ (ok!)}$$

Solution to Problem 123 Shear Stress

Strength of Materials 4th Edition by Pytel and Singer

Given:

Cross-section of wood = 50 mm by 100 mm

Maximum allowable compressive stress in wood = 20 MN/m^2

Maximum allowable shear stress parallel to the grain in wood = 5 MN/m^2

Inclination of the grain from the horizontal = 20 degree

Required: The axial force P that can be safely applied to the block

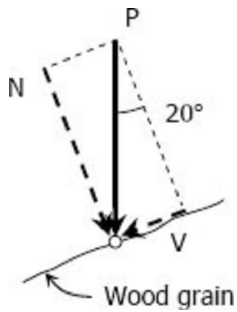
Solution 123**Based on maximum compressive stress:**

Normal force:

$$N = P \cos 20^\circ$$

Normal area:

$$A_N = 50(100 \sec 20^\circ)$$

$$A_N = 5320.89 \text{ mm}^2$$

$$N = \sigma A_N$$

$$P \cos 20^\circ = 20(5320.89)$$

$$P = 113\,247 \text{ N}$$

$$P = 113.25 \text{ kN}$$

Based on maximum shearing stress:

Shear force:

$$V = P \sin 20^\circ$$

Shear area:

$$A_V = A_N$$

$$A_V = 5320.89 \text{ mm}^2$$

$$V = \tau A_V$$

$$P \sin 20^\circ = 5(5320.89)$$

$$P = 77\,786 \text{ N}$$

$$P = 77.79 \text{ kN}$$

For safe compressive force, use $P = 77.79 \text{ kN} \rightarrow \text{answer}$

Bearing Stress

Bearing stress is the contact pressure between the separate bodies. It differs from compressive stress, as it is an internal stress caused by compressive forces.

$$\sigma_b = \frac{P_b}{A_b}$$

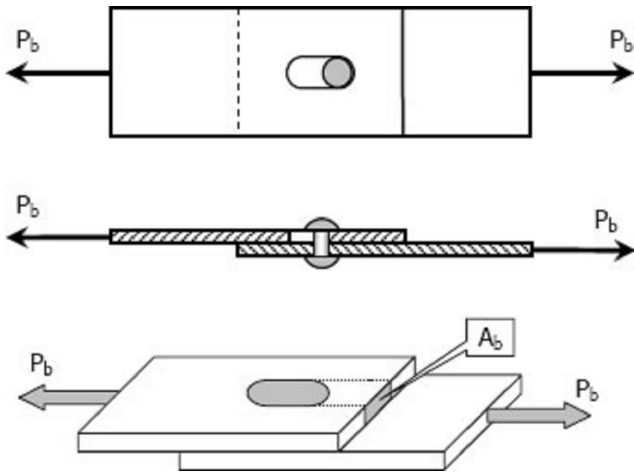

Solution to Problem 125 Bearing Stress

Problem 125

In Fig. 1-12, assume that a 20-mm-diameter rivet joins the plates that are each 110 mm wide. The allowable stresses are 120 MPa for bearing in the plate material and 60 MPa for shearing of rivet. Determine (a) the minimum thickness of each plate; and (b) the largest average tensile stress in the plates.

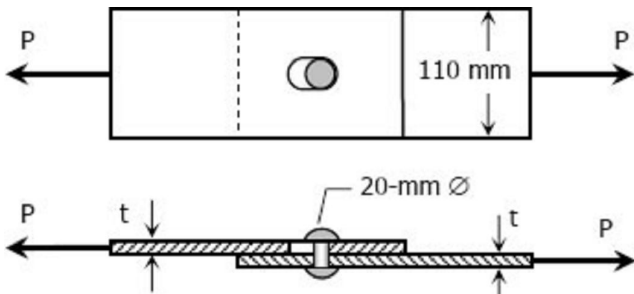

Figure 1-12

Solution 125

Part (a):

From shearing of rivet:

$$P = \tau A_{rivets}$$

$$P = 60 \left[\frac{1}{4} \pi (20)^2 \right]$$

$$P = 6000\pi \text{ textN}$$

From bearing of plate material:

$$P = \sigma_b A_b$$

$$6000\pi = 120(20t)$$

$$t = 7.85 \text{ mm} \rightarrow \text{answer}$$

Part (b): Largest average tensile stress in the plate:

$$P = \sigma A$$

$$6000\pi = \sigma[7.85(110-20)]$$

$$\sigma = 26.67 \text{ MPa} \rightarrow \text{answer}$$

Solution to Problem 126 Bearing Stress

Strength of Materials 4th Edition by Pytel and Singer

Given:

Diameter of each rivet = 3/4 inch

Maximum allowable shear stress of rivet = 14 ksi

Maximum allowable bearing stress of plate = 18 ksi

The figure below:

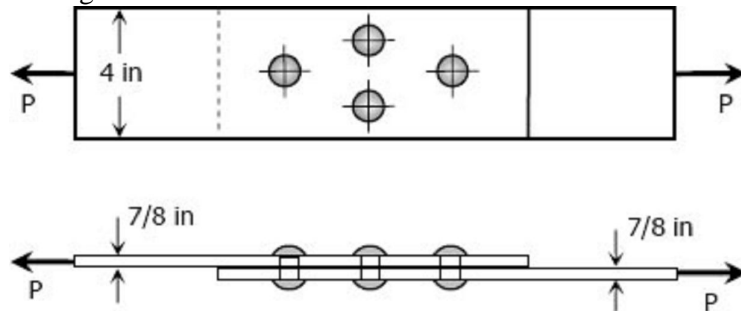

Figures P-126

Required: The maximum safe value of P that can be applied

Solution 126

Based on shearing of rivets:

$$P = \tau A$$

$$P = 14[4(\frac{1}{4}\pi)(\frac{3}{4})^2]$$

$$P = 24.74 \text{ kips}$$

Based on bearing of plates:

$$P = \sigma_b A_b$$

$$P = 18[4(\frac{3}{4})(\frac{7}{8})]$$

$$P = 47.25 \text{ kips}$$

Safe load $P = 24.74 \text{ kips} \rightarrow \text{answer}$

Solution to Problem 127 Bearing Stress

Strength of Materials 4th Edition by Pytel and Singer

Given:

Load $P = 14$ kips

Maximum shearing stress = 12 ksi

Maximum bearing stress = 20 ksi

The figure below:



Figure 1-11b

Required: Minimum bolt diameter and minimum thickness of each yoke

Solution 127

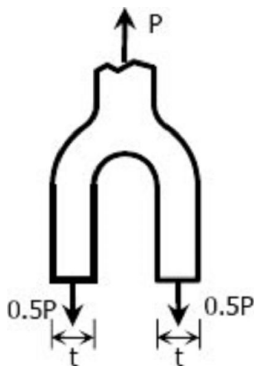

For shearing of rivets (double shear)

$$P = \tau A$$

$$14 = 12 \left[2 \left(\frac{1}{4} \pi d^2 \right) \right]$$

$$d = 0.8618 \text{ in} \rightarrow \text{diameter of bolt } \textit{answer}$$

For bearing of yoke:

$$P = \sigma_b A_b$$

$$14 = 20 \left[2(0.8618t) \right]$$

$$t = 0.4061 \text{ in} \rightarrow \text{thickness of yoke } \textit{answer}$$

Solution to Problem 128 Bearing Stress

Strength of Materials 4th Edition by Pytel and Singer

Given:

Shape of beam = W18 × 86
 Shape of girder = W24 × 117
 Shape of angles = 4 × 3-½ × 3/8
 Diameter of rivets = 7/8 inch
 Allowable shear stress = 15 ksi
 Allowable bearing stress = 32 ksi

Required: Allowable load on the connection

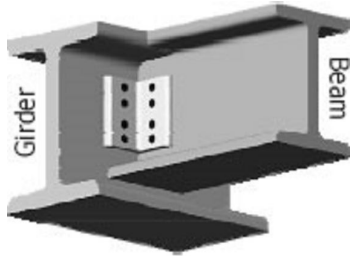

Figure 1-13

Solution 128

Relevant data from the table (Appendix B of textbook): Properties of Wide-Flange Sections (W shapes): U.S. Customary Units

Designation Web thickness

W18 × 86 0.480 in

W24 × 117 0.550 in

Shearing strength of rivets:

There are 8 single-shear rivets in the girder and 4 double-shear (equivalent to 8 single-shear) in the beam, thus, the shear strength of rivets in girder and beam are equal.

$$V = \tau A = 15 \left[\frac{1}{4} \pi \left(\frac{7}{8} \right)^2 (8) \right]$$

$$V = 72.16 \text{ kips}$$

Bearing strength on the girder:

The thickness of girder W24 × 117 is 0.550 inch while that of the angle clip $L4 \times 3\frac{1}{2} \times \frac{3}{8}$ is $\frac{3}{8}$ or 0.375 inch, thus, the critical in bearing is the clip.

$$P = \sigma_b A_b = 32 \left[\frac{7}{8} (0.375) (8) \right]$$

$$P = 84 \text{ kips}$$

Bearing strength on the beam:

The thickness of beam W18 × 86 is 0.480 inch while that of the clip angle is $2 \times 0.375 = 0.75$ inch (clip angles are on both sides of the beam), thus, the critical in bearing is the beam.

$$P = \sigma_b A_b = 32 \left[\frac{7}{8} (0.480) (4) \right]$$

$$P = 53.76 \text{ kips}$$

The allowable load on the connection is $P = 53.76 \text{ kips} \rightarrow \text{answer}$

Solution to Problem 129 Bearing Stress

Strength of Materials 4th Edition by Pytel and Singer

Given:

Diameter of bolt = 7/8 inch

Diameter at the root of the thread (bolt) = 0.731 inch

Inside diameter of washer = 9/8 inch

Tensile stress in the nut = 18 ksi

Bearing stress = 800 psi

Required:

Shearing stress in the head of the bolt

Shearing stress in threads of the bolt

Outside diameter of the washer

Solution 129

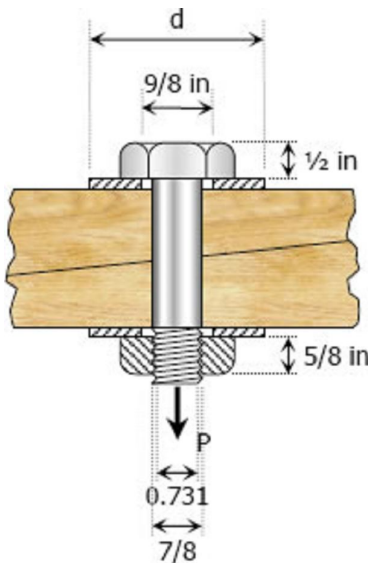

Tensile force on the bolt:

$$P = \sigma A = 18 \left[\frac{1}{4} \pi \left(\frac{7}{8} \right)^2 \right]$$

$$P = 10.82 \text{ kips}$$

Shearing stress in the head of the bolt:

$$\tau = \frac{P}{A} = \frac{10.82}{\pi \left(\frac{7}{8} \right) \left(\frac{1}{2} \right)}$$

$$\tau = 7.872 \text{ ksi} \rightarrow \text{answer}$$

Shearing stress in the threads:

$$\tau = \frac{P}{A} = \frac{10.82}{\pi (0.731) \left(\frac{5}{8} \right)}$$

$$\tau = 7.538 \text{ ksi} \rightarrow \text{answer}$$

Outside diameter of washer:

$$P = \sigma_b A_b$$

$$10.82(1000) = 800 \left\{ \frac{1}{4} \pi \left[d^2 - \left(\frac{9}{8} \right)^2 \right] \right\}$$

$$d = 4.3 \text{ inch} \rightarrow \text{answer}$$

Solution to Problem 130 Bearing Stress

Strength of Materials 4th Edition by Pytel and Singer

Given:

- Allowable shear stress = 70 MPa
- Allowable bearing stress = 140 MPa
- Diameter of rivets = 19 mm
- The truss below:

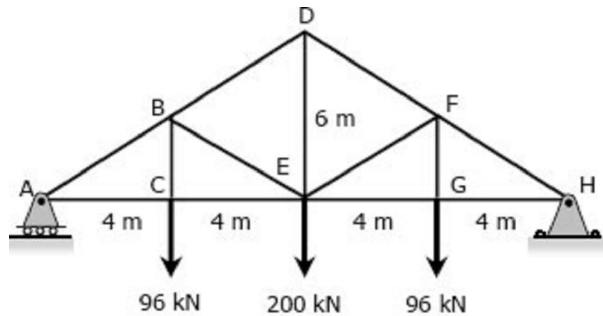

Figure P-130 and P-131

Required:

- Number of rivets to fasten member BC to the gusset plate
- Number of rivets to fasten member BE to the gusset plate
- Largest average tensile or compressive stress in members BC and BE

Solution 130

At Joint C:

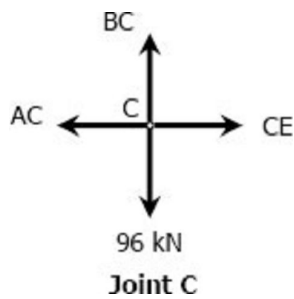

$$\sum F_v = 0$$

$$BC = 96 \text{ kN (Tension)}$$

Consider the section through member BD, BE, and CE:

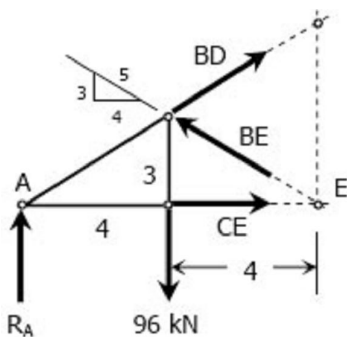

Section through BD, BE, and CE

$$\Sigma M_A = 0$$

$$8\left(\frac{3}{5}BE\right) = 4(96)$$

$$BE = 80 \text{ kN (Compression)}$$

For Member BC:

Based on shearing of rivets:

$$BC = \tau A \text{ Where } A = \text{area of 1 rivet} \times \text{number of rivets, } n$$

$$96\,000 = 70\left[\frac{1}{4}\pi(19^2)n\right]$$

$$n = 4.8 \text{ say 5 rivets}$$

Based on bearing of member:

$$BC = \sigma_b A_b$$

Where $A_b = \text{diameter of rivet} \times \text{thickness of BC} \times \text{number of rivets, } n$

$$96\,000 = 140[19(6)n]$$

$$n = 6.02 \text{ say 7 rivets}$$

use 7 rivets for member BC *answer*

For member BE:

Based on shearing of rivets:

$$BE = \tau A$$

Where $A = \text{area of 1 rivet} \times \text{number of rivets, } n$

$$80\,000 = 70\left[\frac{1}{4}\pi(19^2)n\right]$$

$$n = 4.03 \text{ say 5 rivets}$$

Based on bearing of member:

$$BE = \sigma_b A_b$$

Where $A_b = \text{diameter of rivet} \times \text{thickness of BE} \times \text{number of rivets, } n$

$$80\,000 = 140[19(13)n]$$

$$n = 2.3 \text{ say 3 rivets}$$

use 5 rivets for member BE *answer*

Relevant data from the table (Appendix B of textbook): *Properties of Equal Angle Sections: SI Units*

Designation	Area
L75 × 75 × 6	864 mm ²
L75 × 75 × 13	1780 mm ²

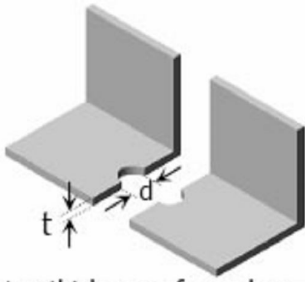

t = thickness of member
d = diameter of rivet hole

Note:

A = Area – dt

Tensile stress of member BC (L75 × 75 × 6):

$$\sigma = \frac{P}{A} = \frac{96(1000)}{864 - 19(6)}$$

$$\sigma = 128 \text{ Mpa} \rightarrow \text{answer}$$

Compressive stress of member BE (L75 × 75 × 13):

$$\sigma = \frac{P}{A} = \frac{80(1000)}{1780}$$

$$\sigma = 44.94 \text{ Mpa} \rightarrow \text{answer}$$

Solution to Problem 131 Bearing Stress

Repeat [Problem 130](#) if the rivet diameter is 22 mm and all other data remain unchanged.

Solution 131

For member BC:

$$P = 96 \text{ kN (Tension)}$$

Based on shearing of rivets:

$$P = \tau A$$

$$96\,000 = 70 \left[\frac{1}{4} \pi (22^2) n \right]$$

$$n = 3.6 \text{ say } 4 \text{ rivets}$$

Based on bearing of member:

$$P = \sigma_b A_b$$

$$96\,000 = 140 [22(6)n]$$

$$n = 5.2 \text{ say } 6 \text{ rivets}$$

Use 6 rivets for member BC *answer*

Tensile stress:

$$\sigma = \frac{P}{A} = \frac{96(1000)}{864 - 22(6)}$$

$$\sigma = 131.15 \text{ MPa} \rightarrow \text{answer}$$

For member BE:

$$P = 80 \text{ kN (Compression)}$$

Based on shearing of rivets:

$$P = \tau A$$

$$80\,000 = 70 \left[\frac{1}{4} \pi (22^2) n \right]$$

$$n = 3.01 \text{ say 4 rivets}$$

Based on bearing of member:

$$P = \sigma_b A_b$$

$$80\,000 = 140 [22(13)n]$$

$$n = 1.998 \text{ say 2 rivets}$$

use 4 rivets for member BE *answer*

Compressive stress:

$$\sigma = \frac{P}{A} = \frac{80(1000)}{1780}$$

$$\sigma = 44.94 \text{ MPa} \rightarrow \textit{answer}$$

Thin-walled Pressure Vessels

A tank or pipe carrying a fluid or gas under a pressure is subjected to tensile forces, which resist bursting, developed across longitudinal and transverse sections.

TANGENTIAL STRESS (Circumferential Stress)

Consider the tank shown being subjected to an internal pressure p . The length of the tank is L and the wall thickness is t . Isolating the right half of the tank:

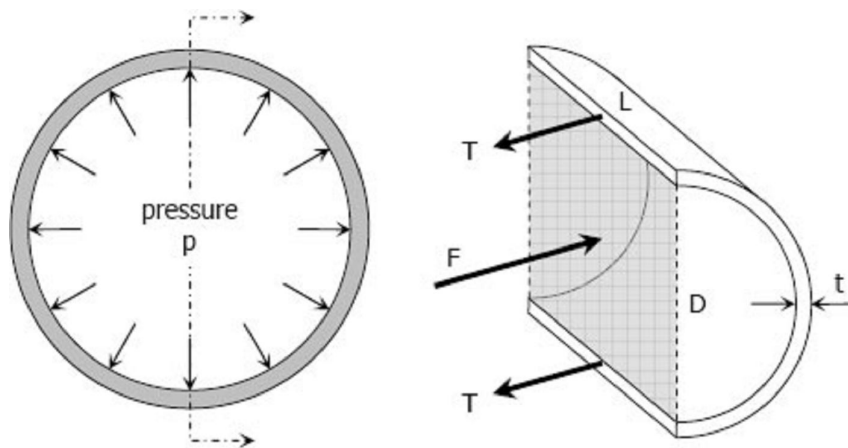

The forces acting are the total pressures caused by the internal pressure p and the total tension in the walls T .

$$F = pA = pDL$$

$$T = \sigma_t A_{wall} = \sigma_t tL$$

$$\Sigma F_H = 0$$

$$F = 2T$$

$$pDL = 2(\sigma_t tL)$$

$$\sigma_t = \frac{pD}{2t}$$

If there exist an external pressure p_o and an internal pressure p_i , the formula may be expressed as:

$$\sigma_t = \frac{(p_i - p_o)D}{2t}$$

LONGITUDINAL STRESS, σ_L

Consider the free body diagram in the transverse section of the tank:

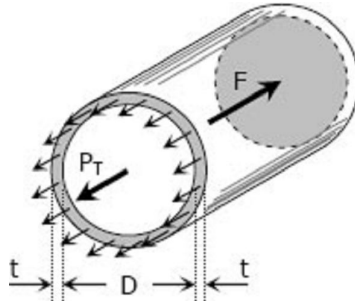

The total force acting at the rear of the tank F must equal to the total longitudinal stress on the wall

$P_T = \sigma_L A_{wall}$. Since t is so small compared to D , the area of the wall is close to πDt

$$F = pA = p \frac{\pi}{4} D^2$$

$$P_T = \sigma_L \pi Dt$$

$$\Sigma F_H = 0$$

$$P_T = F$$

$$\sigma_L \pi Dt = p \frac{\pi}{4} D^2$$

$$\sigma_t = \frac{pD}{4t}$$

If there exist an external pressure p_o and an internal pressure p_i , the formula may be expressed as:

$$\sigma_t = \frac{(p_i - p_o)D}{4t}$$

It can be observed that the tangential stress is twice that of the longitudinal stress.

$$\sigma_t = 2\sigma_L$$

SPHERICAL SHELL

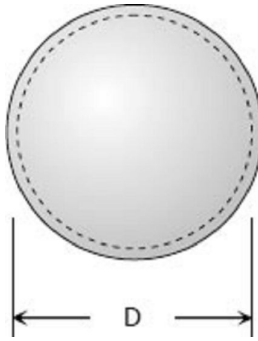

If a spherical tank of diameter D and thickness t contains gas under a pressure of p , the stress at the wall can be expressed as:

$$\sigma_t = \frac{(p_i - p_o)D}{4t}$$

Solution to Problem 133 Pressure Vessel

Strength of Materials 4th Edition by Pytel and Singer

Given:

Diameter of cylindrical pressure vessel = 400 mm

Wall thickness = 20 mm

Internal pressure = 4.5 MN/m²

Allowable stress = 120 MN/m²

Required:

Longitudinal stress

Tangential stress

Maximum amount of internal pressure that can be applied

Expected fracture if failure occurs

Solution 133

Part (a)

Tangential stress (longitudinal section):

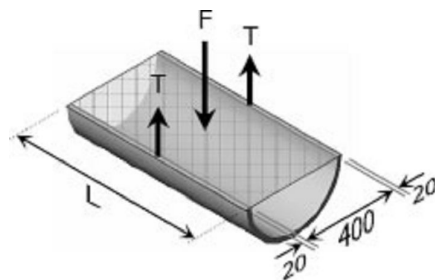

Longitudinal Section

$$F = 2T$$

$$pDL = 2(\sigma_t t L)$$

$$\sigma_t = \frac{pD}{2t} = \frac{4.5(400)}{2(20)}$$

$$\sigma_t = 45 \text{ MPa} \rightarrow \text{answer}$$

Longitudinal Stress (transverse section):

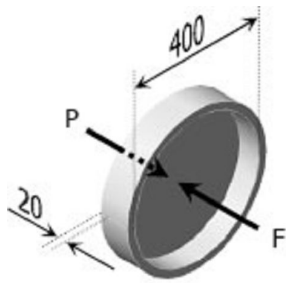

Transverse Section

$$F = P$$

$$\frac{1}{4}\pi D^2 p = \sigma_l(\pi D t)$$

$$\sigma_l = \frac{pD}{4t} = \frac{4.5(400)}{4(20)}$$

$$\sigma_l = 22.5 \text{ MPa} \rightarrow \text{answer}$$

Part (b)

From (a), $\sigma_t = \frac{pD}{2t}$ and $\sigma_l = \frac{pD}{4t}$ thus, $\sigma_t = 2\sigma_l$, this shows that tangential stress is the critical.

$$\sigma_t = \frac{pD}{2t}$$

$$120 = \frac{p(400)}{2(20)}$$

$$p = 12 \text{ MPa} \rightarrow \text{answer}$$

The bursting force will cause a stress on the longitudinal section that is twice to that of the transverse section. Thus, fracture is expected as shown.

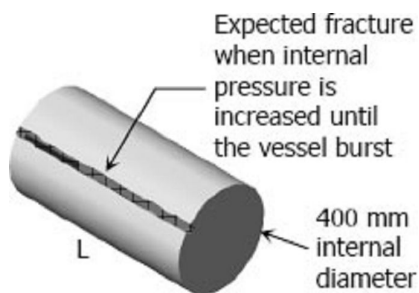

Solution to Problem 134 Pressure Vessel

Strength of Materials 4th Edition by Pytel and Singer

Given:

Diameter of spherical tank = 4 ft

Wall thickness = 5/16 inch

Maximum stress = 8000 psi

Required: Allowable internal pressure

Solution 134

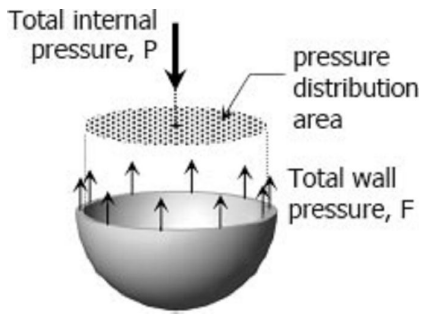

Total internal pressure:

$$P = p\left(\frac{1}{4}\pi D^2\right)$$

Resisting wall:

$$F = P$$

$$\sigma A = p\left(\frac{1}{4}\pi D^2\right)$$

$$\sigma(\pi Dt) = p\left(\frac{1}{4}\pi D^2\right)$$

$$\sigma = \frac{pD}{4t}$$

$$8000 = \frac{p(4 \times 12)}{4\left(\frac{5}{16}\right)}$$

$$p = 208.33 \text{ psi} \rightarrow \text{answer}$$

Solution to Problem 135 Pressure Vessel

Problem 135

Calculate the minimum wall thickness for a cylindrical vessel that is to carry a gas at a pressure of 1400 psi. The diameter of the vessel is 2 ft, and the stress is limited to 12 ksi.

Solution 135

The critical stress is the tangential stress

$$\sigma_t = \frac{pD}{2t}$$

$$12\,000 = \frac{1400(2 \times 12)}{2t}$$

$$t = 1.4 \text{ in} \rightarrow \text{answer}$$

Solution to Problem 136 Pressure Vessel

Strength of Materials 4th Edition by Pytel and Singer

Given:

Thickness of steel plating = 20 mm
 Diameter of pressure vessel = 450 mm
 Length of pressure vessel = 2.0 m
 Maximum longitudinal stress = 140 MPa
 Maximum circumferential stress = 60 MPa

Required: The maximum internal pressure that can be applied

Solution 136

Based on circumferential stress (tangential):

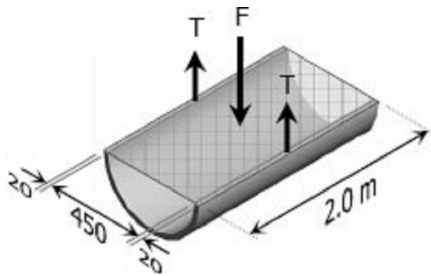

$$\Sigma F_V = 0$$

$$F = 2T$$

$$p(DL) = 2(\sigma_t L_t)$$

$$\sigma_t = \frac{pD}{2t}$$

$$60 = \frac{p(450)}{2(20)}$$

$$p = 5.33 \text{ MPa}$$

Based on longitudinal stress:

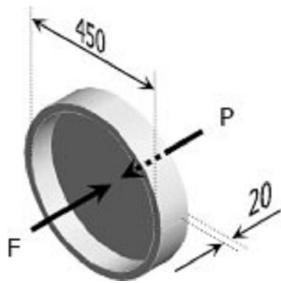

$$\Sigma F_H = 0$$

$$F = P$$

$$p\left(\frac{1}{4}\pi D^2\right) = \sigma_l(\pi D t)$$

$$\sigma_l = \frac{pD}{4t}$$

$$140 = \frac{p(450)}{4(20)}$$

$$p = 24.89 \text{ MPa}$$

Use $p = 5.33 \text{ MPa} \rightarrow \text{answer}$

Solution to Problem 137 Pressure Vessel

Strength of Materials 4th Edition by Pytel and Singer

Given:

- Diameter of the water tank = 22 ft
- Thickness of steel plate = 1/2 inch
- Maximum circumferential stress = 6000 psi
- Specific weight of water = 62.4 lb/ft³

Required: The maximum height to which the tank may be filled with water.

Solution 137

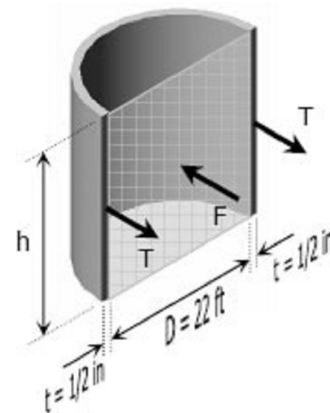
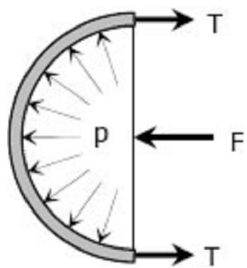

$$\sigma_t = 6000 \text{ psi} = 6000 \text{ lb/in}^2 (12 \text{ in/ft})^2$$

$$\sigma_t = 864\,000 \text{ lb/ft}^2$$

Assuming pressure distribution to be uniform:

$$p = \gamma h = 62.4h$$

$$F = pA = 62.4h(Dh)$$

$$F = 62.4(22)h^2$$

$$F = 1372.8h^2$$

$$T = \sigma_t A_t = 864\,000(th)$$

$$T = 864\,000\left(\frac{1}{2} \times \frac{1}{12}\right)h$$

$$T = 36\,000h$$

$$\Sigma F = 0$$

$$F = 2T$$

$$1372.8h^2 = 2(36\,000h)$$

$$h = 52.45 \text{ ft} \rightarrow \text{answer}$$

COMMENT

Given a free surface of water, the actual pressure distribution on the vessel is not uniform. It varies linearly from 0 at the free surface to γh at the bottom (see figure below). Using this actual pressure distribution, the total hydrostatic pressure is reduced by 50%. This reduction of force will take our design into critical situation; giving us a maximum height of 200% more than the h above.

Based on actual pressure distribution:

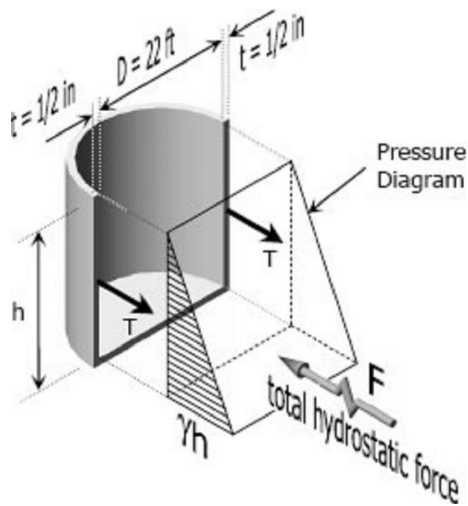

Total hydrostatic force, F :

$F = \text{volume of pressure diagram}$

$$F = \frac{1}{2}(\gamma h^2)D = \frac{1}{2}(62.4h^2)(22)$$

$$F = 686.4h^2$$

$$\Sigma M_A = 0$$

$$2T\left(\frac{1}{2}h\right) - F\left(\frac{1}{3}h\right) = 0$$

$$T = \frac{1}{3}F$$

$$\sigma_t(ht) = \frac{1}{3}(686.4h^2)$$

$$h = \frac{3\sigma_t t}{686.4} = \frac{3(864000)\left(\frac{1}{2} \times \frac{1}{12}\right)}{686.4}$$

$$h = 157.34 \text{ ft}$$

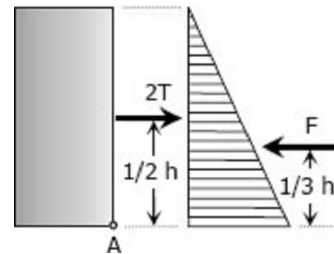

Solution to Problem 138 Pressure Vessel

Strength of Materials 4th Edition by Pytel and Singer

Given:

Strength of longitudinal joint = 33 kips/ft

Strength of girth joint = 16 kips/ft

Internal pressure = 150 psi

Required: Maximum diameter of the cylinder tank

Solution 138

For longitudinal joint (tangential stress):

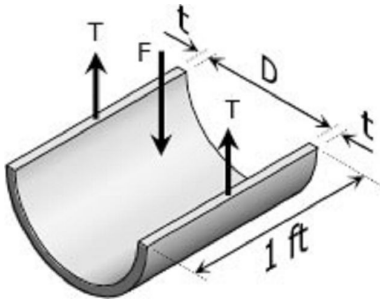

Consider 1 ft length

$$F = 2T$$

$$pD = 2\sigma_t t$$

$$\sigma_t = \frac{pD}{2t}$$

$$\frac{33\,000}{t} = \frac{21\,600D}{2t}$$

$$D = 3.06 \text{ ft} = 36.67 \text{ in.}$$

For girth joint (longitudinal stress):

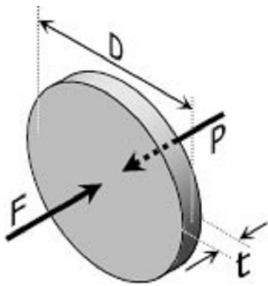

$$F = P$$

$$p\left(\frac{1}{4}\pi D^2\right) = \sigma_l(\pi D t)$$

$$\sigma_l = \frac{pD}{4t}$$

$$\frac{16\,000}{t} = \frac{21\,600D}{4t}$$

$$D = 2.96 \text{ ft} = 35.56 \text{ in.}$$

Use the smaller diameter, $D = 35.56 \text{ in.}$ *answer*

Solution to Problem 139 Pressure Vessel

Strength of Materials 4th Edition by Pytel and Singer

Given:

Allowable stress = 20 ksi

Weight of steel = 490 lb/ft³

Mean radius of the ring = 10 inches

Required:

The limiting peripheral velocity.
 The number of revolution per minute for stress to reach 30 ksi.

Solution 139

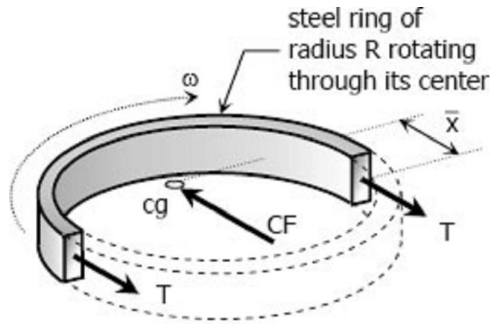

FBD of Ring in Rotation

Centrifugal Force, CF:

$$CF = M \omega^2 \bar{x}$$

where:

$$M = \frac{W}{g} = \frac{\gamma V}{g} = \frac{\gamma \pi R A}{g}$$

$$\omega = v/R$$

$$\bar{x} = 2R/\pi$$

$$CF = \frac{\gamma \pi R A}{g} \left(\frac{v}{R}\right)^2 \left(\frac{2R}{\pi}\right)$$

$$CF = \frac{2\gamma A v^2}{g}$$

$$2T = CF$$

$$2\gamma A = \frac{2\gamma A v^2}{g}$$

$$\sigma = \frac{\gamma v^2}{g}$$

From the given data:

$$\sigma = 20 \text{ ksi} = (20\,000 \text{ lb/in}^2)(12 \text{ in/ft})^2 a^2$$

$$\sigma = 2\,880\,000 \text{ lb/ft}^2$$

$$\gamma = 490 \text{ lb/ft}^3$$

$$2\,880\,000 = \frac{490 v^2}{32.2}$$

$$v = 435.04 \text{ ft/sec} \rightarrow \text{answer}$$

When $\sigma = 30 \text{ ksi}$, and $R = 10 \text{ in}$

$$\sigma = \frac{\gamma v^2}{g}$$

$$30\,000(12^2) = \frac{490v^2}{32.2}$$

$$v = 532.81 \text{ ft/sec}$$

$$\omega = v/R = \frac{532.81}{10/12}$$

$$\omega = 639.37 \text{ rad/sec}$$

$$\omega = \frac{639.37 \text{ rad}}{\text{sec}} \times \frac{1 \text{ rev}}{2\pi \text{ rad}} \times \frac{60 \text{ sec}}{1 \text{ min}}$$

$$\omega = 6,105.54 \text{ rpm} \rightarrow \text{answer}$$

Solution to Problem 140 Pressure Vessel

Strength of Materials 4th Edition by Pytel and Singer

Given:

Stress in rotating steel ring = 150 MPa

Mean radius of the ring = 220 mm

Density of steel = 7.85 Mg/m³

Required: Angular velocity of the steel ring

Solution 140

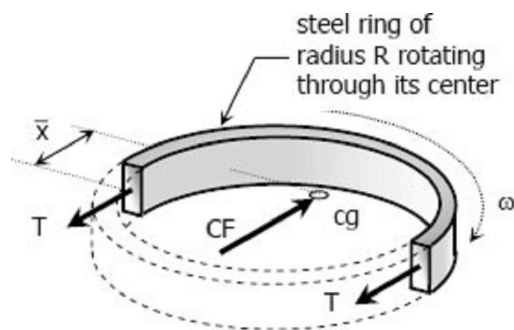

FBD of Ring in Rotation

$$CF = M\omega^2 \bar{x}$$

Where:

$$M = \rho V = \rho A \pi R$$

$$x = 2R/\pi$$

$$CF = \rho A \pi R \omega^2 (2R/\pi)$$

$$CF = 2\rho A R^2 \omega^2$$

$$2T = CF$$

$$2\sigma A = 2\rho AR^2\omega^2$$

$$\sigma = \rho R^2\omega^2$$

From the given (Note: $1 \text{ N} = 1 \text{ kg} \cdot \text{m}/\text{sec}^2$):

$$\sigma = 150 \text{ MPa}$$

$$\sigma = 150\,000\,000 \text{ kg} \cdot \text{m}/\text{sec}^2 \cdot \text{m}^2$$

$$\sigma = 150\,000\,000 \text{ kg}/\text{m} \cdot \text{sec}^2$$

$$\rho = 7.85 \text{ Mg}/\text{m}^3 = 7850 \text{ kg}/\text{m}^3$$

$$R = 220 \text{ mm} = 0.22 \text{ m}$$

$$150\,000\,000 = 7850(0.22)^2 \omega^2$$

$$\omega = 628.33 \text{ rad}/\text{sec} \rightarrow \text{answer}$$

Solution to Problem 141 Pressure Vessel

Strength of Materials 4th Edition by Pytel and Singer

Given:

Wall thickness = $1/8$ inch

Internal pressure = 125 psi

The figure below:

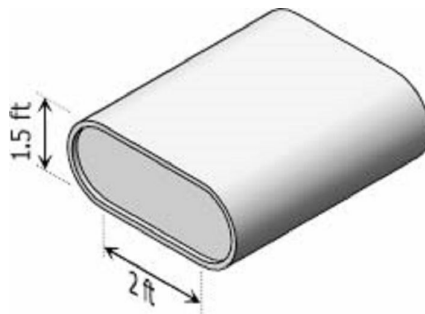
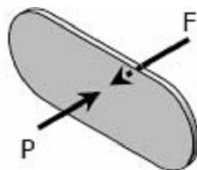

Figure P-141

Required: Maximum longitudinal and circumferential stress

Solution 141

Longitudinal Stress:



See dimensions in Fig. P-141,
thickness, $t = 1/8$ in.

$$F = pA = 125[1.5(2) + \frac{1}{4}\pi(1.5)^2](12^2)$$

$$F = 85\,808.62 \text{ lbs}$$

$$P = F$$

$$\sigma_t [2(2 \times 12)(\frac{1}{8}) + \pi(1.5 \times 12)(\frac{1}{8})] = 85\,808.62$$

$$\sigma_t = 6\,566.02 \text{ psi}$$

$$\sigma_t = 6.57 \text{ ksi} \rightarrow \text{answer}$$

Circumferential Stress:

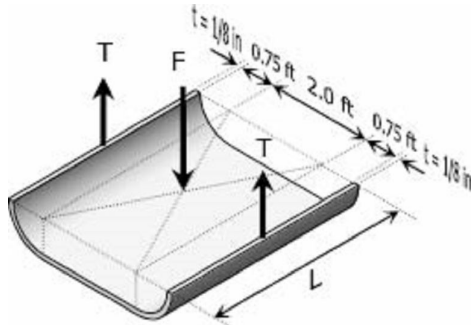

$$F = pA = 125 [(2 \times 12)L + 2(0.75 \times 12)L]$$

$$F = 5250L \text{ textlbs}$$

$$2T = F$$

$$2 [\sigma_t (\frac{1}{8})L] = 5250L$$

$$\sigma_t = 21\,000 \text{ psi}$$

$$\sigma_t = 21 \text{ ksi} \rightarrow \text{answer}$$

Solution to Problem 142 Pressure Vessel

Strength of Materials 4th Edition by Pytel and Singer

Given:

Steam pressure = 3.5 Mpa

Outside diameter of the pipe = 450 mm

Wall thickness of the pipe = 10 mm

Diameter of the bolt = 40 mm

Allowable stress of the bolt = 80 MPa

Initial stress of the bolt = 50 MPa

Required:

Number of bolts

Circumferential stress developed in the pipe

Solution 29

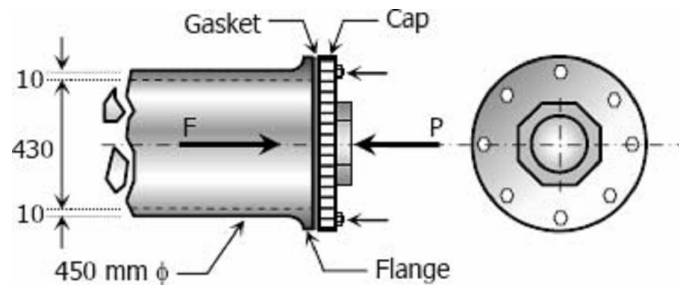

$$F = \sigma A$$

$$F = 3.5 \left[\frac{1}{4} \pi (430)^2 \right]$$

$$F = 508\,270.42 \text{ N}$$

$$P = F$$

$$(\sigma_{\text{bolt}} A) n = 508\,270.42 \text{ N}$$

$$(80 - 55) \left[\frac{1}{4} \pi (40)^2 \right] n = 508\,270.42$$

$$n = 16.19 \text{ say } 17 \text{ bolts} \rightarrow \text{answer}$$

Circumferential stress (consider 1-m strip):

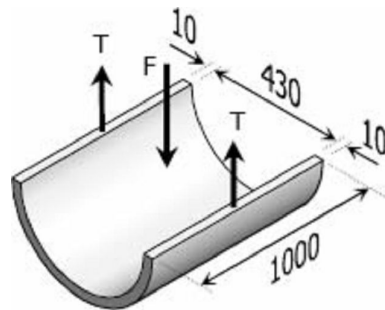

$$F = pA = 3.5 [430(1000)]$$

$$F = 1\,505\,000 \text{ N}$$

$$2T = F$$

$$2[\sigma_t(1000)(10)] = 1\,505\,000$$

$$\sigma_t = 75.25 \text{ MPa} \rightarrow \text{answer}$$

Discussion:

It is necessary to tighten the bolts initially to press the gasket to the flange, to avoid leakage of steam. If the pressure will cause 110 MPa of stress to each bolt causing it to fail, leakage will occur. If this is sudden, the cap may blow.

Chapter 2 - Strain

1. Simple Strain
2. Stress-Strain Diagram
3. Axial Deformation
4. Shearing Deformation
5. Poisson's Ratio

- 6. Statically Indeterminate Members
- 7. Thermal Stress

Simple Strain

Also known as unit deformation, strain is the ratio of the change in length caused by the applied force, to the original length.

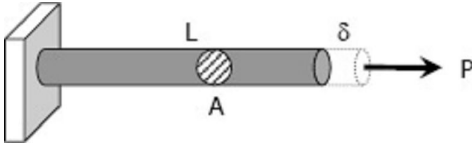

$$\epsilon = \frac{\delta}{L}$$

where δ is the deformation and L is the original length, thus ϵ is dimensionless.

Stress-strain Diagram

Suppose that a metal specimen be placed in tension-compression-testing machine. As the axial load is gradually increased in increments, the total elongation over the gauge length is measured at each increment of the load and this is continued until failure of the specimen takes place. Knowing the original cross-sectional area and length of the specimen, the normal stress σ and the strain ϵ can be obtained. The graph of these quantities with the stress σ along the y-axis and the strain ϵ along the x-axis is called the stress-strain diagram. The **stress-strain diagram** differs in form for various materials. The diagram shown below is that for a medium-carbon structural steel.

Metallic engineering materials are classified as either **ductile** or **brittle** materials. A ductile material is one having relatively large tensile strains up to the point of rupture like structural steel and aluminum, whereas brittle materials has a relatively small strain up to the point of rupture like cast iron and concrete. An arbitrary strain of 0.05 mm/mm is frequently taken as the dividing line between these two classes.

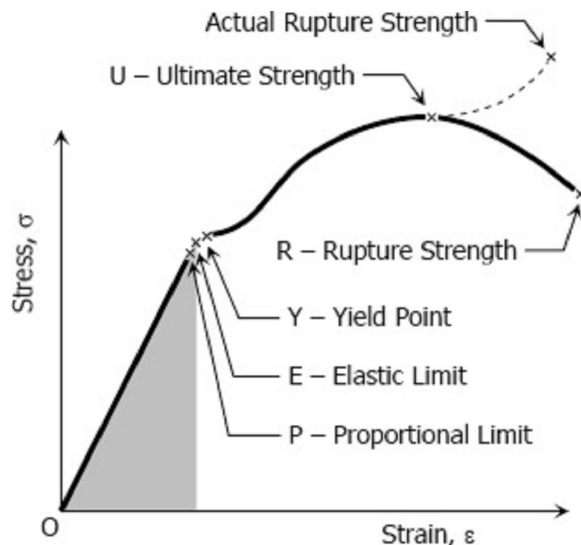

Proportional Limit (Hooke's Law)

From the origin O to the point called proportional limit, the stress-strain curve



is a straight line. This linear relation between elongation and the axial force causing was first noticed by **Sir Robert Hooke** in 1678 and is called Hooke's Law that within the proportional limit, the stress is directly proportional to strain or

$$\sigma \propto \epsilon \text{ or } \sigma = k\epsilon$$

The constant of proportionality k is called the **Modulus of Elasticity E** or **Young's Modulus** and is equal to the slope of the stress-strain diagram from O to P. Then

$$\sigma = E\epsilon$$



Robert Hooke

Elastic Limit

The elastic limit is the limit beyond which the material will no longer go back to its original shape when the load is removed, or it is the maximum stress that may be developed such that there is no permanent or residual deformation when the load is entirely removed.

Elastic Limit

The elastic limit is the limit beyond which the material will no longer go back to its original shape when the load is removed, or it is the maximum stress that may be developed such that there is no permanent or residual deformation when the load is entirely removed.

Elastic and Plastic Ranges

The region in stress-strain diagram from O to P is called the elastic range. The region from P to R is called the plastic range.

Yield Point

Yield point is the point at which the material will have an appreciable elongation or yielding without any increase in load.

Ultimate Strength

The maximum ordinate in the stress-strain diagram is the ultimate strength or tensile strength.

Rapture Strength

Rapture strength is the strength of the material at rapture. This is also known as the breaking strength.

Modulus of Resilience

Modulus of resilience is the work done on a unit volume of material as the force is gradually increased from O to P, in $\text{N} \cdot \text{m}/\text{m}^3$. This may be calculated as the area under the stress-strain curve from the origin O to up to the elastic limit E (the shaded area in the figure). The resilience of the material is its ability to absorb energy without creating a permanent distortion.

Modulus of Toughness

Modulus of toughness is the work done on a unit volume of material as the force is gradually increased

from O to R, in $\text{N} \cdot \text{m}/\text{m}^3$. This may be calculated as the area under the entire stress-strain curve (from O to R). The toughness of a material is its ability to absorb energy without causing it to break.

Working Stress, Allowable Stress, and Factor of Safety

Working stress is defined as the actual stress of a material under a given loading. The maximum safe stress that a material can carry is termed as the allowable stress. The allowable stress should be limited to values not exceeding the proportional limit. However, since proportional limit is difficult to determine accurately, the allowable stress is taken as either the yield point or ultimate strength divided by a factor of safety. The ratio of this strength (ultimate or yield strength) to allowable strength is called the factor of safety.

Axial Deformation

In the linear portion of the stress-strain diagram, the stress is proportional to strain and is given by

$$\sigma = E\varepsilon$$

since $\sigma = P/A$ and $\varepsilon = \delta/L$, then $\frac{P}{A} = E \frac{\delta}{L}$

$$\delta = \frac{PL}{AE} = \frac{\sigma L}{E}$$

To use this formula, the load must be axial, the bar must have a uniform cross-sectional area, and the stress must not exceed the proportional limit.

If however, the cross-sectional area is not uniform, the axial deformation can be determined by considering a differential length and applying integration.

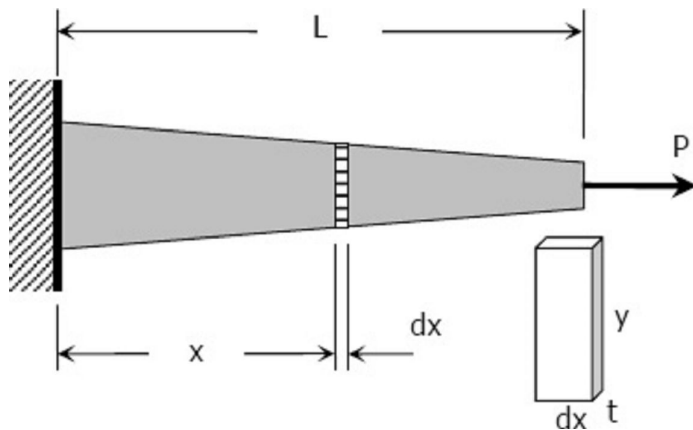

$$\delta = \frac{P}{E} \int_0^L \frac{dx}{L}$$

where $A = ty$ and y and t , if variable, must be expressed in terms of x .

For a rod of unit mass ρ suspended vertically from one end, the total elongation due to its own weight is

$$\delta = \frac{\rho g L^2}{2E} = \frac{MgL}{2AE}$$

where ρ is in kg/m^3 , L is the length of the rod in mm, M is the total mass of the rod in kg, A is the cross-sectional area of the rod in mm^2 , and $g = 9.81 \text{ m/s}^2$.

Stiffness, k

Stiffness is the ratio of the steady force acting on an elastic body to the resulting displacement. It has the unit of N/mm.

$$k = \frac{P}{\delta}$$

Solution to Problem 203 Stress-strain Diagram

Strength of Materials 4th Edition by Pytel and Singer

Given:

Material: 14-mm-diameter mild steel rod

Gage length = 50 mm

Test Result:

Load (N)	Elongation (mm)	Load (N)	Elongation (mm)
0	0	46 200	1.25
6 310	0.010	52 400	2.50
12 600	0.020	58 500	4.50
18 800	0.030	68 000	7.50
25 100	0.040	59 000	12.5
31 300	0.050	67 800	15.5
37 900	0.060	65 000	20.0
40 100	0.163	65 500	Fracture
41 600	0.433		

Required:

Stress-strain diagram, Proportional limit, modulus of elasticity, yield point, ultimate strength, and rupture strength

Solution 203

Area, $A = \frac{1}{4}\pi(14)^2 = 49\pi \text{ mm}^2$; Length, $L = 50 \text{ mm}$

Strain = Elongation/Length; Stress = Load/Area

Load (N)	Elongation (mm)	Strain (mm/mm)	Stress (MPa)
0	0	0	0
6 310	0.010	0.0002	40.99
12 600	0.020	0.0004	81.85

18 800	0.030	0.0006	122.13
25 100	0.040	0.0008	163.05
31 300	0.050	0.001	203.33
37 900	0.060	0.0012	246.20
40 100	0.163	0.0033	260.49
41 600	0.433	0.0087	270.24
46 200	1.250	0.025	300.12
52 400	2.500	0.05	340.40
58 500	4.500	0.09	380.02
68 000	7.500	0.15	441.74
59 000	12.500	0.25	383.27
67 800	15.500	0.31	440.44
65 000	20.000	0.4	422.25
61 500	Failure		399.51

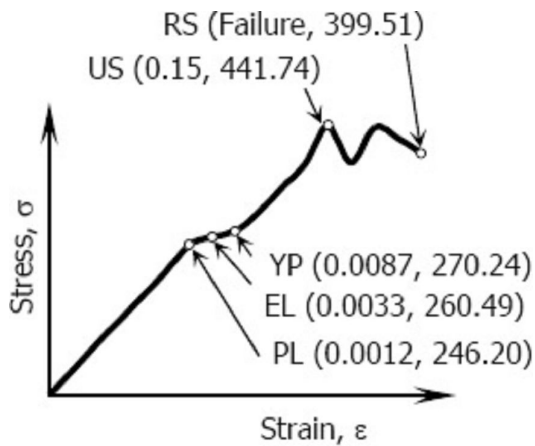

Stress-Strain Diagram
(not drawn to scale)

PL = Proportional Limit
 EL = Elastic Limit
 YP = Yield Point
 US = Ultimate Strength
 RS = Rupture Strength

From stress-strain diagram:

- Proportional Limit = **246.20 MPa**
- Modulus of Elasticity
 $E = \text{slope of stress-strain diagram within proportional limit}$

$$E = \frac{246.20}{0.0012} = 205\,166.67 \text{ MPa}$$

$$E = 205.2 \text{ GPa}$$
- Yield Point = **270.24 MPa**

- d. Ultimate Strength = **441.74 MPa**
 e. Rupture Strength = **399.51 MPa**

Solution to Problem 204 Stress-strain Diagram

Strength of Materials 4th Edition by Pytel and Singer

Given:

Material: Aluminum alloy
 Initial diameter = 0.505 inch
 Gage length = 2.0 inches
 The result of the test tabulated below:

Load (lb)	Elongation (in.)	Load (lb)	Elongation (in.)
0	0	14 000	0.020
2 310	0.00220	14 400	0.025
4 640	0.00440	14 500	0.060
6 950	0.00660	14 600	0.080
9 290	0.00880	14 800	0.100
11 600	0.0110	14 600	0.120
12 600	0.0150	13 600	Fracture

Required:

- Plot of stress-strain diagram
 (a) Proportional Limit
 (b) Modulus of Elasticity
 (c) Yield Point
 (d) Yield strength at 0.2% offset
 (e) Ultimate Strength and
 (f) Rupture Strength

Solution 204

Area, $A = \frac{1}{4}\pi(0.505)^2 = 0.0638\pi \text{ in}^2$; Length, $L = 2 \text{ in}$
 Strain = Elongation/Length; Stress = Load/Area

Load (lb)	Elongation (in.)	Strain (in/in)	Stress (psi)
0	0	0	0
2 310	0.0022	0.0011	11 532.92
4 640	0.0044	0.0022	23 165.70
6 950	0.0066	0.0033	34 698.62
9 290	0.0088	0.0044	46 381.32

11 600	0.011	0.0055	57 914.24
12 600	0.015	0.0075	62 906.85
14 000	0.02	0.01	69 896.49
14 400	0.025	0.0125	71 893.54
14 500	0.06	0.03	72 392.80
14 600	0.08	0.04	72 892.06
14 800	0.1	0.05	73 890.58
14 600	0.12	0.06	72 892.06
13 600	Fracture		67 899.45

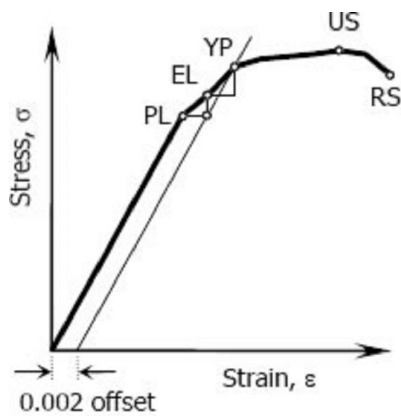

PL	(0.0055, 57914.24)
EL	(0.0075, 62906.85)
YP	(0.01, 69896.49)
US	(0.05, 73890.58)
RS	(Failure, 67899.45)

From stress-strain diagram:

- Proportional Limit = **57,914.24 psi**
- Modulus of Elasticity:

$$E = \frac{57914.24}{0.0055} = 10,529,861.82 \text{ psi}$$
 E = **10,529.86 ksi**
- Yield Point = **69,896.49 psi**
- Yield Strength at 0.2% Offset:

Strain of Elastic Limit = ϵ at PL + 0.002

Strain of Elastic Limit = 0.0055 + 0.002

Strain of Elastic Limit = 0.0075 in/in

The offset line will pass through Q(See figure):

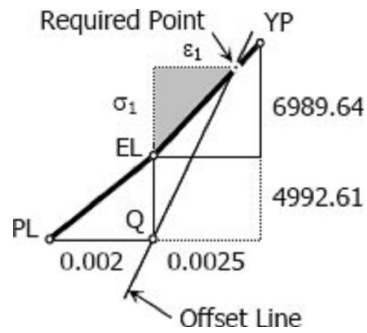

Slope of 0.2% offset = E = 10,529,861.82 psi

Test for location:

slope = rise / run

$$10,529,861.82 = \frac{6989.64 + 4992.61}{\text{run}}$$

run = 0.00113793 < 0.0025, therefore, the required point is just before YP.

Slope of EL to YP

$$\frac{\sigma_1}{\varepsilon_1} = \frac{6989.64}{0.0025}$$

$$\frac{\sigma_1}{\varepsilon_1} = 2795856$$

$$\varepsilon_1 = \frac{\sigma_1}{2795856}$$

For the required point:

$$E = \frac{4992.61 + \sigma_1}{\varepsilon_1}$$

$$10529861.82 = \frac{4992.61 + \sigma_1}{\frac{\sigma_1}{2795856}}$$

$$3.7662\sigma_1 = 4992.61 + \sigma_1$$

$$\sigma_1 = 1804.84 \text{ psi}$$

Yield Strength at 0.2% Offset

$$= EL + \sigma_1$$

$$= 62906.85 + 1804.84$$

$$= \mathbf{64,711.69 \text{ psi}}$$

e. Ultimate Strength = **73,890.58 psi**

f. Rupture Strength = **67,899.45 psi**

Solution to Problem 205 Axial Deformation

Strength of Materials 4th Edition by Pytel and Singer

Given:

Length of bar = L

Cross-sectional area = A

Unit mass = ρ

The bar is suspended vertically from one end

Required:

Show that the total elongation $\delta = \rho g L^2 / 2E$.

If total mass is M , show that $\delta = MgL/2AE$

Solution 205

$$\delta = \frac{PL}{AE}$$

From the figure:

$$\delta = d\delta$$

$$P = W_y = (\rho Ay)g$$

$$L = dy$$

$$d\delta = \frac{(\rho Ay)g dy}{AE}$$

$$\delta = \frac{\rho g}{E} \int_0^L y dy = \frac{\rho g}{E} \left[\frac{y^2}{2} \right]_0^L$$

$$\delta = \frac{\rho g}{2E} [L^2 - 0^2]$$

$$\delta = \rho g L^2 / 2E \text{ ok!}$$

Given the total mass M

$$\rho = M/V = M/AL$$

$$\delta = \frac{\rho g L^2}{2E} = \frac{\frac{M}{AL} \cdot g L^2}{2E}$$

$$\delta = \frac{MgL}{2AE} \text{ ok!}$$

Another Solution:

$$\delta = \frac{PL}{AE}$$

Where:

$$P = W = (\rho AL)g$$

$$L = L/2$$

$$\delta = \frac{[(\rho AL)g](L/2)}{AE}$$

$$\delta = \rho g L^2 / 2E \text{ ok!}$$

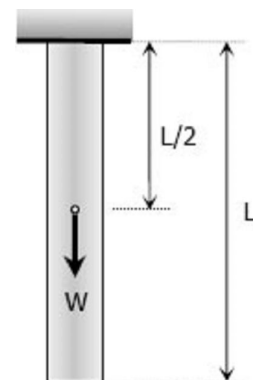
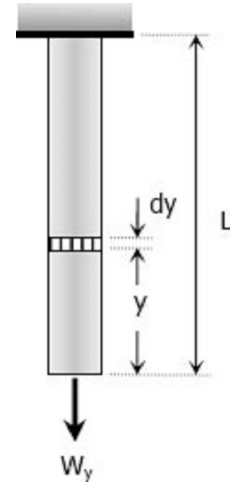

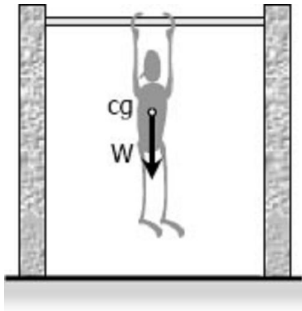

For you to feel the situation, position yourself in pull-up exercise with your hands on the bar and your body hang freely above the ground. Notice that your arms suffer all your weight and your lower body falls no stress (center of weight is approximately just below the chest). If your body is the bar, the elongation will occur at the upper half of it.

Solution to Problem 206 Axial Deformation

Strength of Materials 4th Edition by Pytel and Singer

Given:

Cross-sectional area = 300 mm^2

Length = 150 m

tensile load at the lower end = 20 kN

Unit mass of steel = 7850 kg/m^3

$E = 200 \times 10^3 \text{ MN/m}^2$

Required: Total elongation of the rod

Solution 206

Elongation due to its own weight:

$$\delta_1 = \frac{PL}{AE}$$

Where:

$$P = W = 7850(1/1000)^3(9.81)[300(150)(1000)]$$

$$P = 3465.3825 \text{ N}$$

$$L = 75(1000) = 75\,000 \text{ mm}$$

$$A = 300 \text{ mm}^2$$

$$E = 200\,000 \text{ MPa}$$

$$\delta_1 = \frac{3\,465.3825(75\,000)}{300(200\,000)}$$

$$\delta_1 = 4.33 \text{ mm}$$

Elongation due to applied load:

$$\delta_2 = \frac{PL}{AE}$$

Where:

$$P = 20 \text{ kN} = 20\,000 \text{ N}$$

$$L = 150 \text{ m} = 150\,000 \text{ mm}$$

$$A = 300 \text{ mm}^2$$

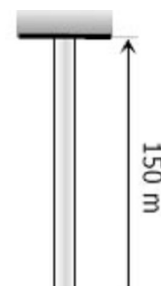
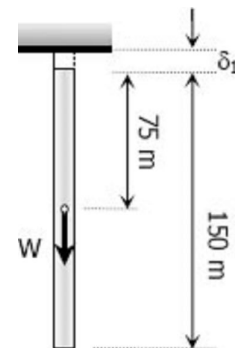

$$E = 200\,000 \text{ MPa}$$

$$\delta_2 = \frac{20\,000(150\,000)}{300(200\,000)}$$

$$\delta_2 = 50 \text{ mm}$$

Total elongation:

$$\delta = \delta_1 + \delta_2$$

$$\delta = 4.33 + 50 = 54.33 \text{ mm} \rightarrow \text{answer}$$

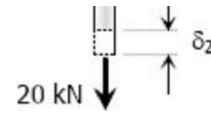

Solution to Problem 207 Axial Deformation

Strength of Materials 4th Edition by Pytel and Singer

Given:

Length of steel wire = 30 ft

Load = 500 lb

Maximum allowable stress = 20 ksi

Maximum allowable elongation = 0.20 inch

$$E = 29 \times 10^6 \text{ psi}$$

Required: Diameter of the wire

Solution 207

Based on maximum allowable stress:

$$\sigma = \frac{P}{A}$$

$$20\,000 = \frac{500}{\frac{1}{4}\pi d^2}$$

$$d = 0.1784 \text{ in}$$

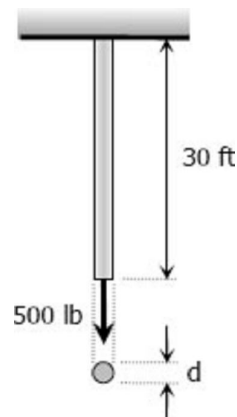

Based on maximum allowable deformation:

$$\delta = \frac{PL}{AE}$$

$$0.20 = \frac{500(30 \times 12)}{\frac{1}{4}\pi d^2(29 \times 10^6)}$$

$$d = 0.1988 \text{ in}$$

Use the bigger diameter, **d = 0.1988 inch**

Solution to Problem 208 Axial Deformation

Strength of Materials 4th Edition by Pytel and Singer
 Problem 208 page 40

Given:

- Thickness of steel tire = 100 mm
- Width of steel tire = 80 mm
- Inside diameter of steel tire = 1500.0 mm
- Diameter of steel wheel = 1500.5 mm
- Coefficient of static friction = 0.30
- E = 200 GPa

Required: Torque to twist the tire relative to the wheel

Solution 208

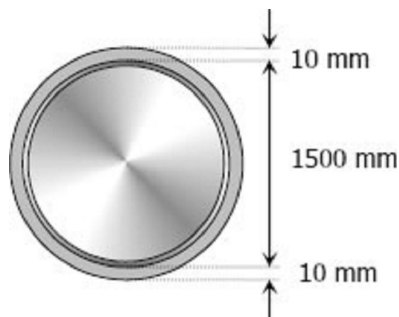

$$\delta = \frac{PL}{AE}$$

Where:

$$\delta = \pi (1500.5 - 1500) = 0.5\pi \text{ mm}$$

$$P = T$$

$$L = 1500\pi \text{ mm}$$

$$A = 10(80) = 800 \text{ mm}^2$$

$$E = 200\,000 \text{ MPa}$$

$$0.5\pi = \frac{T(1500\pi)}{800(200\,000)}$$

$$T = 53\,333.33 \text{ N}$$

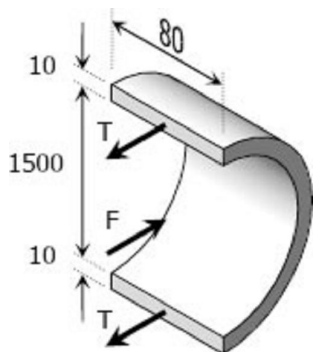

$$F = 2T$$

$$p(1500)(80) = 2(53\,333.33)$$

$$p = 0.8889 \text{ MPa} \rightarrow \text{internal pressure}$$

Total normal force, N:

$$N = p \times \text{contact area between tire and wheel}$$

$$N = 0.8889 \times \pi(1500.5)(80)$$

$$N = 335\,214.92 \text{ N}$$

Friction resistance, f:

$$f = \mu N = 0.30(335\,214.92)$$

$$f = 100\,564.48 \text{ N} = 100.56 \text{ kN}$$

$$\text{Torque} = f \times \frac{1}{2}(\text{diameter of wheel})$$

$$\text{Torque} = 100.56 \times 0.75025$$

$$\text{Torque} = 75.44 \text{ kN} \cdot \text{m}$$

Solution to Problem 209 Axial Deformation

Strength of Materials 4th Edition by Pytel and Singer

Given:

$$\text{Cross-section area} = 0.5 \text{ in}^2$$

$$E = 10 \times 10^6 \text{ psi}$$

The figure below:

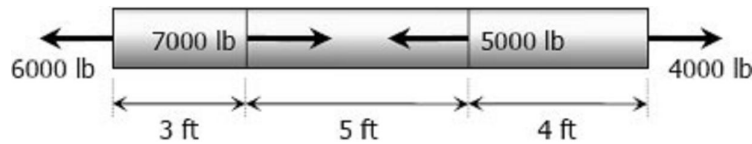
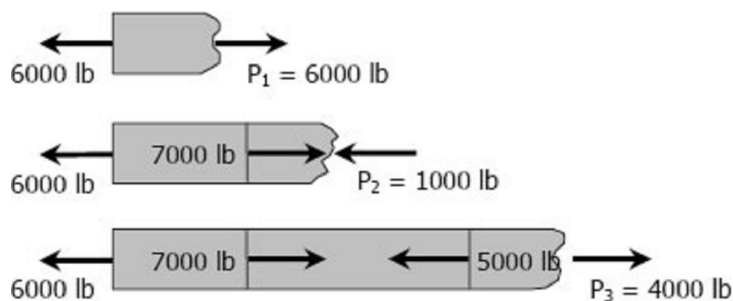

Figure P-209 and P-210

Required: Total change in length

Solution 209



$$P_1 = 6000 \text{ lb tension}$$

$$P_2 = 1000 \text{ lb compression}$$

$$P_3 = 4000 \text{ lb tension}$$

$$\delta = \frac{PL}{AE}$$

$$\delta = \delta_1 - \delta_2 + \delta_3$$

$$\delta = \frac{6000(3 \times 12)}{0.5(10 \times 10^6)} - \frac{1000(5 \times 12)}{0.5(10 \times 10^6)} + \frac{4000(4 \times 12)}{0.5(10 \times 10^6)}$$

$$\delta = 0.0696 \text{ in (lengthening)} \rightarrow \text{answer}$$

Solution to Problem 210 Axial Deformation

Solve [Prob. 209](#) if the points of application of the 6000-lb and the 4000-lb forces are interchanged.

Solution 210

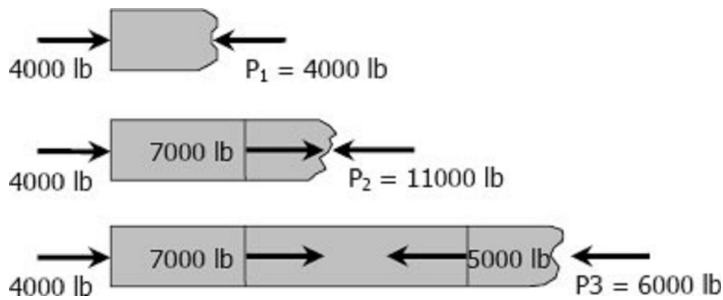

$P_1 = 4000 \text{ lb}$ compression

$P_2 = 11000 \text{ lb}$ compression

$P_3 = 6000 \text{ lb}$ compression

$$\delta = \frac{PL}{AE}$$

$$\delta = -\delta_1 - \delta_2 - \delta_3$$

$$\delta = -\frac{4000(3 \times 12)}{0.5(10 \times 10^6)} - \frac{11000(5 \times 12)}{0.5(10 \times 10^6)} - \frac{6000(4 \times 12)}{0.5(10 \times 10^6)}$$

$$\delta = -0.19248 \text{ in} = 0.19248 \text{ in (shortening)} \rightarrow \text{answer}$$

Solution to Problem 211 Axial Deformation

Strength of Materials 4th Edition by Pytel and Singer

Problem 211 page 40

Given:

Maximum overall deformation = 3.0 mm

Maximum allowable stress for steel = 140 MPa

Maximum allowable stress for bronze = 120 MPa

Maximum allowable stress for aluminum = 80 MPa

$E_{st} = 200 \text{ GPa}$

$E_{al} = 70 \text{ GPa}$

$E_{br} = 83 \text{ GPa}$

The figure below:

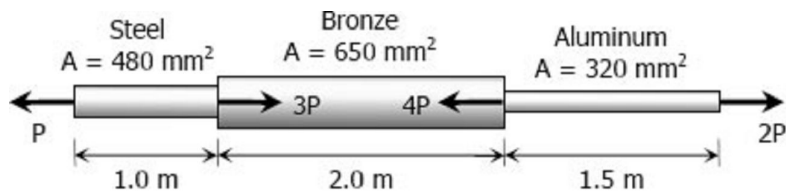
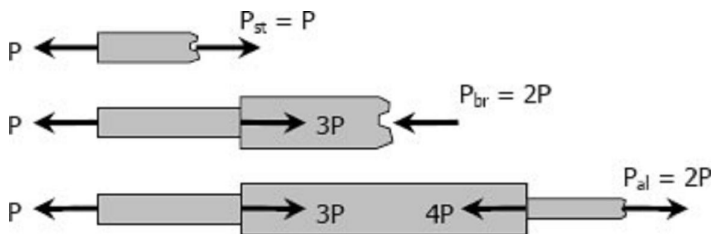

Figure P -211

Required: The largest value of P

Solution 211



Based on allowable stresses:

Steel:

$$P_{st} = \sigma_{st} A_{st}$$

$$P = 140(480) = 67\,200\text{ N}$$

$$P = 67.2\text{ kN}$$

Bronze:

$$P_{br} = \sigma_{br} A_{br}$$

$$2P = 120(650) = 78\,000\text{ N}$$

$$P = 39\,000\text{ N} = 39\text{ kN}$$

Aluminum:

$$P_{al} = \sigma_{al} A_{al}$$

$$2P = 80(320) = 25\,600\text{ N}$$

$$P = 12\,800\text{ N} = 12.8\text{ kN}$$

Based on allowable deformation:

(steel and aluminum lengthens, bronze shortens)

$$\delta = \delta_{st} - \delta_{br} + \delta_{al}$$

$$3 = \frac{P(1000)}{480(200\,000)} - \frac{2P(2000)}{650(70\,000)} + \frac{2P(1500)}{320(83\,000)}$$

$$3 = \left(\frac{1}{96\,000} - \frac{1}{11\,375} + \frac{3}{26\,560} \right) P$$

$$P = 84\,610.99\text{ N} = 84.61\text{ kN}$$

Use the smallest value of P, **P = 12.8 kN**

Solution to Problem 212 Axial Deformation

Given:

Maximum stress in steel rod = 30 ksi

Maximum vertical movement at C = 0.10 inch

The figure below:

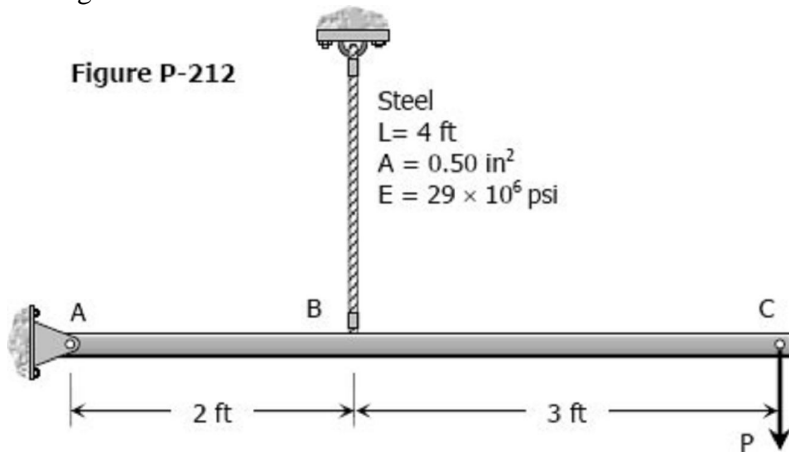

Required: The largest load P that can be applied at C

Solution 212

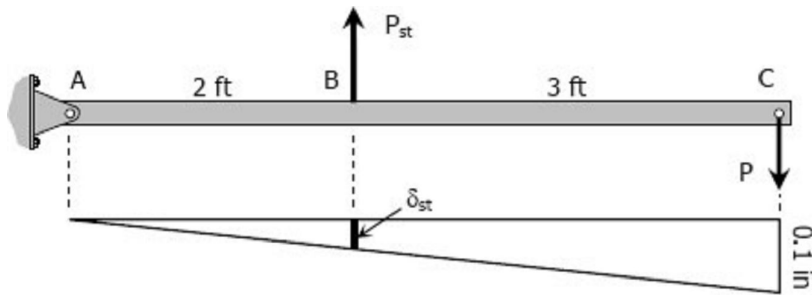

Based on maximum stress of steel rod:

$$\sum M_A = 0$$

$$5P = 2P_{st}$$

$$P = 0.4P_{st}$$

$$P = 0.4\sigma_{at}A_{st}$$

$$P = 0.4 [30(0.50)]$$

$$P = 6 \text{ kips}$$

Based on movement at C:

$$\frac{\delta_{st}}{2} = \frac{0.1}{5}$$

$$\delta_{st} = 0.04 \text{ in}$$

$$\frac{P_{st}L}{AE} = 0.04$$

$$\frac{P_{st}(4 \times 12)}{0.50(29 \times 10^6)} = 0.04$$

$$P_{st} = 12083.33 \text{ lb}$$

$$\sum M_A = 0$$

$$5P = 2P_{st}$$

$$P = 0.4P_{st}$$

$$P = 0.4(12\,083.33)$$

$$P = 4833.33 \text{ lb} = 4.83 \text{ kips}$$

Use the smaller value, $P = 4.83 \text{ kips}$

Solution to Problem 213 Axial Deformation

Strength of Materials 4th Edition by Pytel and Singer

Given:

Rigid bar is horizontal before $P = 50 \text{ kN}$ is applied

The figure below:

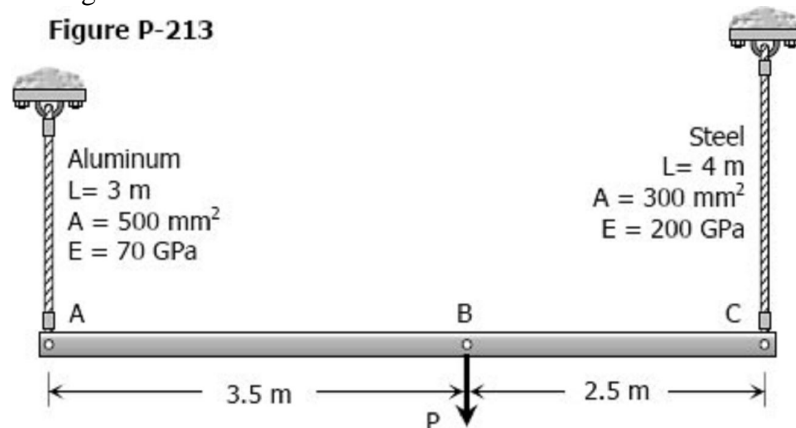

Required: Vertical movement of P

Solution 213

Free body diagram:

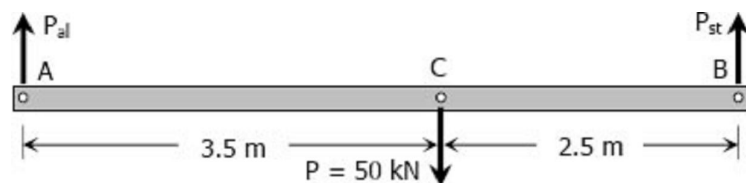

For aluminum:

$$\sum M_B = 0$$

$$6P_{al} = 2.5(50)$$

$$P_{al} = 20.83 \text{ kN}$$

$$\delta = \frac{PL}{AE}$$

$$\delta_{al} = \frac{20.83(3)1000^2}{500(70\,000)}$$

$$\delta_{al} = 1.78 \text{ mm}$$

For steel:

$$\sum M_A = 0$$

$$6P_{st} = 3.5(50)$$

$$P_{st} = 29.17 \text{ kN}$$

$$\delta = \frac{PL}{AE}$$

$$\delta_{st} = \frac{29.17(4)1000^2}{300(200\,000)}$$

$$\delta_{st} = 1.94 \text{ mm}$$

Movement diagram:

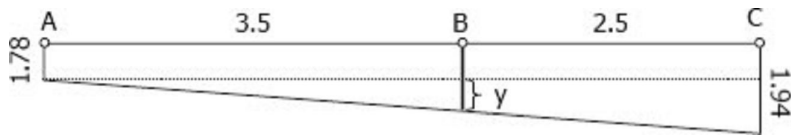

$$\frac{y}{3.5} = \frac{1.94 - 1.78}{6}$$

$$y = 0.09 \text{ mm}$$

δ_B = vertical movement of P

$$\delta_B = 1.78 + y = 1.78 + 0.09$$

$$\delta_B = 1.87 \text{ mm} \rightarrow \text{answer}$$

Solution to Problem 214 Axial Deformation

Strength of Materials 4th Edition by Pytel and Singer

Given:

Maximum vertical movement of $P = 5 \text{ mm}$

The figure below:

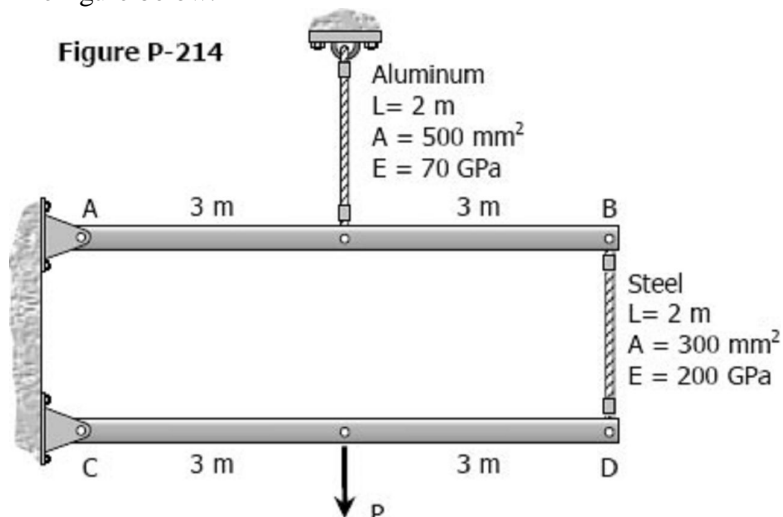

Required: The maximum force P that can be applied neglecting the weight of all members.

Solution 41

Member AB:

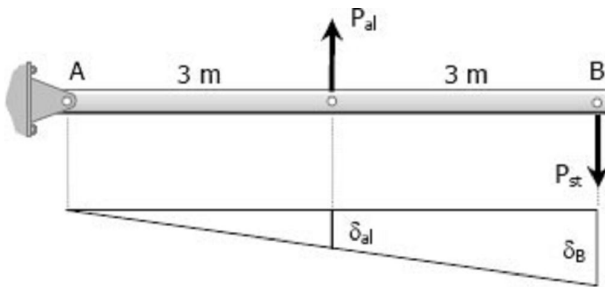

FBD and movement diagram of bar AB

$$\Sigma M_A = 0$$

$$3P_{al} = 6P_{st}$$

$$P_{al} = 2P_{st}$$

By ratio and proportion:

$$\frac{\delta_B}{6} = \frac{\delta_{al}}{3}$$

$$\delta_B = 2\delta_{al} = 2 \left[\frac{PL}{AE} \right]_{al}$$

$$\delta_B = 2 \left[\frac{P_{al}(2000)}{500(70\,000)} \right]$$

$$\delta_B = \frac{1}{8750} P_{al} = \frac{1}{8750} (2P_{st})$$

$$\delta_B = \frac{1}{4375} P_{st} \rightarrow \text{movement of B}$$

Member CD:

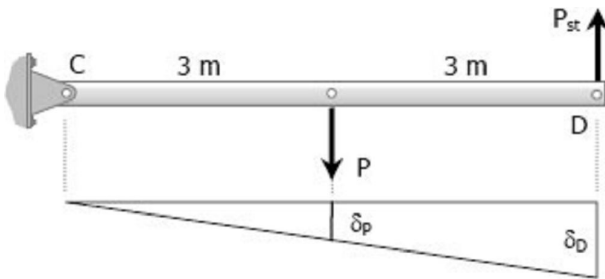

FBD and movement diagram of bar CD

Movement of D:

$$\delta_D = \delta_{st} + \delta_B = \left[\frac{PL}{AE} \right]_{st} + \frac{1}{4375} P_{st}$$

$$\delta_D = \frac{P_{st}(2000)}{300(200\,000)} + \frac{1}{4375} P_{st}$$

$$\delta_D = \frac{11}{42\,000} P_{st}$$

$$\Sigma M_C = 0$$

$$6P_{st} = 3P$$

$$P_{st} = \frac{1}{2}P$$

By ratio and proportion:

$$\frac{\delta_P}{3} = \frac{\delta_D}{6}$$

$$\delta_P = \frac{1}{2}\delta_D = \frac{1}{2}\left(\frac{11}{42\,000}P_{st}\right)$$

$$\delta_P = \frac{11}{84\,000}P_{st}$$

$$5 = \frac{11}{84\,000}\left(\frac{1}{2}P\right)$$

$$P = 76\,363.64 \text{ N} = 76.4 \text{ kN} \rightarrow \text{answer}$$

Solution to Problem 215 Axial Deformation

Strength of Materials 4th Edition by Pytel and Singer

Given:

The figure below:

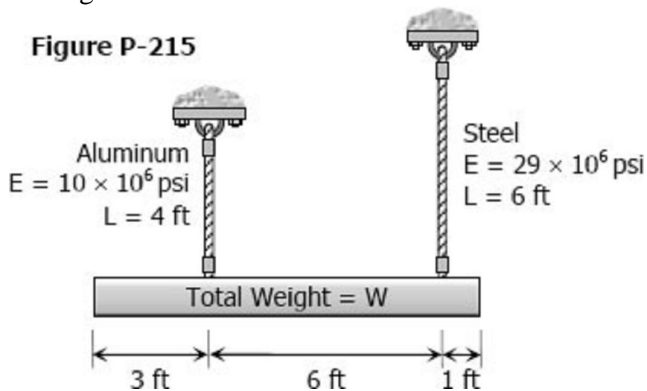

Required: Ratio of the areas of the rods

Solution 215

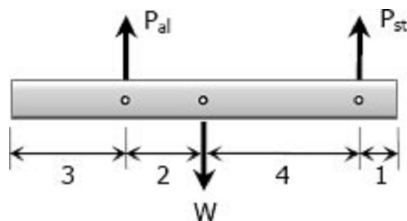

$$\Sigma M_{al} = 0$$

$$6P_{st} = 2W$$

$$P_{st} = \frac{1}{3}W$$

$$\Sigma M_{st} = 0$$

$$6P_{al} = 4W$$

$$P_{al} = \frac{2}{3}W$$

$$\delta_{st} = \delta_{al}$$

$$\left[\frac{PL}{AE} \right]_{st} = \left[\frac{PL}{AE} \right]_{al}$$

$$\frac{\frac{1}{3}W(6 \times 12)}{A_{st}(29 \times 10^6)} = \frac{\frac{2}{3}W(4 \times 12)}{A_{al}(10 \times 10^6)}$$

$$\frac{A_{al}}{A_{st}} = \frac{\frac{2}{3}W(4 \times 12)(29 \times 10^6)}{\frac{1}{3}W(6 \times 12)(10 \times 10^6)}$$

$$\frac{A_{al}}{A_{st}} = 3.867 \rightarrow \text{answer}$$

Solution to Problem 216 Axial Deformation

Strength of Materials 4th Edition by Pytel and Singer

Given:

Vertical load $P = 6000 \text{ lb}$

Cross-sectional area of each rod = 0.60 in^2

$E = 10 \times 10^6 \text{ psi}$

$\alpha = 30^\circ$

$\theta = 30^\circ$

The figure below:

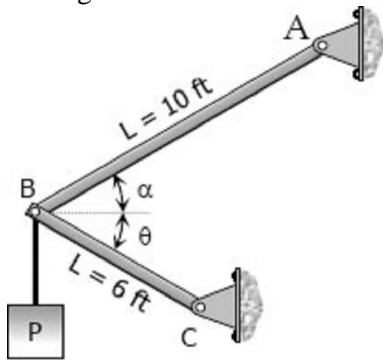
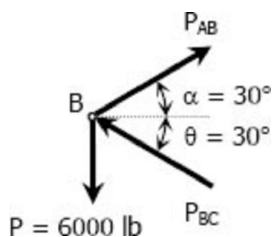

Figure P-216 and P-217

Required: Elongation of each rod and the horizontal and vertical displacements of point B

Solution 216



$$\Sigma F_H = 0$$

$$P_{AB} \cos 30^\circ = P_{BC} \cos 30^\circ$$

$$P_{AB} = P_{BC}$$

$$\Sigma F_V = 0$$

$$P_{AB} \sin 30^\circ + P_{BC} \sin 30^\circ = 6000$$

$$P_{AB}(0.5) + P_{AB}(0.5) = 6000$$

$$P_{AB} = 6000 \text{ lb tension}$$

$$P_{BC} = 6000 \text{ lb compression}$$

$$\delta = \frac{PL}{AE}$$

$$\delta_{AB} = \frac{6000(10 \times 12)}{0.6(10 \times 10^6)} = 0.12 \text{ inch lengthening} \rightarrow \text{answer}$$

$$\delta_{BC} = \frac{6000(6 \times 12)}{0.6(10 \times 10^6)} = 0.072 \text{ inch shortening} \rightarrow \text{answer}$$

$$DB = \delta_{AB} = 0.12 \text{ inch}$$

$$BE = \delta_{BE} = 0.072 \text{ inch}$$

$$\delta_B = BB' = \text{displacement of } B$$

B' = final position of B after elongation

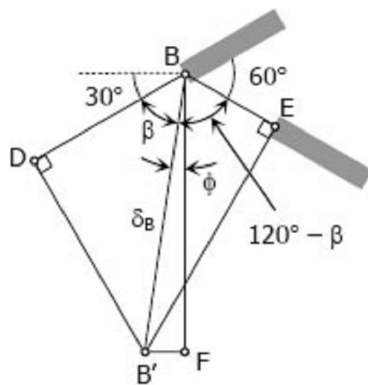

Movement of B

Triangle BDB':

$$\cos \beta = \frac{0.12}{\delta_B}$$

$$\delta_B = \frac{0.12}{\cos \beta}$$

Triangle BEB':

$$\cos(120^\circ - \beta) = \frac{0.072}{\delta_B}$$

$$\delta_B = \frac{0.072}{\cos(120^\circ - \beta)}$$

$$\delta_B = \delta_B$$

$$\frac{0.12}{\cos \beta} = \frac{0.072}{\cos(120^\circ - \beta)}$$

$$\frac{\cos 120^\circ \cos \beta + \sin 120^\circ \sin \beta}{\cos \beta} = 0.6$$

$$-0.5 + \sin 120^\circ \tan \beta = 0.6$$

$$\tan \beta = \frac{1.1}{\sin 120^\circ}$$

$$\beta = 51.79^\circ$$

$$\phi = 90^\circ - (30^\circ + \beta) = 90^\circ - (30^\circ + 51.79^\circ)$$

$$\phi = 8.21^\circ$$

$$\delta_B = \frac{0.12}{\cos 51.79^\circ}$$

$$\delta_B = 0.194 \text{ inch}$$

Triangle BFB':

$$\delta_h = B'F = \delta_B \sin \phi = 0.194 \sin 8.21^\circ$$

$$\delta_h = 0.0277 \text{ inch}$$

$$\delta_h = 0.0023 \text{ ft} \rightarrow \text{horizontal displacement of B}$$

$$\delta_v = BF = \delta_B \cos \phi = 0.194 \cos 8.21^\circ$$

$$\delta_v = 0.192 \text{ inch}$$

$$\delta_v = 0.016 \text{ ft} \rightarrow \text{vertical displacement of B}$$

Solution to Problem 217 Axial Deformation

Solve [Prob. 216](#) if rod AB is of steel, with $E = 29 \times 10^6$ psi. Assume $\alpha = 45^\circ$ and $\theta = 30^\circ$; all other data remain unchanged.

Solution 217

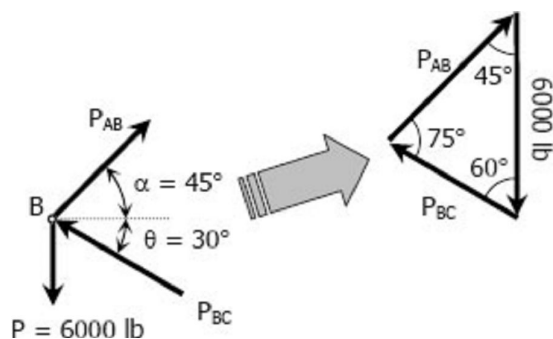

By Sine Law

$$\frac{P_{AB}}{\sin 60^\circ} = \frac{6000}{\sin 75^\circ}$$

$$P_{AB} = 5379.45 \text{ lb (Tension)}$$

$$\frac{P_{BC}}{\sin 45^\circ} = \frac{6000}{\sin 75^\circ}$$

$$P_{BC} = 4392.30 \text{ lb (Compression)}$$

$$\delta = \frac{PL}{AE}$$

$$\delta_{AB} = \frac{5379.45(10 \times 12)}{0.6(29 \times 10^6)} = 0.0371 \text{ inch (lengthening)}$$

$$\delta_{BC} = \frac{4392.30(6 \times 12)}{0.6(10 \times 10^6)} = 0.0527 \text{ inch (shortening)}$$

$$DB = \delta_{AB} = 0.0371 \text{ inch}$$

$$BE = \delta_{BE} = 0.0527 \text{ inch}$$

$$\delta_B = BB' = \text{displacement of } B$$

B' = final position of B after deformation

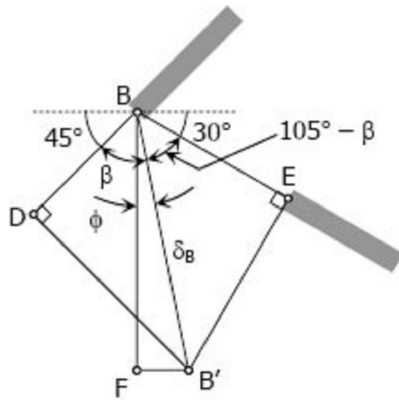

Movement of B

Triangle BDB':

$$\cos \beta = \frac{0.0371}{\delta_B}$$

$$\delta_B = \frac{0.0371}{\cos \beta}$$

Triangle BEB':

$$\cos(105^\circ - \beta) = \frac{0.0527}{\delta_B}$$

$$\delta_B = \frac{0.0527}{\cos(105^\circ - \beta)}$$

$$\delta_B = \delta_B$$

$$\frac{0.0371}{\cos \beta} = \frac{0.0527}{\cos(105^\circ - \beta)}$$

$$\frac{\cos 105^\circ \cos \beta + \sin 105^\circ \sin \beta}{\cos \beta} = 1.4205$$

$$-0.2588 + 0.9659 \tan \beta = 1.4205$$

$$\tan \beta = \frac{1.4205 + 0.2588}{0.9659}$$

$$\tan \beta = 1.7386$$

$$\beta = 60.1^\circ$$

$$\delta_B = \frac{0.0371}{\cos 60.1^\circ}$$

$$\delta_B = 0.0744 \text{ inch}$$

$$\phi = (45^\circ + \beta) - 90^\circ$$

$$\phi = (45^\circ + 60.1^\circ) - 90^\circ$$

$$\phi = 15.1^\circ$$

Triangle BFB':

$$\delta_h = FB' = \delta_B \sin \phi = 0.0744 \sin 15.1^\circ$$

$$\delta_h = 0.0194 \text{ inch}$$

$$\delta_h = 0.00162 \text{ ft} \rightarrow \text{horizontal displacement of } B$$

$$\delta_v = BF = \delta_B \cos \phi = 0.0744 \cos 15.1^\circ$$

$$\delta_v = 0.07183 \text{ inch}$$

$$\delta_v = 0.00598 \text{ ft} \rightarrow \text{vertical displacement of } B$$

Solution to Problem 218 Axial Deformation

A uniform slender rod of length L and cross sectional area A is rotating in a horizontal plane about a vertical axis through one end. If the unit mass of the rod is ρ , and it is rotating at a constant angular velocity of ω rad/sec, show that the total elongation of the rod is $\rho\omega^2 L^3/3E$.

Solution 218

$$\delta = \frac{PL}{AE}$$

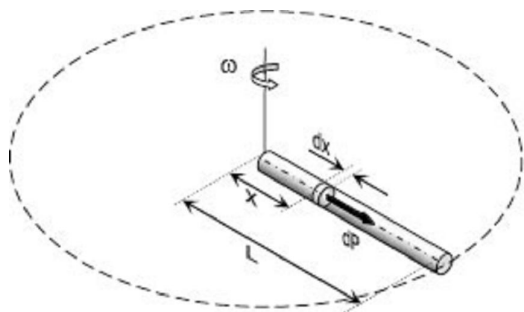

from the figure:

$$d\delta = \frac{dP x}{AE}$$

Where:

$dP = \text{centrifugal force of differential mass}$

$$dP = dM \omega^2 x = (\rho A dx) \omega^2 x$$

$$dP = \rho A \omega^2 x dx$$

$$d\delta = \frac{(\rho A \omega^2 x dx)x}{AE}$$

$$\delta = \frac{\rho \omega^2}{E} \int_0^L x^2 dx = \frac{\rho \omega^2}{E} \left[\frac{x^3}{3} \right]_0^L$$

$$\delta = \frac{\rho \omega^2}{E} [L^3 - 0^3]$$

$$\delta = \rho \omega^2 L^3 / 3E \text{ ok!}$$

Solution to Problem 219 Axial Deformation

A round bar of length L , which tapers uniformly from a diameter D at one end to a smaller diameter d at the other, is suspended vertically from the large end. If w is the weight per unit volume, find the elongation of the rod caused by its own weight. Use this result to determine the elongation of a cone suspended from its base.

Solution 219

$$\delta = \frac{PL}{AE}$$

For the differential strip shown:

$$\delta = d\delta$$

$P = \text{weight carried by the strip} = \text{weight of segment } y$

$L = dy$

$A = \text{area of the strip}$

For weight of segment y (Frustum of a cone):

$$P = wV_y$$

From section along the axis:

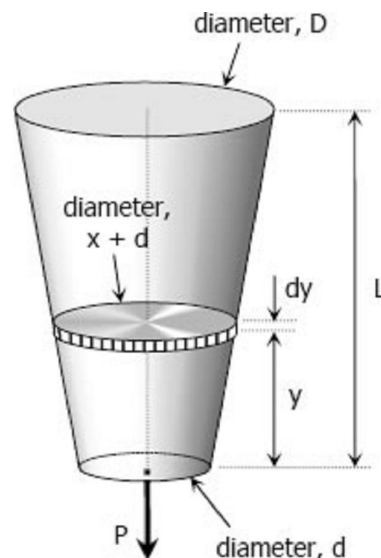

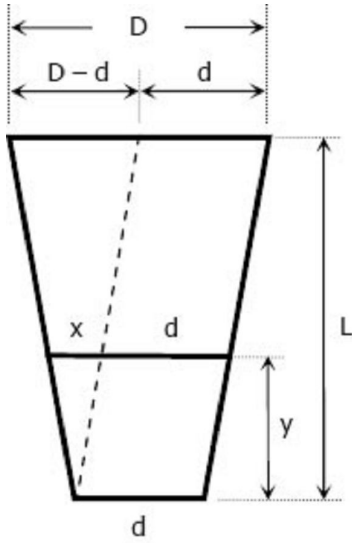

Section along the axis of the bar

$$\frac{x}{y} = \frac{D-d}{L}$$

$$x = \frac{D-d}{L} y$$

Volume for frustum of cone

$$V = \frac{1}{3} \pi h (R^2 + r^2 + Rr)$$

$$V_y = \frac{1}{3} \pi h \left[\frac{1}{4} (x+d)^2 + \frac{1}{4} d^2 + \frac{1}{2} (x+d) \left(\frac{1}{2} d \right) \right]$$

$$V_y = \frac{1}{12} \pi y \left[(x+d)^2 + d^2 + (x+d)d \right]$$

$$P = \frac{1}{12} \pi w \left[(x+d)^2 + d^2 + (x+d)d \right] y$$

$$P = \frac{1}{12} \pi w \left[x^2 + 2xd + d^2 + d^2 + xd + d^2 \right] y$$

$$P = \frac{1}{12} \pi w \left[x^2 + 3xd + 3d^2 \right] y$$

$$P = \frac{\pi w}{12} \left[\frac{(D-d)^2}{L^2} y^2 + \frac{3d(D-d)}{L} y + 3d^3 \right] y$$

Area of the strip:

$$A = \frac{1}{4} \pi (x+d)^2 = \frac{\pi}{4} \left(\frac{D-d}{L} y + d \right)^2$$

Thus,

$$\delta = \frac{PL}{AE}$$

$$d\delta = \frac{\frac{\pi w}{12} \left[\frac{(D-d)^2}{L^2} y^2 + \frac{3d(D-d)}{L} y + 3d^3 \right] y dy}{\frac{\pi}{4} \left(\frac{D-d}{L} y + d \right)^2 E}$$

$$d\delta = \frac{4w}{12E} \left[\frac{\frac{(D-d)^2}{L^2} y^2 + \frac{3d(D-d)}{L} y + 3d^2}{\frac{(D-d)^2}{L^2} y^2 + \frac{2d(D-d)}{L} y + d^2} \right] y dy$$

$$d\delta = \frac{w}{3E} \left[\frac{\frac{(D-d)^2 y^2 + 3Ld(D-d)y + 3L^2 d^2}{L^2}}{\frac{(D-d)^2 y^2 + 2Ld(D-d)y + L^2 d^2}{L^2}} \right] y dy$$

$$d\delta = \frac{w}{3E} \left[\frac{(D-d)^2 y^2 + 3Ld(D-d)y + 3L^2 d^2}{(D-d)^2 y^2 + 2Ld(D-d)y + L^2 d^2} \right] y dy$$

Let: $a = D - d$ and $b = Ld$

$$d\delta = \frac{w}{3E} \left[\frac{a^2 y^2 + 3ab y + 3b^2}{a^2 y^2 + 2ab y + b^2} \right] y dy$$

$$d\delta = \frac{w}{3E} \left[\frac{a^2 y^2 + 3ab y + 3b^2}{(ay)^2 + 2(ay)b + b^2} \times \frac{a}{a} \right] y dy$$

$$d\delta = \frac{w}{3aE} \left[\frac{a^3 y^3 + 3(a^2 y^2)b + 3(ay)b^2}{(ay + b)^2} \right] dy$$

$$d\delta = \frac{w}{3aE} \left\{ \frac{[(ay)^3 + 3(ay)^2 b + 3(ay)b^2 + b^3] - b^3}{(ay + b)^2} \right\} dy$$

The quantity $(ay)^3 + 3(ay)^2 b + 3(ay)b^2 + b^3$ is the expansion of $(ay + b)^3$

$$d\delta = \frac{w}{3aE} \left[\frac{(ay + b)^3 - b^3}{(ay + b)^2} \right] dy$$

$$d\delta = \frac{w}{3aE} \left[\frac{(ay + b)^3}{(ay + b)^2} - \frac{b^3}{(ay + b)^2} \right] dy$$

$$d\delta = \frac{w}{3aE} [(ay + b) - b^3(ay + b)^{-2}] dy$$

$$\delta = \frac{w}{3aE} \int_0^L [(ay + b) - b^3(ay + b)^{-2}] dy$$

$$\delta = \frac{w}{3aE} \left[\frac{(ay + b)^2}{2a} - \frac{b^3(ay + b)^{-1}}{-a} \right]_0^L$$

$$\delta = \frac{w}{3a^2 E} \left[\frac{(ay + b)^2}{2} + \frac{b^3}{ay + b} \right]_0^L$$

$$\delta = \frac{w}{3a^2 E} \left\{ \left[\frac{1}{2}(aL + b)^2 + \frac{b^3}{aL + b} \right] - \left[\frac{1}{2}b^2 + \frac{b^3}{b} \right] \right\}$$

$$\delta = \frac{w}{3a^2 E} \left\{ \frac{1}{2}(aL + b)^2 + \frac{b^3}{aL + b} - \frac{3}{2}b^2 \right\}$$

$$\delta = \frac{w}{3a^2E} \left[\frac{(aL+b)^3 + 2b^3 - 3b^2(aL+b)}{2(aL+b)} \right]$$

$$\delta = \frac{w}{6a^2E} \left[\frac{(aL)^3 + 3(aL)^2b + 3(aL)b^2 + b^3 + 2b^3 - 3ab^2L - 3b^3}{aL+b} \right]$$

$$\delta = \frac{w}{6a^2E} \left[\frac{a^3L^3 + 3a^2bL^2}{aL+b} \right]$$

Note that we let $a = D-d$ and $b = Ld$

$$\delta = \frac{w}{6(D-d)^2E} \left[\frac{(D-d)^3L^3 + 3(D-d)^2(Ld)L^2}{(D-d)L + Ld} \right]$$

$$\delta = \frac{w}{6(D-d)^2E} \left\{ \frac{(D-d)L^3 [(D-d)^2 + 3d(D-d)]}{LD - Ld + Ld} \right\}$$

$$\delta = \frac{wL^3}{6(D-d)E} \left[\frac{(D-d)^2 + 3d(D-d)}{LD} \right]$$

$$\delta = \frac{wL^3}{6(D-d)E} \left[\frac{D^2 - 2Dd + d^2 + 3Dd - 3d^2}{LD} \right]$$

$$\delta = \frac{wL^3}{6(D-d)E} \left[\frac{D^2 + Dd - 2d^2}{LD} \right]$$

$$\delta = \frac{wL^3}{6(D-d)E} \left[\frac{D(D+d) - 2d^2}{LD} \right]$$

$$\delta = \frac{wL^3}{6(D-d)E} \left[\frac{D(D+d)}{LD} \right] - \frac{wL^3}{6(D-d)E} \left[\frac{2d^2}{LD} \right]$$

$$\delta = \frac{wL^2(D+d)}{6E(D-d)} - \frac{wL^2d^2}{3ED(D-d)} \rightarrow \text{answer}$$

For a cone: $D = D$ and $d = 0$

$$\delta = \frac{wL^2(D+0)}{6E(D-0)} - \frac{wL^2(0^2)}{3ED(D-0)}$$

$$\delta = \frac{wL^2}{6E} \rightarrow \text{answer}$$

Shearing Deformation

Shearing Deformation

Shearing forces cause shearing deformation. An element subject to shear does not change in length but undergoes a change in shape.

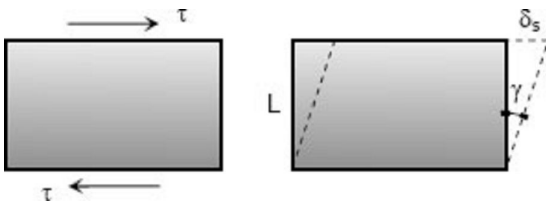

The change in angle at the corner of an original rectangular element is called the **shear strain** and is expressed as

$$\gamma = \frac{\delta_s}{L}$$

The ratio of the shear stress τ and the shear strain γ is called the *modulus of elasticity in shear* or **modulus of rigidity** and is denoted as G , in MPa.

$$G = \frac{\tau}{\gamma}$$

The relationship between the shearing deformation and the applied shearing force is

$$\delta_s = \frac{VL}{A_s G} = \frac{\tau L}{G}$$

where V is the shearing force acting over an area A_s .

Poisson's Ratio

When a bar is subjected to a tensile loading there is an increase in length of the bar in the direction of the applied load, but there is also a decrease in a lateral dimension perpendicular to the load. The ratio of the sidewise deformation (or strain) to the longitudinal deformation (or strain) is called the Poisson's ratio and is denoted by ν . For most steel, it lies in the range of 0.25 to 0.3, and 0.20 for concrete.

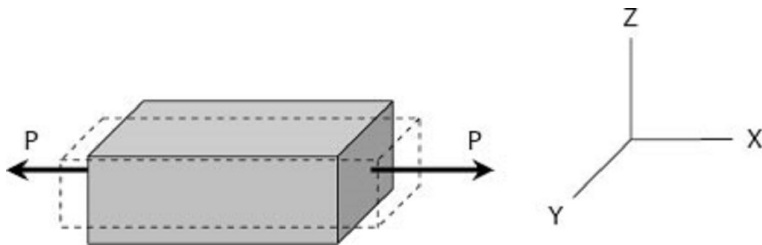

$$\nu = -\frac{\epsilon_y}{\epsilon_x} = -\frac{\epsilon_z}{\epsilon_x}$$

where ϵ_x is strain in the x -direction and ϵ_y and ϵ_z are the strains in the perpendicular direction. The negative sign indicates a decrease in the transverse dimension when ϵ_x is positive.

Biaxial Deformation

If an element is subjected simultaneously by tensile stresses, σ_x and σ_y , in the x and y directions, the strain in the x direction is σ_x/E and the strain in the y direction is σ_y/E . Simultaneously, the stress in the y direction will produce a lateral contraction on the x direction of the amount $-\nu \epsilon_y$ or $-\nu \sigma_y/E$.

The resulting strain in the x direction will be

$$\varepsilon_x = \frac{\sigma_x}{E} - \nu \frac{\sigma_y}{E} \quad \text{or} \quad \sigma_x = \frac{(\varepsilon_x + \nu\varepsilon_y)E}{1 - \nu^2}$$

and

$$\varepsilon_y = \frac{\sigma_y}{E} - \nu \frac{\sigma_x}{E} \quad \text{or} \quad \sigma_y = \frac{(\varepsilon_y + \nu\varepsilon_x)E}{1 - \nu^2}$$

Triaxial Deformation

If an element is subjected simultaneously by three mutually perpendicular normal stresses σ_x , σ_y , and σ_z , which are accompanied by strains ε_x , ε_y , and ε_z , respectively,

$$\varepsilon_x = \frac{1}{E} [\sigma_x - \nu(\sigma_y + \sigma_z)]$$

$$\varepsilon_y = \frac{1}{E} [\sigma_y - \nu(\sigma_x + \sigma_z)]$$

$$\varepsilon_z = \frac{1}{E} [\sigma_z - \nu(\sigma_x + \sigma_y)]$$

Tensile stresses and elongation are taken as positive. Compressive stresses and contraction are taken as negative.

Relationship Between E , G , and ν

The relationship between modulus of elasticity E , shear modulus G and Poisson's ratio ν is:

$$G = \frac{E}{2(1 + \nu)}$$

Bulk Modulus of Elasticity or Modulus of Volume Expansion, K

The bulk modulus of elasticity K is a measure of a resistance of a material to change in volume without change in shape or form. It is given as

$$K = \frac{E}{3(1 - 2\nu)} = \frac{\sigma}{\Delta V/V}$$

where V is the volume and ΔV is change in volume. The ratio $\Delta V/V$ is called volumetric strain and can be expressed as

$$\frac{\Delta V}{V} = \frac{\sigma}{K} = \frac{3(1 - 2\nu)}{E}$$

Solution to Problem 222 Poisson's Ratio

A solid cylinder of diameter d carries an axial load P . Show that its change in diameter is $4P\nu / \pi Ed$.

Solution 222

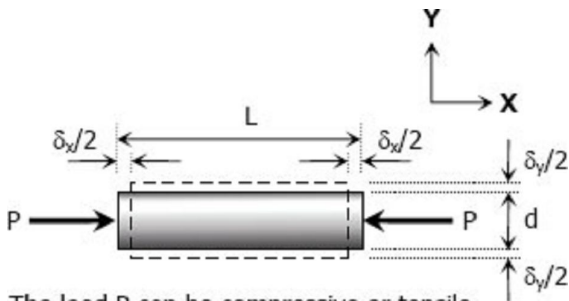

The load P can be compressive or tensile

$$\nu = -\frac{\epsilon_y}{\epsilon_x}$$

$$\epsilon_y = -\nu \epsilon_x$$

$$\epsilon_y = -\nu \frac{\sigma_x}{E}$$

$$\frac{\delta_y}{d} = -\nu \frac{-P}{AE}$$

$$\delta_y = \frac{Pd}{\frac{1}{4}\pi d^2 E}$$

$$\delta_y = \frac{4P\nu}{\pi Ed} \rightarrow \text{ok}$$

Solution to Problem 223 Triaxial Deformation

Strength of Materials 4th Edition by Pytel and Singer

Given:

Dimensions of the block:

x direction = 3 inches

y direction = 2 inches

z direction = 4 inches

Triaxial loads in the block

x direction = 48 kips tension

y direction = 60 kips compression

z direction = 54 kips tension

Poisson's ratio, $\nu = 0.30$

Modulus of elasticity, $E = 29 \times 10^6$ psi

Required:

Single uniformly distributed load in the x direction that would produce the same deformation in the y direction as the original loading.

Solution 223

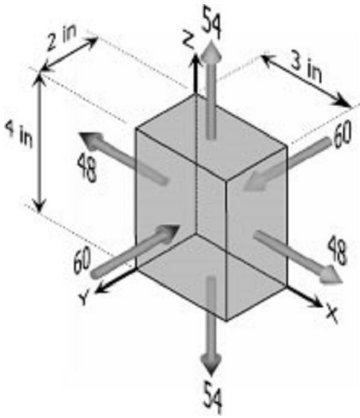

For triaxial deformation (tensile triaxial stresses):

(compressive stresses are negative stresses)

$$\varepsilon_y = \frac{1}{E} [\sigma_y - \nu(\sigma_x + \sigma_z)]$$

$$\sigma_x = \frac{P_x}{A_{yz}} = \frac{48}{4(2)} = 6.0 \text{ ksi (tension)}$$

$$\sigma_y = \frac{P_y}{A_{xz}} = \frac{60}{4(3)} = 5.0 \text{ ksi (compression)}$$

$$\sigma_z = \frac{P_z}{A_{xy}} = \frac{54}{2(3)} = 9.0 \text{ ksi (tension)}$$

$$\varepsilon_y = \frac{1}{29 \times 10^6} [-5000 - 0.30(6000 + 9000)]$$

$$\varepsilon_y = -3.276 \times 10^{-4}$$

ε_y is negative, thus tensile force is required in the x-direction to produce the same deformation in the y-direction as the original forces.

For equivalent single force in the x-direction:

(uniaxial stress)

$$\nu = -\frac{\varepsilon_y}{\varepsilon_x}$$

$$-\nu\varepsilon_x = \varepsilon_y$$

$$-\nu \frac{\sigma_x}{E} = \varepsilon_y$$

$$-0.30 \left(\frac{\sigma_x}{29 \times 10^6} \right) = -3.276 \times 10^{-4}$$

$$\sigma_x = 31\,666.67 \text{ psi}$$

$$\sigma_x = \frac{P_x}{4(2)} = 31\,666.67$$

$$P_x = 253\,333.33 \text{ lb (tension)}$$

$$P_x = 253.33 \text{ kips (tension)} \rightarrow \text{answer}$$

Solution to Problem 224 Triaxial Deformation

Problem 224

For the block loaded triaxially as described in [Prob. 223](#), find the uniformly distributed load that must be added in the x direction to produce no deformation in the z direction.

Solution 224

$$\varepsilon_z = \frac{1}{E} [\sigma_z - \nu(\sigma_x + \sigma_y)]$$

Where

$$\sigma_x = 6.0 \text{ ksi (tension)}$$

$$\sigma_y = 5.0 \text{ ksi (compression)}$$

$$\sigma_z = 9.0 \text{ ksi (tension)}$$

$$\varepsilon_z = \frac{1}{29 \times 10^6} [9000 - 0.3(6000 - 5000)]$$

$$\varepsilon_z = 2.07 \times 10^{-5}$$

ε_z is positive, thus positive stress is needed in the x-direction to eliminate deformation in z-direction.

The application of loads is still simultaneous:

(No deformation means zero strain)

$$\varepsilon_z = \frac{1}{E} [\sigma_z - \nu(\sigma_x + \sigma_y)] = 0$$

$$\sigma_z = \nu(\sigma_x + \sigma_y)$$

$$\sigma_y = 5.0 \text{ ksi (compression)}$$

$$\sigma_z = 9.0 \text{ ksi (tension)}$$

$$9000 = 0.30(\sigma_x - 5000)$$

$$\sigma_x = 35\,000 \text{ psi}$$

$$\sigma_{\text{added}} + 6000 = 35\,000$$

$$\sigma_{\text{added}} = 29\,000 \text{ psi}$$

$$\frac{P_{\text{added}}}{2(4)} = 29\,000$$

$$P_{\text{added}} = 232\,000 \text{ lb}$$

$$P_{\text{added}} = 232 \text{ kips} \rightarrow \text{answer}$$

Solution to Problem 225 Biaxial Deformation

A welded steel cylindrical drum made of a 10-mm plate has an internal diameter of 1.20 m. Compute the change in diameter that would be caused by an internal pressure of 1.5 MPa. Assume that Poisson's ratio is 0.30 and $E = 200 \text{ GPa}$.

Solution 225

$\sigma_y =$ longitudinal stress

$$\sigma_y = \frac{pD}{4t} = \frac{1.5(1200)}{4(10)}$$

$$\sigma_y = 45 \text{ MPa}$$

$\sigma_x =$ tangential stress

$$\sigma_y = \frac{pD}{2t} = \frac{1.5(1200)}{2(10)}$$

$$\sigma_y = 90 \text{ MPa}$$

$$\epsilon_x = \frac{\sigma_x}{E} - \nu \frac{\sigma_y}{E}$$

$$\epsilon_x = \frac{90}{200\,000} - 0.3 \left(\frac{45}{200\,000} \right)$$

$$\epsilon_x = 3.825 \times 10^{-4}$$

$$\epsilon_x = \frac{\Delta D}{D}$$

$$\Delta D = \epsilon_x D = (3.825 \times 10^{-4})(1200)$$

$$\Delta D = 0.459 \text{ mm} \rightarrow \text{answer}$$

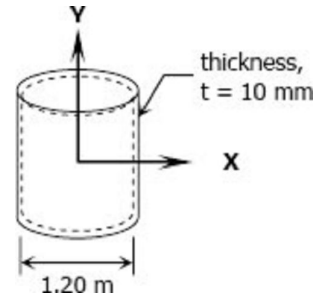

Solution to Problem 226 Biaxial Deformation

A 2-in.-diameter steel tube with a wall thickness of 0.05 inch just fits in a rigid hole. Find the tangential stress if an axial compressive load of 3140 lb is applied. Assume $\nu = 0.30$ and neglect the possibility of buckling.

Solution 226

$$\epsilon_x = \frac{\sigma_x}{E} - \nu \frac{\sigma_y}{E} = 0$$

where

$\sigma_x =$ tangential stress

$\sigma_y =$ longitudinal stress

$$\sigma_y = P_y / A = 3140 / (\pi \times 2 \times 0.05)$$

$$\sigma_y = 31,400 / \pi \text{ psi}$$

$$\sigma_x = 0.30(31400 / \pi)$$

$$\sigma_x = 9430 / \pi \text{ psi}$$

$$\sigma_x = 2298.5 \text{ psi}$$

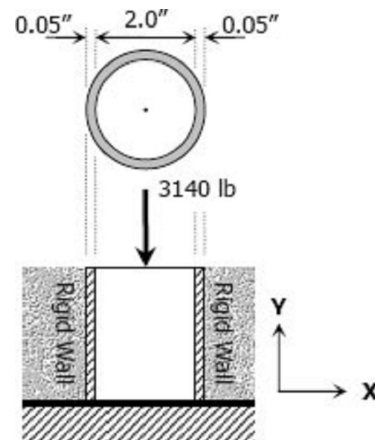

Solution to Problem 227 Biaxial Deformation

Problem 227

A 150-mm-long bronze tube, closed at its ends, is 80 mm in diameter and has a wall thickness of 3 mm. It fits without clearance in an 80-mm hole in a rigid block. The tube is then subjected to an internal pressure of 4.00 MPa. Assuming $\nu = 1/3$ and $E = 83$ GPa, determine the tangential stress in the tube.

Solution 227

Longitudinal stress:

$$\sigma_y = \frac{pD}{4t} = \frac{4(80)}{4(3)}$$

$$\sigma_y = \frac{80}{3} \text{ MPa}$$

The **strain in the x-direction** is:

$$\varepsilon_x = \frac{\sigma_x}{E} - \nu \frac{\sigma_y}{E} = 0$$

$$\sigma_x = \nu \sigma_y = \text{tangential stress}$$

$$\sigma_x = \frac{1}{3} \left(\frac{80}{3} \right)$$

$$\sigma_x = 8.89 \text{ MPa} \rightarrow \text{answer}$$

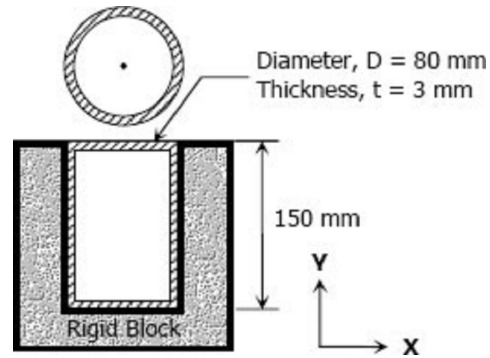

Solution to Problem 228 Biaxial Deformation

A 6-in.-long bronze tube, with closed ends, is 3 in. in diameter with a wall thickness of 0.10 in. With no internal pressure, the tube just fits between two rigid end walls. Calculate the longitudinal and tangential stresses for an internal pressure of 6000 psi. Assume $\nu = 1/3$ and $E = 12 \times 10^6$ psi.

Solution 228

$$\varepsilon = \frac{\sigma_x}{E} - \nu \frac{\sigma_y}{E} = 0$$

$$\sigma_x = \nu \sigma_y = \sigma_l \rightarrow \text{longitudinal stress}$$

$$\sigma_t = \sigma_y \rightarrow \text{tangential stress}$$

$$\sigma_t = \frac{pD}{2t} = \frac{6000(3)}{2(0.10)}$$

$$\sigma_t = 90\,000 \text{ psi} \rightarrow \text{answer}$$

$$\sigma_l = \nu \sigma_y = \frac{1}{3}(90\,000)$$

$$\sigma_l = 30\,000 \text{ psi} \rightarrow \text{answer}$$

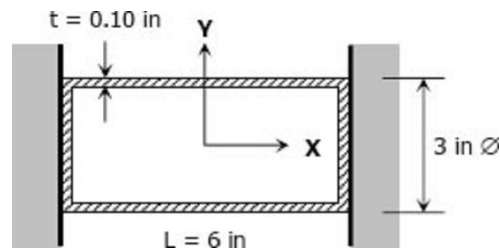

Statically Indeterminate Members

When the reactive forces or the internal resisting forces over a cross section exceed the number of independent equations of equilibrium, the structure is called statically indeterminate. These cases require the use of additional relations that depend on the elastic deformations in the members.

Solution to Problem 233 Statically Indeterminate

A steel bar 50 mm in diameter and 2 m long is surrounded by a shell of a cast iron 5 mm thick. Compute the load that will compress the combined bar a total of 0.8 mm in the length of 2 m. For steel, $E = 200$ GPa, and for cast iron, $E = 100$ GPa.

Solution 233

$$\delta = \frac{PL}{AE}$$

$$\delta = \delta_{cast\ iron} = \delta_{steel} = 0.8\text{ mm}$$

$$\delta_{cast\ iron} = \frac{P_{cast\ iron}(2000)}{[\frac{1}{4}\pi(60^2 - 50^2)](100\ 000)} = 0.8$$

$$P_{cast\ iron} = 11\ 000\pi\text{ N}$$

$$\delta_{steel} = \frac{P_{steel}(2000)}{[\frac{1}{4}\pi(50^2)](200\ 000)} = 0.8$$

$$P_{steel} = 50\ 000\pi\text{ N}$$

$$\Sigma F_V = 0$$

$$P = P_{cast\ iron} + P_{steel}$$

$$P = 11\ 000\pi + 50\ 000\pi$$

$$P = 61\ 000\pi\text{ N}$$

$$P = 191.64\text{ kN} \rightarrow \text{answer}$$

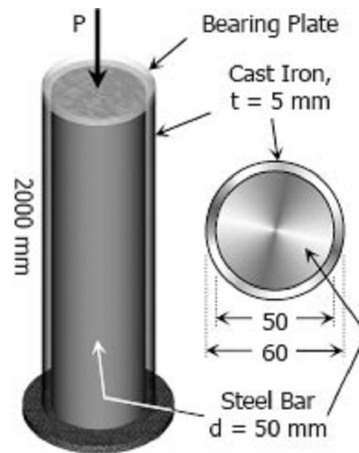

Solution to Problem 234 Statically Indeterminate

Problem 234

A reinforced concrete column 200 mm in diameter is designed to carry an axial compressive load of 300 kN. Determine the required area of the reinforcing steel if the allowable stresses are 6 MPa and 120 MPa for the concrete and steel, respectively. Use $E_{co} = 14$ GPa and $E_{st} = 200$ GPa.

Solution 234

$$\delta_{co} = \delta_{st} = \delta$$

$$\left(\frac{PL}{AE}\right)_{co} = \left(\frac{PL}{AE}\right)_{st}$$

$$\left(\frac{\sigma L}{E}\right)_{co} = \left(\frac{\sigma L}{E}\right)_{st}$$

$$\frac{\sigma_{co}L}{14000} = \frac{\sigma_{st}L}{200\ 000}$$

$$100\sigma_{co} = 7\sigma_{st}$$

When $\sigma_{st} = 120 \text{ MPa}$

$$100\sigma_{co} = 7(120)$$

$$\sigma_{co} = 8.4 \text{ MPa} > 6 \text{ MPa (not ok!)}$$

When $\sigma_{co} = 6 \text{ MPa}$

$$100(6) = 7\sigma_{st}$$

$$\sigma_{st} = 85.71 \text{ MPa} < 120 \text{ MPa (ok!)}$$

Use $\sigma_{co} = 6 \text{ MPa}$ and $\sigma_{st} = 85.71 \text{ MPa}$

$$\Sigma F_V = 0$$

$$P_{st} + P_{co} = 300$$

$$\sigma_{st} A_{st} + \sigma_{co} A_{co} = 300$$

$$85.71 A_{st} + 6 \left[\frac{1}{4} \pi (200)^2 - A_{st} \right] = 300(1000)$$

$$79.71 A_{st} + 60\,000\pi = 300\,000$$

$$A_{st} = 1398.9 \text{ mm}^2 \rightarrow \text{answer}$$

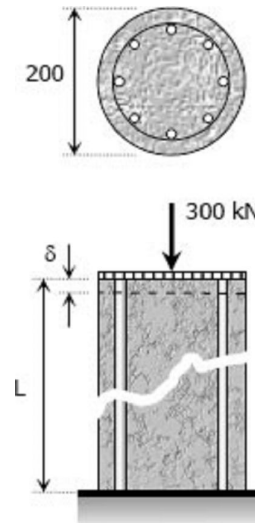

Solution to Problem 235 Statically Indeterminate

A timber column, 8 in. \times 8 in. in cross section, is reinforced on each side by a steel plate 8 in. wide and t in. thick. Determine the thickness t so that the column will support an axial load of 300 kips without exceeding a maximum timber stress of 1200 psi or a maximum steel stress of 20 ksi. The moduli of elasticity are 1.5×10^6 psi for timber, and 29×10^6 psi for steel.

Solution 235

$$\delta_{steel} = \delta_{timber}$$

$$\left(\frac{\sigma L}{E} \right)_{steel} = \left(\frac{\sigma L}{E} \right)_{timber}$$

$$\frac{\sigma_{steel} L}{29 \times 10^6} = \frac{\sigma_{timber} L}{1.5 \times 10^6}$$

$$1.5 \sigma_{steel} = 29 \sigma_{timber}$$

When $\sigma_{timber} = 1200 \text{ psi}$

$$1.5 \sigma_{steel} = 29(1200)$$

$$\sigma_{steel} = 23\,200 \text{ psi} = 23.2 \text{ ksi} > 20 \text{ ksi (not ok!)}$$

When $\sigma_{steel} = 20 \text{ ksi}$

$$1.5(20 \times 1000) = 29 \sigma_{timber}$$

$$\sigma_{timber} = 1034.48 \text{ psi} < 1200 \text{ psi (ok!)}$$

Use $\sigma_{steel} = 20 \text{ ksi}$ and $\sigma_{timber} = 1.03 \text{ ksi}$

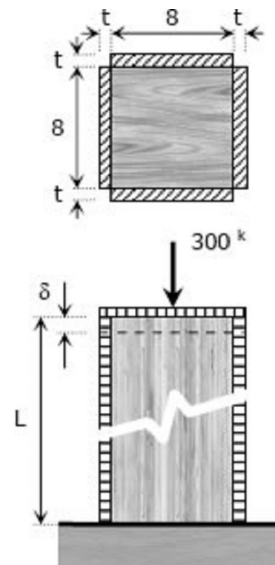

$$\Sigma F_V = 0$$

$$F_{steel} + F_{timber} = 300$$

$$(\sigma A)_{steel} + (\sigma A)_{timber} = 300$$

$$20 [4(8t)] + 1.03(82) = 300$$

$$t = 0.365 \text{ in} \rightarrow \text{answer}$$

Solution to Problem 236 Statically Indeterminate

A rigid block of mass M is supported by three symmetrically spaced rods as shown in Fig. P-236. Each copper rod has an area of 900 mm^2 ; $E = 120 \text{ GPa}$; and the allowable stress is 70 MPa . The steel rod has an area of 1200 mm^2 ; $E = 200 \text{ GPa}$; and the allowable stress is 140 MPa . Determine the largest mass M which can be supported.

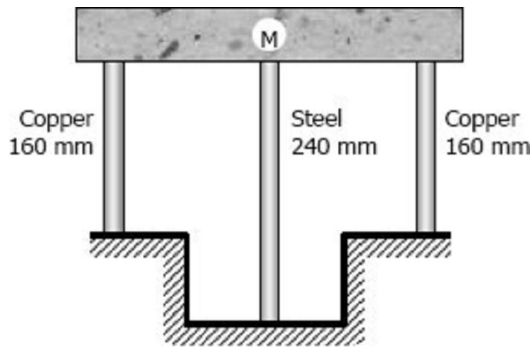
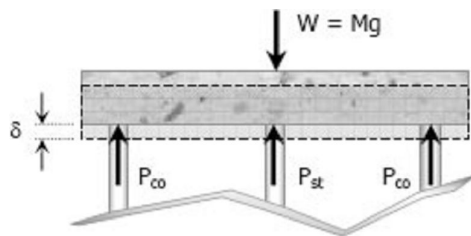

Figure P-236 and P-237

Solution 236



$$\delta_{co} = \delta_{st}$$

$$\left(\frac{\sigma L}{E} \right)_{co} = \left(\frac{\sigma L}{E} \right)_{st}$$

$$\frac{\sigma_{co} L}{120\,000} = \frac{\sigma_{st} L}{200\,000}$$

$$10\sigma_{co} = 9\sigma_{st}$$

When $\sigma_{st} = 140 \text{ MPa}$

$$\sigma_{co} = \frac{9}{10}(140)$$

$$\sigma_{co} = 126 \text{ MPa} > 70 \text{ MPa (not ok!)}$$

When $\sigma_{co} = 70 \text{ MPa}$

$$\sigma_{st} = \frac{10}{9}(70)$$

$$\sigma_{st} = 77.78 \text{ MPa} < 140 \text{ MPa (ok!)}$$

Use $\sigma_{co} = 70 \text{ MPa}$ and $\sigma_{st} = 77.78 \text{ MPa}$

$$\Sigma F_V = 0$$

$$2P_{co} + P_{st} = W$$

$$2(\sigma_{co} A_{co}) + \sigma_{st} A_{st} = Mg$$

$$2[70(900)] + 77.78(1200) = M(9.81)$$

$$M = 22358.4 \text{ kg} \rightarrow \text{answer}$$

Solution to Problem 237 Statically Indeterminate

In [Problem 236](#), how should the lengths of the two identical copper rods be changed so that each material will be stressed to its allowable limit?

Solution 237

Use $\sigma_{co} = 70 \text{ MPa}$ and $\sigma_{st} = 140 \text{ MPa}$

$$\delta_{co} = \delta_{st}$$

$$\left(\frac{\sigma L}{E}\right)_{co} = \left(\frac{\sigma L}{E}\right)_{st}$$

$$\frac{70L_{co}}{120\,000} = \frac{140(240)}{200\,000}$$

$$L_{co} = 288 \text{ mm answer}$$

Solution to Problem 238 Statically Indeterminate

Problem 238

The lower ends of the three bars in Fig. P-238 are at the same level before the uniform rigid block weighing 40 kips is attached. Each steel bar has a length of 3 ft, and area of 1.0 in.^2 , and $E = 29 \times 10^6 \text{ psi}$. For the bronze bar, the area is 1.5 in.^2 and $E = 12 \times 10^6 \text{ psi}$. Determine (a) the length of the bronze bar so that the load on each steel bar is twice the load on the bronze bar, and (b) the length of the bronze that will make the steel stress twice the bronze stress.

Figure P-238

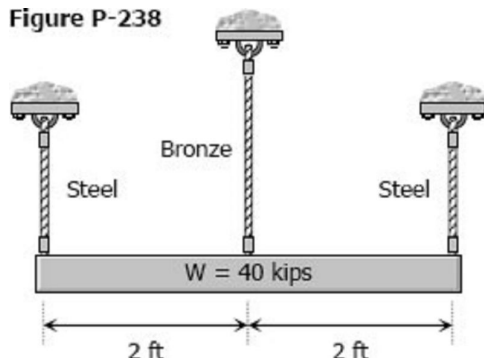

Solution 238

(a) Condition: $P_{st} = 2P_{br}$

$$\Sigma F_V = 0$$

$$2P_{st} + P_{br} = 40$$

$$2(2P_{br}) + P_{br} = 40$$

$$P_{br} = 8 \text{ kips}$$

$$P_{st} = 2(8) = 16 \text{ kips}$$

$$\delta_{br} = \delta_{st}$$

$$\left(\frac{PL}{AE}\right)_{br} = \left(\frac{PL}{AE}\right)_{st}$$

$$\frac{8000 L_{br}}{1.5(12 \times 10^6)} = \frac{16000(3 \times 12)}{1.0(29 \times 10^6)}$$

$$L_{br} = 44.69 \text{ in}$$

$$L_{br} = 3.72 \text{ ft} \rightarrow \text{answer}$$

(b) Condition: $\sigma_{st} = 2\sigma_{br}$

$$\Sigma F_V = 0$$

$$2P_{st} + P_{br} = 40$$

$$2(\sigma_{st} A_{st}) + \sigma_{br} A_{br} = 40$$

$$2[(2\sigma_{br}) A_{st}] + \sigma_{br} A_{br} = 40$$

$$4\sigma_{br}(1.0) + \sigma_{br}(1.5) = 40$$

$$\sigma_{br} = 7.27 \text{ ksi}$$

$$\sigma_{st} = 2(7.27) = 14.54 \text{ ksi}$$

$$\delta_{br} = \delta_{st}$$

$$\left(\frac{\sigma L}{E}\right)_{br} = \left(\frac{\sigma L}{E}\right)_{st}$$

$$\frac{7.27(1000) L_{br}}{12 \times 10^6} = \frac{14.54(1000)(3 \times 12)}{29 \times 10^6}$$

$$L_{br} = 29.79 \text{ in}$$

$$L_{br} = 2.48 \text{ ft} \rightarrow \text{answer}$$

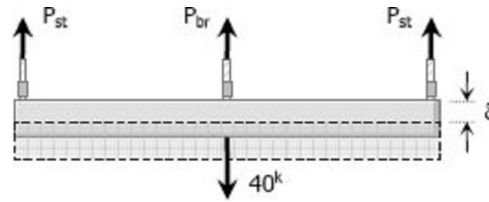

Solution to Problem 239 Statically Indeterminate

The rigid platform in Fig. P-239 has negligible mass and rests on two steel bars, each 250.00 mm long. The center bar is aluminum and 249.90 mm long. Compute the stress in the aluminum bar after the center load $P = 400 \text{ kN}$ has been applied. For each steel bar, the area is 1200 mm^2 and $E = 200 \text{ GPa}$. For the aluminum bar, the area is 2400 mm^2 and $E = 70 \text{ GPa}$.

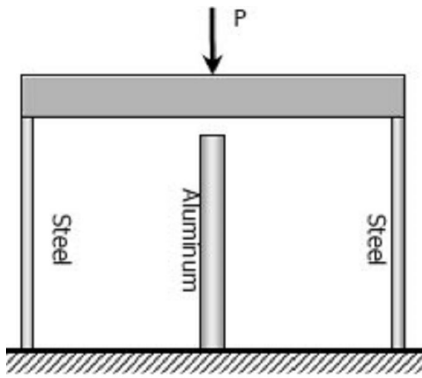
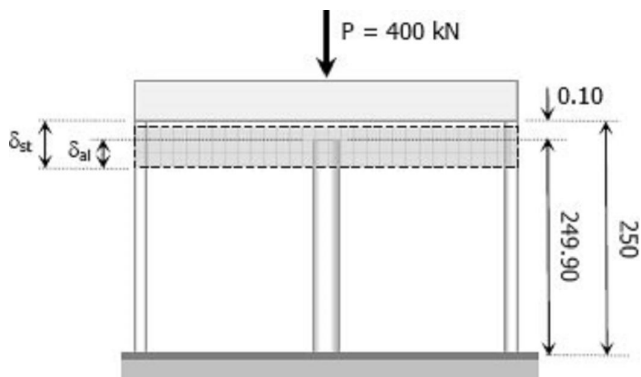

Figure P-239

Solution 239



$$\delta_{st} = \delta_{al} + 0.10$$

$$\left(\frac{\sigma L}{E}\right)_{st} = \left(\frac{\sigma L}{E}\right)_{al} + 0.10$$

$$\frac{\sigma_{st}(250)}{200\,000} = \frac{\sigma_{al}(249.90)}{70\,000} + 0.10$$

$$0.00125\sigma_{st} = 0.00357\sigma_{al} + 0.10$$

$$\sigma_{st} = 2.856\sigma_{al} + 80$$

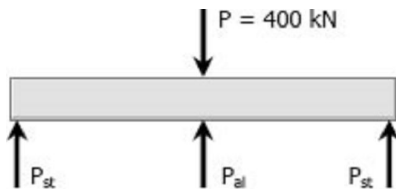

$$\Sigma F_V = 0$$

$$2P_{st} + P_{al} = 400\,000$$

$$2\sigma_{st}A_{st} + \sigma_{al}A_{al} = 400\,000$$

$$2(2.856\sigma_{al} + 80)1200 + \sigma_{al}(2400) = 400\,000$$

$$9254.4\sigma_{al} + 192\,000 = 400\,000$$

$$\sigma_{al} = 22.48 \text{ MPa} \rightarrow \text{answer}$$

Solution to Problem 240 Statically Indeterminate

Problem 240

Three steel eye-bars, each 4 in. by 1 in. in section, are to be assembled by driving rigid 7/8-in.-diameter drift pins through holes drilled in the ends of the bars. The center-line spacing between the holes is 30 ft in the two outer bars, but 0.045 in. shorter in the middle bar. Find the shearing stress developed in the drip pins. Neglect local deformation at the holes.

Solution 240

Middle bar is 0.045 inch shorter between holes than outer bars.

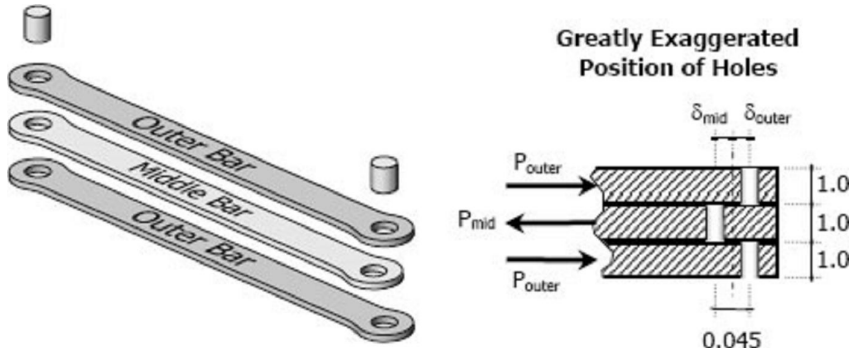

$$\Sigma F_H = 0$$

$$P_{mid} = 2P_{outer}$$

$$\delta_{outer} + \delta_{mid} = 0.045$$

$$\left(\frac{PL}{AE}\right)_{outer} + \left(\frac{PL}{AE}\right)_{mid} = 0.045$$

$$\frac{P_{outer}(30 \times 12)}{[1.0(4.0)]E} + \frac{P_{mid}(30 \times 12 - 0.045)}{[1.0(4.0)]E} = 0.045$$

$$360P_{outer} + 359.955P_{mid} = 0.18E$$

$$360P_{outer} + 359.955(2P_{outer}) = 0.18E$$

(For steel: $E = 29 \times 10^6$ psi)

$$1079.91P_{outer} = 0.18(29 \times 10^6)$$

$$P_{outer} = 4833.74 \text{ lb}$$

$$P_{mid} = 2(4833.74)$$

$$P_{mid} = 9667.48 \text{ lb}$$

Use shear force $V = P_{mid}$

Shearing stress of drip pins (double shear):

$$\tau = \frac{V}{A} = \frac{9667.48}{2 \left[\frac{1}{4} \pi \left(\frac{7}{8} \right)^2 \right]}$$

$$\tau = 8038.54 \text{ psi} \rightarrow \text{answer}$$

Solution to Problem 241 Statically Indeterminate

As shown in Fig. P-241, three steel wires, each 0.05 in.² in area, are used to lift a load $W = 1500$ lb. Their unstressed lengths are 74.98 ft, 74.99 ft, and 75.00 ft.

- (a) What stress exists in the longest wire?
 (b) Determine the stress in the shortest wire if $W = 500$ lb.



Figure P-241

Solution 241

Let $L_1 = 74.98$ ft; $L_2 = 74.99$ ft; and $L_3 = 75.00$ ft

Part (a)

Bring L_1 and L_2 into $L_3 = 75$ ft length:

(For steel: $E = 29 \times 10^6$ psi)

$$\delta = \frac{PL}{AE}$$

For L_1 :

$$(75 - 74.98)(12) = \frac{P_1(74.98 \times 12)}{0.05(29 \times 10^6)}$$

$$P_1 = 386.77 \text{ lb}$$

For L_2 :

$$(75 - 74.99)(12) = \frac{P_2(74.99 \times 12)}{0.05(29 \times 10^6)}$$

$$P_2 = 193.36 \text{ lb}$$

Let $P = P_3$ (Load carried by L_3)

$P + P_2$ (Total load carried by L_2)

$P + P_1$ (Total load carried by L_1)

$$\Sigma F_V = 0$$

$$(P + P_1) + (P + P_2) + P = W$$

$$3P + 386.77 + 193.36 = 1500$$

$$P = 306.62 \text{ lb} = P_3$$

$$\sigma_3 = \frac{P_3}{A} = \frac{306.62}{0.05}$$

$$\sigma_3 = 6132.47 \text{ psi} \rightarrow \text{answer}$$

Part (b)

From the above solution:

$$P_1 + P_2 = 580.13 \text{ lb} > 500 \text{ lb} \text{ (} L_3 \text{ carries no load)}$$

Bring L_1 into $L_2 = 74.99$ ft

$$\delta = \frac{PL}{AE}$$

$$(74.99 - 74.98)(12) = \frac{P_1(74.98 \times 12)}{0.05(29 \times 10^6)}$$

$$P_1 = 193.38 \text{ lb}$$

Let $P = P_2$ (Load carried by L_2)

$P + P_1$ (Total load carried by L_1)

$$\Sigma F_V = 0$$

$$(P + P_1) + P = 500$$

$$2P + 193.38 = 500$$

$$P = 153.31 \text{ lb}$$

$$P + P_1 = 153.31 + 193.38$$

$$P + P_1 = 346.69 \text{ lb}$$

$$\sigma = \frac{P + P_1}{A} = \frac{346.69}{0.05}$$

$$\sigma = 6933.8 \text{ psi} \rightarrow \text{answer}$$

Solution to Problem 242 Statically Indeterminate

The assembly in Fig. P-242 consists of a light rigid bar AB, pinned at O, that is attached to the steel and aluminum rods. In the position shown, bar AB is horizontal and there is a gap, $\Delta = 5$ mm, between the lower end of the steel rod and its pin support at C. Compute the stress in the aluminum rod when the lower end of the steel rod is attached to its support.

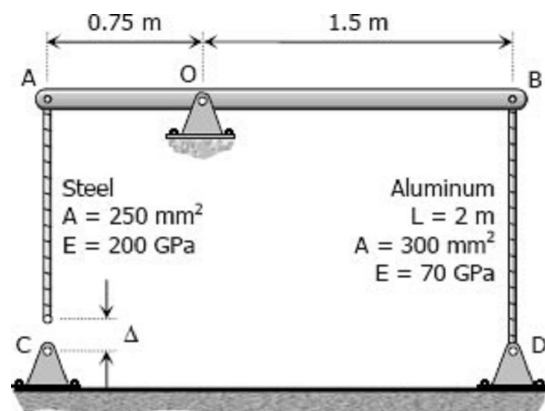
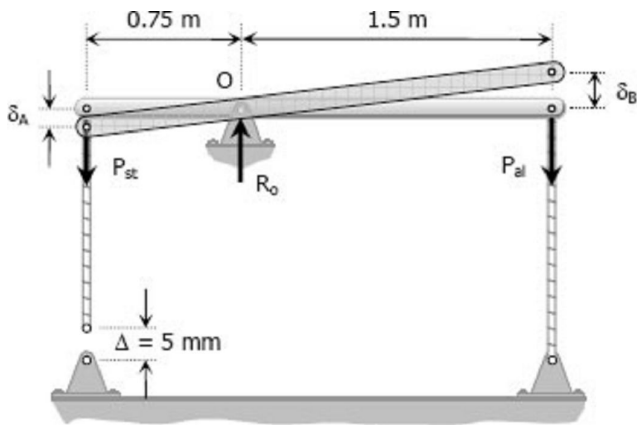

Figure P-242

Solution 242



$$\Sigma M_O = 0$$

$$0.75P_{st} = 1.5P_{al}$$

$$P_{st} = 2P_{al}$$

$$\sigma_{st}A_{st} = 2(\sigma_{al}A_{al})$$

$$\sigma_{st} = \frac{2\sigma_{al}A_{al}}{A_{st}}$$

$$\sigma_{st} = \frac{2[\sigma_{al}(3000)]}{250}$$

$$\sigma_{st} = 2.4\sigma_{al}$$

$$\delta_{al} = \delta_B$$

By ratio and proportion:

$$\frac{\delta_A}{0.75} = \frac{\delta_B}{1.5}$$

$$\delta_A = 0.5\delta_B$$

$$\delta_A = 0.5\delta_{al}$$

$$\Delta = \delta_{st} + \delta_A$$

$$5 = \delta_{st} + 0.5\delta_{al}$$

$$5 = \frac{\sigma_{st}(2000-5)}{250(200000)} + 0.5 \left[\frac{\sigma_{al}(2000)}{300(70000)} \right]$$

$$5 = (3.99 \times 10^{-5})\sigma_{st} + (4.76 \times 10^{-5})\sigma_{al}$$

$$\sigma_{al} = 105000 - 0.8379\sigma_{st}$$

$$\sigma_{al} = 105000 - 0.8379(2.4\sigma_{al})$$

$$3.01096\sigma_{al} = 105000$$

$$\sigma_{al} = 34872.6 \text{ MPa} \rightarrow \text{answer}$$

Solution to Problem 243 Statically Indeterminate

A homogeneous rod of constant cross section is attached to unyielding supports. It carries an axial load P applied as shown in Fig. P-243. Prove that the reactions are given by $R_1 = Pb/L$ and $R_2 = Pa/L$.

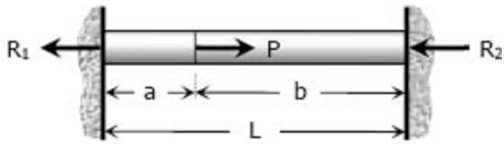

Figure P-243

Solution 243

$$\sum F_H = 0$$

$$R_1 + R_2 = P$$

$$R_2 = P - R_1$$

$$\delta_1 = \delta_2 = \delta$$

$$\left(\frac{PL}{AE}\right)_1 = \left(\frac{PL}{AE}\right)_2$$

$$\frac{R_1 a}{AE} = \frac{R_2 b}{AE}$$

$$R_1 a = R_2 b$$

$$R_1 a = (P - R_1)b$$

$$R_1 a = Pb - R_1 b$$

$$R_1 (a + b) = Pb$$

$$R_1 L = Pb$$

$$R_1 = Pb/L \text{ ok!}$$

$$R_2 = P - Pb/L$$

$$R_2 = \frac{P(L - b)}{L}$$

$$R_2 = Pa/L \text{ ok!}$$

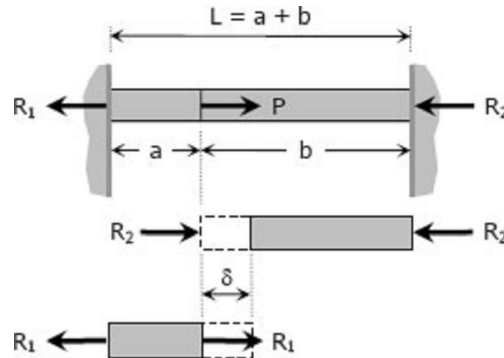

Solution to Problem 244 Statically Indeterminate

A homogeneous bar with a cross sectional area of 500 mm^2 is attached to rigid supports. It carries the axial loads $P_1 = 25 \text{ kN}$ and $P_2 = 50 \text{ kN}$, applied as shown in Fig. P-244. Determine the stress in segment BC. (Hint: Use the results of Prob. 243, and compute the reactions caused by P_1 and P_2 acting separately. Then use the principle of superposition to compute the reactions when both loads are applied.)

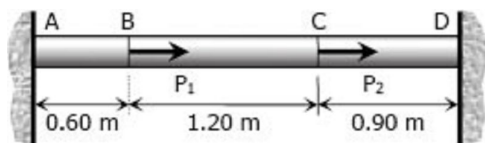

Figure P-244



Solution 244

From the results of [Solution to Problem 243](#):

$$R_1 = 25(2.10)/2.70$$

$$R_1 = 19.44 \text{ kN}$$

$$R_2 = 50(0.90)/2.70$$

$$R_2 = 16.67 \text{ kN}$$

$$R_A = R_1 + R_2$$

$$R_A = 19.44 + 16.67$$

$$R_A = 36.11 \text{ kN}$$

For segment BC

$$P_{BC} + 25 = R_A$$

$$P_{BC} + 25 = 36.11$$

$$P_{BC} = 11.11 \text{ kN}$$

$$\sigma_{BC} = \frac{P_{BC}}{A} = \frac{11.11(1000)}{500}$$

$$\sigma_{BC} = 22.22 \text{ MPa} \rightarrow \text{answer}$$

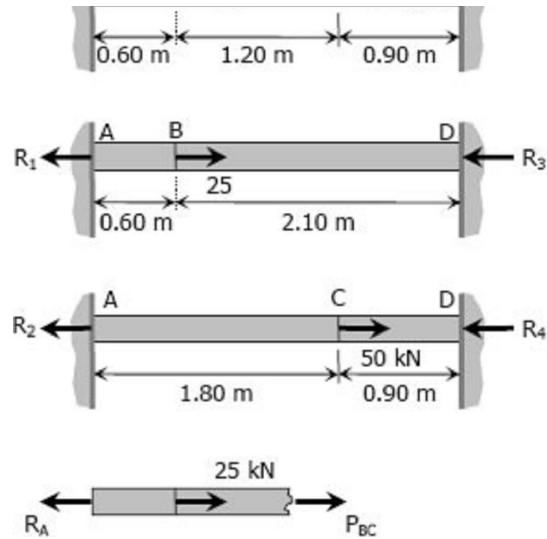

Solution to Problem 245 Statically Indeterminate

The composite bar in Fig. P-245 is firmly attached to unyielding supports. Compute the stress in each material caused by the application of the axial load $P = 50$ kips.

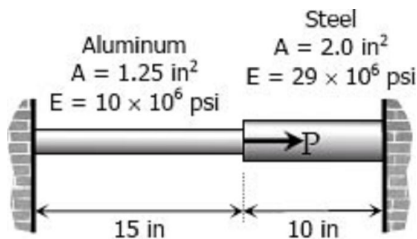

Figure P-245 and P-246

Solution 245

$$\Sigma F_H = 0$$

$$R_1 + R_2 = 50\,000$$

$$R_1 = 50\,000 - R_2$$

$$\delta_{al} = \delta_{st} = \delta$$

$$\left(\frac{PL}{AE}\right)_{al} = \left(\frac{PL}{AE}\right)_{st}$$

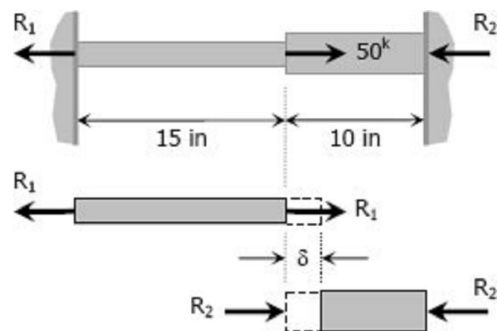

$$\frac{R_1 (15)}{1.25(10 \times 10^6)} = \frac{R_2 (10)}{2.0(29 \times 10^6)}$$

$$R_2 = 6.96R_1$$

$$R_2 = 6.96(50\,000 - R_2)$$

$$7.96R_2 = 348\,000$$

$$R_2 = 43\,718.59 \text{ lb}$$

$$\sigma_{st} = \frac{R_2}{A_{st}} = \frac{43\,718.59}{2.0}$$

$$\sigma_{st} = 21\,859.30 \text{ psi} \rightarrow \text{answer}$$

$$R_1 = 50\,000 - 43\,718.59$$

$$R_1 = 6\,281.41 \text{ lb}$$

$$\sigma_{al} = \frac{R_1}{A_{al}} = \frac{6\,281.41}{1.25}$$

$$\sigma_{al} = 5\,025.12 \text{ psi} \rightarrow \text{answer}$$

Solution to Problem 246 Statically Indeterminate

Referring to the composite bar in [Problem 245](#), what maximum axial load P can be applied if the allowable stresses are 10 ksi for aluminum and 18 ksi for steel.

Solution 246

$$\delta_{st} = \delta_{al} = \delta$$

$$\left(\frac{\sigma L}{E}\right)_{st} = \left(\frac{\sigma L}{E}\right)_{al}$$

$$\frac{\sigma_{st}(10)_{st}}{29 \times 10^6} = \frac{\sigma_{al}(15)_{al}}{10 \times 10^6}$$

$$\sigma_{st} = 4.35 \sigma_{al}$$

When $\sigma_{al} = 10 \text{ ksi}$

$$\sigma_{st} = 4.35(10)$$

$$\sigma_{st} = 43.5 \text{ ksi} > 18 \text{ ksi (not ok!)}$$

When $\sigma_{st} = 18 \text{ ksi}$

$$18 = 4.35 \sigma_{al}$$

$$\sigma_{al} = 4.14 \text{ ksi} < 10 \text{ ksi (ok!)}$$

Use $\sigma_{al} = 4.14 \text{ ksi}$ and $\sigma_{st} = 18 \text{ ksi}$

$$\Sigma F_H = 0$$

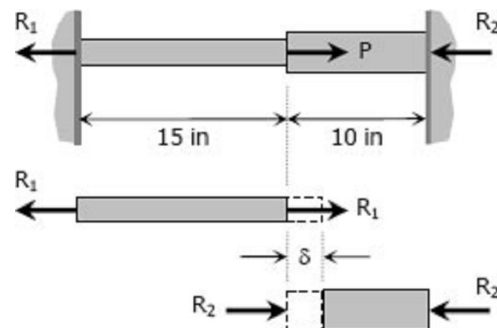

$$P = R_1 + R_2$$

$$P = \sigma_{al} A_{al} + \sigma_{st} A_{st}$$

$$P = 4.14(1.25) + 18(2.0)$$

$$P = 41.17 \text{ kips} \rightarrow \text{answer}$$

Solution to Problem 247 Statically Indeterminate

The composite bar in Fig. P-247 is stress-free before the axial loads P_1 and P_2 are applied. Assuming that the walls are rigid, calculate the stress in each material if $P_1 = 150 \text{ kN}$ and $P_2 = 90 \text{ kN}$.

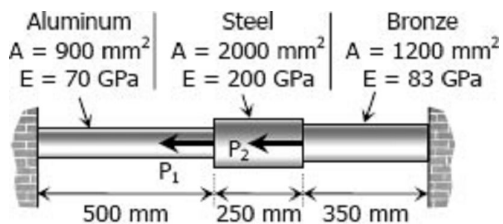

Figure P-247 and P-248

Solution 247

From the FBD of each material shown:

δ_{al} is shortening

δ_{st} and δ_{br} are lengthening

$$R_2 = 240 - R_1$$

$$P_{al} = R_1$$

$$P_{st} = 150 - R_1$$

$$P_{br} = R_2 = 240 - R_1$$

$$\delta_{al} = \delta_{st} + \delta_{br}$$

$$\left(\frac{PL}{AE}\right)_{al} = \left(\frac{PL}{AE}\right)_{st} + \left(\frac{PL}{AE}\right)_{br}$$

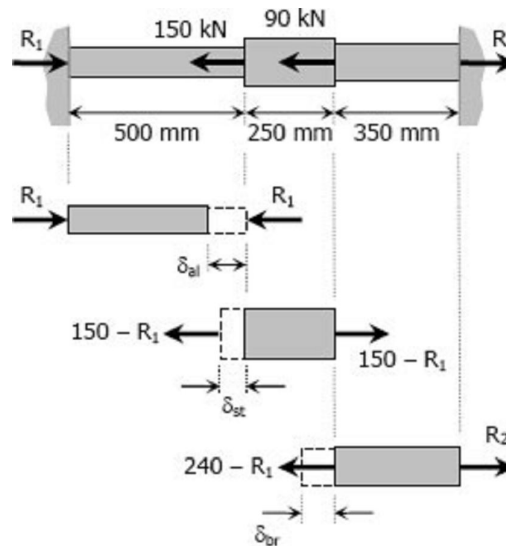

$$\frac{R_1(500)}{900(70\,000)} = \frac{(150-R_1)(250)}{2000(200\,000)} + \frac{(240-R_1)(350)}{1200(83\,000)}$$

$$\frac{R_1}{126\,000} = \frac{150-R_1}{1\,600\,000} + \frac{(240-R_1)7}{1\,992\,000}$$

$$\frac{1}{63}R_1 = \frac{1}{800}(150 - R_1) + \frac{7}{996}(240 - R_1)$$

$$\left(\frac{1}{63} + \frac{1}{800} + \frac{7}{996}\right)R_1 = \frac{1}{800}(150) + \frac{7}{996}(240)$$

$$R_1 = 77.60 \text{ kN}$$

$$P_{al} = R_1 = 77.60 \text{ kN}$$

$$P_{st} = 150 - 77.60 = 72.40 \text{ kN}$$

$$P_{br} = 240 - 77.60 = 162.40 \text{ kN}$$

$$\sigma = P/A$$

$$\sigma_{al} = 77.60(1000)/900$$

$$\sigma_{al} = 86.22 \text{ MPa} \rightarrow \text{answer}$$

$$\sigma_{st} = 72.40(1000)/2000$$

$$\sigma_{st} = 36.20 \text{ MPa} \rightarrow \text{answer}$$

$$\sigma_{br} = 162.40(1000)/1200$$

$$\sigma_{br} = 135.33 \text{ MPa} \rightarrow \text{answer}$$

Solution to Problem 248 Statically Indeterminate

Solve [Problem 247](#) if the right wall yields 0.80 mm.

Solution 248

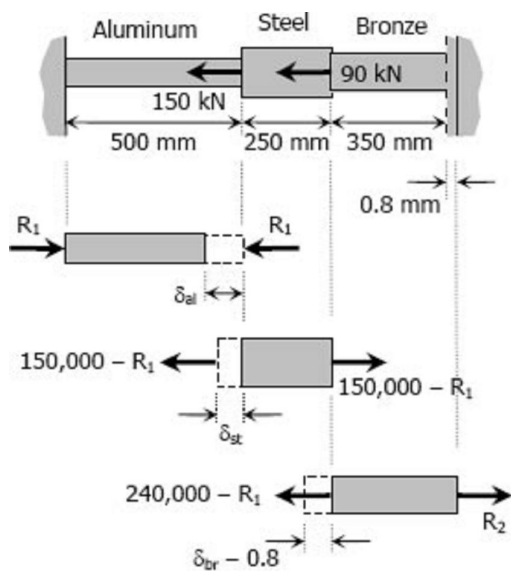

$$\delta_{al} = \delta_{st} + (\delta_{br} + 0.8)$$

$$\left(\frac{PL}{AE}\right)_{al} = \left(\frac{PL}{AE}\right)_{st} + \left(\frac{PL}{AE}\right)_{br} + 0.8$$

$$\frac{R_1(500)}{900(70\,000)} = \frac{(150\,000 - R_1)(250)}{2000(200\,000)} + \frac{(240\,000 - R_1)(350)}{1200(83\,000)} + 0.8$$

$$\frac{R_1}{126\,000} = \frac{150\,000 - R_1}{1\,600\,000} + \frac{7(240\,000 - R_1)}{1\,992\,000} + 0.8$$

$$\frac{1}{63}R_1 = \frac{1}{800}(150\,000 - R_1) + \frac{7}{996}(240\,000 - R_1) + 1600$$

$$\left(\frac{1}{63} + \frac{1}{800} + \frac{7}{996}\right)R_1 = \frac{1}{800}(150\,000) + \frac{7}{996}(240\,000) + 1600$$

$$R_1 = 143\,854 \text{ N} = 143.854 \text{ kN}$$

$$P_{al} = R_1 = 143.854 \text{ kN}$$

$$P_{st} = 150 - R_1 = 150 - 143.854 = 6.146 \text{ kN}$$

$$P_{br} = R_2 = 240 - R_1 = 240 - 143.854 = 96.146 \text{ kN}$$

$$\sigma = P/A$$

$$\sigma_{al} = 143.854(1000)/900$$

$$\sigma_{al} = 159.84 \text{ MPa} \rightarrow \text{answer}$$

$$\sigma_{st} = 6.146(1000)/2000$$

$$\sigma_{st} = 3.073 \text{ MPa} \rightarrow \text{answer}$$

$$\sigma_{br} = 96.146(1000)/1200$$

$$\sigma_{br} = 80.122 \text{ MPa} \rightarrow \text{answer}$$

Solution to Problem 249 Statically Indeterminate

There is a radial clearance of 0.05 mm when a steel tube is placed over an aluminum tube. The inside diameter of the aluminum tube is 120 mm, and the wall thickness of each tube is 2.5 mm. Compute the contact pressure and tangential stress in each tube when the aluminum tube is subjected to an internal pressure of 5.0 MPa.

Solution 249

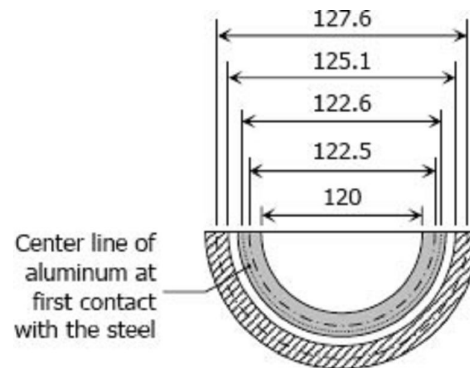
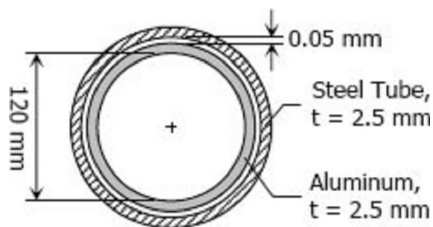

Internal pressure of aluminum tube to cause contact with the steel:

$$\delta_{al} = \left(\frac{\sigma L}{E} \right)_{al}$$

$$\pi(122.6 - 122.5) = \frac{\sigma_1 (122.5\pi)}{70000}$$

$$\sigma_1 = 57.143 \text{ MPa}$$

$$\frac{p_1 D}{2t} = 57.143$$

$$\frac{p_1(120)}{2(2.5)} = 57.143$$

$$p_1 = 2.381 \text{ MPa} \rightarrow \text{pressure that causes aluminum to contact with the steel, further increase of}$$

pressure will expand both aluminum and steel tubes.

Let p_c = contact pressure between steel and aluminum tubes

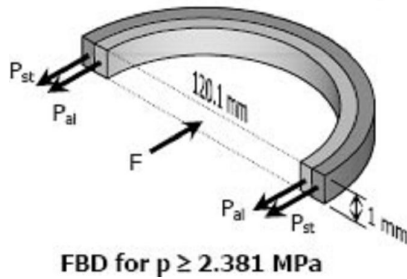

$$2P_{st} + 2P_{al} = F$$

$$2P_{st} + 2P_{al} = 5.0(120.1)(1)$$

$$P_{st} + P_{al} = 300.25 \rightarrow \text{Equation (1)}$$

The relationship of deformations is (from the figure):

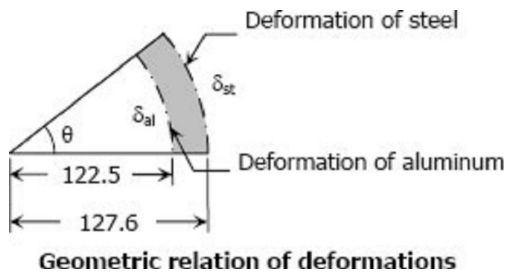

$$\delta_{st} = 127.6\theta$$

$$\theta = \delta_{st}/127.6$$

$$\delta_{al} = 122.5\theta$$

$$\delta_{al} = 122.5(\delta_{st}/127.6)$$

$$\delta_{al} = 0.96 \delta_{st}$$

$$\left(\frac{PL}{AE}\right)_{al} = 0.96 \left(\frac{PL}{AE}\right)_{st}$$

$$\frac{P_{al}(122.5\pi)}{2.5(70\,000)} = 0.96 \left[\frac{P_{st}(127.6)}{2.5(200\,000)} \right]$$

$$P_{al} = 0.35P_{st} \rightarrow \text{Equation (2)}$$

From Equation (1)

$$P_{st} + 0.35P_{st} = 300.25$$

$$P_{st} = 222.41 \text{ N}$$

$$P_{al} = 0.35(222.41)$$

$$P_{al} = 77.84 \text{ N}$$

Contact Force

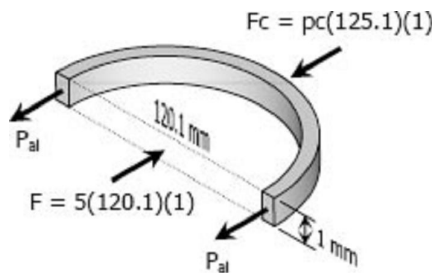

$$F_c + 2P_{st} = F$$

$$p_c(125.1)(1) + 2(77.84) = 5(120.1)(1)$$

$$p_c = 3.56 \text{ MPa} \rightarrow \text{answer}$$

Solution to Problem 250 Statically Indeterminate

In the assembly of the bronze tube and steel bolt shown in Fig. P-250, the pitch of the bolt thread is $p = 1/32$ in.; the cross-sectional area of the bronze tube is 1.5 in.^2 and of steel bolt is $3/4 \text{ in.}^2$. The nut is turned until there is a compressive stress of 4000 psi in the bronze tube. Find the stresses if the nut is given one additional turn. How many turns of the nut will reduce these stresses to zero? Use $E_{br} = 12 \times 10^6$ psi and $E_{st} = 29 \times 10^6$ psi.

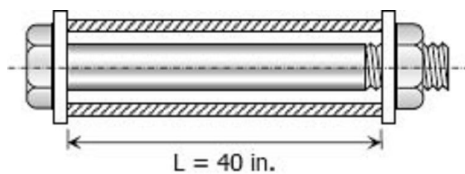
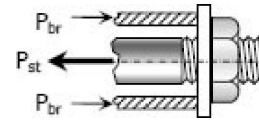

Figure P-250

Solution 250

$$\begin{aligned}P_{st} &= P_{br} \\A_{st} \sigma_{st} &= P_{br} \sigma_{br} \\\frac{3}{4} \sigma_{st} &= 1.5 \sigma_{br} \\\sigma_{st} &= 2\sigma_{br}\end{aligned}$$



For one turn of the nut:

$$\begin{aligned}\delta_{st} + \delta_{br} &= \frac{1}{32} \\ \left(\frac{\sigma L}{E} \right)_{st} + \left(\frac{\sigma L}{E} \right)_{br} &= \frac{1}{32} \\ \frac{\sigma_{st}(40)}{29 \times 10^6} + \frac{\sigma_{br}(40)}{12 \times 10^6} &= \frac{1}{32} \\ \sigma_{st} + \frac{29}{12} \sigma_{br} &= 22\,656.25 \\ 2\sigma_{br} + \frac{29}{12} \sigma_{br} &= 22\,656.25 \\ \sigma_{br} &= 5129.72 \text{ psi} \\ \sigma_{st} &= 2(5129.72) = 10259.43 \text{ psi}\end{aligned}$$

Initial stresses:

$$\begin{aligned}\sigma_{br} &= 4000 \text{ psi} \\ \sigma_{st} &= 2(4000) = 8000 \text{ psi}\end{aligned}$$

Final stresses:

$$\begin{aligned}\sigma_{br} &= 4000 + 5129.72 = 9\,129.72 \text{ psi} \rightarrow \text{answer} \\ \sigma_{st} &= 2(9129.72) = 18\,259.4 \text{ psi} \rightarrow \text{answer}\end{aligned}$$

Required number of turns to reduce σ_{br} to zero:

$$n = \frac{9129.72}{5129.72} = 1.78 \text{ turns}$$

The nut must be turned back by **1.78 turns**

Solution to Problem 251 Statically Indeterminate

The two vertical rods attached to the light rigid bar in [Fig. P-251](#) are identical except for length. Before the load W was attached, the bar was horizontal and the rods were stress-free. Determine the load in each

rod if $W = 6600$ lb.

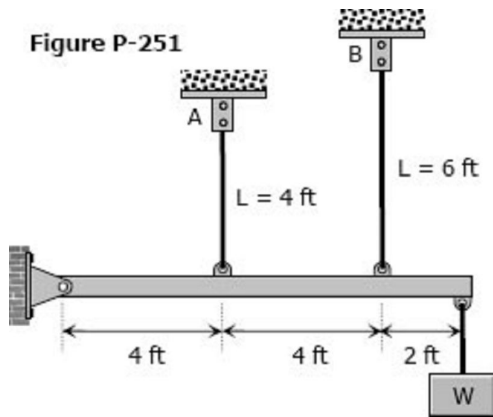

Solution 251

$$\sum M_{pin\ support} = 0$$

$$4P_A + 8P_B = 10(6600)$$

$$P_A + 2P_B = 16500 \rightarrow \text{equation (1)}$$

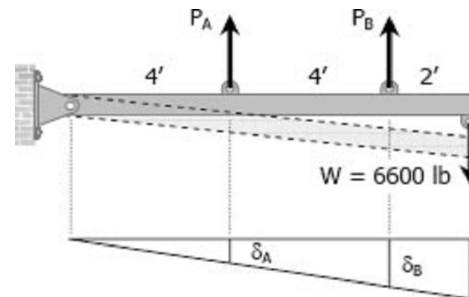

By ratio and proportion

$$\frac{\delta_A}{4} = \frac{\delta_B}{8}$$

$$\delta_A = 0.5\delta_B$$

$$\left(\frac{PL}{AE}\right)_A = 0.5\left(\frac{PL}{AE}\right)_B$$

$$\frac{P_A(4)}{AE} = \frac{0.5P_B(4)}{AE}$$

$$P_A = 0.75P_B$$

From equation (1)

$$0.75P_B + 2P_B = 16500$$

$$P_B = 6000 \text{ lb} \rightarrow \text{answer}$$

$$P_A = 0.75(6000)$$

$$P_A = 4500 \text{ lb} \rightarrow \text{answer}$$

Solution to Problem 252 Statically Indeterminate

Problem 252

The light rigid bar ABCD shown in Fig. P-252 is pinned at B and connected to two vertical rods. Assuming that the bar was initially horizontal and the rods stress-free, determine the stress in each rod after the load $P = 20$ kips is applied.

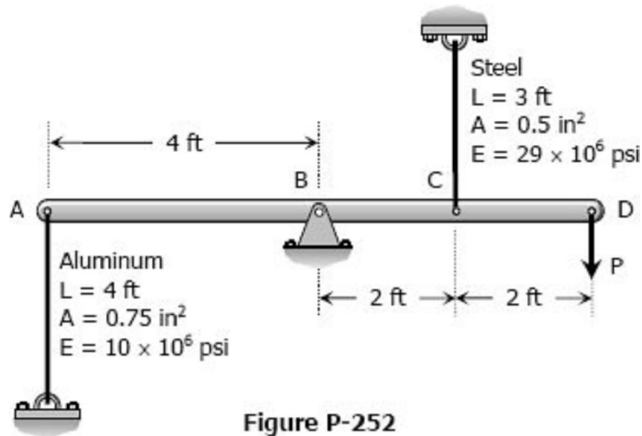

Solution 252

$$\begin{aligned} \sum M_B &= 0 \\ 4P_{al} + 2P_{st} &= 4(20\,000) \\ 4(\sigma_{al}A_{al}) + 2\sigma_{st}A_{st} &= 80\,000 \\ 4[\sigma_{al}(0.75)] + 2[\sigma_{st}(0.5)] &= 80\,000 \\ 3\sigma_{al} + \sigma_{st} &= 80\,000 \rightarrow \text{equation (1)} \end{aligned}$$

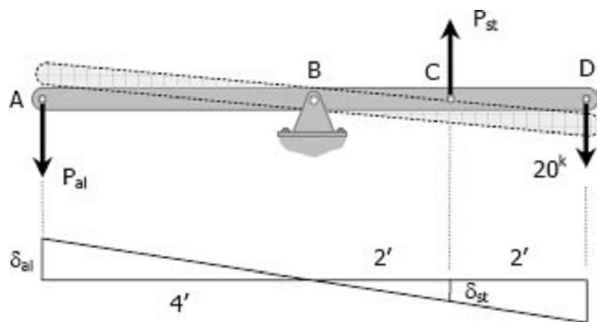

$$\begin{aligned} \frac{\delta_{st}}{2} &= \frac{\delta_{al}}{4} \\ \delta_{st} &= 0.5\delta_{al} \\ \left(\frac{\sigma L}{E}\right)_{st} &= 0.5 \left(\frac{\sigma L}{E}\right)_{al} \end{aligned}$$

$$\frac{\sigma_{st}(3)}{29 \times 10^6} = 0.5 \left[\frac{\sigma_{al}(4)}{10 \times 10^6} \right]$$

$$\sigma_{st} = \frac{29}{15} \sigma_{al}$$

From equation (1)

$$3\sigma_{al} + \frac{29}{15}\sigma_{al} = 80\,000$$

$$\sigma_{al} = 16\,216.22 \text{ psi}$$

$$\sigma_{al} = 16.22 \text{ ksi} \rightarrow \text{answer}$$

$$\sigma_{st} = \frac{29}{15}(16.22)$$

$$\sigma_{st} = 31.35 \text{ ksi} \rightarrow \text{answer}$$

Solution to Problem 253 Statically Indeterminate

As shown in [Fig. P-253](#), a rigid beam with negligible weight is pinned at one end and attached to two vertical rods. The beam was initially horizontal before the load $W = 50$ kips was applied. Find the vertical movement of W .

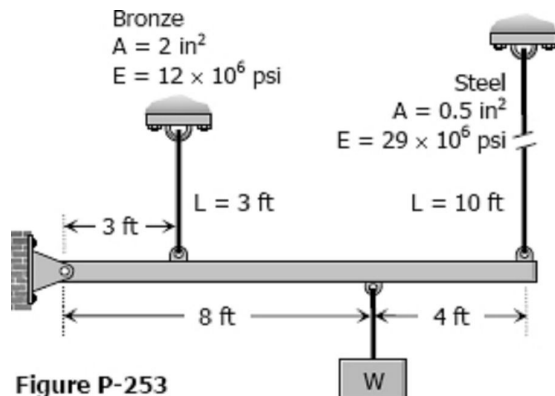

Solution 253

$$\sum M_{pin\ support} = 0$$

$$3P_{br} + 12P_{st} = 8(50\,000)$$

$$3P_{br} + 12P_{st} = 400\,000 \rightarrow \text{Equation (1)}$$

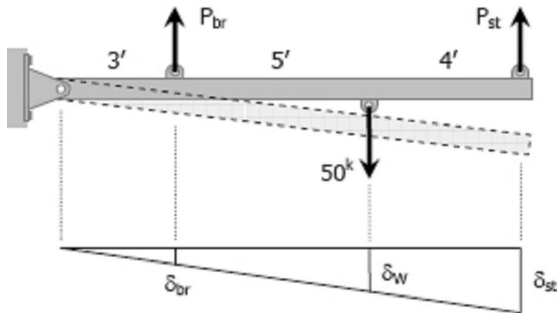

$$\frac{\delta_{st}}{12} = \frac{\delta_{br}}{3}$$

$$\delta_{st} = 4\delta_{br}$$

$$\left(\frac{PL}{AE}\right)_{st} = 4 \left(\frac{PL}{AE}\right)_{br}$$

$$\frac{P_{st}(10)}{0.5(29 \times 10^6)} = 4 \left[\frac{P_{br}(3)}{2(12 \times 10^6)} \right]$$

$$P_{st} = 0.725P_{br}$$

From equation (1)

$$3P_{br} + 12(0.725P_{br}) = 400\,000$$

$$P_{br} = 34\,188.03 \text{ lb}$$

$$\delta_{br} = \left(\frac{PL}{AE}\right)_{br} = \frac{34\,188.03(3 \times 12)}{2(12 \times 10^6)}$$

$$\delta_{br} = 0.0513 \text{ in}$$

$$\frac{\delta_w}{8} = \frac{\delta_{br}}{3}$$

$$\delta_w = \frac{8}{3}\delta_{br}$$

$$\delta_w = \frac{8}{3}(0.0513)$$

$$\delta_w = 0.1368 \text{ in} \rightarrow \text{answer}$$

Check by δ_{st} :

$$P_{st} = 0.725P_{br} = 0.725(34\,188.03)$$

$$P_{st} = 24\,786.32 \text{ lb}$$

$$\delta_{st} = \left(\frac{PL}{AE} \right)_{st} = \frac{24\,786.32(10 \times 12)}{0.5(29 \times 10^6)}$$

$$\delta_{br} = 0.2051 \text{ in}$$

$$\frac{\delta_W}{8} = \frac{\delta_{st}}{12}$$

$$\delta_W = \frac{2}{3}\delta_{st}$$

$$\delta_W = \frac{2}{3}(0.2051)$$

$$\delta_W = 0.1368 \text{ in} \rightarrow \text{ok!}$$

Solution to Problem 254 Statically Indeterminate

As shown in [Fig. P-254](#), a rigid bar with negligible mass is pinned at O and attached to two vertical rods. Assuming that the rods were initially stress-free, what maximum load P can be applied without exceeding stresses of 150 MPa in the steel rod and 70 MPa in the bronze rod.

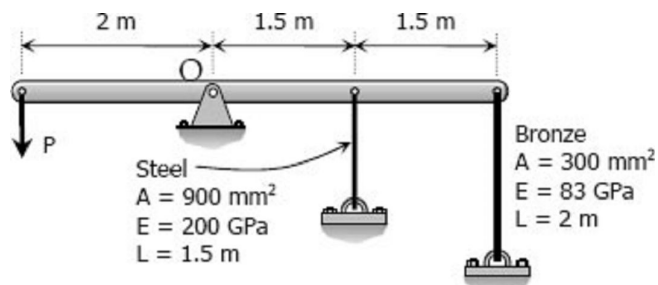

Figure P-254

Solution 254

$$\Sigma M_O = 0$$

$$2P = 1.5P_{st} + 3P_{br}$$

$$2P = 1.5(\sigma_{st} A_{st}) + 3(\sigma_{br} A_{br})$$

$$2P = 1.5[\sigma_{st}(900)] + 3[\sigma_{br}(300)]$$

$$2P = 1350\sigma_{st} + 900\sigma_{br}$$

$$P = 675\sigma_{st} + 450\sigma_{br}$$

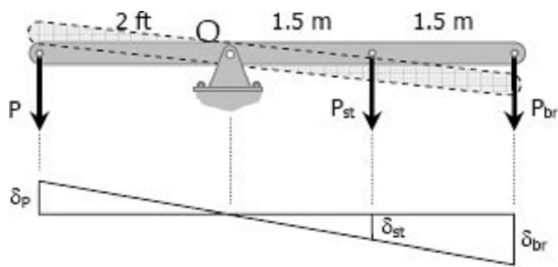

$$\frac{\delta_{br}}{3} = \frac{\delta_{st}}{1.5}$$

$$\delta_{br} = 2\delta_{st}$$

$$\left(\frac{\sigma L}{E}\right)_{br} = 2\left(\frac{\sigma L}{E}\right)_{st}$$

$$\frac{\sigma_{br}(2)}{83} = 2\left[\frac{\sigma_{st}(1.5)}{200}\right]$$

$$\sigma_{br} = 0.6225\sigma_{st}$$

When $\sigma_{st} = 150 \text{ MPa}$

$$\sigma_{br} = 0.6225(150)$$

$$\sigma_{br} = 93.375 \text{ MPa} > 70 \text{ MPa (not ok!)}$$

When $\sigma_{br} = 70 \text{ MPa}$

$$70 = 0.6225\sigma_{st}$$

$$\sigma_{st} = 112.45 \text{ MPa} < 150 \text{ MPa (ok!)}$$

Use $\sigma_{st} = 112.45 \text{ MPa}$ and $\sigma_{br} = 70 \text{ MPa}$

$$P = 675\sigma_{st} + 450\sigma_{br}$$

$$P = 675(112.45) + 450(70)$$

$$P = 107\,403.75 \text{ N}$$

$$P = 107.4 \text{ kN} \rightarrow \text{answer}$$

Solution to Problem 255 Statically Indeterminate

Shown in [Fig. P-255](#) is a section through a balcony. The total uniform load of 600 kN is supported by three rods of the same area and material. Compute the load in each rod. Assume the floor to be rigid, but note that it does not necessarily remain horizontal.

Figure P-255

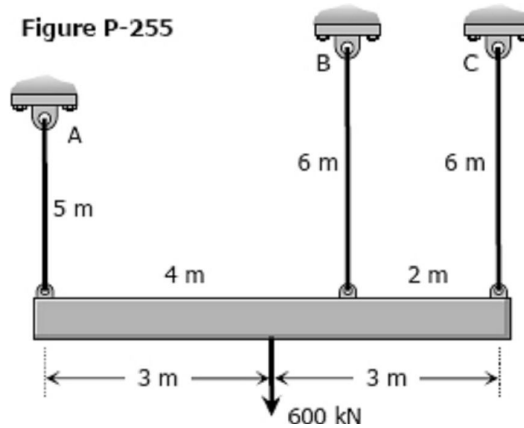

Solution 255

$$\begin{aligned} \delta_B &= \delta_C + \delta_2 \\ \delta_2 &= \delta_B - \delta_C \\ \frac{\delta_1}{6} &= \frac{\delta_2}{2} \\ \delta_1 &= 3\delta_2 \end{aligned}$$

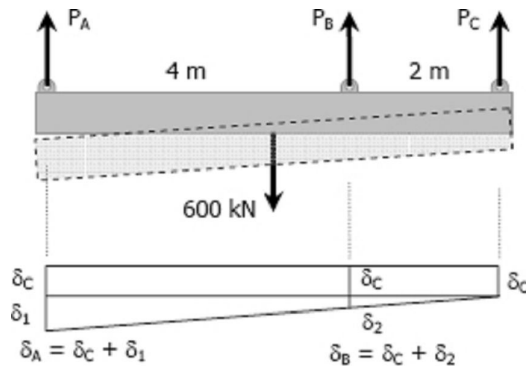

$$\begin{aligned} \delta_A &= \delta_C + \delta_1 \\ \delta_A &= \delta_C + 3\delta_2 \\ \delta_A &= \delta_C + 3(\delta_B - \delta_C) \\ \delta_A &= 3\delta_B - 2\delta_C \\ \left(\frac{PL}{AE}\right)_A &= 3\left(\frac{PL}{AE}\right)_B - 2\left(\frac{PL}{AE}\right)_C \\ \frac{P_A(5)}{AE} &= \frac{3P_B(6)}{AE} - \frac{2P_C(6)}{AE} \\ P_A &= 3.6P_B - 2.4P_C \rightarrow \text{Equation (1)} \end{aligned}$$

$$\begin{aligned} \Sigma F_V &= 0 \\ P_A + P_B + P_C &= 600 \\ (3.6P_B - 2.4P_C) + P_B + P_C &= 600 \\ 4.6P_B - 1.4P_C &= 600 \rightarrow \text{Equation (2)} \end{aligned}$$

$$\begin{aligned} \Sigma M_A &= 0 \\ 4P_B + 6P_C &= 3(600) \end{aligned}$$

$$P_B = 450 - 1.5P_C \rightarrow \text{Equation (3)}$$

Substitute $P_B = 450 - 1.5P_C$ to Equation (2)

$$4.6(450 - 1.5P_C) - 1.4P_C = 600$$

$$8.3P_C = 1470$$

$$P_C = 177.11 \text{ kN} \rightarrow \text{answer}$$

From Equation (3)

$$P_B = 450 - 1.5(177.11)$$

$$P_B = 184.34 \text{ kN} \rightarrow \text{answer}$$

From Equation (1)

$$P_A = 3.6(184.34) - 2.4(177.11)$$

$$P_A = 238.56 \text{ kN} \rightarrow \text{answer}$$

Solution to Problem 256 Statically Indeterminate

Three rods, each of area 250 mm^2 , jointly support a 7.5 kN load, as shown in Fig. P-256. Assuming that there was no slack or stress in the rods before the load was applied, find the stress in each rod. Use $E_{st} = 200 \text{ GPa}$ and $E_{br} = 83 \text{ GPa}$.

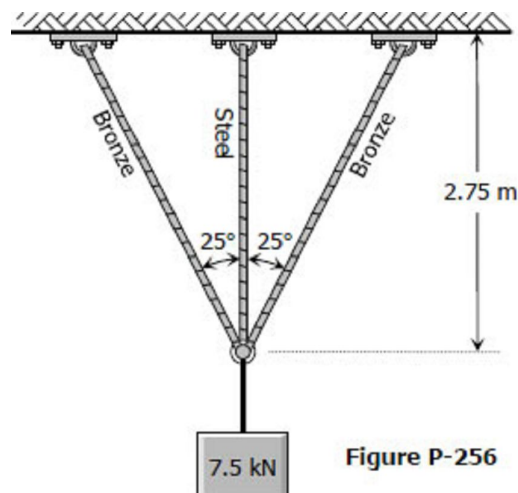
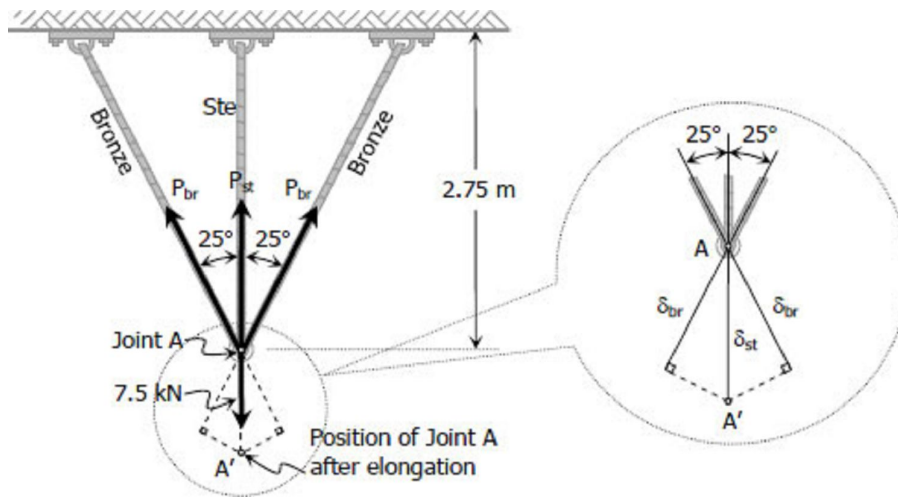

Figure P-256

Solution 256

$$\cos 25^\circ = \frac{2.75}{L_{br}}$$

$$L_{br} = 3.03 \text{ m}$$



$$\Sigma F_V = 0$$

$$2P_{br} \cos 25^\circ + P_{st} = 7.5(1000)$$

$$P_{st} = 7500 - 1.8126P_{br}$$

$$\sigma_{st} A_{st} = 7500 - 1.8126\sigma_{br} A_{br}$$

$$\sigma_{st}(250) = 7500 - 1.8126[\sigma_{br}(250)]$$

$$\sigma_{st} = 30 - 1.8126\sigma_{br} \rightarrow \text{Equation (1)}$$

$$\cos 25^\circ = \frac{\delta_{br}}{\delta_{st}}$$

$$\delta_{br} = 0.9063\delta_{st}$$

$$\left(\frac{\sigma L}{E}\right)_{br} = 0.9063 \left(\frac{\sigma L}{E}\right)_{st}$$

$$\frac{\sigma_{br}(3.03)}{83} = 0.9063 \left[\frac{\sigma_{st}(2.75)}{200}\right]$$

$$\sigma_{br} = 0.3414\sigma_{st} \rightarrow \text{Equation (2)}$$

From Equation (1)

$$\sigma_{st} = 30 - 1.8126(0.3414\sigma_{st})$$

$$\sigma_{st} = 18.53 \text{ MPa} \rightarrow \text{answer}$$

From Equation (2)

$$\sigma_{br} = 0.3414(18.53)$$

$$\sigma_{br} = 6.33 \text{ MPa} \rightarrow \text{answer}$$

Solution to Problem 257 Statically Indeterminate

Three bars AB, AC, and AD are pinned together as shown in [Fig. P-257](#). Initially, the assembly is stress free. Horizontal movement of the joint at A is prevented by a short horizontal strut AE. Calculate the stress in each bar and the force in the strut AE when the assembly is used to support the load $W = 10$ kips. For each steel bar, $A = 0.3 \text{ in.}^2$ and $E = 29 \times 10^6$ psi. For the aluminum bar, $A = 0.6 \text{ in.}^2$ and $E = 10 \times 10^6$ psi.

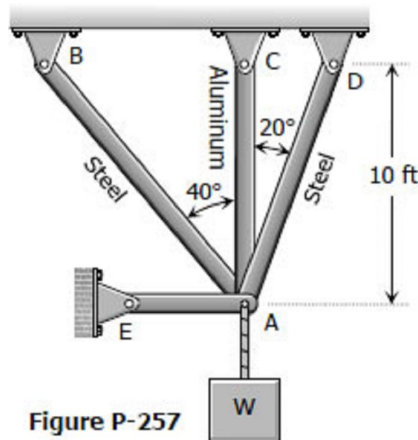

Solution 257

$$\cos 40^\circ = \frac{10}{L_{AB}}; \quad L_{AB} = 13.05 \text{ ft}$$

$$\cos 20^\circ = \frac{10}{L_{AD}}; \quad L_{AD} = 10.64 \text{ ft}$$

$$\sum F_V = 0$$

$$P_{AB} \cos 40^\circ + P_{AC} + P_{AD} \cos 20^\circ = 10(1000)$$

$$0.7660P_{AB} + P_{AC} + 0.9397P_{AD} = 10000 \rightarrow \text{Equation (1)}$$

$$\delta_{AB} = \cos 40^\circ \delta_{AC} = 0.7660 \delta_{AC}$$

$$\left(\frac{PL}{AE} \right)_{AB} = 0.7660 \left(\frac{PL}{AE} \right)_{AC}$$

$$\frac{P_{AB}(13.05)}{0.3(29 \times 10^6)} = 0.7660 \left[\frac{P_{AC}(10)}{0.6(10 \times 10^6)} \right]$$

$$P_{AB} = 0.8511P_{AC} \rightarrow \text{Equation (2)}$$

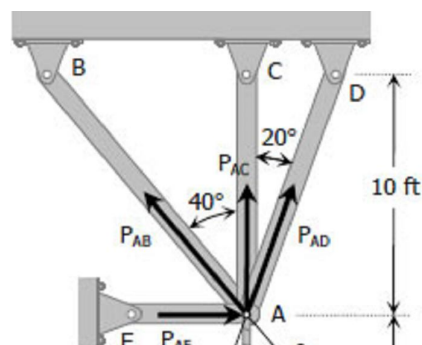

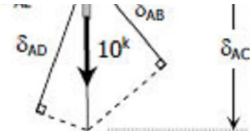

$$\delta_{AD} = \cos 20^\circ \delta_{AC} = 0.9397 \delta_{AC}$$

$$\left(\frac{PL}{AE}\right)_{AD} = 0.9397 \left(\frac{PL}{AE}\right)_{AC}$$

$$\frac{P_{AB}(10.64)}{0.3(29 \times 10^6)} = 0.9397 \left[\frac{P_{AC}(10)}{0.6(10 \times 10^6)} \right]$$

$$P_{AD} = 1.2806 P_{AC} \rightarrow \text{Equation (3)}$$

Substitute P_{AB} of Equation (2) and P_{AD} of Equation (3) to Equation (1)

$$0.7660(0.8511 P_{AC}) + P_{AC} + 0.9397(1.2806 P_{AC}) = 10\,000$$

$$2.8553 P_{AC} = 10\,000$$

$$P_{AC} = 3\,502.23 \text{ textlb}$$

From Equation (2)

$$P_{AB} = 0.8511(3\,502.23)$$

$$P_{AB} = 2\,980.75 \text{ lb}$$

From Equation (3)

$$P_{AD} = 1.2806(3\,502.23)$$

$$P_{AD} = 4\,484.96 \text{ lb}$$

Stresses:

$$\sigma = P/A$$

$$\sigma_{AB} = 2980.75/0.3 = 9\,935.83 \text{ psi} \rightarrow \text{answer}$$

$$\sigma_{AC} = 3502.23/0.6 = 5\,837.05 \text{ psi} \rightarrow \text{answer}$$

$$\sigma_{AD} = 4484.96/0.3 = 14\,949.87 \text{ psi} \rightarrow \text{answer}$$

$$\Sigma F_H = 0$$

$$P_{AE} + P_{AD} \sin 20^\circ = P_{AB} \sin 40^\circ$$

$$P_{AE} = 2\,980.75 \sin 40^\circ - 4\,484.96 \sin 20^\circ$$

$$P_{AE} = 382.04 \text{ lb} \rightarrow \text{answer}$$

Thermal Stress

Temperature changes cause the body to expand or contract. The amount δ_T , is given by

$$\delta_T = \alpha L (T_f - T_i) = \alpha L \Delta T$$

where α is the coefficient of thermal expansion in $\text{m/m}^\circ\text{C}$, L is the length in meter, T_i and T_f are the initial and final temperatures, respectively in $^\circ\text{C}$. For steel, $\alpha = 11.25 \times 10^{-6} \text{ m/m}^\circ\text{C}$.

If temperature deformation is permitted to occur freely, no load or stress will be induced in the structure. In some cases where temperature deformation is not permitted, an internal stress is created. The internal stress created is termed as **thermal stress**.

For a homogeneous rod mounted between unyielding supports as shown, the thermal stress is computed as:



deformation due to temperature changes;

$$\delta_T = \alpha L \Delta T$$

deformation due to equivalent axial stress;

$$\delta_P = \frac{PL}{AE} = \frac{\sigma L}{E}$$

$$\delta_T = \delta_P$$

$$\alpha L \Delta T = \frac{\sigma L}{E}$$

$$\sigma = E \alpha \Delta T$$

where σ is the thermal stress in MPa, E is the modulus of elasticity of the rod in MPa.

If the wall yields a distance of x as shown, the following calculations will be made:

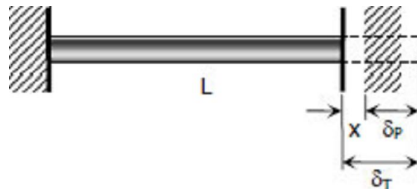

$$\delta_T = x + \delta_P$$

$$\alpha L \Delta T = x + \frac{\sigma L}{E}$$

where σ represents the thermal stress.

Take note that as the temperature rises above the normal, the rod will be in compression, and if the temperature drops below the normal, the rod is in tension.

Solution to Problem 261 Thermal Stress

A steel rod with a cross-sectional area of 0.25 in^2 is stretched between two fixed points. The tensile load at 70°F is 1200 lb. What will be the stress at 0°F ? At what temperature will the stress be zero? Assume $\alpha = 6.5 \times 10^{-6} \text{ in}/(\text{in}\cdot^\circ\text{F})$ and $E = 29 \times 10^6 \text{ psi}$.

Solution 261

For the stress at 0°C :

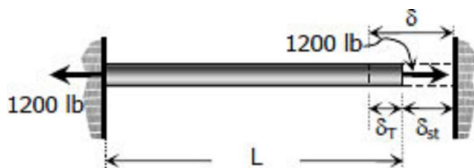

$$\delta = \delta_T + \delta_{st}$$

$$\frac{\sigma L}{E} = \alpha L (\Delta T) + \frac{PL}{AE}$$

$$\sigma = \alpha E (\Delta T) + \frac{P}{A}$$

$$\sigma = (6.5 \times 10^{-6})(29 \times 10^6)(70) + \frac{1200}{0.25}$$

$$\sigma = 17995 \text{ psi} = 18 \text{ ksi} \rightarrow \text{answer}$$

For the temperature that causes zero stress:

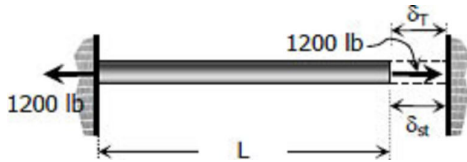

$$\delta_T = \delta_{st}$$

$$\alpha L(\Delta T) = \frac{PL}{AE}$$

$$\alpha(\Delta T) = \frac{P}{AE}$$

$$(6.5 \times 10^{-6})(T-70) = \frac{1200}{0.25(29 \times 10^6)}$$

$$T = 95.46^\circ\text{C} \rightarrow \text{answer}$$

Solution to Problem 262 Thermal Stress

A steel rod is stretched between two rigid walls and carries a tensile load of 5000 N at 20°C. If the allowable stress is not to exceed 130 MPa at -20°C, what is the minimum diameter of the rod? Assume $\alpha = 11.7 \mu\text{m}/(\text{m}\cdot^\circ\text{C})$ and $E = 200 \text{ GPa}$.

Solution 262

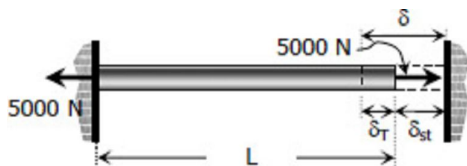

$$\delta = \delta_T + \delta_{st}$$

$$\frac{\sigma L}{E} = \alpha L(\Delta T) + \frac{PL}{AE}$$

$$\sigma = \alpha E(\Delta T) + \frac{P}{A}$$

$$130 = (11.7 \times 10^{-6})(200\,000)(40) + \frac{5000}{A}$$

$$A = \frac{5000}{36.4} = 137.36 \text{ mm}^2$$

$$\frac{1}{4}\pi d^2 = 137.36$$

$$d = 13.22 \text{ mm} \rightarrow \text{answer}$$

Solution to Problem 263 Thermal Stress

Steel railroad rails 10 m long are laid with a clearance of 3 mm at a temperature of 15°C. At what temperature will the rails just touch? What stress would be induced in the rails at that temperature if there were no initial clearance? Assume $\alpha = 11.7 \mu\text{m}/(\text{m}\cdot^\circ\text{C})$ and $E = 200 \text{ GPa}$.

Solution 263

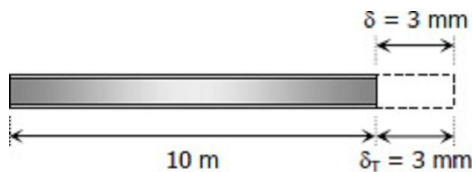

Temperature at which $\delta_T = 3 \text{ mm}$:

$$\delta_T = \alpha L (\Delta T)$$

$$\delta_T = \alpha L (T_f - T_i)$$

$$3 = (11.7 \times 10^{-6})(10\,000)(T_f - 15)$$

$$T_f = 40.64^\circ\text{C} \rightarrow \text{answer}$$

Required stress:

$$\delta = \delta_T$$

$$\frac{\sigma L}{E} = \alpha L (\Delta T)$$

$$\sigma = \alpha E (T_f - T_i)$$

$$\sigma = (11.7 \times 10^{-6})(200\,000)(40.64 - 15)$$

$$\sigma = 60 \text{ MPa} \rightarrow \text{answer}$$

Solution to Problem 264 Thermal Stress

Problem 264

A steel rod 3 feet long with a cross-sectional area of 0.25 in.^2 is stretched between two fixed points. The tensile force is 1200 lb at 40°F . Using $E = 29 \times 10^6 \text{ psi}$ and $\alpha = 6.5 \times 10^{-6} \text{ in.}/(\text{in.}\cdot^\circ\text{F})$, calculate (a) the temperature at which the stress in the bar will be 10 ksi; and (b) the temperature at which the stress will be zero.

Solution 264

(a) Without temperature change:

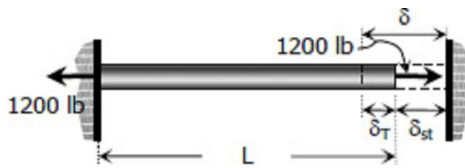

$$\sigma = \frac{P}{A} = \frac{1200}{0.25} = 4800 \text{ psi}$$

$$\sigma = 4.8 \text{ ksi} < 10 \text{ ksi}$$

A drop of temperature is needed to increase the stress to 10 ksi. See figure above.

$$\delta = \delta_T + \delta_{st}$$

$$\frac{\sigma L}{E} = \alpha L (\Delta T) + \frac{PL}{AE}$$

$$\sigma = \alpha E (\Delta T) + \frac{P}{A}$$

$$10\,000 = (6.5 \times 10^{-6})(29 \times 10^6)(\Delta T) + \frac{1200}{0.25}$$

$$\Delta T = 27.59^\circ\text{F}$$

Required temperature: (*temperature must drop from 40°F*)

$$T = 40 - 27.59 = 12.41^\circ\text{F} \rightarrow \text{answer}$$

(b) From the figure below:

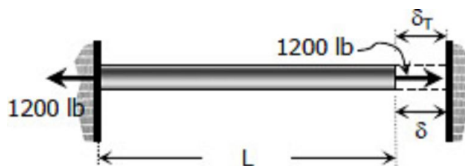

$$\delta = \delta_T$$

$$\frac{PL}{AE} = \alpha L(\Delta T)$$

$$P = \alpha AE(T_f - T_i)$$

$$1200 = (6.5 \times 10^{-6})(0.25)(29 \times 10^6)(T_f - 40)$$

$$T_f = 65.46^\circ\text{F} \rightarrow \text{answer}$$

Solution to Problem 265 Thermal Stress

A bronze bar 3 m long with a cross sectional area of 320 mm^2 is placed between two rigid walls as shown in Fig. P-265. At a temperature of -20°C , the gap $\Delta = 25 \text{ mm}$. Find the temperature at which the compressive stress in the bar will be 35 MPa. Use $\alpha = 18.0 \times 10^{-6} \text{ m}/(\text{m}\cdot^\circ\text{C})$ and $E = 80 \text{ GPa}$.

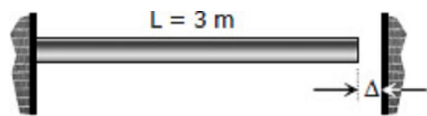
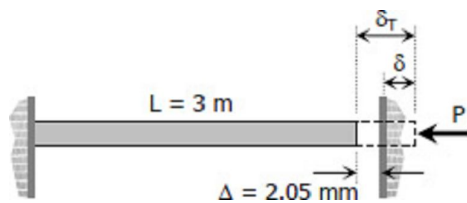

Figure P-265

Problem 265

$$\delta_T = \delta + \Delta$$



$$\alpha L(\Delta T) = \frac{\sigma L}{E} + 2.5$$

$$(18 \times 10^{-6})(3000)(\Delta T) = \frac{35(3000)}{80000} + 2.5$$

$$\Delta T = 70.6^\circ\text{C}$$

$$T = 70.6 - 20$$

$$T = 50.6^\circ\text{C} \rightarrow \text{answer}$$

Solution to Problem 266 Thermal Stress

Calculate the increase in stress for each segment of the compound bar shown in Fig. P-266 if the temperature increases by 100°F. Assume that the supports are unyielding and that the bar is suitably braced against buckling.

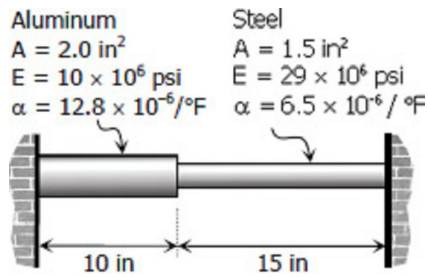
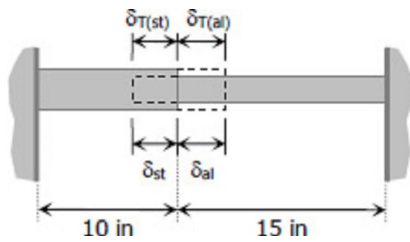

Figure P-266

Problem 266

$$\delta_T = \alpha L \Delta T$$



$$\delta_{T(st)} = (6.5 \times 10^{-6})(15)(100)$$

$$\delta_{T(st)} = 0.00975$$

$$\delta_{T(al)} = (12.8 \times 10^{-6})(10)(100)$$

$$\delta_{T(al)} = 0.0128 \text{ in}$$

$$\delta_{st} + \delta_{al} = \delta_{T(st)} + \delta_{T(al)}$$

$$\left(\frac{PL}{AE}\right)_{st} + \left(\frac{PL}{AE}\right)_{al} = 0.00975 + 0.0128$$

where $P = P_{st} = P_{al}$

$$\frac{P(15)}{1.5(29 \times 10^6)} + \frac{P(10)}{2(10 \times 10^6)} = 0.02255$$

$$P = 26691.84 \text{ psi}$$

$$\sigma = \frac{P}{A}$$

$$\sigma_{st} = \frac{26691.84}{1.5} = 17794.56 \text{ psi} \rightarrow \text{answer}$$

$$\sigma_{al} = \frac{26691.84}{2.0} = 13345.92 \text{ psi} \rightarrow \text{answer}$$

Solution to Problem 267 Thermal Stress

At a temperature of 80°C, a steel tire 12 mm thick and 90 mm wide that is to be shrunk onto a locomotive driving wheel 2 m in diameter just fits over the wheel, which is at a temperature of 25°C. Determine the contact pressure between the tire and wheel after the assembly cools to 25°C. Neglect the deformation of the wheel caused by the pressure of the tire. Assume $\alpha = 11.7 \mu\text{m}/(\text{m}\cdot^\circ\text{C})$ and $E = 200 \text{ GPa}$.

Solution 267

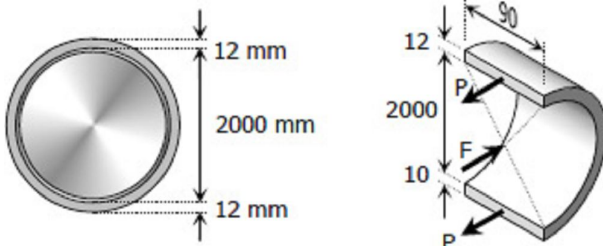

$$\delta = \delta_T$$

$$\frac{PL}{AE} = \alpha L \Delta T$$

$$P = \alpha \Delta T AE$$

$$P = (11.7 \times 10^{-6})(80-25)(90 \times 12)(200000)$$

$$P = 138\,996\text{ N}$$

$$F = 2P$$

$$pDL = 2P$$

$$p(2000)(90) = 2(138\,996)$$

$$p = 1.5444\text{ MPa} \rightarrow \text{answer}$$

Solution to Problem 268 Thermal Stress

The rigid bar ABC in Fig. P-268 is pinned at B and attached to the two vertical rods. Initially, the bar is horizontal and the vertical rods are stress-free. Determine the stress in the aluminum rod if the temperature of the steel rod is decreased by 40°C . Neglect the weight of bar ABC.

Figure P-268

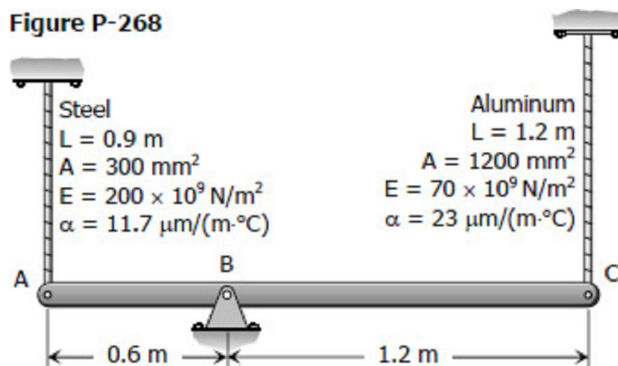

Solution 268

Contraction of steel rod, assuming complete freedom:

$$\delta_{T(st)} = \alpha L \Delta T$$

$$\delta_{T(st)} = (11.7 \times 10^{-6})(900)(40)$$

$$\delta_{T(st)} = 0.4212\text{ mm}$$

The steel rod cannot freely contract because of the resistance of aluminum rod. The movement of A (referred to as δ_A), therefore, is less than 0.4212 mm. In terms of aluminum, this movement is (by ratio and proportion):

$$\frac{\delta_A}{0.6} = \delta_{al} 1.2$$

$$\delta_A = 0.5\delta_{al}$$

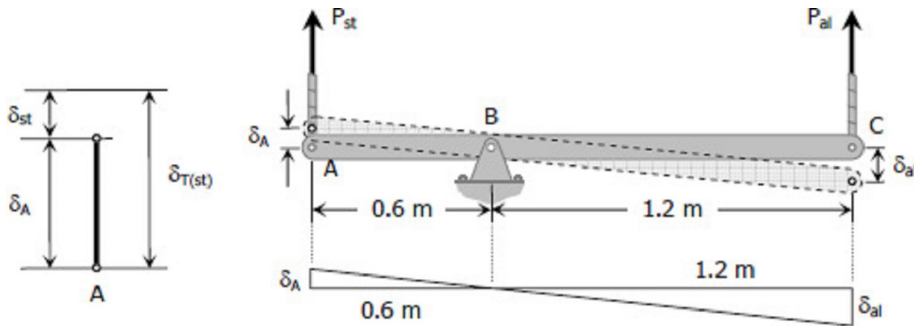

$$\delta_{T(st)} - \delta_{st} = 0.5\delta_{al}$$

$$0.4212 - \left(\frac{PL}{AE}\right)_{st} = 0.5 \left(\frac{PL}{AE}\right)_{al}$$

$$0.4212 - \frac{P_{st}(900)}{300(200\,000)} = 0.5 \left[\frac{P_{al}(1200)}{1\,200(70\,000)} \right]$$

$$28080 - P_{st} = 0.4762P_{al} \rightarrow \text{Equation (1)}$$

$$\Sigma M_B = 0$$

$$0.6P_{st} = 1.2P_{al}$$

$$P_{st} = 2P_{al} \rightarrow \text{Equation (2)}$$

Equations (1) and (2)

$$28\,080 - 2P_{al} = 0.4762P_{al}$$

$$P_{al} = 11\,340 \text{ N}$$

$$\sigma_{al} = \frac{P_{al}}{A_{al}} = \frac{11\,340}{1200}$$

$$\sigma_{al} = 9.45 \text{ MPa} \rightarrow \text{answer}$$

Solution to Problem 269 Thermal Stress

Problem 269

As shown in Fig. P-269, there is a gap between the aluminum bar and the rigid slab that is supported by two copper bars. At 10°C, $\Delta = 0.18$ mm. Neglecting the mass of the slab, calculate the stress in each rod when the temperature in the assembly is increased to 95°C. For each copper bar, $A = 500 \text{ mm}^2$, $E = 120 \text{ GPa}$, and $\alpha = 16.8 \text{ } \mu\text{m}/(\text{m}\cdot^\circ\text{C})$. For the aluminum bar, $A = 400 \text{ mm}^2$, $E = 70 \text{ GPa}$, and $\alpha = 23.1 \text{ } \mu\text{m}/(\text{m}\cdot^\circ\text{C})$.

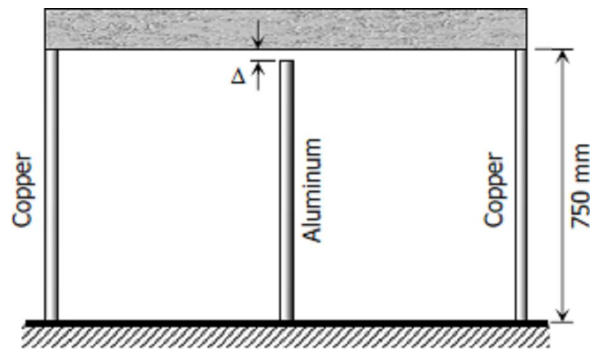

Figure P-269

Solution 269

Assuming complete freedom:

$$\delta_T = \alpha L \Delta T$$

$$\delta_{T(co)} = (16.8 \times 10^{-6})(750)(95-10)$$

$$\delta_{T(co)} = 1.071 \text{ mm}$$

$$\delta_{T(al)} = (23.1 \times 10^{-6})(750-0.18)(95-10)$$

$$\delta_{T(al)} = 1.472 \text{ mm}$$

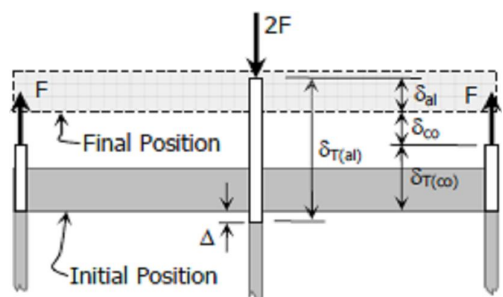

From the figure:

$$\delta_{T(al)} - \delta_{al} = \delta_{T(co)} + \delta_{co}$$

$$1.472 - \left(\frac{PL}{AE} \right)_{al} = 1.071 + \left(\frac{PL}{AE} \right)_{co}$$

$$1.472 - \frac{2F(750-0.18)}{400(70\,000)} = 1.071 + \frac{F(750)}{500(120\,000)}$$

$$0.401 = (6.606 \times 10^{-5}) F$$

$$F = 6070.37 \text{ N}$$

$$P_{co} = F = 6070.37 \text{ N}$$

$$P_{al} = 2F = 12\,140.74 \text{ N}$$

$$\sigma = P/A$$

$$\sigma_{co} = \frac{6070.37}{500} = 12.14 \text{ MPa} \rightarrow \text{answer}$$

$$\sigma_{al} = \frac{12\,140.74}{400} = 30.35 \text{ MPa} \rightarrow \text{answer}$$

Solution to Problem 270 Thermal Stress

A bronze sleeve is slipped over a steel bolt and held in place by a nut that is turned to produce an initial stress of 2000 psi in the bronze. For the steel bolt, $A = 0.75 \text{ in}^2$, $E = 29 \times 10^6 \text{ psi}$, and $\alpha = 6.5 \times 10^{-6} \text{ in}/(\text{in}\cdot^\circ\text{F})$. For the bronze sleeve, $A = 1.5 \text{ in}^2$, $E = 12 \times 10^6 \text{ psi}$ and $\alpha = 10.5 \times 10^{-6} \text{ in}/(\text{in}\cdot^\circ\text{F})$. After a temperature rise of 100°F , find the final stress in each material.

Solution 270

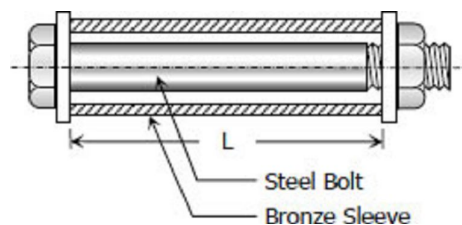

Before temperature change:

$$P_{br} = \sigma_{br} A_{br}$$

$$P_{br} = 2000(1.5)$$

$$P_{br} = 3000 \text{ lb compression}$$

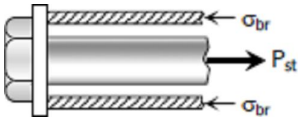

$$\Sigma F_H = 0$$

$$P_{st} = P_{br} = 3000 \text{ lb tension}$$

$$\sigma_{st} = P_{st}/A_{st} = 3000/0.75$$

$$\sigma_{st} = 4000 \text{ psi tensile stress}$$

$$\delta = \frac{\sigma L}{E}$$

$$a = \delta_{br} = \frac{2000L}{12 \times 10^6} = 1.67 \times 10^{-4}L \text{ shortening}$$

$$b = \delta_{st} = \frac{4000L}{29 \times 10^6} = 1.38 \times 10^{-4}L \text{ lengthening}$$

With temperature rise of 100°F: (Assuming complete freedom)

$$\delta_T = \alpha L \Delta T$$

$$\delta_{Tbr} = (10.5 \times 10^{-6})L (100)$$

$$\delta_{Tbr} = 1.05 \times 10^{-3}L > a$$

$$\delta_{Tst} = (6.5 \times 10^{-6})L (100)$$

$$\delta_{Tst} = 6.5 \times 10^{-4}L$$

$$\delta_{Tbr} - a = 1.05 \times 10^{-3}L - 1.67 \times 10^{-4}L$$

$$\delta_{Tbr} - a = 8.83 \times 10^{-4}L$$

$$\delta_{Tst} + b = 6.5 \times 10^{-4}L + 1.38 \times 10^{-4}L$$

$$\delta_{Tst} + b = 7.88 \times 10^{-4}L$$

$$\delta_{Tbr} - a > \delta_{Tst} + b \text{ (see figure below)}$$

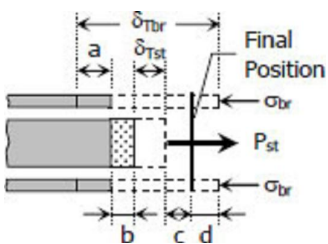

$$\delta_{Tbr}-a-d = b + \delta_{Tst} + c$$

$$(1.05 \times 10^{-3}L) - (1.67 \times 10^{-4}L) - \left(\frac{\sigma L}{E}\right)_{br} = (1.38 \times 10^{-4}L) + (6.5 \times 10^{-4}L) + \left(\frac{P}{A}\right)$$

$$(8.83 \times 10^{-4}L) - \frac{\sigma_{br}L}{12 \times 10^6} = (7.88 \times 10^{-4}L) + \frac{P_{st}L}{0.75(29 \times 10^6)}$$

$$9.5 \times 10^{-4} - \frac{P_{br}}{1.5(12 \times 10^6)} = \frac{P_{st}}{0.75(29 \times 10^6)}$$

$$P_{st} = 20\,662.5 - 1.2083P_{br} \rightarrow \text{Equation (1)}$$

$$\Sigma F_H = 0$$

$$P_{br} = P_{st} \rightarrow \text{Equation (2)}$$

Equations (1) and (2)

$$P_{st} = 20\,662.5 - 1.2083P_{st}$$

$$P_{st} = 9356.74 \text{ lb}$$

$$P_{br} = 9356.74 \text{ lb}$$

$$\sigma = P/A$$

$$\sigma_{br} = \frac{9356.74}{1.5} = 6237.83 \text{ psi compressive stress } \textit{answer}$$

$$\sigma_{st} = \frac{9356.74}{0.75} = 12475.66 \text{ psi tensile stress } \textit{answer}$$

Solution to Problem 271 Thermal Stress

A rigid bar of negligible weight is supported as shown in Fig. P-271. If $W = 80 \text{ kN}$, compute the temperature change that will cause the stress in the steel rod to be 55 MPa . Assume the coefficients of linear expansion are $11.7 \mu\text{m}/(\text{m}\cdot^\circ\text{C})$ for steel and $18.9 \mu\text{m}/(\text{m}\cdot^\circ\text{C})$ for bronze.

Figure P-271 and P-272

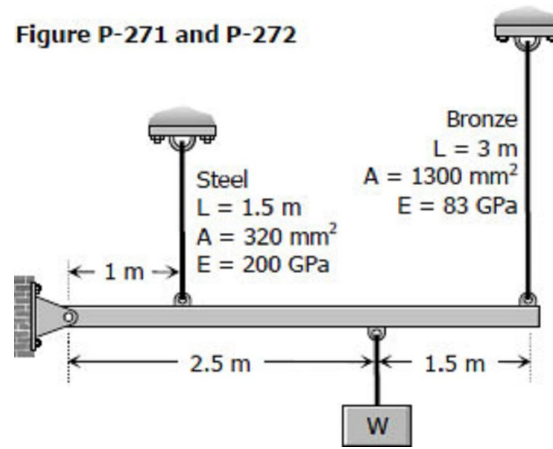

Solution 271

Stress in bronze when $\sigma_{st} = 55 \text{ MPa}$

$$\sum M_A = 0$$

$$4P_{br} + P_{st} = 2.5(80\,000)$$

$$4\sigma_{br}(1300) + 55(320) = 2.5(80\,000)$$

$$\sigma_{br} = 35.08 \text{ MPa}$$

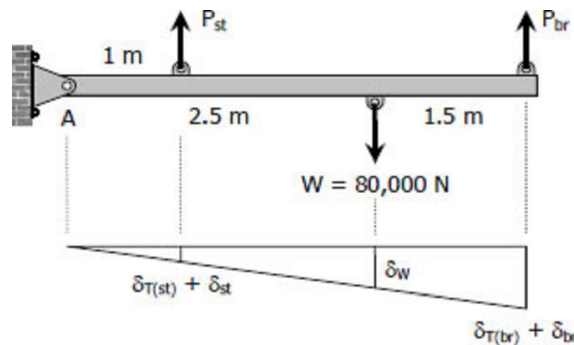

By ratio and proportion:

$$\frac{\delta_{T(st)} + \delta_{st}}{1} = \frac{\delta_{T(br)} + \delta_{br}}{4}$$

$$\delta_{T(st)} + \delta_{st} = 0.25 [\delta_{T(br)} + \delta_{br}]$$

$$(\alpha L \Delta T)_{st} + \left(\frac{\sigma L}{E}\right)_{st} = 0.25 \left[(\alpha L \Delta T)_{br} + \left(\frac{\sigma L}{E}\right)_{br} \right]$$

$$(11.7 \times 10^{-6})(1500)\Delta T + \frac{55(1500)}{2000} = 0.25 \left[(18.9 \times 10^{-6})(3000)\Delta T + \frac{35.08(3000)}{83\,000} \right]$$

$$0.01755\Delta T + 0.4125 = 0.014175\Delta T + 0.317$$

$$\Delta T = -28.3^\circ\text{C}$$

A temperature drop of **28.3°C** is needed to stress the steel to 55 MPa. *answer*

Solution to Problem 272 Thermal Stress

For the assembly in [Fig. 271](#), find the stress in each rod if the temperature rises 30°C after a load $W = 120$ kN is applied.

Solution 272

$$\sum M_A = 0$$

$$4P_{br} + P_{st} = 2.5(80\,000)$$

$$4\sigma_{br}(1300) + \sigma_{st}(320) = 2.5(80\,000)$$

$$16.25\sigma_{br} + \sigma_{st} = 625$$

$$\sigma_{st} = 625 - 16.25\sigma_{br} \rightarrow \text{Equation (1)}$$

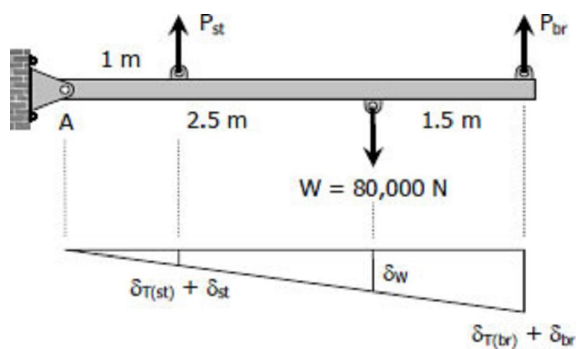
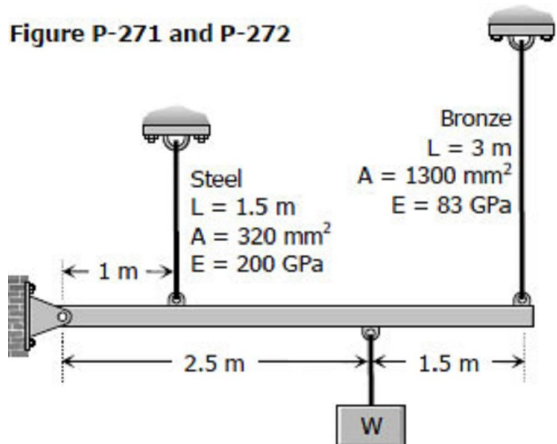

$$\frac{\delta_{T(st)} + \delta_{st}}{1} = \frac{\delta_{T(br)} + \delta_{br}}{4}$$

$$\delta_{T(st)} + \delta_{st} = 0.25 [\delta_{T(br)} + \delta_{br}]$$

$$(\alpha L \Delta T)_{st} + \left(\frac{\sigma L}{E} \right)_{st} = 0.25 \left[(\alpha L \Delta T)_{br} + \left(\frac{\sigma L}{E} \right)_{br} \right]$$

$$(11.7 \times 10^{-6})(1500)(30) + \frac{\sigma_{st}(1500)}{200\,000} = 0.25 \left[(18.9 \times 10^{-6})(3000)(30) + \frac{\sigma_{br}(3000)}{83\,000} \right]$$

$$0.5265 + 0.0075\sigma_{st} = 0.42525 + 0.00904\sigma_{br}$$

$$0.0075\sigma_{st} - 0.00904\sigma_{br} = -0.10125$$

$$0.0075(625 - 16.25\sigma_{br}) - 0.00904\sigma_{br} = -0.10125$$

$$4.6875 - 0.121875\sigma_{br} - 0.00904\sigma_{br} = -0.10125$$

$$4.78875 = 0.130915\sigma_{br}$$

$$\sigma_{br} = 36.58^\circ\text{C} \text{ answer}$$

$$\sigma_{st} = 625 - 16.25(36.58)$$

$$\sigma_{st} = 30.58 \text{ deg; C answer}$$

Solution to Problem 273 Thermal Stress

The composite bar shown in [Fig. P-273](#) is firmly attached to unyielding supports. An axial force $P = 50$ kips is applied at 60°F . Compute the stress in each material at 120°F . Assume $\alpha = 6.5 \times 10^{-6} \text{ in}/(\text{in}\cdot^\circ\text{F})$ for steel and $12.8 \times 10^{-6} \text{ in}/(\text{in}\cdot^\circ\text{F})$ for aluminum.

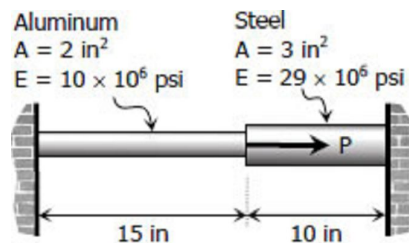

Figure P-273 and P-274

Solution 273

$$\delta_{T(al)} = (\alpha L \Delta T)_{al}$$

$$\delta_{T(al)} = (12.8 \times 10^{-6})(15)(120-60)$$

$$\delta_{T(al)} = 0.01152 \text{ inch}$$

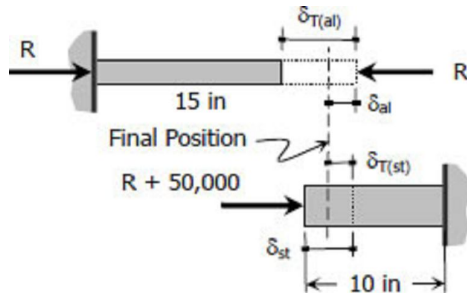

$$\delta_{T(st)} = (\alpha L \Delta T)_{st}$$

$$\delta_{T(st)} = (6.5 \times 10^{-6})(10)(120-60)$$

$$\delta_{T(st)} = 0.0039 \text{ inch}$$

$$\delta_{T(al)} - \delta_{al} = \delta_{st} - \delta_{T(st)}$$

$$0.01152 - \left(\frac{PL}{AE}\right)_{al} = \left(\frac{PL}{AE}\right)_{st} - 0.0039$$

$$100224 - 6.525R = R + 50000 - 33930$$

$$84154 = 7.525R$$

$$R = 11183.25 \text{ lbs}$$

$$P_{al} = R = 11183.25 \text{ lbs}$$

$$P_{st} = R + 50000 = 61183.25 \text{ lbs}$$

$$\sigma = \frac{P}{A}$$

$$\sigma_{al} = \frac{11183.25}{2} = 5591.62 \text{ psi answer}$$

$$\sigma_{st} = \frac{61183.25}{3} = 20394.42 \text{ psi answer}$$

Solution to Problem 274 Thermal Stress

At what temperature will the aluminum and steel segments in [Prob. 273](#) have numerically equal stress?

Solution 274

$$\sigma_{al} = \sigma_{st}$$

$$\frac{R_1}{2} = \frac{(50\,000 - R_1)}{3}$$

$$3R_1 = 100\,000 - 2R_1$$

$$R_1 = 20\,000 \text{ lbs}$$

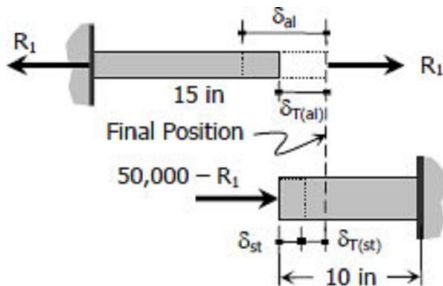

$$\delta = \frac{PL}{AE}$$

$$\delta_{al} = \frac{20\,000(15)}{2(10 \times 10^6)} = 0.015 \text{ inch}$$

$$\delta_{st} = \frac{(50\,000 - 20\,000)(10)}{3(29 \times 10^6)} = 0.00345 \text{ inch}$$

$$\delta_{al} - \delta_{T(al)} = \delta_{st} + \delta_{T(st)}$$

$$0.015 - (12.8 \times 10^{-6})(15) \Delta T = 0.00345 + (6.5 \times 10^{-6})(10) \Delta T$$

$$0.01155 = 0.000257 \Delta T$$

$$\Delta T = 44.94^\circ F$$

A drop of **44.94°F** from the standard temperature will make the aluminum and steel segments equal in stress. *answer*

Solution to Problem 275 Thermal Stress

A rigid horizontal bar of negligible mass is connected to two rods as shown in Fig. P-275. If the system is initially stress-free. Calculate the temperature change that will cause a tensile stress of 90 MPa in the brass rod. Assume that both rods are subjected to the change in temperature.

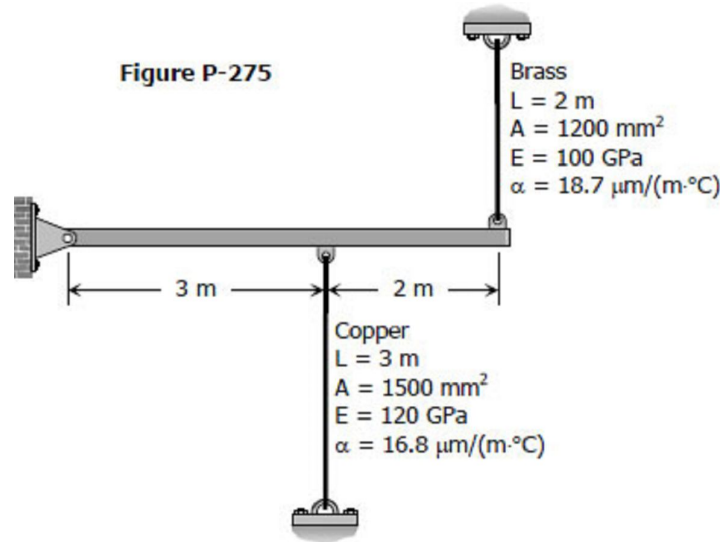

Solution 275

$$\Sigma M_{\text{hinge support}} = 0$$

$$5P_{br} - 3P_{co} = 0$$

$$5\sigma_{br} A_{br} - 3\sigma_{co} A_{co} = 0$$

$$5(90)(1200) - 3\sigma_{co}(1500) = 0$$

$$\sigma_{co} = 120 \text{ MPa}$$

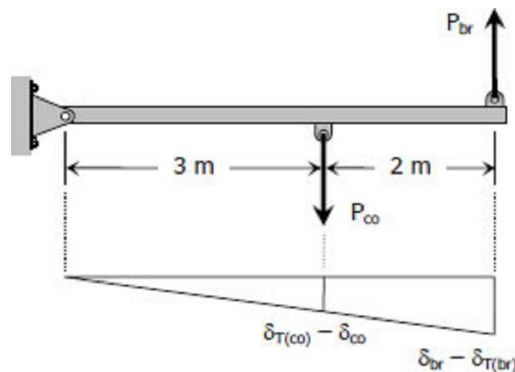

$$\delta = \frac{\sigma L}{E}$$

$$\delta_{br} = \frac{90(2000)}{100\,000} = 1.8 \text{ mm}$$

$$\delta_{co} = \frac{120(3000)}{120\,000} = 3 \text{ mm}$$

$$\frac{\delta_{T(co)} - \delta_{co}}{3} = \frac{\delta_{br} - \delta_{T(br)}}{5}$$

$$5\delta_{T(co)} - 5\delta_{co} = 3\delta_{br} - 3\delta_{T(br)}$$

$$5(16.8 \times 10^{-6})(3000) \Delta T - 5(3) = 3(1.8) - 3(18.7 \times 10^{-6})(2000) \Delta T$$

$$0.3642 \Delta T = 20.4$$

$$\Delta T = 56.01^\circ\text{C} \text{ drop in temperature } \textit{answer}$$

Solution to Problem 276 Thermal Stress

Four steel bars jointly support a mass of 15 Mg as shown in [Fig. P-276](#). Each bar has a cross-sectional area of 600 mm^2 . Find the load carried by each bar after a temperature rise of 50°C . Assume $\alpha = 11.7 \mu\text{m}/(\text{m}\cdot^\circ\text{C})$ and $E = 200 \text{ GPa}$.

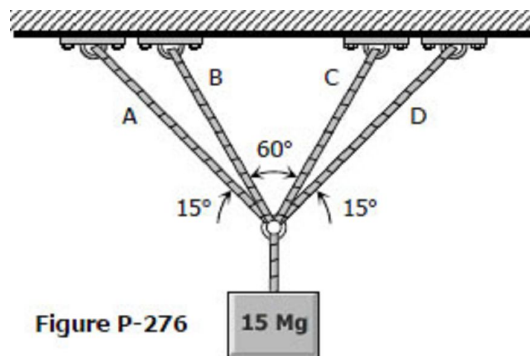
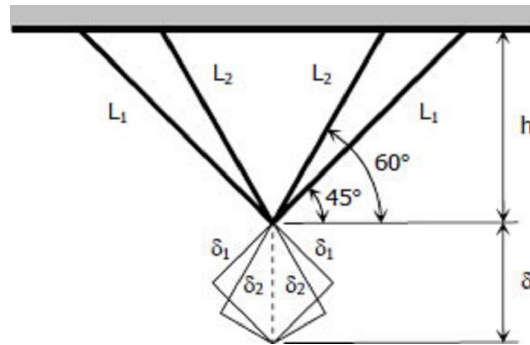

Figure P-276

Solution 276

$$h = L_1 \sin 45^\circ$$

$$h = L_2 \sin 60^\circ$$



$$h = h$$

$$L_1 \sin 45^\circ = L_2 \sin 60^\circ$$

$$L_1 = 1.2247L_2$$

$$\delta_1 = \delta \sin 45^\circ$$

$$\delta_2 = \delta \sin 60^\circ$$

$$\frac{\delta_1}{\delta_2} = \frac{\delta \sin 45^\circ}{\delta \sin 60^\circ}$$

$$\delta_1 = 0.8165\delta_2$$

$$\alpha L_1 \Delta T + \frac{P_1 L_1}{AE} = 0.8165 \left[\alpha L_2 \Delta T + \frac{P_2 L_2}{AE} \right]$$

$$(11.7 \times 10^{-6})L_1(50) + \frac{P_1 L_1}{600(200\,000)} = 0.8165 \left[(11.7 \times 10^{-6})(50) + \frac{P_2 L_2}{600(200\,000)} \right]$$

$$70,200L_1 + P_1 L_1 = 0.8165(70,200L_2 + P_2 L_2)$$

$$(70,200 + P_1)L_1 = 0.8165(70,200 + P_2)L_2$$

$$(70,200 + P_1)1.2247L_2 = 0.8165(70,200 + P_2)L_2$$

$$1.5(70,200 + P_1) = 70,200 + P_2$$

$$P_2 = 1.5P_1 + 35,100 \rightarrow \text{Equation (1)}$$

$$\Sigma F_V = 0$$

$$2(P_1 \sin 45^\circ) + 2(P_2 \sin 60^\circ) = 147.15(1000)$$

$$P_1 \sin 45^\circ + P_2 \sin 60^\circ = 72,575$$

$$P_1 \sin 45^\circ + (1.5P_1 + 35,100) \sin 60^\circ = 72,575$$

$$0.7071P_1 + 1.299P_1 + 30,397.49 = 72,575$$

$$2.0061P_1 = 42,177.51$$

$$P_1 = 21,024.63 \text{ N}$$

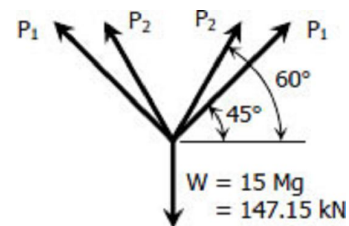

$$P_2 = 1.5(21,024.63) + 35,100$$

$$P_2 = 66,636.94 \text{ N}$$

$$P_A = P_D = P_1 = 21.02 \text{ kN } \textit{answer}$$

$$P_B = P_C = P_2 = 66.64 \text{ kN } \textit{answer}$$

Chapter 3 - Torsion

Torsion

1. Torsion
2. Flanged Bolt Couplings
3. Torsion of Thin-Walled Tubes
4. Helical Springs

Torsion

TORSION

Consider a bar to be rigidly attached at one end and twisted at the other end by a torque or twisting moment T equivalent to $F \times d$, which is applied perpendicular to the axis of the bar, as shown in the figure. Such a bar is said to be in torsion.

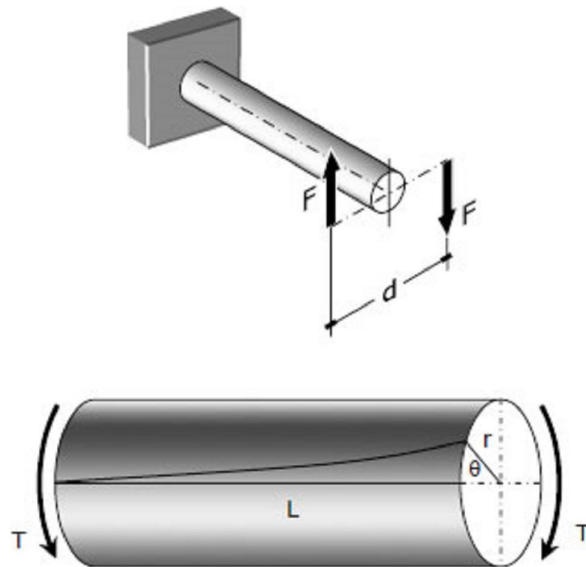

TORSIONAL SHEARING STRESS, τ

For a solid or hollow circular shaft subject to a twisting moment T , the torsional shearing stress τ at a

distance ρ from the center of the shaft is

$$\tau = \frac{T\rho}{J} \quad \text{and} \quad \tau_{max} = \frac{Tr}{J}$$

where J is the polar moment of inertia of the section and r is the outer radius.

For solid cylindrical shaft:

$$J = \frac{\pi}{32} D^4$$
$$\tau_{max} = \frac{16T}{\pi D^3}$$

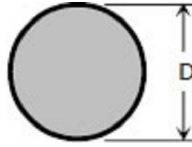

For hollow cylindrical shaft:

$$J = \frac{\pi}{32} (D^4 - d^4)$$
$$\tau_{max} = \frac{16TD}{\pi(D^4 - d^4)}$$

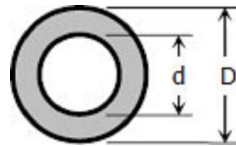

ANGLE OF TWIST

The angle θ through which the bar length L will twist is

$$\theta = \frac{TL}{JG} \quad \text{in radians}$$

where T is the torque in N·mm, L is the length of shaft in mm, G is shear modulus in MPa, J is the polar moment of inertia in mm^4 , D and d are diameter in mm, and r is the radius in mm.

POWER TRANSMITTED BY THE SHAFT

A shaft rotating with a constant angular velocity ω (in radians per second) is being acted by a twisting moment T . The power transmitted by the shaft is

$$P = T\omega = 2\pi Tf$$

where T is the torque in N·m, f is the number of revolutions per second, and P is the power in watts.

Solution to Problem 304 Torsion

A steel shaft 3 ft long that has a diameter of 4 in is subjected to a torque of 15 kip-ft. Determine the maximum shearing stress and the angle of twist. Use $G = 12 \times 10^6$ psi.

Solution 304

$$\tau_{max} = \frac{16T}{\pi D^3} = \frac{16(15)(1000)(12)}{\pi(4^3)}$$

$$\tau_{max} = 14324 \text{ psi}$$

$$\tau_{max} = 14.3 \text{ ksi } \textit{answer}$$

$$\theta = \frac{TL}{JG} = \frac{15(3)(1000)(12^2)}{\frac{1}{32}\pi(4^4)(12 \times 10^6)}$$

$$\theta = 0.0215 \text{ rad}$$

$$\theta = 1.23^\circ \textit{ answer}$$

Solution to Problem 305 Torsion

What is the minimum diameter of a solid steel shaft that will not twist through more than 3° in a 6-m length when subjected to a torque of 12 kN·m? What maximum shearing stress is developed? Use $G = 83$ GPa.

Solution 305

$$\theta = \frac{TL}{JG}$$

$$3^\circ \left(\frac{\pi}{180^\circ} \right) = \frac{12(6)(1000^3)}{\frac{1}{32}\pi d^4(83\,000)}$$

$$d = 113.98 \text{ mm } \textit{answer}$$

$$\tau_{max} = \frac{16T}{\pi d^3} = \frac{16(12)(1000^2)}{\pi(113.98^3)}$$

$$\tau_{max} = 41.27 \text{ MPa } \textit{answer}$$

Solution to Problem 306 Torsion

Problem 306

A steel marine propeller shaft 14 in. in diameter and 18 ft long is used to transmit 5000 hp at 189 rpm. If $G = 12 \times 10^6$ psi, determine the maximum shearing stress.

Solution 306

$$T = \frac{P}{2\pi f} = \frac{5000(396\,000)}{2\pi(189)}$$

$$T = 1\,667\,337.5 \text{ lb} \cdot \text{in}$$

$$\tau_{max} = \frac{16T}{\pi d^3} = \frac{16(1\,667\,337.5)}{\pi(14^3)}$$

$$\tau_{max} = 3094.6 \text{ psi } \textit{answer}$$

Solution to Problem 307 Torsion

A solid steel shaft 5 m long is stressed at 80 MPa when twisted through 4° . Using $G = 83$ GPa, compute the shaft diameter. What power can be transmitted by the shaft at 20 Hz?

Solution 307

$$\theta = \frac{TL}{JG}$$

$$4^\circ \left(\frac{\pi}{180^\circ} \right) = \frac{T(5)(1000)}{\frac{1}{32}\pi d^4(83\,000)}$$

$$T = 0.1138d^4$$

$$\tau_{max} = \frac{16T}{\pi d^3}$$

$$80 = \frac{16(0.1138d^4)}{\pi d^3}$$

$$d = 138 \text{ mm } \textit{answer}$$

$$T = \frac{P}{2\pi f}$$

$$0.1138d^4 = \frac{P}{2\pi(20)}$$

$$P = 14.3d^4 = 14.3(1384)$$

$$P = 5\,186\,237\,285 \text{ N} \cdot \text{mm}/\text{sec}$$

$$P = 5\,186\,237.28 \text{ W}$$

$$P = 5.19 \text{ MW } \textit{answer}$$

Solution to Problem 308 Torsion

A 2-in-diameter steel shaft rotates at 240 rpm. If the shearing stress is limited to 12 ksi, determine the maximum horsepower that can be transmitted.

Solution 308

$$\tau_{max} = \frac{16T}{\pi d^3}$$

$$12(1000) = \frac{16T}{\pi(2^3)}$$

$$T = 18\,849.56 \text{ lb} \cdot \text{in}$$

$$T = \frac{P}{2\pi f}$$

$$18\,849.56 = \frac{P(396\,000)}{2\pi(240)}$$

$$P = 71.78 \text{ hp } \textit{answer}$$

Solution to Problem 309 Torsion

Problem 309

A steel propeller shaft is to transmit 4.5 MW at 3 Hz without exceeding a shearing stress of 50 MPa or twisting through more than 1° in a length of 26 diameters. Compute the proper diameter if $G = 83$

GPa.

Solution 309

$$T = \frac{P}{2\pi f} = \frac{4.5(1\,000\,000)}{2\pi(3)}$$

$$T = 238\,732.41 \text{ N} \cdot \text{m}$$

Based on maximum allowable shearing stress:

$$\tau_{max} = \frac{16T}{\pi d^3}$$

$$50 = \frac{16(238\,732.41)(1000)}{\pi d^3}$$

$$d = 289.71 \text{ mm}$$

Based on maximum allowable angle of twist:

$$\theta = \frac{TL}{JG}$$

$$1^\circ \left(\frac{\pi}{180^\circ} \right) = \frac{238\,732.41(26d)(1000)}{\frac{1}{32}\pi d^4(83\,000)}$$

$$d = 352.08 \text{ mm}$$

Use the bigger diameter, **d = 352 mm answer**

Solution to Problem 310 Torsion

Show that the hollow circular shaft whose inner diameter is half the outer diameter has a torsional strength equal to 15/16 of that of a solid shaft of the same outside diameter.

Solution 310

Hollow circular shaft:

$$\tau_{max-hollow} = \frac{16TD}{\pi(D^4 - d^4)}$$



$$\tau_{max-hollow} = \frac{16TD}{\pi [D^4 - (\frac{1}{2}D)^4]}$$

$$\tau_{max-hollow} = \frac{16TD}{\pi(\frac{15}{16}D^4)}$$

$$\tau_{max-hollow} = \frac{16^2 T}{15\pi D^3}$$



Solid circular shaft:

$$\tau_{max-solid} = \frac{16T}{\pi D^3}$$

$$\tau_{max-solid} = \frac{15}{16} \left[\frac{16^2 T}{15\pi D^3} \right]$$

$$\tau_{max-solid} = \frac{15}{16} \times \tau_{max-hollow} \text{ ok!}$$

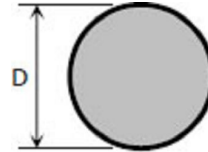

Solution to Problem 311 Torsion

An aluminum shaft with a constant diameter of 50 mm is loaded by torques applied to gears attached to it as shown in [Fig. P-311](#). Using $G = 28 \text{ GPa}$, determine the relative angle of twist of gear D relative to gear A.

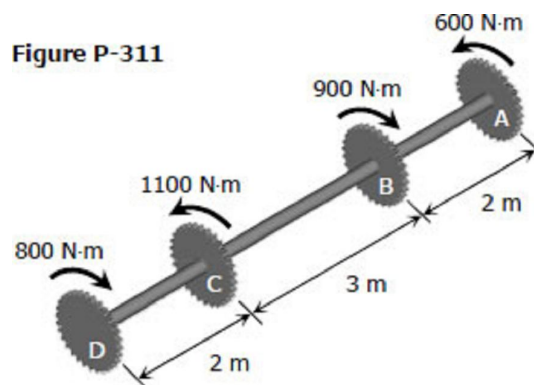

Problem 311

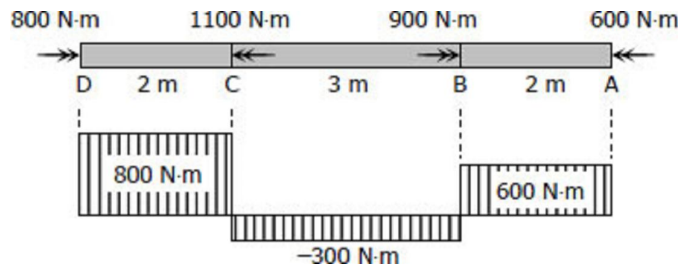

$$\theta = \frac{TL}{JG}$$

Rotation of D relative to A:

$$\theta_{D/A} = \frac{1}{JG} \sum TL$$

$$\theta_{D/A} = \frac{1}{\frac{1}{32}\pi(50^4)(28\,000)} [800(2) - 300(3) + 600(2)] (1000^2)$$

$$\theta_{D/A} = 0.1106 \text{ rad}$$

$$\theta_{D/A} = 6.34^\circ \text{ answer}$$

Solution to Problem 312 Torsion

A flexible shaft consists of a 0.20-in-diameter steel wire encased in a stationary tube that fits closely enough to impose a frictional torque of 0.50 lb · in/in. Determine the maximum length of the shaft if the shearing stress is not to exceed 20 ksi. What will be the angular deformation of one end relative to the other end? $G = 12 \times 10^6$ psi.

Solution 312

$$\tau_{max} = \frac{16T}{\pi d^3}$$

$$20(1000) = \frac{16T}{\pi(0.20)^3}$$

$$T = 10\pi \text{ lb} \cdot \text{in}$$

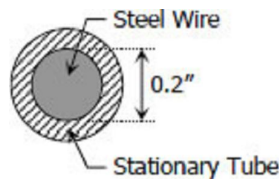

$$L = \frac{T}{0.50 \text{ lb} \cdot \text{in/in}}$$

$$L = \frac{10\pi \text{ lb} \cdot \text{in}}{0.50 \text{ lb} \cdot \text{in}/\text{in}}$$

$$L = 20\pi \text{ in} = 62.83 \text{ in}$$

$$\theta = \frac{TL}{JG}$$

If $\theta = d\theta$, $T = 0.5L$ and $L = dL$

$$\int d\theta = \frac{1}{JG} \int_0^{20\pi} (0.5L) dL$$

$$\theta = \left[\frac{0.5L^2}{2} \right]_0^{20\pi} = \frac{1}{JG} [0.25(20\pi)^2 - 0.25(0)^2]$$

$$\theta = \frac{100\pi^2}{\frac{1}{32}\pi(0.20^4)(12 \times 10^6)}$$

$$\theta = 0.5234 \text{ rad} = 30^\circ \text{ answer}$$

Solution to Problem 313 Torsion

Determine the maximum torque that can be applied to a hollow circular steel shaft of 100-mm outside diameter and an 80-mm inside diameter without exceeding a shearing stress of 60 MPa or a twist of 0.5 deg/m. Use $G = 83 \text{ GPa}$.

Solution 313

Based on maximum allowable shearing stress:

$$\tau_{max} = \frac{16TD}{\pi(D^4 - d^4)}$$

$$60 = \frac{16T(100)}{\pi(100^4 - 80^4)}$$

$$T = 6955486.14 \text{ N} \cdot \text{mm}$$

$$T = 6955.5 \text{ N} \cdot \text{m}$$

Based on maximum allowable angle of twist:

$$\theta = \frac{TL}{JG}$$

$$0.5^\circ \left(\frac{\pi}{180^\circ} \right) = \frac{T(1000)}{\frac{1}{32}\pi(100^4 - 80^4)(83\,000)}$$

$$T = 4\,198\,282.97 \text{ N} \cdot \text{mm}$$

$$T = 4\,198.28 \text{ N} \cdot \text{m}$$

Use the smaller torque, $T = 4\,198.28 \text{ N} \cdot \text{m}$ answer

Solution to Problem 314 Torsion

The steel shaft shown in [Fig. P-314](#) rotates at 4 Hz with 35 kW taken off at A, 20 kW removed at B, and 55 kW applied at C. Using $G = 83 \text{ GPa}$, find the maximum shearing stress and the angle of rotation of gear A relative to gear C.

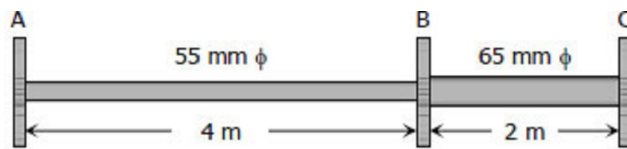

Figure P-314

Solution 314

$$T = \frac{P}{2\pi f}$$

$$T_A = \frac{-35(1000)}{2\pi(4)} = -1392.6 \text{ N} \cdot \text{m}$$

$$T_B = \frac{-20(1000)}{2\pi(4)} = -795.8 \text{ N} \cdot \text{m}$$

$$T_C = \frac{55(1000)}{2\pi(4)} = 2188.4 \text{ N} \cdot \text{m}$$

Relative to C:

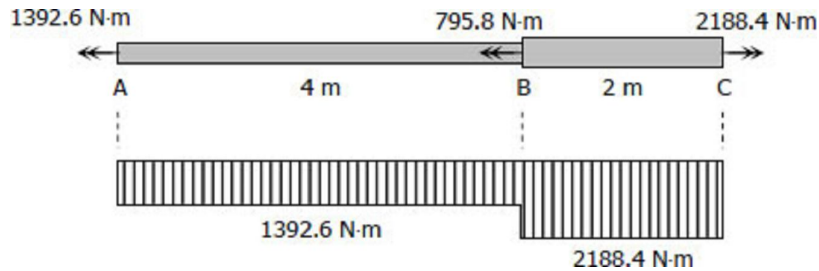

$$\tau_{max} = \frac{16T}{\pi d^3}$$

$$\tau_{AB} = \frac{16(1392.6)(1000)}{\pi(55^3)} = 42.63 \text{ MPa}$$

$$\tau_{BC} = \frac{16(2188.4)(1000)}{\pi(65^3)} = 40.58 \text{ MPa}$$

$$\therefore \tau_{max} = \tau_{AB} = 42.63 \text{ MPa } \textit{answer}$$

$$\theta = \frac{TL}{JG}$$

$$\theta_{A/C} = \frac{1}{G} \sum \frac{TL}{J}$$

$$\theta_{A/C} = \frac{1}{83\,000} \left[\frac{1392.6(4)}{\frac{1}{32}\pi(55^4)} + \frac{2188.4(2)}{\frac{1}{32}\pi(65^4)} \right] (1000^2)$$

$$\theta_{A/C} = 0.104\,796\,585 \text{ rad}$$

$$\theta_{A/C} = 6.004^\circ \textit{ answer}$$

Solution to Problem 315 Torsion

A 5-m steel shaft rotating at 2 Hz has 70 kW applied at a gear that is 2 m from the left end where 20 kW are removed. At the right end, 30 kW are removed and another 20 kW leaves the shaft at 1.5 m from the right end. (a) Find the uniform shaft diameter so that the shearing stress will not exceed 60 MPa. (b) If a uniform shaft diameter of 100 mm is specified, determine the angle by which one end of the shaft lags behind the other end. Use $G = 83 \text{ GPa}$.

Solution 315

$$T = \frac{P}{2\pi f}$$

$$T_A = T_C = \frac{-20(1000)}{2\pi(2)} = -1591.55 \text{ N} \cdot \text{m}$$

$$T_B = \frac{70(1000)}{2\pi(2)} = 5570.42 \text{ N} \cdot \text{m}$$

$$T_D = \frac{-30(1000)}{2\pi(2)} = -2387.32 \text{ N} \cdot \text{m}$$

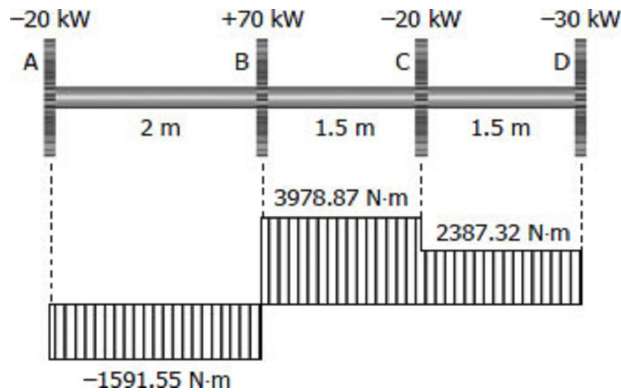

Part (a)

$$\tau_{max} = \frac{16T}{\pi d^3}$$

For AB $60 = \frac{16(1591.55)(1000)}{\pi d^3}$

$$d = 51.3 \text{ mm}$$

For BC $60 = \frac{16(3978.87)(1000)}{\pi d^3}$

$$d = 69.6 \text{ mm}$$

For CD $60 = \frac{16(2387.32)(1000)}{\pi d^3}$

$$d = 58.7 \text{ mm}$$

Use $d = 69.6 \text{ mm}$ *answer*

Part (b)

$$\theta = \frac{TL}{JG}$$

$$\theta_{D/A} = \frac{1}{JG} \sum TL$$

$$\theta_{D/A} = \frac{1}{\frac{1}{32}\pi(100^4)(83\,000)} [-1591.55(2) + 3978.87(1.5) + 2387.32(1.5)] (1000^2)$$

$$\theta_{D/A} = 0.007\,813 \text{ rad}$$

$$\theta_{D/A} = 0.448^\circ \text{ answer}$$

Solution to Problem 316 Torsion

A compound shaft consisting of a steel segment and an aluminum segment is acted upon by two torques as shown in Fig. P-316. Determine the maximum permissible value of T subject to the following conditions: $\tau_{st} \leq 83 \text{ MPa}$, $\tau_{al} \leq 55 \text{ MPa}$, and the angle of rotation of the free end is limited to 6° . For steel, $G = 83 \text{ GPa}$ and for aluminum, $G = 28 \text{ GPa}$.

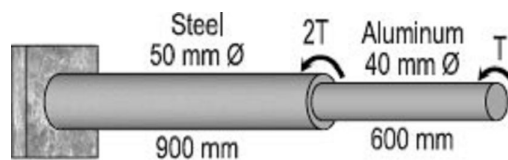
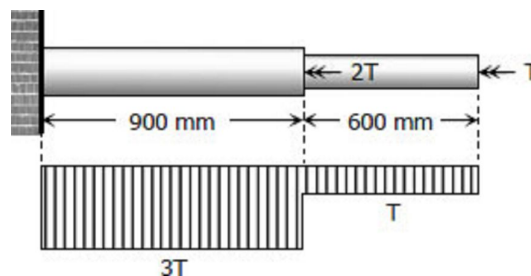

Figure P-316

Solution 316



Based on maximum shearing stress $\tau_{\max} = 16T / \pi d^3$:

Steel

$$\tau_{st} = \frac{16(3T)}{\pi(50^3)} = 83$$

$$T = 679\,042.16 \text{ N} \cdot \text{mm}$$

$$T = 679.04 \text{ N} \cdot \text{m}$$

Aluminum

$$\tau_{al} = \frac{16T}{\pi(40^3)} = 55$$

$$T = 691\,150.38 \text{ N} \cdot \text{mm}$$

$$T = 691.15 \text{ N} \cdot \text{m}$$

Based on maximum angle of twist:

$$\theta = \left(\frac{TL}{JG} \right)_{st} + \left(\frac{TL}{JG} \right)_{al}$$

$$6^\circ \left(\frac{\pi}{180^\circ} \right) = \frac{3T(900)}{\frac{1}{32}\pi(50^4)(83\,000)} + \frac{T(600)}{\frac{1}{32}\pi(40^4)(28\,000)}$$

$$T = 757\,316.32 \text{ N} \cdot \text{mm}$$

$$T = 757.32 \text{ N} \cdot \text{m}$$

Use $T = 679.04 \text{ N} \cdot \text{m}$ *answer*

Solution to Problem 317 Torsion

A hollow bronze shaft of 3 in. outer diameter and 2 in. inner diameter is slipped over a solid steel shaft 2 in. in diameter and of the same length as the hollow shaft. The two shafts are then fastened rigidly together at their ends. For bronze, $G = 6 \times 10^6$ psi, and for steel, $G = 12 \times 10^6$ psi. What torque can be applied to the composite shaft without exceeding a shearing stress of 8000 psi in the bronze or 12 ksi in the steel?

Solution 317

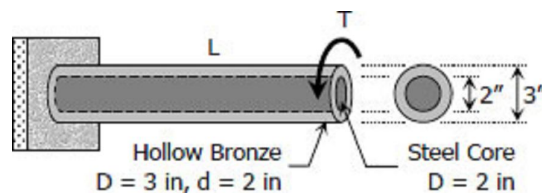

$$\theta_{st} = \theta_{br}$$

$$\left(\frac{TL}{JG}\right)_{st} = \left(\frac{TL}{JG}\right)_{br}$$

$$\frac{T_{st}L}{\frac{1}{32}\pi(2^4)(12 \times 10^6)} = \frac{T_{br}L}{\frac{1}{32}\pi(3^4 - 2^4)(6 \times 10^6)}$$

$$\frac{T_{st}}{192 \times 10^6} = \frac{T_{br}}{390 \times 10^6} \rightarrow \text{Equation (1)}$$

Applied Torque = Resisting Torque

$$T = T_{st} + T_{br} \rightarrow \text{Equation (2)}$$

Equation (1) with T_{st} in terms of T_{br} and Equation (2)

$$T = \frac{192 \times 10^6}{390 \times 10^6} T_{br} + T_{br}$$

$$T_{br} = 0.6701T$$

Equation (1) with T_{br} in terms of T_{st} and Equation (2)

$$T = T_{st} + \frac{390 \times 10^6}{192 \times 10^6} T_{st}$$

$$T_{st} = 0.3299T$$

Based on hollow bronze ($T_{br} = 0.6701T$)

$$\tau_{max} = \left[\frac{16TD}{\pi(D^4 - d^4)} \right]_{br}$$

$$8000 = \frac{16(0.6701T)(3)}{\pi(3^4 - 2^4)}$$

$$T = 50789.32 \text{ lb} \cdot \text{in}$$

$$T = 4232.44 \text{ lb} \cdot \text{ft}$$

Based on steel core ($T_{st} = 0.3299T$):

$$\tau_{max} = \left[\frac{16TD}{\pi D^3} \right]_{st}$$

$$12\,000 = \frac{16(0.3299T)}{\pi(2^3)}$$

$$T = 57\,137.18 \text{ lb} \cdot \text{in}$$

$$T = 4761.43 \text{ lb} \cdot \text{ft}$$

Use $T = 4232.44 \text{ lb} \cdot \text{ft}$ *answer*

Solution to Problem 318 Torsion

A solid aluminum shaft 2 in. in diameter is subjected to two torques as shown in [Fig. P-318](#). Determine the maximum shearing stress in each segment and the angle of rotation of the free end. Use $G = 4 \times 10^6 \text{ psi}$.

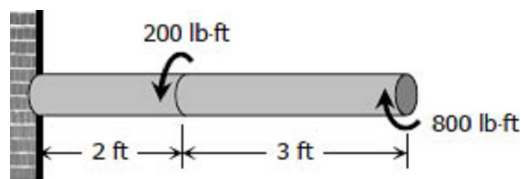
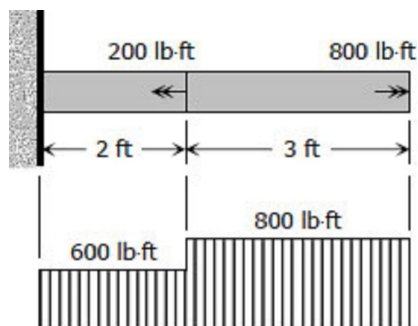

Figure P-318

Solution 318



$$\tau_{max} = \frac{16T}{\pi D^3}$$

For 2-ft segment:

$$\tau_{max2} = \frac{16(600)(12)}{\pi(2^3)} = 4583.66 \text{ psi } \textit{answer}$$

For 3-ft segment:

$$\tau_{max3} = \frac{16(800)(12)}{\pi(2^3)} = 6111.55 \text{ psi } \textit{answer}$$

$$\theta = \frac{TL}{JG}$$

$$\theta = \frac{1}{JG} \Sigma TL$$

$$\theta = \frac{1}{\frac{1}{32}\pi(2^4)(4 \times 10^6)} [600(2) + 800(3)] (12^2)$$

$$\theta = 0.0825 \text{ rad}$$

$$\theta = 4.73^\circ \textit{ answer}$$

Solution to Problem 319 Torsion

The compound shaft shown in [Fig. P-319](#) is attached to rigid supports. For the bronze segment AB, the diameter is 75 mm, $\tau \leq 60$ MPa, and $G = 35$ GPa. For the steel segment BC, the diameter is 50 mm, $\tau \leq 80$ MPa, and $G = 83$ GPa. If $a = 2$ m and $b = 1.5$ m, compute the maximum torque T that can be applied.

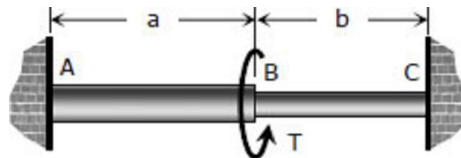
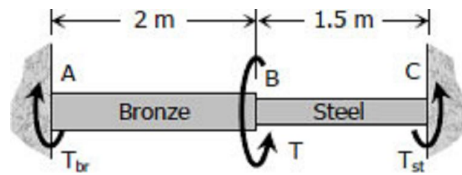

Figure P-319 and P-320

Solution 319



$$\Sigma M = 0$$

$$T = T_{br} + T_{st} \rightarrow \text{Equation (1)}$$

$$\theta_{br} = \theta_{st}$$

$$\left(\frac{TL}{JG}\right)_{br} = \left(\frac{TL}{JG}\right)_{st}$$

$$\frac{T_{br}(2)(1000)}{\frac{1}{32}\pi(75^4)(35\,000)} = \frac{T_{st}(1.5)(1000)}{\frac{1}{32}\pi(50^4)(83\,000)}$$

$$T_{br} = 1.6011T_{st} \rightarrow \text{Equation (2a)}$$

$$T_{st} = 0.6246T_{br} \rightarrow \text{Equation (2b)}$$

$$\tau_{max} = \frac{16T}{\pi D^3}$$

Based on $\tau_{br} \leq 60 \text{ MPa}$

$$60 = \frac{16T_{br}}{\pi(75^3)}$$

$$T_{br} = 4\,970\,097.75 \text{ N} \cdot \text{mm}$$

$$T_{br} = 4.970 \text{ kN} \cdot \text{m} \rightarrow \text{Maximum allowable torque for bronze}$$

$$T_{st} = 0.6246(4.970) \rightarrow \text{From Equation (2b)}$$

$$T_{st} = 3.104 \text{ kN} \cdot \text{m}$$

Based on $\tau_{st} \leq 80 \text{ MPa}$

$$80 = \frac{16T_{st}}{\pi(50^3)}$$

$$T_{st} = 1\,963\,495.41 \text{ N} \cdot \text{mm}$$

$$T_{st} = 1.963 \text{ kN} \cdot \text{m} \rightarrow \text{Maximum allowable torque for steel}$$

$$T_{br} = 1.6011(1.963) \rightarrow \text{From Equation (2a)}$$

$$T_{br} = 3.142 \text{ kN} \cdot \text{m}$$

Use $T_{br} = 3.142 \text{ kN} \cdot \text{m}$ and $T_{st} = 1.963 \text{ kN} \cdot \text{m}$

$$T = 3.142 + 1.963 \rightarrow \text{From Equation (1)}$$

$$T = 5.105 \text{ kN} \cdot \text{m} \text{ answer}$$

Solution to Problem 320 Torsion

In [Prob. 319](#), determine the ratio of lengths b/a so that each material will be stressed to its permissible limit. What torque T is required?

Solution 320

From [Solution 319](#):

Maximum $T_{br} = 4.970 \text{ kN} \cdot \text{m}$

Maximum $T_{st} = 1.963 \text{ kN} \cdot \text{m}$

$$\begin{aligned} \theta_{br} &= \theta_{st} \\ \left(\frac{TL}{JG} \right)_{br} &= \left(\frac{TL}{JG} \right)_{st} \\ \frac{4.973a(1000^2)}{\frac{1}{32}\pi(75^4)(35\,000)} &= \frac{1.963b(1000^2)}{\frac{1}{32}\pi(50^4)(83\,000)} \\ b/a &= 1.187 \end{aligned}$$

$$T = T_{br \text{ max}} + T_{st \text{ max}}$$

$$T = 4.970 + 1.963$$

$$T = 6.933 \text{ kN} \cdot \text{m} \text{ answer}$$

Solution to Problem 321 Torsion

Problem 321

A torque T is applied, as shown in [Fig. P-321](#), to a solid shaft with built-in ends. Prove that the resisting torques at the walls are $T_1 = Tb/L$ and $T_2 = Ta/L$. How would these values be changed if the shaft were hollow?

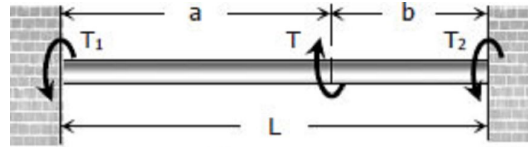

Figure P-321

Solution 321

$$\Sigma M = 0$$

$$T = T_1 + T_2 \rightarrow \text{Equation (1)}$$

$$\theta_1 = \theta_2$$

$$\left(\frac{TL}{JG}\right)_1 = \left(\frac{TL}{JG}\right)_2$$

$$\frac{T_1 a}{JG} = \frac{T_2 b}{JG}$$

$$T_1 = \frac{b}{a} T_2 \rightarrow \text{Equation (2a)}$$

$$T_2 = \frac{a}{b} T_1 \rightarrow \text{Equation (2b)}$$

Equations (1) and (2b):

$$T = T_1 + \frac{a}{b} T_1$$

$$T = \frac{T_1 b + T_1 a}{b}$$

$$T = \frac{(b + a)T_1}{b}$$

$$T = \frac{LT_1}{b}$$

$$T_1 = Tb/L \text{ ok!}$$

Equations (1) and (2a):

$$T = \frac{b}{a} T_2 + T_2$$

$$T = \frac{T_2 b + T_2 a}{a}$$

$$T = \frac{(b + a) T_2}{a}$$

$$T = \frac{L T_2}{a}$$

$$T_2 = T a / L \text{ ok!}$$

If the shaft were hollow, Equation (1) would be the same and the equality $\theta_1 = \theta_2$, by direct investigation, would yield the same result in Equations (2a) and (2b). Therefore, the values of T_1 and T_2 are the same (no change) if the shaft were hollow.

Solution to Problem 322 Torsion

A solid steel shaft is loaded as shown in [Fig. P-322](#). Using $G = 83 \text{ GPa}$, determine the required diameter of the shaft if the shearing stress is limited to 60 MPa and the angle of rotation at the free end is not to exceed 4 deg .

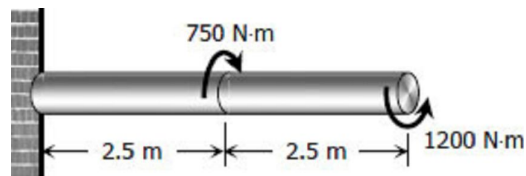
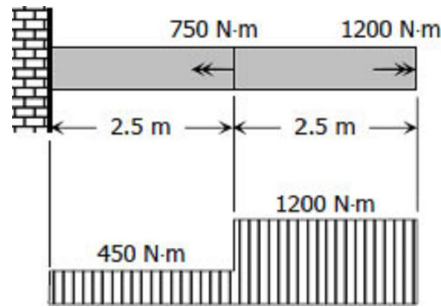

Figure P-322

Solution 322

Based on maximum allowable shear:

$$\tau_{max} = \frac{16T}{\pi D^3}$$



For the 1st segment:

$$60 = \frac{450(2.5)(1000^2)}{\pi D^3}$$

$$D = 181.39 \text{ mm}$$

For the 2nd segment:

$$60 = \frac{1200(2.5)(1000^2)}{\pi D^3}$$

$$D = 251.54 \text{ mm}$$

Based on maximum angle of twist:

$$\theta = \frac{TL}{JG}$$

$$\theta = \frac{1}{JG} \sum TL$$

$$4^\circ \left(\frac{\pi}{180^\circ} \right) = \frac{1}{\frac{1}{32} \pi D^4 (83\,000)} [450(2.5) + 1200(2.5)] (1000^2)$$

$$D = 51.89 \text{ mm}$$

Use **D = 251.54 mm** answer

Solution to Problem 323 Torsion

A shaft composed of segments AC, CD, and DB is fastened to rigid supports and loaded as shown in [Fig. P-323](#). For bronze, $G = 35 \text{ GPa}$; aluminum, $G = 28 \text{ GPa}$, and for steel, $G = 83 \text{ GPa}$. Determine the maximum shearing stress developed in each segment.

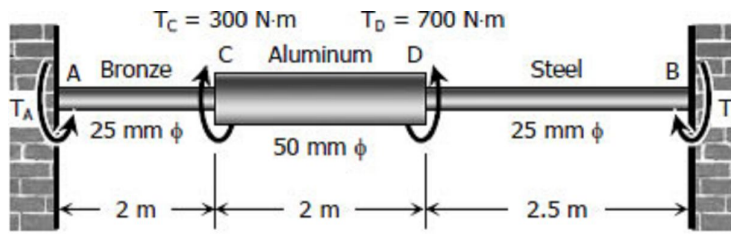
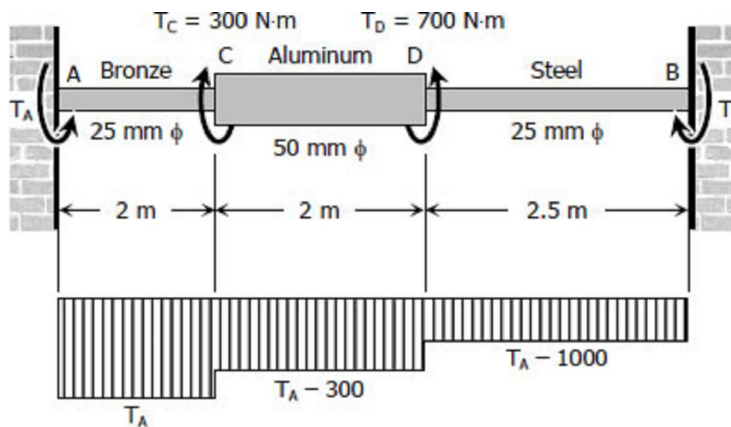

Figure P-323

Solution 323

Stress developed in each segment with respect to T_A :



The rotation of B relative to A is zero.

$$\theta_{A/B} = 0$$

$$\left(\sum \frac{TL}{JG} \right)_{A/B} = 0$$

$$\frac{T_A(2)(1000^2)}{\frac{1}{32}\pi(25^4)(35\,000)} + \frac{(T_A - 300)(2)(1000^2)}{\frac{1}{32}\pi(50^4)(28\,000)} + \frac{(T_A - 1000)(2.5)(1000^2)}{\frac{1}{32}\pi(25^4)(83\,000)} = 0$$

$$\frac{2T_A}{(25^4)(35)} + \frac{2(T_A - 300)}{(50^4)(28)} + \frac{2.5(T_A - 1000)}{(25^4)(83)} = 0$$

$$\frac{16T_A}{35} + \frac{T_A - 300}{28} + \frac{20(T_A - 1000)}{83} = 0$$

$$\frac{16}{25}T_A + \frac{1}{28}T_A - \frac{75}{7} + \frac{20}{83}T_A - \frac{20\,000}{83} = 0$$

$$\frac{8527}{11\,620}T_A = 251.678$$

$$T_A = 342.97 \text{ N} \cdot \text{m}$$

$$\Sigma M = 0$$

$$T_A + T_B = 300 + 700$$

$$342.97 + T_B = 1000$$

$$T_B = 657.03 \text{ N} \cdot \text{m}$$

$$T_{br} = 342.97 \text{ N} \cdot \text{m}$$

$$T_{al} = 342.97 - 300 = 42.97 \text{ N} \cdot \text{m}$$

$$T_{st} = 342.97 - 1000 = -657.03 \text{ N} \cdot \text{m} = -T_B \text{ (ok!)}$$

$$\tau_{max} = \frac{16T}{\pi D^3}$$

$$\tau_{br} = \frac{16(342.97)(1000)}{\pi(25^3)} = 111.79 \text{ MPa answer}$$

$$\tau_{al} = \frac{16(42.97)(1000)}{\pi(50^3)} = 1.75 \text{ MPa answer}$$

$$\tau_{al} = \frac{16(657.03)(1000)}{\pi(25^3)} = 214.16 \text{ MPa answer}$$

Solution to Problem 324 Torsion

The compound shaft shown in [Fig. P-324](#) is attached to rigid supports. For the bronze segment AB, the maximum shearing stress is limited to 8000 psi and for the steel segment BC, it is limited to 12 ksi. Determine the diameters of each segment so that each material will be simultaneously stressed to its permissible limit when a torque $T = 12 \text{ kip}\cdot\text{ft}$ is applied. For bronze, $G = 6 \times 10^6 \text{ psi}$ and for steel, $G = 12 \times 10^6 \text{ psi}$.

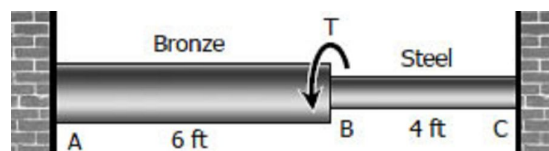

Figure P-324

Solution 324

$$\tau_{max} = \frac{16T}{\pi D^3}$$

For bronze:

$$8000 = \frac{16T_{br}}{\pi D_{br}^3}$$

$$T_{br} = 500\pi D_{br}^3 \text{ lb} \cdot \text{in}$$

For steel:

$$12\,000 = \frac{16T_{st}}{\pi D_{st}^3}$$

$$T_{st} = 750\pi D_{st}^3 \text{ lb} \cdot \text{in}$$

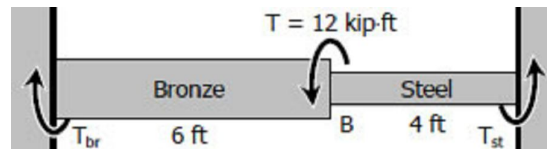

$$\Sigma M = 0$$

$$T_{br} + T_{st} = T$$

$$T_{br} + T_{st} = 12(1000)(12)$$

$$T_{br} + T_{st} = 144\,000 \text{ lb} \cdot \text{in}$$

$$500\pi D_{br}^3 + 750\pi D_{st}^3 = 144\,000$$

$$D_{br}^3 = 288/\pi + 1.5D_{st}^3 \rightarrow \text{Equation (1)}$$

$$\theta_{br} = \theta_{st}$$

$$\left(\frac{TL}{JG}\right)_{br} = \left(\frac{TL}{JG}\right)_{st}$$

$$\frac{T_{br}(6)}{\frac{1}{32}\pi D_{br}^4 (6 \times 10^6)} = \frac{T_{st}(4)}{\frac{1}{32}\pi D_{st}^4 (12 \times 10^6)}$$

$$\frac{T_{br}}{D_{br}^4} = \frac{T_{st}}{3D_{st}^4}$$

$$\frac{500\pi D_{br}^3}{D_{br}^4} = \frac{750\pi D_{st}^3}{3D_{st}^4}$$

$$\frac{500\pi D_{br}^3}{D_{br}^4} = \frac{750\pi D_{st}^3}{3D_{st}^4}$$

$$D_{st} = 0.5D_{br}$$

From Equation (1)

$$D_{br}^3 = 288/\pi - 1.5(0.5D_{br})^3$$

$$D_{br} = 288/\pi$$

$$D_{br} = 4.26 \text{ in. } \textit{answer}$$

$$D_{st} = 0.5(4.26) = 2.13 \text{ in. } \textit{answer}$$

Solution to Problem 325 Torsion

The two steel shaft shown in Fig. P-325, each with one end built into a rigid support have flanges rigidly attached to their free ends. The shafts are to be bolted together at their flanges. However, initially there is a 6° mismatch in the location of the bolt holes as shown in the figure. Determine the maximum shearing stress in each shaft after the shafts are bolted together. Use $G = 12 \times 10^6$ psi and neglect deformations of the bolts and flanges.

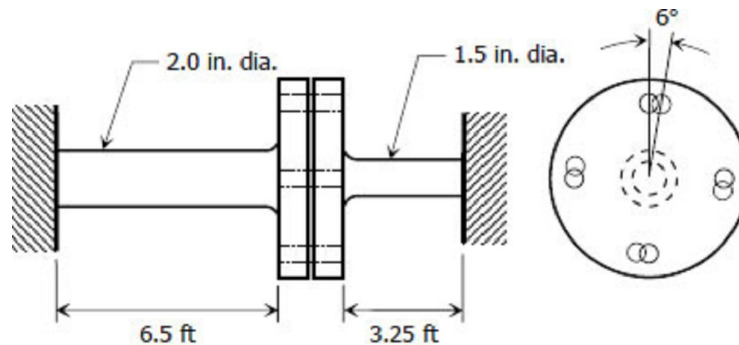

Figure P-325

Solution 325

$$\theta_{\text{of } 6.5' \text{ shaft}} + \theta_{\text{of } 3.25' \text{ shaft}} = 6^\circ$$

$$\left(\frac{TL}{JG}\right)_{\text{of } 6.5' \text{ shaft}} + \left(\frac{TL}{JG}\right)_{\text{of } 3.25' \text{ shaft}} = 6^\circ \left(\frac{\pi}{180^\circ}\right)$$

$$\frac{T(6.5)(12^2)}{\frac{1}{32}\pi(2^4)(12 \times 10^6)} + \frac{T(3.25)(12^2)}{\frac{1}{32}\pi(1.5^4)(12 \times 10^6)} = \frac{\pi}{30}$$

$$T = 817.32 \text{ lb} \cdot \text{ft}$$

$$\tau_{max} = \frac{16T}{\pi D^3}$$

$$\tau_{of\ 6.5'\ shaft} = \frac{16(817.32)(12)}{\pi(2^3)} = 6243.86\ \text{psi}\ \text{answer}$$

$$\tau_{of\ 3.25'\ shaft} = \frac{16(817.32)(12)}{\pi(1.5^3)} = 14\ 800.27\ \text{psi}\ \text{answer}$$

Flanged bolt couplings

In shaft connection called flanged bolt couplings ([see figure](#)), the torque is transmitted by the shearing force P created in the bolts that is assumed to be uniformly distributed. For any number of bolts n , the torque capacity of the coupling is

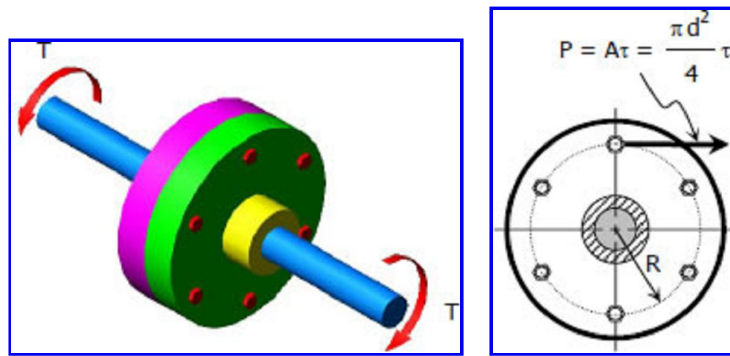

$$T = PRn = \frac{\pi d^2}{4} \tau Rn$$

If a coupling has two concentric rows of bolts, the torque capacity is

$$T = P_1 R_1 n_1 + P_2 R_2 n_2$$

where the subscript 1 refer to bolts on the outer circle and subscript 2 refer to bolts on the inner circle. See figure.

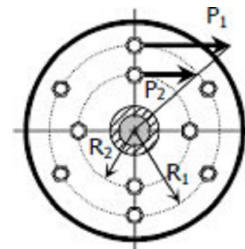

For rigid flanges, the shear deformations in the bolts are proportional to their radial distances from the shaft axis. The shearing strains are related by

$$\frac{\gamma_1}{R_1} = \frac{\gamma_2}{R_2}$$

Using [Hooke's law](#) for shear, $G = \tau/\gamma$, we have

$$\frac{\tau_1}{G_1 R_1} = \frac{\tau_2}{G_2 R_2} \text{ or } \frac{P_1/A_1}{G_1 R_1} = \frac{P_2/A_2}{G_2 R_2}$$

If the bolts on the two circles have the same area, $A_1 = A_2$, and if the bolts are made of the same material, $G_1 = G_2$, the relation between P_1 and P_2 reduces to

$$\frac{P_1}{R_1} = \frac{P_2}{R_2}$$

Solution to Problem 326 | Flanged bolt couplings

A flanged bolt coupling consists of ten 20-mm-diameter bolts spaced evenly around a bolt circle 400 mm in diameter. Determine the torque capacity of the coupling if the allowable shearing stress in the bolts is 40 MPa.

Solution 326

$$T = PRn = A\tau Rn = \frac{1}{4}\pi d^2 \tau Rn$$

$$T = \frac{1}{4}\pi(20^2)(40)(200)(10)$$

$$T = 8\,000\,000\pi \text{ N} \cdot \text{mm}$$

$$T = 8\pi \text{ kN} \cdot \text{m} = 25.13 \text{ kN} \cdot \text{m} \text{ answer}$$

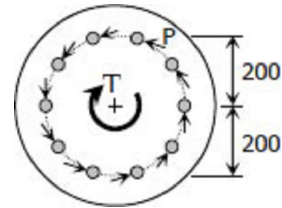

Solution to Problem 327 | Flanged bolt couplings

Problem 327

A flanged bolt coupling consists of ten steel 1/2-in.-diameter bolts spaced evenly around a bolt circle 14 in. in diameter. Determine the torque capacity of the coupling if the allowable shearing stress in the bolts is 6000 psi.

Solution 327

$$T = PRn = A\tau Rn = \frac{1}{4}\pi d^2 \tau Rn$$

$$T = \frac{1}{4}\pi(1/2)^2(6000)(7)(10)$$

$$T = 26250\pi \text{ lb} \cdot \text{in}$$

$$T = 2187.5\pi \text{ lb} \cdot \text{ft} = 6872.23 \text{ lb} \cdot \text{ft} \text{ answer}$$

Solution to Problem 328 | Flanged bolt couplings

A flanged bolt coupling consists of eight 10-mm-diameter steel bolts on a bolt circle 400 mm in diameter, and six 10-mm-diameter steel bolts on a concentric bolt circle 300 mm in diameter, as shown in [Fig. 3-7](#). What torque can be applied without exceeding a shearing stress of 60 MPa in the bolts?

Solution 328

For one bolt in the outer circle:

$$P_1 = A\tau = \frac{\pi(10^2)}{4} (60)$$

$$P_1 = 1500\pi \text{ N}$$

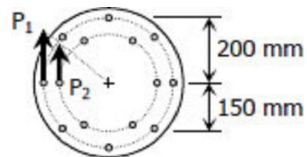

Figure 3-7

For one bolt in the inner circle:

$$\frac{P_1}{R_1} = \frac{P_2}{R_2}$$

$$\frac{1500\pi}{200} = \frac{P_2}{150}$$

$$P_2 = 1125\pi \text{ N}$$

$$T = P_1 R_1 n_1 + P_2 R_2 n_2$$

$$T = 1500\pi(200)(8) + 1125\pi(150)(6)$$

$$T = 3\,412\,500\pi \text{ N} \cdot \text{mm}$$

$$T = 3.4125\pi \text{ kN} \cdot \text{m} = 10.72 \text{ kN} \cdot \text{m} \text{ answer}$$

Solution to Problem 329 | Flanged bolt couplings

Problem 329

A torque of 700 lb-ft is to be carried by a flanged bolt coupling that consists of eight ½-in.-diameter steel bolts on a circle of diameter 12 in. and six ½-in.-diameter steel bolts on a circle of diameter 9 in. Determine the shearing stress in the bolts.

Solution 329

$$\frac{P_1}{R_1} = \frac{P_2}{R_2}$$

$$\frac{A\tau_1}{6} = \frac{A\tau_2}{4.5}$$

$$\tau_2 = 0.75\tau_1$$

$$T = P_1R_1n_1 + P_2R_2n_2$$

$$700(12) = \frac{1}{4}\pi(1/2)^2\tau_1(6)(8) + \frac{1}{4}\pi(1/2)^2\tau_2(4.5)(6)$$

$$8400 = 3\pi\tau_1 + 1.6875\pi(0.75\tau_1)$$

$$8400 = 13.4\tau_1$$

$$\tau_1 = 626.87 \text{ psi} \rightarrow \text{bolts in the outer circle } \textit{answer}$$

$$\tau_2 = 0.75(626.87) = 470.15 \text{ psi} \rightarrow \text{bolts in the inner circle } \textit{answer}$$

Solution to Problem 330 | Flanged bolt couplings

Determine the number of 10-mm-diameter steel bolts that must be used on the 400-mm bolt circle of the coupling described in [Prob. 328](#) to increase the torque capacity to 14 kN·m

Solution 330

$$T = P_1R_1n_1 + P_2R_2n_2$$

$$14(1000^2) = 1500\pi(200)n_1 + 1125\pi(150)(6)$$

$$n_1 = 11.48 \text{ say } 12 \text{ bolts } \textit{answer}$$

Solution to Problem 331 | Flanged bolt couplings

A flanged bolt coupling consists of six ½-in. steel bolts evenly spaced around a bolt circle 12 in. in diameter, and four ¾-in. aluminum bolts on a concentric bolt circle 8 in. in diameter. What torque can be applied without exceeding 9000 psi in the steel or 6000 psi in the aluminum? Assume $G_{st} = 12 \times 10^6$ psi and $G_{al} = 4 \times 10^6$ psi.

Solution 331

$$T = (PRn)_{st} + (PRn)_{al}$$

$$T = (A\tau Rn)_{st} + (A\tau Rn)_{al}$$

$$T = \frac{1}{4}\pi(1/2)^2\tau_{st}(6)(6) + \frac{1}{4}\pi(3/4)^2\tau_{al}(4)(4)$$

$$T = 2.25\pi\tau_{st} + 2.25\pi\tau_{al}$$

$$T = 2.25\pi(\tau_{st} + \tau_{al}) \rightarrow \text{Equation (1)}$$

$$\left(\frac{\tau}{GR}\right)_{st} = \left(\frac{\tau}{GR}\right)_{al}$$
$$\frac{\tau_{st}}{(12 \times 10^6)(6)} = \frac{\tau_{al}}{(4 \times 10^6)(4)}$$

$$\tau_{st} = \frac{9}{2}\tau_{al} \rightarrow \text{Equation (2a)}$$

$$\tau_{al} = \frac{2}{9}\tau_{st} \rightarrow \text{Equation (2b)}$$

Equations (1) and (2a)

$$T = 2.25\pi\left(\frac{9}{2}\tau_{al} + \tau_{al}\right) = 12.375\pi\tau_{al}$$

$$T = 12.375\pi(6000) = 74\,250\pi \text{ lb} \cdot \text{in}$$

$$T = 233.26 \text{ kip} \cdot \text{in}$$

Equations (1) and (2b)

$$T = 2.25\pi\left(\tau_{st} + \frac{2}{9}\tau_{st}\right) = 2.75\pi\tau_{st}$$

$$T = 2.25\pi(9000) = 24\,750\pi \text{ lb} \cdot \text{in}$$

$$T = 77.75 \text{ kip} \cdot \text{in}$$

Use **T = 77.75 kip·in** answer

Solution to Problem 332 | Flanged bolt couplings

In a rivet group subjected to a twisting couple T , show that the torsion formula $\tau = T\rho/J$ can be used to find the shearing stress τ at the center of any rivet. Let $J = \Sigma A\rho^2$, where A is the area of a rivet at the radial distance ρ from the centroid of the rivet group.

Solution 332

The shearing stress on each rivet is P/A

$$\tau = T\rho/J$$

Where:

$$T = PRn$$

$$\rho = R$$

$$J = \Sigma A\rho^2 = AR^2n$$

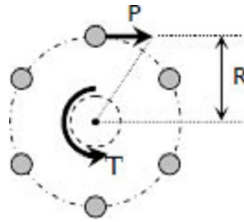

$$\tau = \frac{PRn(R)}{AR^2n}$$

$$\tau = \frac{P}{A} \text{ ok!}$$

This shows that $\tau = T\rho/J$ can be used to find the shearing stress at the center of any rivet.

Solution to Problem 333 | Flanged bolt couplings

A plate is fastened to a fixed member by four 20-mm-diameter rivets arranged as shown in [Fig. P-333](#). Compute the maximum and minimum shearing stress developed.

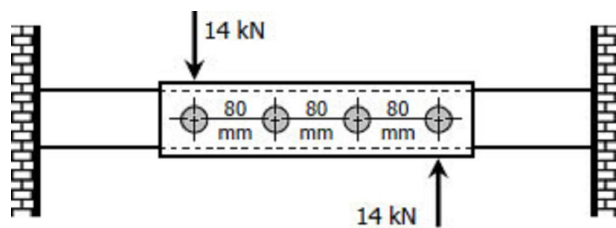
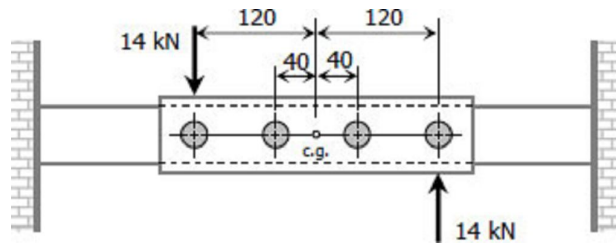

Figure P-333

Solution 333

$$\tau = \frac{T\rho}{J}$$



Where:

$$T = 14(1000)(120) = 1\,680\,000 \text{ N} \cdot \text{mm}$$

$$J = \Sigma A \rho^2 = \frac{1}{4} \pi (20)^2 [2(40^2) + 2(120^2)]$$

$$J = 3\,200\,000 \pi \text{ mm}^4$$

Maximum shearing stress ($\rho = 120 \text{ mm}$):

$$\tau_{max} = \frac{1\,680\,000(120)}{3\,200\,000 \pi}$$

$$\tau_{max} = 20.05 \text{ MPa } \textit{answer}$$

Minimum shearing stress ($\rho = 40 \text{ mm}$):

$$\tau_{min} = \frac{1\,680\,000(40)}{3\,200\,000 \pi}$$

$$\tau_{min} = 6.68 \text{ MPa } \textit{answer}$$

Solution to Problem 334 | Flanged bolt couplings

Six 7/8-in-diameter rivets fasten the plate in [Fig. P-334](#) to the fixed member. Using the results of [Prob. 332](#), determine the average shearing stress caused in each rivet by the 14 kip loads. What additional loads P can be applied before the shearing stress in any rivet exceeds 8000 psi?

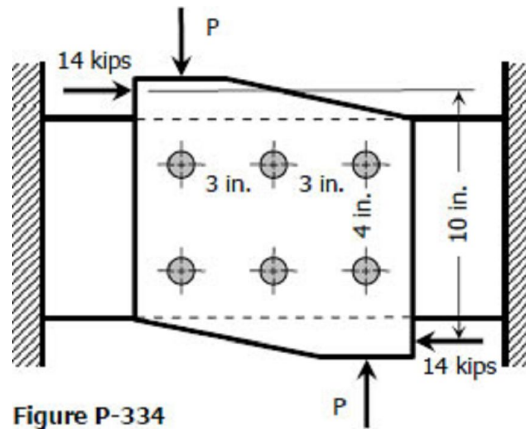

Solution 334

Without the loads P:

$$\tau = \frac{T\rho}{J}$$

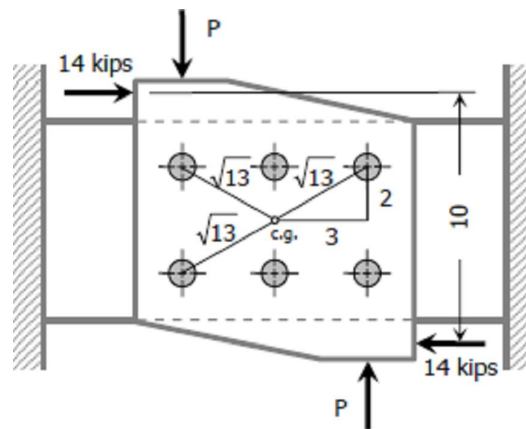

Where:

$$T = 14(10) = 140 \text{ kip} \cdot \text{in}$$

$$\rho = \sqrt{13} \text{ in}$$

$$J = \Sigma A\rho^2 = \frac{1}{4}\pi\left(\frac{7}{8}\right)^2 [4(\sqrt{13}) + 2(2)^2] = 36.08 \text{ in}^4$$

$$\tau_{\text{maximum}} = \frac{140\sqrt{13}}{36.08} = 14.0 \text{ ksi answer}$$

$$\tau_{\text{minimum}} = \frac{140(2)}{36.08} = 7.76 \text{ ksi answer}$$

With the loads P, two cases will arise:

1st case (P < 14 kips)

$$T = 10(14) - 6P = (140 - 6P) \text{ kip} \cdot \text{in}$$

$$\tau = \frac{T\rho}{J}$$

$$8000 = \frac{(140 - 6P)(1000)(\sqrt{13})}{36.08}$$

$$80.05 = 140 - 6P$$

$$P = 10.0 \text{ kips } \textit{answer}$$

2nd case (P > 14 kips)

$$T = 6P - 10(14) = (6P - 140) \text{ kip} \cdot \text{in}$$

$$\tau = \frac{T\rho}{J}$$

$$8000 = \frac{(6P - 140)(1000)(\sqrt{13})}{36.08}$$

$$80.05 = 6P - 140$$

$$P = 36.68 \text{ kips } \textit{answer}$$

Solution to Problem 335 | Flanged bolt couplings

The plate shown in [Fig. P-335](#) is fastened to the fixed member by five 10-mm-diameter rivets. Compute the value of the loads P so that the average shearing stress in any rivet does not exceed 70 MPa. (Hint: Use the results of [Prob. 332](#).)

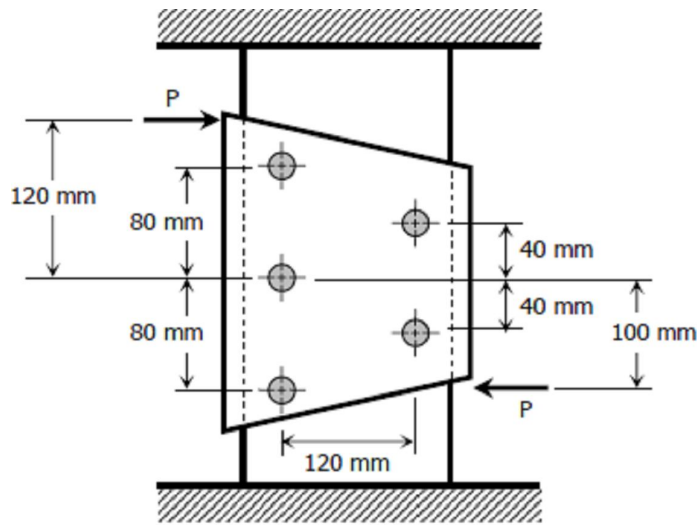

Figure P-335

Solution 335

Solving for location of centroid of rivets:

$$AX_G = \sum ax$$

Where

$$A = \frac{1}{2}(80 + 160)(80) = 9600 \text{ mm}^2$$

$$a_1 = a_2 = a_3 = \frac{1}{2}(80)(80) = 3200 \text{ mm}^2$$

$$x_1 = x_3 = \frac{1}{3}(80) = 80/3 \text{ mm}$$

$$x_2 = \frac{2}{3}(80) = 160/3 \text{ mm}$$

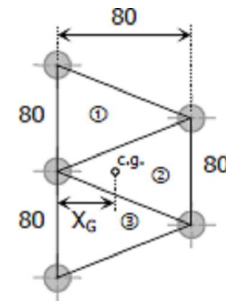

$$9600X_G = 3200(80/3) + 3200(160/3) + 3200(80/3)$$

$$X_G = 320/9 \text{ mm}$$

$$r_1 = \sqrt{(320/9)^2 + 80^2} = 87.54 \text{ mm}$$

$$r_2 = \sqrt{(80 - 320/9)^2 + 40^2} = 59.79 \text{ mm}$$

$$J = \sum A \rho^2 = \frac{1}{4}\pi(10^2)(2r_1^2 + 2r_2^2 + X_G^2)$$

$$J = \frac{1}{4}\pi(10^2) [2(87.54)^2 + 2(59.79)^2 + (320/9)^2]$$

$$J = 1\,864\,565.79 \text{ mm}^4$$

$$T = (120 + 100)P = 220P$$

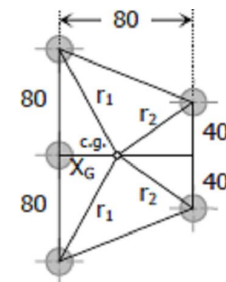

The critical rivets are at distance r_1 from centroid:

$$\tau = \frac{T\rho}{J}$$

$$70 = \frac{220P(87.54)}{1\,864\,565.79}$$

$$P = 6777.14 \text{ N } \textit{answer}$$

Torsion of thin-walled tube

The torque applied to thin-walled tubes is expressed as

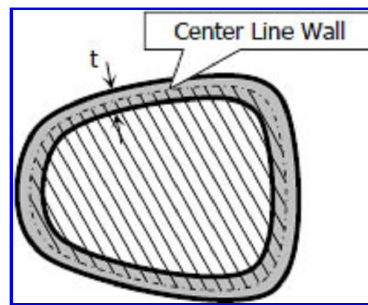

$$T = 2Aq$$

where T is the torque in $\text{N}\cdot\text{mm}$, A is the area enclosed by the center line of the tube (as shown in the stripe-filled portion) in mm^2 , and q is the shear flow in N/mm .

The average shearing stress across any thickness t is

$$\tau = \frac{q}{t} = \frac{T}{2At}$$

Thus, torque T can also be expressed as

$$T = 2At\tau$$

Solution to Problem 337 | Torsion of thin-walled tube

Problem 337

A torque of 600 N·m is applied to the rectangular section shown in [Fig. P-337](#). Determine the wall thickness t so as not to exceed a shear stress of 80 MPa. What is the shear stress in the short sides? Neglect stress concentration at the corners.

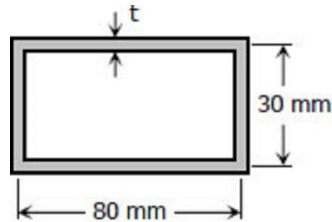

Figure P-337

Solution 337

$$T = 2At\tau$$

Where:

$$T = 600 \text{ N} \cdot \text{m} = 600\,000 \text{ N} \cdot \text{mm}$$

$$A = 30(80) = 2400 \text{ mm}^2$$

$$\tau = 80 \text{ MPa}$$

$$600\,000 = 2(2400)(t)(80)$$

$$t = 1.5625 \text{ mm } \textit{answer}$$

At any convenient center O within the section, the farthest side is the shortest side, thus, it is induced with the maximum allowable shear stress of **80 MPa**.

Solution to Problem 338 | Torsion of thin-walled tube

A tube 0.10 in. thick has an elliptical shape shown in [Fig. P-338](#). What torque will cause a shearing stress of 8000 psi?

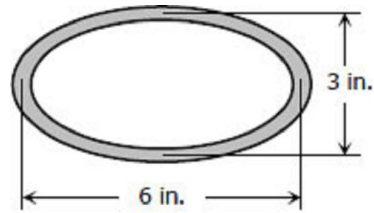

Figure P-338

Solution 338

$$T = 2At\tau$$

Where:

$$A = \pi ab = \pi(3)(1.5) = 4.5\pi \text{ in}^2$$

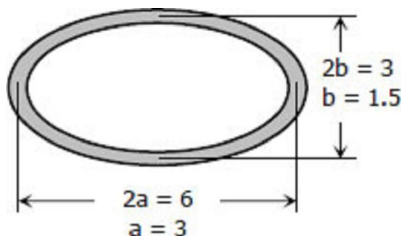

$$T = 0.10 \text{ in}$$

$$\tau = 8000 \text{ psi}$$

$$T = 2(4.5\pi)(0.10)(8000)$$

$$T = 22619.47 \text{ lb} \cdot \text{in}$$

$$T = 22.62 \text{ kip} \cdot \text{in} \text{ answer}$$

Solution to Problem 339 | Torsion of thin-walled tube

A torque of 450 lb · ft is applied to the square section shown in [Fig. P-339](#). Determine the smallest permissible dimension a if the shearing stress is limited to 6000 psi.

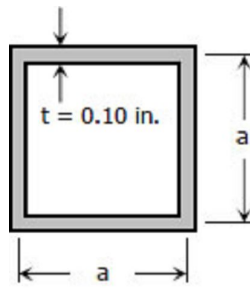

Figure P-339

Problem 339

$$T = 2At\tau$$

Where:

$$T = 450 \text{ lb} \cdot \text{ft} = 450(12) \text{ lb} \cdot \text{in}$$

$$A = a^2$$

$$\tau = 6000 \text{ psi}$$

$$450(12) = 2a^2(0.10)(6000)$$

$$a = 2.12 \text{ in } \textit{answer}$$

Solution to Problem 340 | Torsion of thin-walled tube

A tube 2 mm thick has the shape shown in [Fig. P-340](#). Find the shearing stress caused by a torque of 600 N·m.

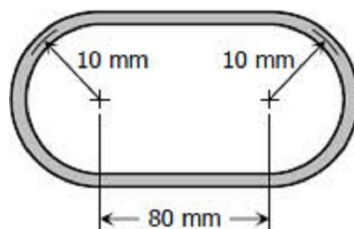

Figure P-340

Solution 340

$$T = 2At\tau$$

Where:

$$A = \pi(10^2) + 80(20) = 1914.16 \text{ mm}^2$$

$$t = 2 \text{ mm}$$

$$T = 600 \text{ N} \cdot \text{m} = 600\,000 \text{ N} \cdot \text{mm}$$

$$600\,000 = 2(1914.16)(2)\tau$$

$$\tau = 78.36 \text{ MPa } \textit{answer}$$

Solution to Problem 341 | Torsion of thin-walled tube

Derive the torsion formula $\tau = T\rho / J$ for a solid circular section by assuming the section is composed of a series of concentric thin circular tubes. Assume that the shearing stress at any point is proportional to its radial distance.

Solution 341

$$T = 2At\tau$$

Where:

$$T = dT; A = \pi\rho^2; t = d\rho$$

$$\frac{\tau}{\rho} = \frac{\tau_{max}}{r}; \tau = \frac{\tau_{max}\rho}{r}$$

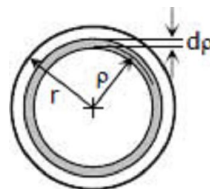

$$dT = 2\pi(\rho^2)d\rho \left(\frac{\tau_{max}\rho}{r} \right)$$

$$T = \frac{2\pi\tau_{max}}{r} \int_0^r \rho^3 d\rho$$

$$T = \frac{2\pi\tau_{max}}{r} \left[\frac{\rho^4}{4} \right]_0^r$$

$$T = \frac{2\pi\tau_{max}}{r} \left(\frac{r^4}{4} \right)$$

$$T = \frac{\tau_{max}}{r} \left(\frac{\pi r^4}{2} \right)$$

$$T = \frac{\tau_{max}}{r} J$$

$$\tau_{max} = \frac{Tr}{J} \text{ and it follows that } \tau_{max} = \frac{T\rho}{J} \text{ ok!}$$

Helical Springs

When close-coiled helical spring, composed of a wire of round rod of diameter d wound into a helix of mean radius R with n number of turns, is subjected to an axial load P produces the following stresses and elongation:

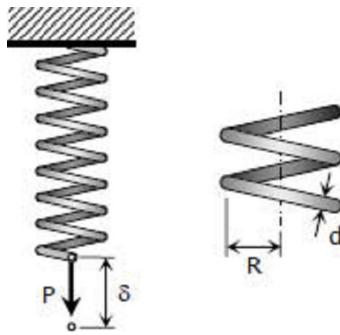

The maximum shearing stress is the sum of the direct shearing stress $\tau_1 = P/A$ and the torsional shearing stress $\tau_2 = Tr/J$, with $T = PR$.

$$\tau = \tau_1 + \tau_2 = \frac{P}{\pi d^2/4} + \frac{16PR}{\pi d^3}$$

$$\tau = \frac{16PR}{\pi d^3} \left(1 + \frac{d}{4R} \right)$$

This formula neglects the curvature of the spring. This is used for light spring where the ratio $d/4R$ is small.

For heavy springs and considering the curvature of the spring, a more precise formula is given by: (A.M. Wahl Formula)

$$\tau = \frac{16PR}{\pi d^3} \left(\frac{4m-1}{4m-4} + \frac{0.615}{m} \right)$$

where m is called the **spring index** and $(4m-1)/(4m-4)$ is the **Wahl Factor**.

The elongation of the bar is

$$\delta = \frac{64PR^3n}{Gd^4}$$

Notice that the deformation δ is directly proportional to the applied load P . The ratio of P to δ is called the **spring constant** k and is equal to

$$k = \frac{P}{\delta} = \frac{Gd^4}{64R^3n} \text{ N/mm}$$

Springs in Series

For two or more springs with spring laid in series, the resulting spring constant k is given by

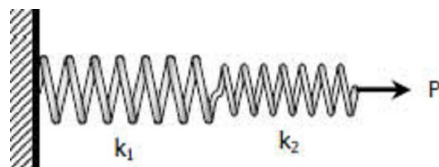

$$1/k = 1/k_1 + 1/k_2 + \dots$$

where k_1, k_2, \dots are the spring constants for different springs.

Springs in Parallel

For two or more springs in parallel, the resulting spring constant is

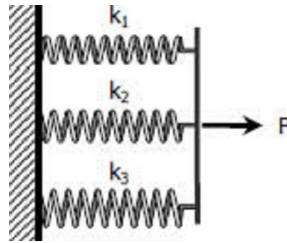

$$k = k_1 + k_2 + \dots$$

Solution to Problem 343 | Helical Springs

Determine the maximum shearing stress and elongation in a helical steel spring composed of 20 turns of 20-mm-diameter wire on a mean radius of 90 mm when the spring is supporting a load of 1.5 kN. Use Eq. (3-10) and $G = 83 \text{ GPa}$.

Problem 343

$$\tau_{max} = \frac{16PR}{\pi d^3} \left(\frac{4m-1}{4m-4} + \frac{0.615}{m} \right) \rightarrow \text{Equation (3-10)}$$

Where:

$$P = 1.5 \text{ kN} = 1500 \text{ N}; R = 90 \text{ mm}$$

$$d = 20 \text{ mm}; n = 20 \text{ turns}$$

$$m = 2R/d = 2(90)/20 = 9$$

$$\tau_{max} = \frac{16(1500)(90)}{\pi(20^3)} \left(\frac{4(9) - 1}{4(9) - 4} + \frac{0.615}{9} \right)$$

$$\tau_{max} = 99.87 \text{ MPa } \textit{answer}$$

$$\delta = \frac{64PR^3n}{Gd^4} = \frac{64(1500)(90^3)(20)}{83\,000(20^4)}$$

$$\delta = 105.4 \text{ mm } \textit{answer}$$

Solution to Problem 344 | Helical Springs

Determine the maximum shearing stress and elongation in a bronze helical spring composed of 20 turns of 1.0-in.-diameter wire on a mean radius of 4 in. when the spring is supporting a load of 500 lb. Use Eq. (3-10) and $G = 6 \times 10^6$ psi.

Solution 344

$$\tau_{max} = \frac{16PR}{\pi d^3} \left(\frac{4m - 1}{4m - 4} + \frac{0.615}{m} \right) \rightarrow \text{Equation (3-10)}$$

Where

$P = 500$ lb; $R = 4$ in

$d = 1$ in; $n = 20$ turns

$m = 2R/d = 2(4)/1 = 8$

$$\tau_{max} = \frac{16(500)(4)}{\pi(1^3)} \left[\frac{4(8) - 1}{4(8) - 4} + \frac{0.615}{8} \right]$$

$$\tau_{max} = 12\,060.3 \text{ psi} = 12.1 \text{ ksi } \textit{answer}$$

$$\delta = \frac{64PR^3n}{Gd^4} = \frac{64(500)(4^3)(20)}{(6 \times 10^6)(1^4)}$$

$$\delta = 6.83 \text{ in } \textit{answer}$$

Solution to Problem 345 | Helical Springs

A helical spring is fabricated by wrapping wire 3/4 in. in diameter around a forming cylinder 8 in. in diameter. Compute the number of turns required to permit an elongation of 4 in. without exceeding a shearing stress of 18 ksi. Use Eq. (3-9) and $G = 12 \times 10^6$ psi.

Solution 345

$$\tau_{max} = \frac{16PR}{\pi d^3} \left(1 + \frac{d}{4R} \right) \rightarrow \text{Equation (3-9)}$$

$$18\,000 = \frac{16P(4)}{\pi(3/4)^3} \left[1 + \frac{3/4}{4(4)} \right]$$

$$P = 356.07 \text{ lb}$$

$$\delta = \frac{64PR^3n}{Gd^4}$$

$$4 = \frac{64(356.07)(4^3)n}{(12 \times 10^6)(3/4)^3}$$

$$n = 13.88 \text{ say } 14 \text{ turns } \textit{answer}$$

Solution to Problem 346 | Helical Springs

Compute the maximum shearing stress developed in a phosphor bronze spring having mean diameter of 200 mm and consisting of 24 turns of 200-mm diameter wire when the spring is stretched 100 mm. Use Eq. (3-10) and $G = 42$ GPa.

Solution 346

$$\delta = \frac{64PR^3n}{Gd^4}$$

Where

$$\delta = 100 \text{ mm}; R = 100 \text{ mm}$$

$$d = 20 \text{ mm}; n = 24 \text{ turns}$$

$$G = 42\,000 \text{ MPa}$$

$$100 = \frac{64P(100^3)24}{42\,000(20^4)}$$

$$P = 437.5 \text{ N}$$

$$\tau_{max} = \frac{16PR}{\pi d^3} \left(\frac{4m-1}{4m-4} + \frac{0.615}{m} \right) \rightarrow \text{Equation (3-10)}$$

Where

$$m = 2R/d = 2(100)/20 = 10$$

$$\tau_{max} = \frac{16(437.5)(100)}{\pi(20^3)} \left[\frac{4(10)-1}{4(10)-4} + \frac{0.615}{10} \right]$$

$$\tau_{max} = 31.89 \text{ MPa } \textit{answer}$$

Solution to Problem 347 | Helical Springs

Two steel springs arranged in series as shown in [Fig. P-347](#) supports a load P . The upper spring has 12 turns of 25-mm-diameter wire on a mean radius of 100 mm. The lower spring consists of 10 turns of 20-mm diameter wire on a mean radius of 75 mm. If the maximum shearing stress in either spring must not exceed 200 MPa, compute the maximum value of P and the total elongation of the assembly. Use Eq. (3-10) and $G = 83 \text{ GPa}$. Compute the equivalent spring constant by dividing the load by the total elongation.



Figure P-347

Solution 347

$$\tau_{max} = \frac{16PR}{\pi d^3} \left(\frac{4m-1}{4m-4} + \frac{0.615}{m} \right) \rightarrow \text{Equation (3-10)}$$

For Spring (1)

$$200 = \frac{16P(100)}{\pi(25^3)} \left[\frac{4(8)-1}{4(8)-4} + \frac{0.615}{8} \right]$$

$$P = 5182.29 \text{ N}$$

For Spring (2)

$$200 = \frac{16P(75)}{\pi(20^3)} \left[\frac{4(7.5)-1}{4(7.5)-4} + \frac{0.615}{7.5} \right]$$

$$P = 3498.28 \text{ N}$$

Use $P = 3498.28 \text{ N}$ *answer*

Total elongation:

$$\delta = \delta_1 + \delta_2$$

$$\delta = \left(\frac{64PR^3n}{Gd^4} \right)_1 + \left(\frac{64PR^3n}{Gd^4} \right)_2$$

$$\delta = \frac{64(3498.28)(100^3)12}{83\,000(25^4)} + \frac{64(3498.28)(75^3)10}{83\,000(20^4)}$$

$$\delta = 153.99 \text{ mm} \text{ } \textit{answer}$$

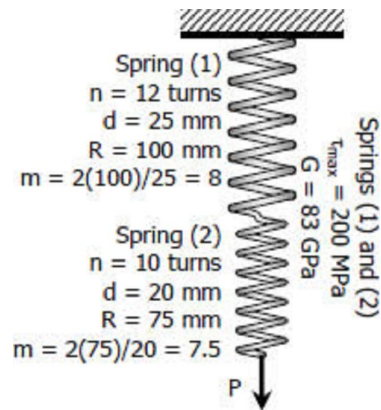

Equivalent spring constant, $k_{\text{equivalent}}$:

$$k_{\text{equivalent}} = \frac{P}{\delta} = \frac{3498.28}{153.99}$$

$$k_{\text{equivalent}} = 22.72 \text{ N/mm } \textit{answer}$$

Solution to Problem 348 | Helical Springs

A rigid bar, pinned at O, is supported by two identical springs as shown in [Fig. P-348](#). Each spring consists of 20 turns of 3/4-in-diameter wire having a mean diameter of 6 in. Determine the maximum load W that may be supported if the shearing stress in the springs is limited to 20 ksi. Use Eq. (3-9).

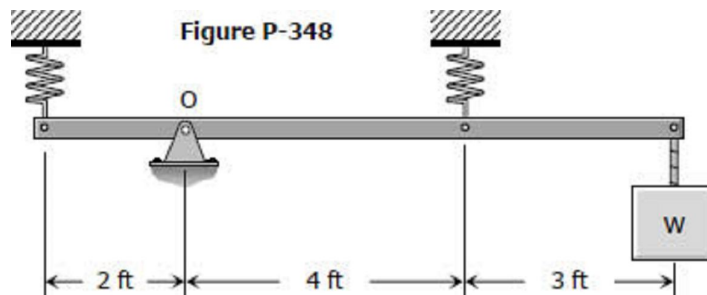

Solution 348

$$\tau_{\text{max}} = \frac{16PR}{\pi d^3} \left(1 + \frac{d}{4R} \right) \rightarrow \text{Equation (3-9)}$$

$$20\,000 = \frac{16P(3)}{\pi(3/4)^3} \left[1 + \frac{3/4}{4(3)} \right]$$

$$P = 519.75 \text{ lb}$$

For this problem, the critical spring is the one subjected to tension. Use $P_2 = 519.75 \text{ lb}$.

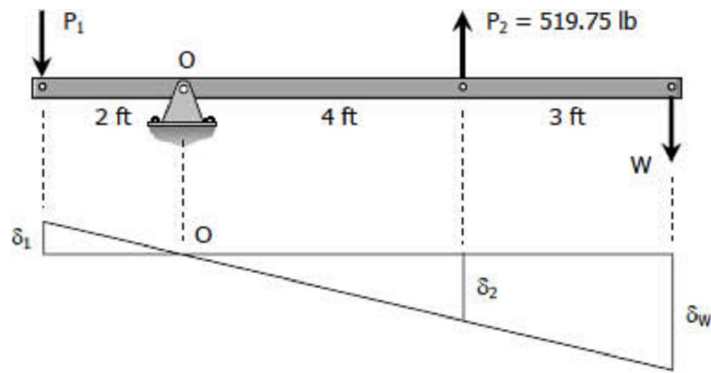

$$\frac{\delta_1}{2} = \frac{\delta_2}{4}$$

$$\delta_1 = \frac{1}{2}\delta_2$$

$$\frac{64P_1R^3n}{Gd^4} = \frac{1}{2} \left(\frac{64P_2R^3n}{Gd^4} \right)$$

$$P_1 = \frac{1}{2}P_2 = \frac{1}{2}(519.75)$$

$$P_1 = 259.875 \text{ lb}$$

$$\Sigma M_O = 0$$

$$7W = 2P_1 + 4P_2$$

$$7W = 2(259.875) + 4(519.75)$$

$$W = 371.25 \text{ lb } \textit{answer}$$

Solution to Problem 349 | Helical Springs

A rigid bar, hinged at one end, is supported by two identical springs as shown in [Fig. P-349](#). Each spring consists of 20 turns of 10-mm wire having a mean diameter of 150 mm. Compute the maximum shearing stress in the springs, using Eq. (3-9). Neglect the mass of the rigid bar.

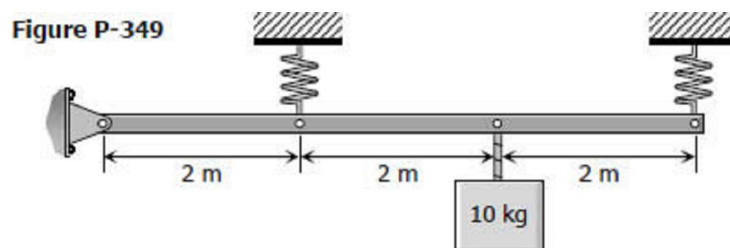

Solution 349

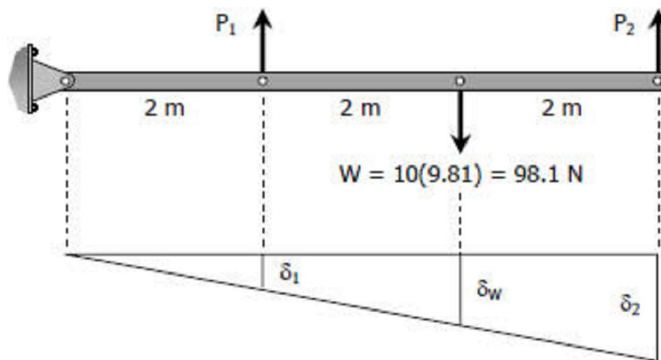

$$\frac{\delta_1}{2} = \frac{\delta_2}{6}$$

$$\delta_1 = \frac{1}{3}\delta_2$$

$$\frac{64P_1R^3n}{Gd^4} = \frac{1}{3} \left(\frac{64P_2R^3n}{Gd^4} \right)$$

$$P_1 = \frac{1}{3}P_2$$

$$\Sigma M_{\text{at hinged support}} = 0$$

$$2P_1 + 6P_2 = 4(98.1)$$

$$2\left(\frac{1}{3}P_2\right) + 6P_2 = 4(98.1)$$

$$P_2 = 58.86 \text{ N}$$

$$P_1 = \frac{1}{3}(58.86) = 19.62 \text{ N}$$

$$\tau = \frac{16PR}{\pi d^3} \left(1 + \frac{d}{4R} \right) \rightarrow \text{Equation (3-9)}$$

For spring at left:

$$\tau_{\text{max1}} = \frac{16(19.62)(75)}{\pi(10^3)} \left[1 + \frac{10}{4(75)} \right]$$

$$\tau_{\text{max1}} = 7.744 \text{ MPa answer}$$

For spring at right:

$$\tau_{max2} = \frac{16(58.86)(75)}{\pi(10^3)} \left[1 + \frac{10}{4(75)} \right]$$

$$\tau_{max2} = 23.232 \text{ MPa } \textit{answer}$$

Solution to Problem 350 | Helical Springs

As shown in [Fig. P-350](#), a homogeneous 50-kg rigid block is suspended by the three springs whose lower ends were originally at the same level. Each steel spring has 24 turns of 10-mm-diameter on a mean diameter of 100 mm, and $G = 83 \text{ GPa}$. The bronze spring has 48 turns of 20-mm-diameter wire on a mean diameter of 150 mm, and $G = 42 \text{ GPa}$. Compute the maximum shearing stress in each spring using Eq. (3-9).

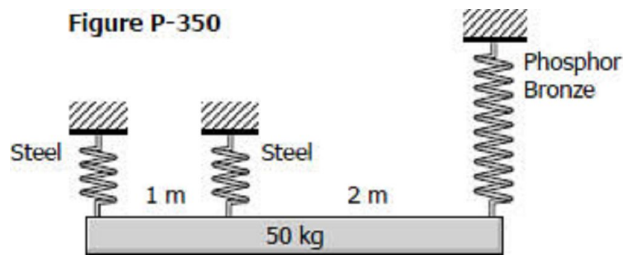

Solution 350

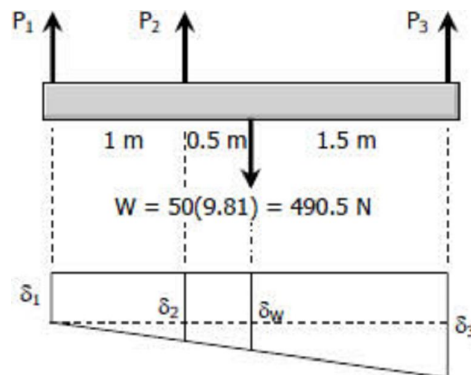

$$\Sigma F_V = 0$$

$$P_1 + P_2 + P_3 = 490.5 \rightarrow \text{Equation (1)}$$

$$\Sigma M_1 = 0$$

$$P_2(1) + P_3(3) = 490.5(1.5)$$

$$P_2 + 3P_3 = 735.75 \rightarrow \text{Equation (2)}$$

$$\frac{\delta_2 - \delta_1}{1} = \frac{\delta_3 - \delta_1}{3}$$

$$\delta_2 = \frac{1}{3}\delta_3 + \frac{2}{3}\delta_1$$

$$\frac{64P_2(50^3)(24)}{83\,000(10^4)} = \frac{1}{3} \left[\frac{64P_3(75^3)(48)}{42\,000(20^4)} \right] + \frac{2}{3} \left[\frac{64P_1(50^3)(24)}{83\,000(10^4)} \right]$$

$$\frac{3}{830}P_2 = \frac{9}{8960}P_3 + \frac{1}{415}P_1$$

$$\frac{3}{166}P_2 = \frac{9}{1792}P_3 + \frac{1}{83}P_1 \rightarrow \text{Equation (3)}$$

From Equation (1)

$$P_1 = 490.5 - P_2 - P_3$$

Substitute P1 to Equation (3)

$$\frac{3}{166}P_2 = \frac{9}{1792}P_3 + \frac{1}{83}(490.5 - P_2 - P_3)$$

$$\frac{3}{166}P_2 = \frac{9}{1792}P_3 + \frac{981}{166} - \frac{1}{83}P_2 - \frac{1}{83}P_3$$

$$\frac{5}{166}P_2 = \frac{981}{166} - \frac{1045}{148\,736}P_3 \rightarrow \text{Equation (4)}$$

From Equation (2)

$$P_2 = 735.75 - 3P_3 = \frac{2943}{4} - 3P_3$$

Substitute P2 to Equation (4)

$$\frac{5}{166} \left(\frac{2943}{4} - 3P_3 \right) = \frac{981}{166} - \frac{1045}{148\,736}P_3$$

$$\left(\frac{1045}{148\,736} - \frac{5}{166} \right) P_3 = \frac{981}{166} - \frac{14\,715}{664}$$

$$P_3 = 195.01 \text{ N}$$

$$P_2 = 735.75 - 3(195.01) = 150.72 \text{ N}$$

$$P_1 = 490.5 - 150.72 - 195.01 = 144.77 \text{ N}$$

$$\tau_{max} = \frac{16PR}{\pi d^3} \left(1 + \frac{d}{4R} \right)$$

For steel at left:

$$\tau_{max1} = \frac{16(144.77)(50)}{\pi(10^3)} \left[1 + \frac{10}{4(50)} \right] = 38.709 \text{ MPa} \text{ answer}$$

For steel at right:

$$\tau_{max2} = \frac{16(150.72)(50)}{\pi(10^3)} \left[1 + \frac{10}{4(50)} \right] = 40.300 \text{ MPa} \text{ answer}$$

For phosphor bronze:

$$\tau_{max3} = \frac{16(195.01)(75)}{\pi(20^3)} \left[1 + \frac{20}{4(75)} \right] = 9.932 \text{ MPa} \text{ answer}$$

Chapter 4 - Shear and Moment in Beams

Definition of a Beam

A beam is a bar subject to forces or couples that lie in a plane containing the longitudinal section of the bar. According to determinacy, a beam may be determinate or indeterminate.

Statically Determinate Beams

Statically determinate beams are those beams in which the reactions of the supports may be determined by the use of the equations of static equilibrium. The beams shown below are examples of statically determinate beams.

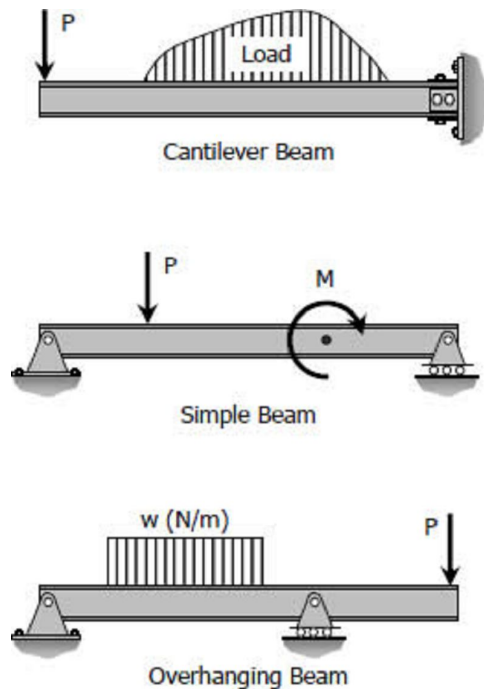

Statically Indeterminate Beams

If the number of reactions exerted upon a beam exceeds the number of equations in static equilibrium, the beam is said to be statically indeterminate. In order to solve the reactions of the beam, the static equations must be supplemented by equations based upon the elastic deformations of the beam.

The degree of indeterminacy is taken as the difference between the number of reactions to the number of equations in static equilibrium that can be applied. In the case of the propped beam shown, there are three reactions R_1 , R_2 , and M and only two equations ($\Sigma M = 0$ and $\Sigma F_v = 0$) can be applied, thus the beam is indeterminate to the first degree ($3 - 2 = 1$).

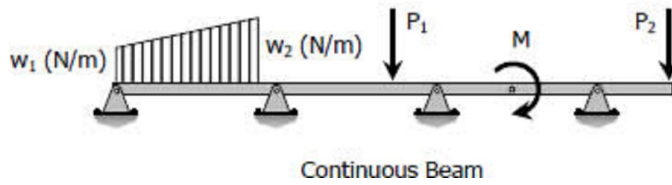
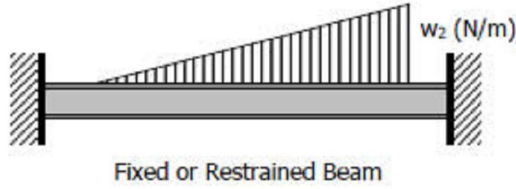
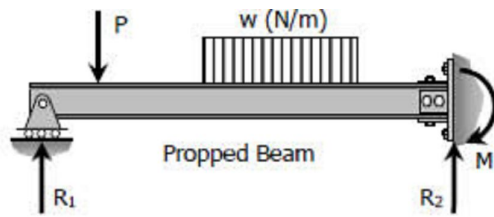

Types of Loading

Loads applied to the beam may consist of a concentrated load (load applied at a point), uniform load, uniformly varying load, or an applied couple or moment. These loads are shown in the following figures.

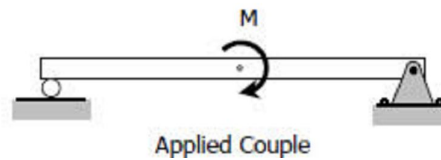
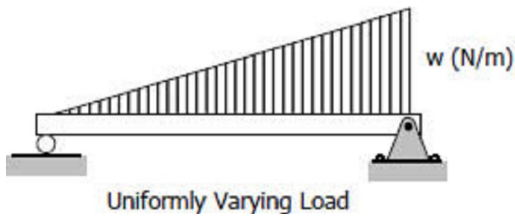
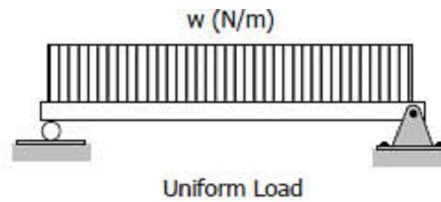
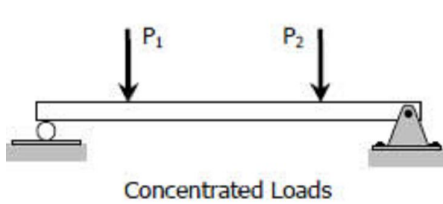

Shear and Moment Diagrams

Shear and Moment Diagrams

Consider a simple beam shown of length L that carries a uniform load of w (N/m) throughout its length and is held in equilibrium by reactions R_1 and R_2 . Assume that the beam is cut at point C a distance of x from the left support and the portion of the beam to the right of C be removed. The portion removed must then be replaced by vertical shearing force V together with a couple M to hold the left portion of the bar in equilibrium under the action of R_1 and w .

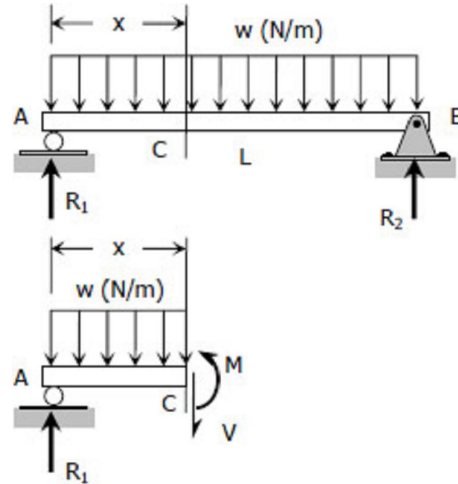

The couple M is called the resisting moment or moment and the force V is called the resisting shear or shear. The sign of V and M are taken to be positive if they have the senses indicated above.

INSTRUCTION:

Write shear and moment equations for the beams in the following problems. In each problem, let x be the distance measured from left end of the beam. Also, draw shear and moment diagrams, specifying values at all change of loading positions and at points of zero shear. Neglect the mass of the beam in each problem.

Solution to Problem 403 | Shear and Moment Diagrams

Problem 403

Beam loaded as shown in [Fig. P-403](#). See the [instruction](#).

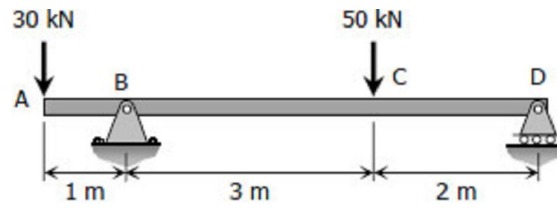

Figure P-403

Solution 403

From the load diagram:

$$\sum M_B = 0$$

$$5R_D + 1(30) = 3(50)$$

$$R_D = 24 \text{ kN}$$

$$\sum M_D = 0$$

$$5R_B = 2(50) + 6(30)$$

$$R_B = 56 \text{ kN}$$

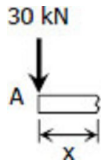

Segment AB:

$$V_{AB} = -30 \text{ kN}$$

$$M_{AB} = -30x \text{ kN} \cdot \text{m}$$

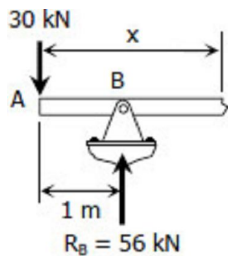

Segment BC:

$$V_{BC} = -30 + 56$$

$$V_{BC} = 26 \text{ kN}$$

$$M_{BC} = -30x + 56(x-1)$$

$$M_{BC} = 26x - 56 \text{ kN} \cdot \text{m}$$

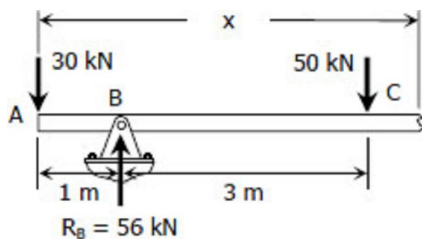

Segment CD:

$$V_{CD} = -30 + 56 - 50$$

$$V_{CD} = -24 \text{ kN}$$

$$M_{CD} = -30x + 56(x-1) - 50(x-4)$$

$$M_{CD} = -30x + 56x - 56 - 50x + 200$$

$$M_{CD} = -24x + 144 \text{ kN} \cdot \text{m}$$

To draw the Shear Diagram:

1. In segment AB, the shear is uniformly distributed over the segment at a magnitude of -30 kN.
2. In segment BC, the shear is uniformly distributed at a magnitude of 26 kN.
3. In segment CD, the shear is uniformly distributed at a magnitude of -24 kN.

To draw the Moment Diagram:

1. The equation $M_{AB} = -30x$ is linear, at $x = 0$, $M_{AB} = 0$ and at $x = 1$ m, $M_{AB} = -30$ kN·m.
2. $M_{BC} = 26x - 56$ is also linear. At $x = 1$ m, $M_{BC} = -30$ kN·m; at $x = 4$ m, $M_{BC} = 48$ kN·m. When $M_{BC} = 0$, $x = 2.154$ m, thus the moment is zero at 1.154 m from B.
3. $M_{CD} = -24x + 144$ is again linear. At $x = 4$ m, $M_{CD} = 48$ kN·m; at $x = 6$ m, $M_{CD} = 0$.

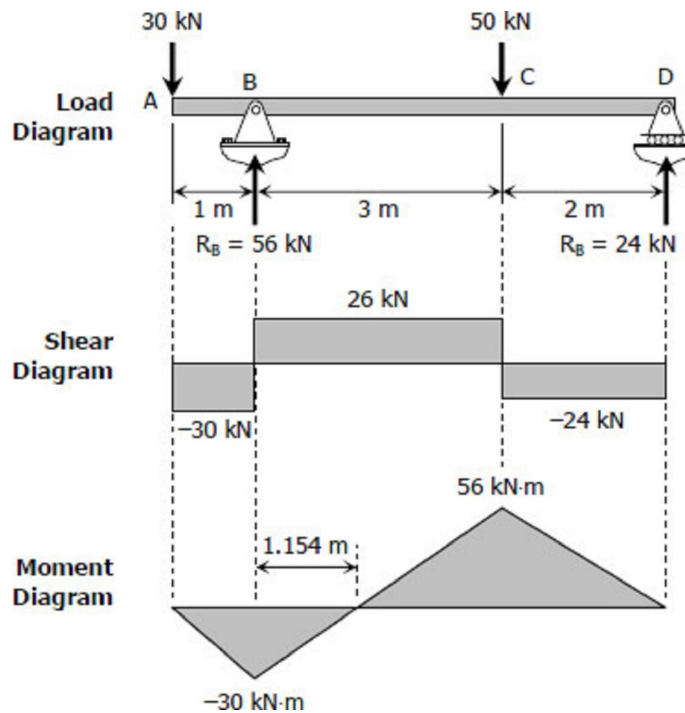

Solution to Problem 404 | Shear and Moment Diagrams

Beam loaded as shown in [Fig. P-404](#). See the [instruction](#).

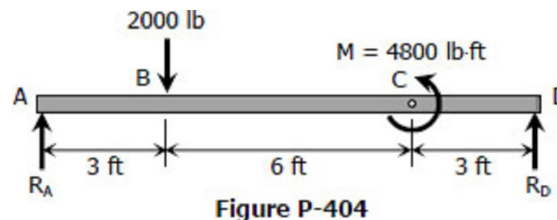

Solution 404

$$\Sigma M_A = 0$$

$$12R_D + 4800 = 3(2000)$$

$$R_D = 100 \text{ lb}$$

$$\Sigma M_D = 0$$

$$12R_A = 9(2000) + 4800$$

$$R_A = 1900 \text{ lb}$$

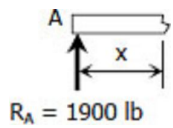

Segment AB:

$$V_{AB} = 1900 \text{ lb}$$

$$M_{AB} = 1900x \text{ lb} \cdot \text{ft}$$

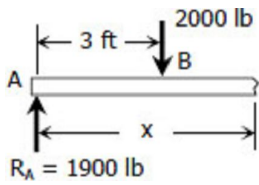

Segment BC:

$$V_{BC} = 1900 - 2000$$

$$V_{BC} = -100 \text{ lb}$$

$$M_{BC} = 1900x - 2000(x - 3)$$

$$M_{BC} = 1900x - 2000x + 6000$$

$$M_{BC} = -100x + 6000 \text{ lb} \cdot \text{ft}$$

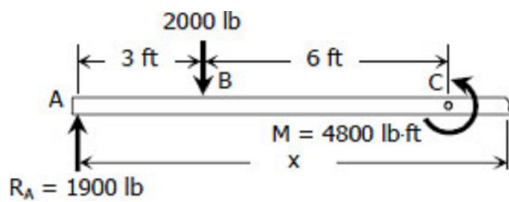

Segment CD:

$$V_{CD} = 1900 - 2000$$

$$V_{CD} = -100 \text{ lb}$$

$$M_{CD} = 1900x - 2000(x - 3) - 4800$$

$$M_{CD} = 1900x - 2000x + 6000 - 4800$$

$$M_{CD} = -100x + 1200 \text{ lb} \cdot \text{ft}$$

To draw the Shear Diagram:

1. At segment AB, the shear is uniformly distributed at 1900 lb.
2. A shear of -100 lb is uniformly distributed over segments BC and CD.

To draw the Moment Diagram:

1. $M_{AB} = 1900x$ is linear; at $x = 0$,

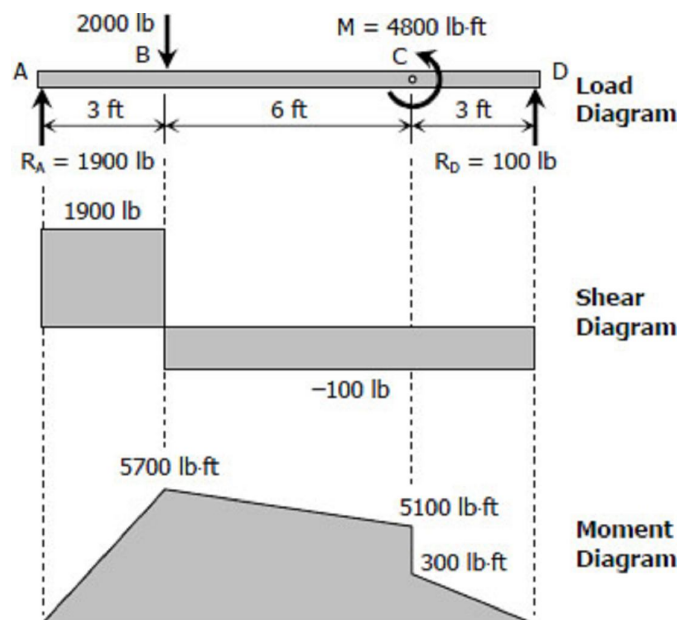

- $M_{AB} = 0$; at $x = 3$ ft, $M_{AB} = 5700$ lb·ft.
- For segment BC, $M_{BC} = -100x + 6000$ is linear; at $x = 3$ ft, $M_{BC} = 5700$ lb·ft; at $x = 9$ ft, $M_{BC} = 5100$ lb·ft.
 - $M_{CD} = -100x + 1200$ is again linear; at $x = 9$ ft, $M_{CD} = 300$ lb·ft; at $x = 12$ ft, $M_{CD} = 0$.

Solution to Problem 405 | Shear and Moment Diagrams

Beam loaded as shown in [Fig. P-405](#). See the [instruction](#).

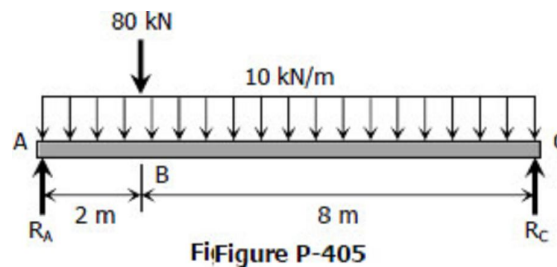

Solution 405

$$\begin{aligned}\sum M_A &= 0 \\ 10R_C &= 2(80) + 5[10(10)] \\ R_C &= 66 \text{ kN}\end{aligned}$$

$$\begin{aligned}\sum M_C &= 0 \\ 10R_A &= 8(80) + 5[10(10)] \\ R_A &= 114 \text{ kN}\end{aligned}$$

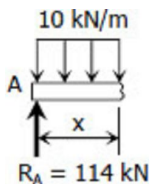

Segment AB:

$$\begin{aligned}V_{AB} &= 114 - 10x \text{ kN} \\ M_{AB} &= 114x - 10x(x/2) \\ M_{AB} &= 114x - 5x^2 \text{ kN} \cdot \text{m}\end{aligned}$$

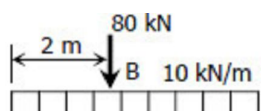

Segment BC:

$$V_{BC} = 114 - 80 - 10x$$

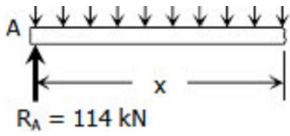

$$V_{BC} = 34 - 10x \text{ kN}$$

$$M_{BC} = 114x - 80(x-2) - 10x(x/2)$$

$$M_{BC} = 160 + 34x - 5x^2 \text{ kN} \cdot \text{m}$$

To draw the Shear Diagram:

1. For segment AB, $V_{AB} = 114 - 10x$ is linear; at $x = 0$, $V_{AB} = 114$ kN; at $x = 2$ m, $V_{AB} = 94$ kN.
2. $V_{BC} = 34 - 10x$ for segment BC is linear; at $x = 2$ m, $V_{BC} = 14$ kN; at $x = 10$ m, $V_{BC} = -66$ kN. When $V_{BC} = 0$, $x = 3.4$ m thus $V_{BC} = 0$ at 1.4 m from B.
- 3.

To draw the Moment Diagram:

1. $M_{AB} = 114x - 5x^2$ is a second degree curve for segment AB; at $x = 0$, $M_{AB} = 0$; at $x = 2$ m, $M_{AB} = 208$ kN·m.
2. The moment diagram is also a second degree curve for segment BC given by $M_{BC} = 160 + 34x - 5x^2$; at $x = 2$ m, $M_{BC} = 208$ kN·m; at $x = 10$ m, $M_{BC} = 0$.
3. Note that the maximum moment occurs at point of zero shear. Thus, at $x = 3.4$ m, $M_{BC} = 217.8$ kN·m.

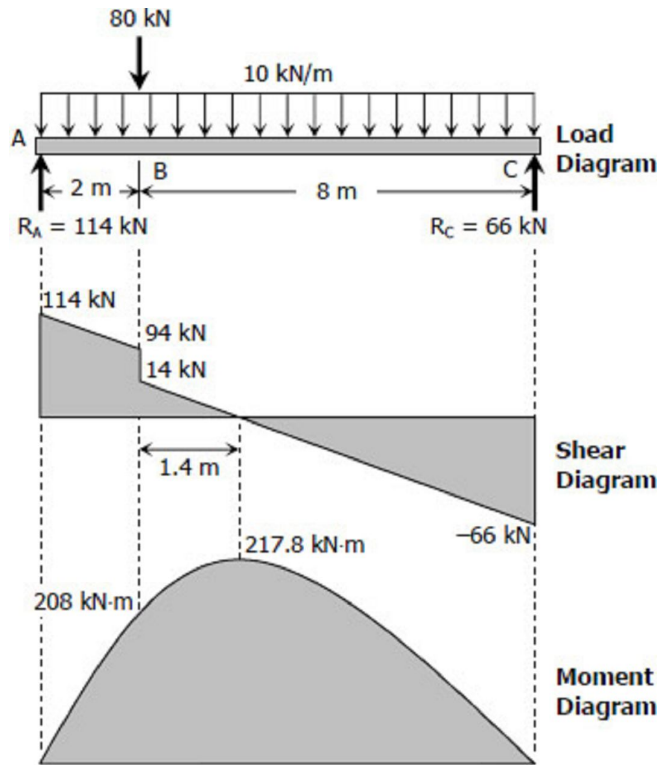

Solution to Problem 406 | Shear and Moment Diagrams

Beam loaded as shown in [Fig. P-406](#). See the [instruction](#).

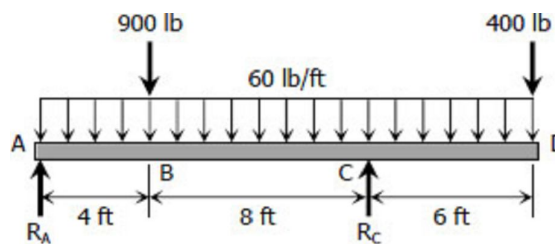

Figure P-406

Solution 406

$$\Sigma M_A = 0$$

$$12R_C = 4(900) + 18(400) + 9[(60)(18)]$$

$$R_C = 1710 \text{ lb}$$

$$\Sigma M_C = 0$$

$$12R_A + 6(400) = 8(900) + 3[60(18)]$$

$$R_A = 670 \text{ lb}$$

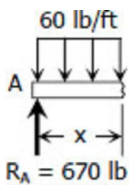

Segment AB:

$$V_{AB} = 670 - 60x \text{ lb}$$

$$M_{AB} = 670x - 60x(x/2)$$

$$M_{AB} = 670x - 30x^2 \text{ lb} \cdot \text{ft}$$

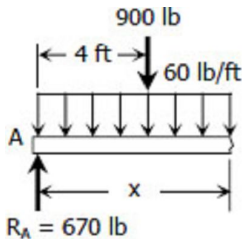

Segment BC:

$$V_{BC} = 670 - 900 - 60x$$

$$V_{BC} = -230 - 60x \text{ lb}$$

$$M_{BC} = 670x - 900(x-4) - 60x(x/2)$$

$$M_{BC} = 3600 - 230x - 30x^2 \text{ lb} \cdot \text{ft}$$

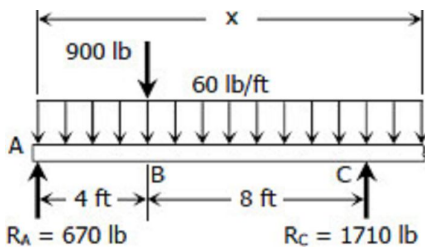

Segment CD:

$$V_{CD} = 670 + 1710 - 900 - 60x$$

$$V_{CD} = 1480 - 60x \text{ lb}$$

$$M_{CD} = 670x + 1710(x-12) - 900(x-4) - 60x(x/2)$$

$$M_{CD} = -16920 + 1480x - 30x^2 \text{ lb} \cdot \text{ft}$$

To draw the Shear Diagram:

1. $V_{AB} = 670 - 60x$ for segment AB is linear; at $x = 0$, $V_{AB} = 670 \text{ lb}$; at $x = 4 \text{ ft}$, $V_{AB} = 430 \text{ lb}$.
2. For segment BC, $V_{BC} = -230 - 60x$ is also linear; at $x = 4 \text{ ft}$, $V_{BC} = -470 \text{ lb}$, at $x = 12 \text{ ft}$, $V_{BC} = -950 \text{ lb}$.
3. $V_{CD} = 1480 - 60x$ for segment CD is

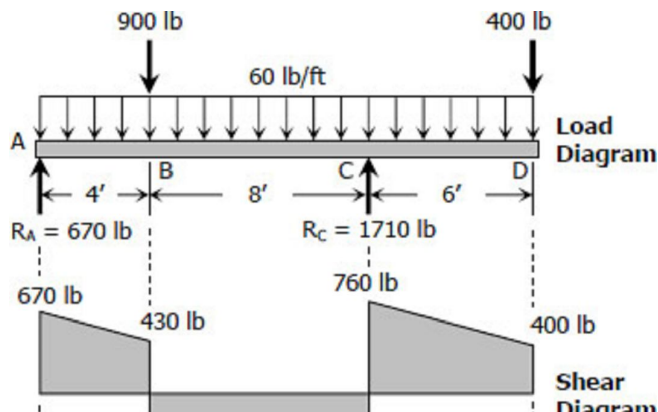

again linear; at $x = 12$, $V_{CD} = 760$ lb;
at $x = 18$ ft, $V_{CD} = 400$ lb.

To draw the Moment Diagram:

1. $M_{AB} = 670x - 30x^2$ for segment AB is a second degree curve; at $x = 0$, $M_{AB} = 0$; at $x = 4$ ft, $M_{AB} = 2200$ lb·ft.
2. For BC, $M_{BC} = 3600 - 230x - 30x^2$, is a second degree curve; at $x = 4$ ft, $M_{BC} = 2200$ lb·ft, at $x = 12$ ft, $M_{BC} = -3480$ lb·ft; When $M_{BC} = 0$, $3600 - 230x - 30x^2 = 0$, $x = -15.439$ ft and 7.772 ft. Take $x = 7.772$ ft, thus, the moment is zero at 3.772 ft from B.
3. For segment CD, $M_{CD} = -16920 + 1480x - 30x^2$ is a second degree curve; at $x = 12$ ft, $M_{CD} = -3480$ lb·ft; at $x = 18$ ft, $M_{CD} = 0$.

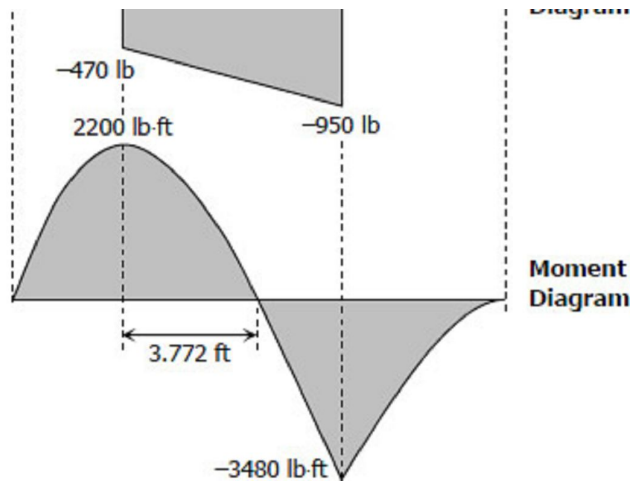

Solution to Problem 407 | Shear and Moment Diagrams

Beam loaded as shown in [Fig. P-407](#). See the [instruction](#).

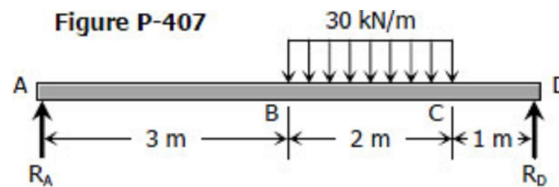

Solution 407

$$\begin{aligned} \Sigma M_A &= 0 \\ 6R_D &= 4[2(30)] \\ R_D &= 40 \text{ kN} \end{aligned}$$

$$\begin{aligned} \Sigma M_D &= 0 \\ 6R_A &= 2[2(30)] \\ R_A &= 20 \text{ kN} \end{aligned}$$

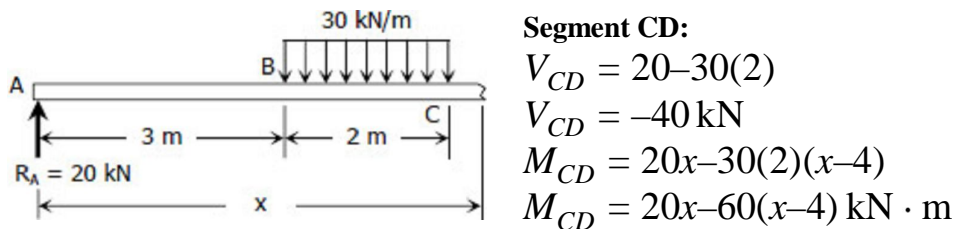
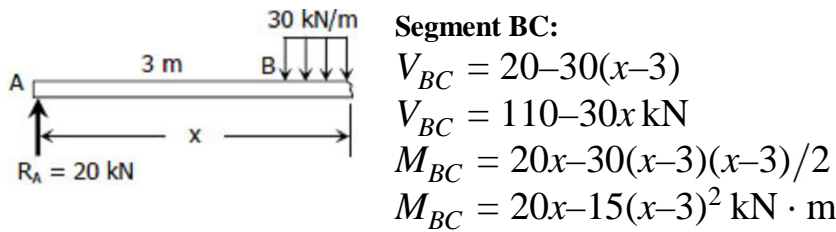
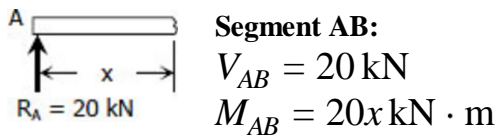

To draw the Shear Diagram:

1. For segment AB, the shear is uniformly distributed at 20 kN.
2. $V_{BC} = 110 - 30x$ for segment BC; at $x = 3 \text{ m}$, $V_{BC} = 20 \text{ kN}$; at $x = 5 \text{ m}$, $V_{BC} = -40 \text{ kN}$. For $V_{BC} = 0$, $x = 3.67 \text{ m}$ or 0.67 m from B.
3. The shear for segment CD is uniformly distributed at -40 kN.

To draw the Moment Diagram:

1. For AB, $M_{AB} = 20x$; at $x = 0$, $M_{AB} = 0$; at $x = 3 \text{ m}$, $M_{AB} = 60 \text{ kN} \cdot \text{m}$.
2. $M_{BC} = 20x - 15(x - 3)^2$ for segment BC is second degree curve; at $x = 3 \text{ m}$, $M_{BC} = 60 \text{ kN} \cdot \text{m}$; at $x = 5 \text{ m}$, $M_{BC} = 40 \text{ kN} \cdot \text{m}$. **Note:** that maximum moment occurred at zero shear; at $x = 3.67 \text{ m}$, $M_{BC} = 66.67 \text{ kN} \cdot \text{m}$.
3. $M_{CD} = 20x - 60(x - 4)$ for segment BC is linear; at $x = 5 \text{ m}$, $M_{CD} = 40 \text{ kN} \cdot \text{m}$; at $x = 6 \text{ m}$, $M_{CD} = 0$.

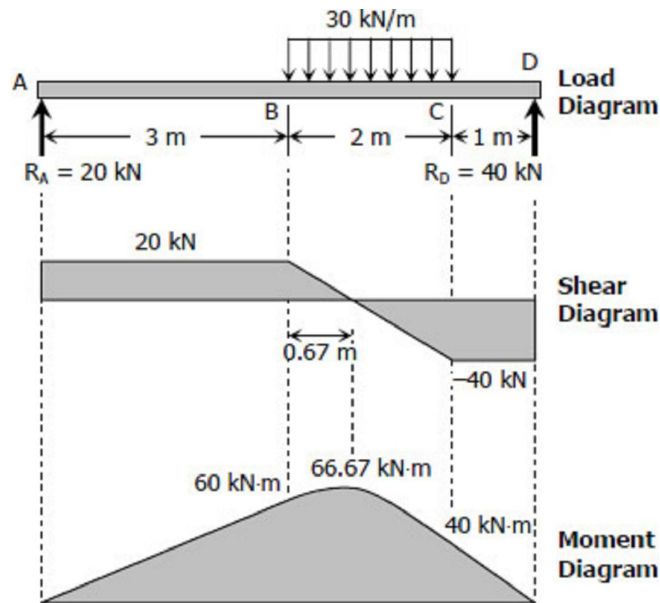

Solution to Problem 408 | Shear and Moment Diagrams

Beam loaded as shown in [Fig. P-408](#). See the [instruction](#).

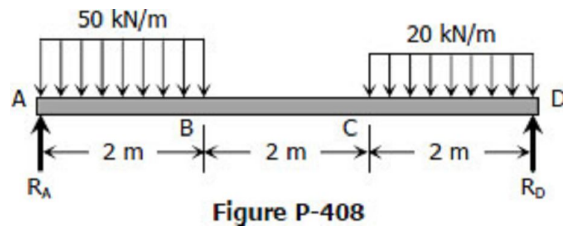

Solution 408

$$\sum M_A = 0$$

$$6R_D = 1[2(50)] + 5[2(20)]$$

$$R_D = 50 \text{ kN}$$

$$\sum M_D = 0$$

$$6R_A = 5[2(50)] + 1[2(20)]$$

$$R_A = 90 \text{ kN}$$

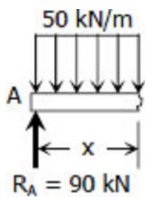

Segment AB:

$$V_{AB} = 90 - 50x \text{ kN}$$

$$M_{AB} = 90x - 50x(x/2)$$

$$M_{AB} = 90x - 25x^2 \text{ kN} \cdot \text{m}$$

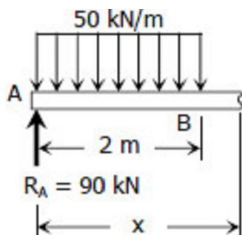

Segment BC:

$$V_{BC} = 90 - 50(2)$$

$$V_{BC} = -10 \text{ kN}$$

$$M_{BC} = 90x - 2(50)(x-1)$$

$$M_{BC} = -10x + 100 \text{ kN} \cdot \text{m}$$

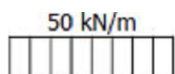

Segment CD:

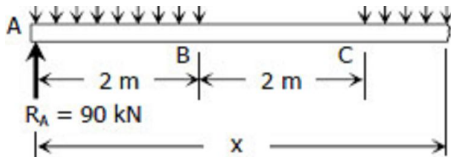

$$V_{CD} = 90 - 2(50) - 20(x-4)$$

$$V_{CD} = -20x + 70 \text{ kN}$$

$$M_{CD} = 90x - 2(50)(x-1) - 20(x-4)(x-4)/2$$

$$M_{CD} = 90x - 100(x-1) - 10(x-4)^2$$

$$M_{CD} = -10x^2 + 70x - 60 \text{ kN} \cdot \text{m}$$

To draw the Shear Diagram:

- $V_{AB} = 90 - 50x$ is linear; at $x = 0$, $V_{BC} = 90 \text{ kN}$; at $x = 2 \text{ m}$, $V_{BC} = -10 \text{ kN}$.
When $V_{AB} = 0$, $x = 1.8 \text{ m}$.
- $V_{BC} = -10 \text{ kN}$ along segment BC.
- $V_{CD} = -20x + 70$ is linear; at $x = 4 \text{ m}$, $V_{CD} = -10 \text{ kN}$; at $x = 6 \text{ m}$, $V_{CD} = -50 \text{ kN}$.

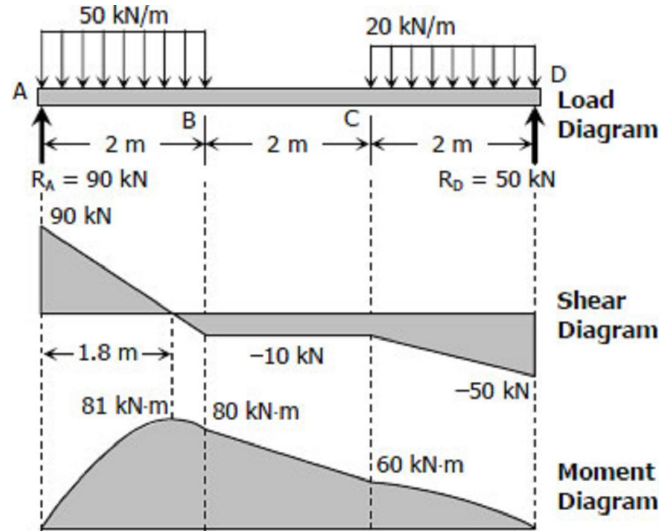

To draw the Moment Diagram:

- $M_{AB} = 90x - 25x^2$ is second degree; at $x = 0$, $M_{AB} = 0$; at $x = 1.8 \text{ m}$, $M_{AB} = 81 \text{ kN}\cdot\text{m}$; at $x = 2 \text{ m}$, $M_{AB} = 80 \text{ kN}\cdot\text{m}$.
- $M_{BC} = -10x + 100$ is linear; at $x = 2 \text{ m}$, $M_{BC} = 80 \text{ kN}\cdot\text{m}$; at $x = 4 \text{ m}$, $M_{BC} = 60 \text{ kN}\cdot\text{m}$.
- $M_{CD} = -10x^2 + 70x - 60$; at $x = 4 \text{ m}$, $M_{CD} = 60 \text{ kN}\cdot\text{m}$; at $x = 6 \text{ m}$, $M_{CD} = 0$.

Solution to Problem 409 | Shear and Moment Diagrams

Cantilever beam loaded as shown in [Fig. P-409](#). See the [instruction](#).

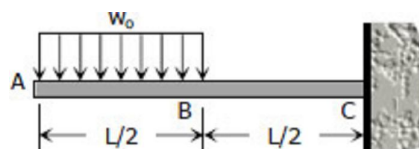
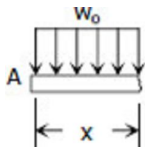

Figure P-409

Solution 409



Segment AB:

$$V_{AB} = -w_0x$$

$$M_{AB} = -w_0x(x/2)$$

$$M_{AB} = -\frac{1}{2}w_0x^2$$

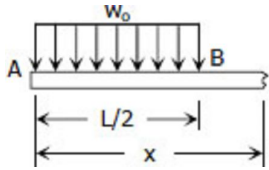

Segment BC:

$$V_{BC} = -w_0(L/2)$$

$$V_{BC} = -\frac{1}{2}w_0L$$

$$M_{BC} = -w_0(L/2)(x-L/4)$$

$$M_{BC} = -\frac{1}{2}w_0Lx + \frac{1}{8}w_0L^2$$

To draw the Shear Diagram:

1. $V_{AB} = -w_0x$ for segment AB is linear; at $x = 0$, $V_{AB} = 0$; at $x = L/2$, $V_{AB} = -\frac{1}{2}w_0L$.
2. At BC, the shear is uniformly distributed by $-\frac{1}{2}w_0L$.

To draw the Moment Diagram:

1. $M_{AB} = -\frac{1}{2}w_0x^2$ is a second degree curve; at $x = 0$, $M_{AB} = 0$; at $x = L/2$, $M_{AB} = -\frac{1}{8}w_0L^2$.
2. $M_{BC} = -\frac{1}{2}w_0Lx + \frac{1}{8}w_0L^2$ is a second degree; at $x = L/2$, $M_{BC} = -\frac{1}{8}w_0L^2$; at $x = L$, $M_{BC} = -\frac{3}{8}w_0L^2$.

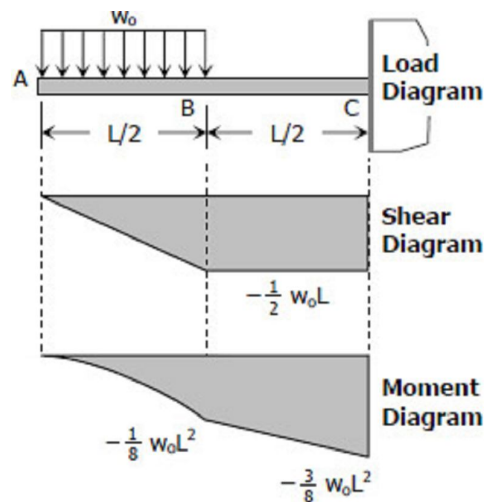

Solution to Problem 410 | Shear and Moment Diagrams

Cantilever beam carrying the uniformly varying load shown in [Fig. P-410](#). See the [instruction](#).

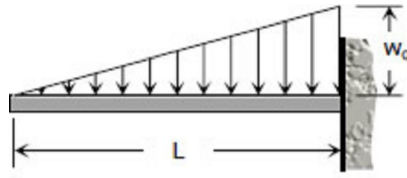

Figure P-410

Solution 410

$$\frac{y}{x} = \frac{w_0}{L}$$

$$y = \frac{w_0}{L} x$$

$$F_x = \frac{1}{2}xy$$

$$F_x = \frac{1}{2}x \left(\frac{w_0}{L} x \right)$$

$$F_x = \frac{w_0}{2L} x^2$$

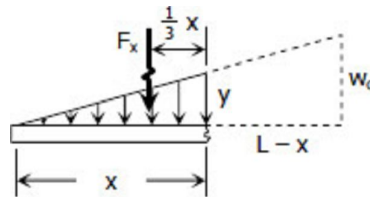

Shear equation:

$$V = -\frac{w_0}{2L} x^2$$

Moment equation:

$$M = -\frac{1}{3}xF_x = -\frac{1}{3}x \left(\frac{w_0}{2L} x^2 \right)$$

$$M = -\frac{w_0}{6L} x^3$$

To draw the Shear Diagram:

1. $V = -w_0 x^2 / 2L$ is a second degree curve; at $x = 0$, $V = 0$; at $x = L$, $V = -1/2 w_0 L$.

To draw the Moment Diagram:

1. $M = -w_0 x^3 / 6L$ is a third degree curve; at $x = 0$, $M = 0$; at $x = L$, $M = -1/6 w_0 L^2$.

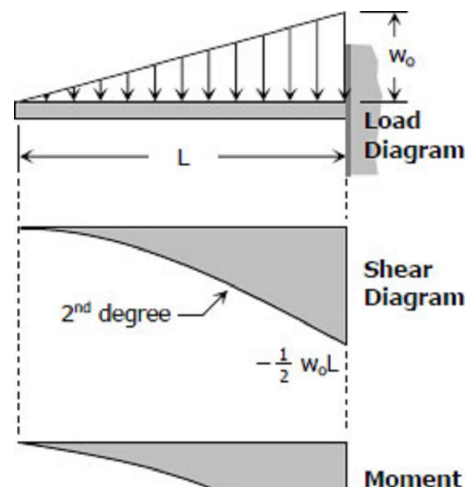

Solution to Problem 411 | Shear and Moment Diagrams

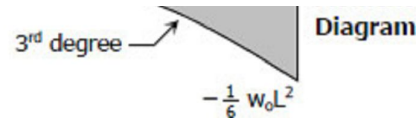

Cantilever beam carrying a distributed load with intensity varying from w_0 at the free end to zero at the wall, as shown in [Fig. P-411](#). See the [instruction](#).

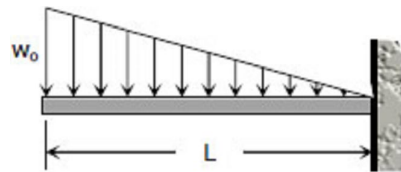

Figure P-411

Solution 411

$$\frac{y}{L-x} = \frac{w_0}{L}$$

$$y = \frac{w_0}{L} (L-x)$$

$$F_1 \frac{1}{2} x (w_0 - y)$$

$$F_1 = \frac{1}{2} x \left[w_0 - \frac{w_0}{L} (L-x) \right]$$

$$F_1 = \frac{1}{2} x \left[w_0 - w_0 \frac{L-x}{L} \right]$$

$$F_1 = \frac{w_0}{2L} x^2$$

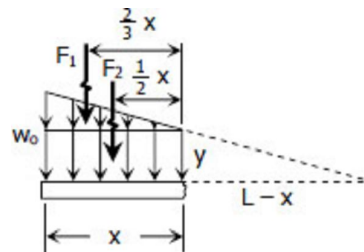

$$F_2 = xy = x \left[\frac{w_0}{L} (L-x) \right]$$

$$F_2 = \frac{w_0}{L} (Lx - x^2)$$

Shear equation:

$$V = -F_1 - F_2 = -\frac{w_0}{2L}x^2 - \frac{w_0}{L}(Lx - x^2)$$

$$V = -\frac{w_0}{2L}x^2 - w_0x + \frac{w_0}{L}x^2$$

$$V = \frac{w_0}{2L}x^2 - w_0x$$

Moment equation:

$$M = -\frac{2}{3}xF_1 - \frac{1}{2}xF_2$$

$$M = -\frac{2}{3}x \left(\frac{w_0}{2L}x^2 \right) - \frac{1}{2}x \left[\frac{w_0}{L}(Lx - x^2) \right]$$

$$M = -\frac{w_0}{3L}x^3 - \frac{w_0}{2}x^2 + \frac{w_0}{2L}x^3$$

$$M = -\frac{w_0}{2}x^2 + \frac{w_0}{6L}x^3$$

To draw the Shear Diagram:

1. $V = w_0x^2/2L - w_0x$ is a concave upward second degree curve; at $x = 0$, $V = 0$; at $x = L$, $V = -1/2 w_0L$.

To draw the Moment diagram:

1. $M = -w_0x^2/2 + w_0x^3/6L$ is in third degree; at $x = 0$, $M = 0$; at $x = L$, $M = -1/3 w_0L^2$.

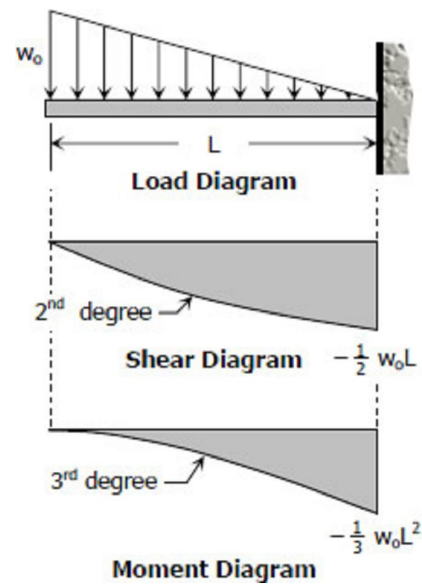

Solution to Problem 412 | Shear and Moment Diagrams

Beam loaded as shown in [Fig. P-412](#). See the [instruction](#).

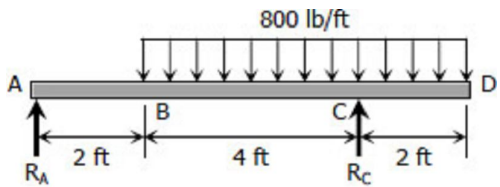

Figure P-412

Solution 412

$$\Sigma M_A = 0$$

$$6R_C = 5 [6(800)]$$

$$R_C = 4000 \text{ lb}$$

$$\Sigma M_C = 0$$

$$6R_A = 1 [6(800)]$$

$$R_A = 800 \text{ lb}$$

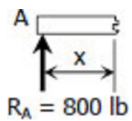

Segment AB:

$$V_{AB} = 800 \text{ lb}$$

$$M_{AB} = 800x \text{ lb} \cdot \text{ft}$$

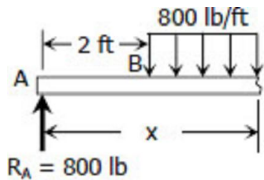

Segment BC:

$$V_{BC} = 800 - 800(x-2)$$

$$V_{BC} = 2400 - 800x \text{ lb}$$

$$M_{BC} = 800x - 800(x-2)(x-2)/2$$

$$M_{BC} = 800x - 400(x-2)^2 \text{ lb} \cdot \text{ft}$$

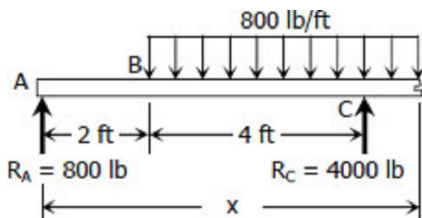

Segment CD:

$$V_{CD} = 800 + 4000 - 800(x-2)$$

$$V_{CD} = 4800 - 800x + 1600$$

$$V_{CD} = 6400 - 800x \text{ lb}$$

$$M_{CD} = 800x + 4000(x-6) - 800(x-2)(x-2)/2$$

$$M_{CD} = 800x + 4000(x-6) - 400(x-2)^2 \text{ lb} \cdot \text{ft}$$

To draw the Shear Diagram:

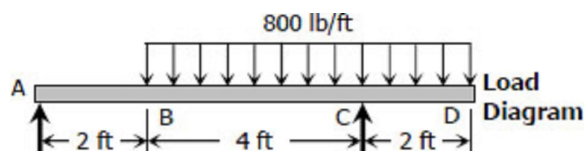

1. 800 lb of shear force is uniformly distributed along segment AB.
2. $V_{BC} = 2400 - 800x$ is linear; at $x = 2$ ft, $V_{BC} = 800$ lb; at $x = 6$ ft, $V_{BC} = -2400$ lb. When $V_{BC} = 0$, $2400 - 800x = 0$, thus $x = 3$ ft or $V_{BC} = 0$ at 1 ft from B.
3. $V_{CD} = 6400 - 800x$ is also linear; at $x = 6$ ft, $V_{CD} = 1600$ lb; at $x = 8$ ft, $V_{CD} = 0$.

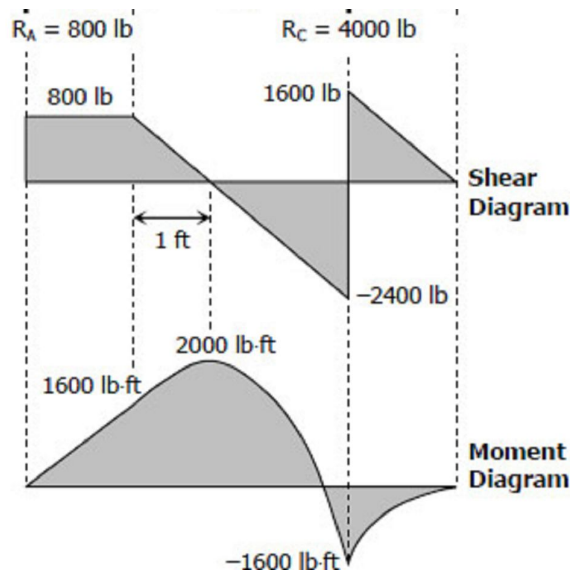

To draw the Moment Diagram:

1. $M_{AB} = 800x$ is linear; at $x = 0$, $M_{AB} = 0$; at $x = 2$ ft, $M_{AB} = 1600$ lb-ft.
2. $M_{BC} = 800x - 400(x - 2)^2$ is second degree curve; at $x = 2$ ft, $M_{BC} = 1600$ lb-ft; at $x = 6$ ft, $M_{BC} = -1600$ lb-ft; at $x = 3$ ft, $M_{BC} = 2000$ lb-ft.
3. $M_{CD} = 800x + 4000(x - 6) - 400(x - 2)^2$ is also a second degree curve; at $x = 6$ ft, $M_{CD} = -1600$ lb-ft; at $x = 8$ ft, $M_{CD} = 0$.

Solution to Problem 413 | Shear and Moment Diagrams

Beam loaded as shown in [Fig. P-413](#). See the [instruction](#).

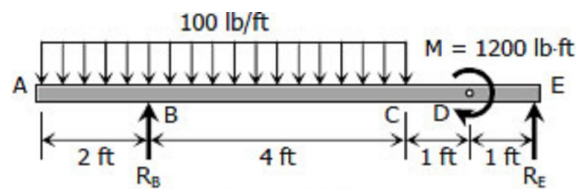

Figure P-413

Solution 413

$$\sum M_B = 0$$

$$6R_E = 1200 + 1 [6(100)]$$

$$R_E = 300 \text{ lb}$$

$$\sum M_E = 0$$

$$6R_B + 1200 = 5 [6(100)]$$

$$R_B = 300 \text{ lb}$$

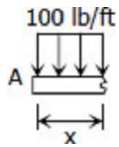

Segment AB:

$$V_{AB} = -100x \text{ lb}$$

$$M_{AB} = -100x(x/2)$$

$$M_{AB} = -50x^2 \text{ lb} \cdot \text{ft}$$

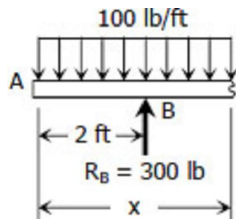

Segment BC:

$$V_{BC} = -100x + 300 \text{ lb}$$

$$M_{BC} = -100x(x/2) + 300(x-2)$$

$$M_{BC} = -50x^2 + 300x - 600 \text{ lb} \cdot \text{ft}$$

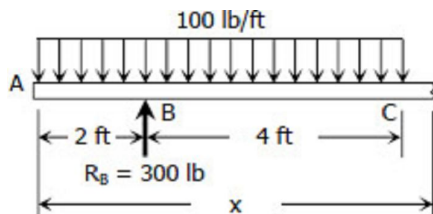

Segment CD:

$$V_{CD} = -100(6) + 300$$

$$V_{CD} = -300 \text{ lb}$$

$$M_{CD} = -100(6)(x-3) + 300(x-2)$$

$$M_{CD} = -600x + 1800 + 300x - 600$$

$$M_{CD} = -300x + 1200 \text{ lb} \cdot \text{ft}$$

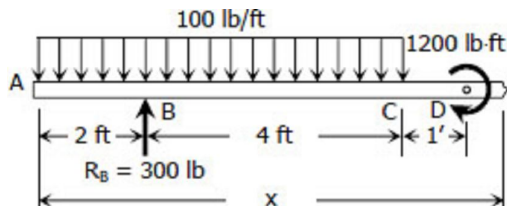

Segment DE:

$$V_{DE} = -100(6) + 300$$

$$V_{DE} = -300 \text{ lb}$$

$$M_{DE} = -100(6)(x-3) + 1200 + 300(x-2)$$

$$M_{DE} = -600x + 1800 + 1200 + 300x - 600$$

$$M_{DE} = -300x + 2400 \text{ lb} \cdot \text{ft}$$

To draw the Shear Diagram:

1. $V_{AB} = -100x$ is linear; at $x = 0$, $V_{AB} = 0$; at $x = 2$ ft, $V_{AB} = -200$ lb.
2. $V_{BC} = 300 - 100x$ is also linear; at $x = 2$ ft, $V_{BC} = 100$ lb; at $x = 4$ ft, $V_{BC} = -300$ lb. When $V_{BC} = 0$, $x = 3$ ft, or $V_{BC} = 0$ at 1 ft from B.
3. The shear is uniformly distributed at -300 lb along segments CD and DE.

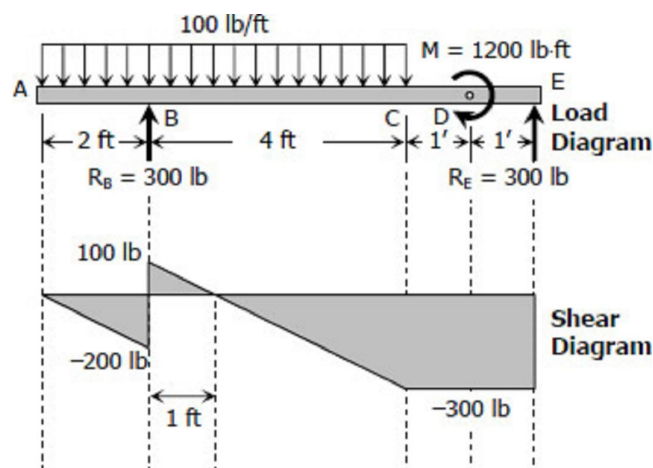

To draw the Moment Diagram:

1. $M_{AB} = -50x^2$ is a second degree curve; at $x = 0$, $M_{AB} = 0$; at $x = 6$ ft, $M_{AB} = -200$ lb-ft.
2. $M_{BC} = -50x^2 + 300x - 600$ is also second degree; at $x = 2$ ft, $M_{BC} = -200$ lb-ft; at $x = 6$ ft, $M_{BC} = -600$ lb-ft; at $x = 3$ ft, $M_{BC} = -150$ lb-ft.
3. $M_{CD} = -300x + 1200$ is linear; at $x = 6$ ft, $M_{CD} = -600$ lb-ft; at $x = 7$ ft, $M_{CD} = -900$ lb-ft.
4. $M_{DE} = -300x + 2400$ is again linear; at $x = 7$ ft, $M_{DE} = 300$ lb-ft; at $x = 8$ ft, $M_{DE} = 0$.

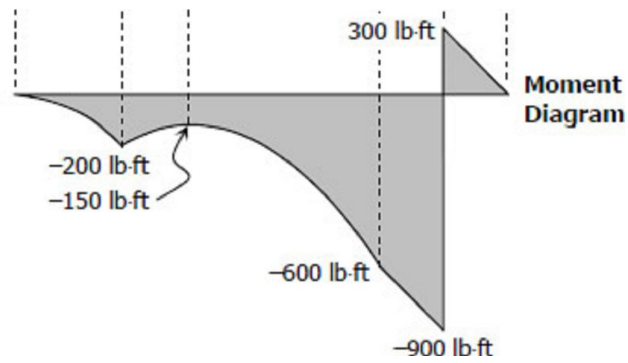

Solution to Problem 414 | Shear and Moment Diagrams

Cantilever beam carrying the load shown in [Fig. P-414](#). See the [instruction](#).

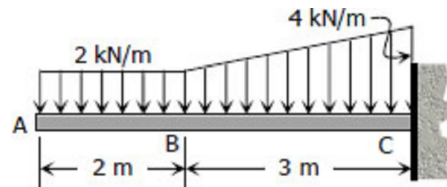
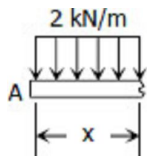

Figure P-414

Solution 414



Segment AB:

$$V_{AB} = -2x \text{ kN}$$

$$M_{AB} = -2x(x/2)$$

$$M_{AB} = -x^2 \text{ kN} \cdot \text{m}$$

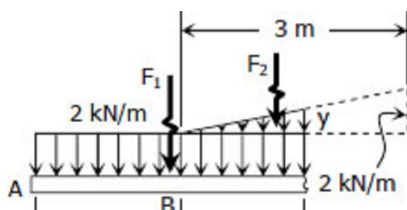

Segment BC:

$$\frac{y}{x-2} = \frac{2}{2}$$

$$y = \frac{2}{3}(x-2)$$

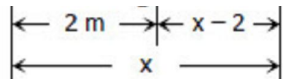

$$F_1 = 2x$$

$$F_2 = \frac{1}{2}(x-2)y$$

$$F_2 = \frac{1}{2}(x-2) \left[\frac{2}{3}(x-2) \right]$$

$$F_2 = \frac{1}{3}(x-2)^2$$

$$V_{BC} = -F_1 - F_2$$

$$V_{BC} = -2x - \frac{1}{3}(x-2)^2$$

$$M_{BC} = -(x/2)F_1 - \frac{1}{3}(x-2)F_2$$

$$M_{BC} = -(x/2)(2x) - \frac{1}{3}(x-2) \left[\frac{1}{3}(x-2)^2 \right]$$

$$M_{BC} = -x^2 - \frac{1}{9}(x-2)^3$$

To draw the Shear Diagram:

1. $V_{AB} = -2x$ is linear; at $x = 0$, $V_{AB} = 0$; at $x = 2$ m, $V_{AB} = -4$ kN.
2. $V_{BC} = -2x - \frac{1}{3}(x-2)^2$ is a second degree curve; at $x = 2$ m, $V_{BC} = -4$ kN; at $x = 5$ m, $V_{BC} = -13$ kN.

To draw the Moment Diagram:

1. $M_{AB} = -x^2$ is a second degree curve; at $x = 0$, $M_{AB} = 0$; at $x = 2$ m, $M_{AB} = -4$ kN·m.
2. $M_{BC} = -x^2 - \frac{1}{9}(x-2)^3$ is a third degree curve; at $x = 2$ m, $M_{BC} = -4$ kN·m; at $x = 5$ m, $M_{BC} = -28$ kN·m.

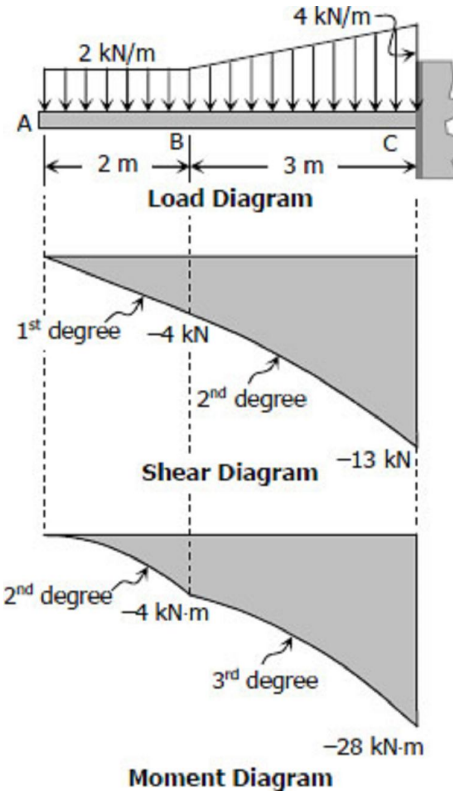

Solution to Problem 415 | Shear and Moment Diagrams

Cantilever beam loaded as shown in [Fig. P-415](#). See the [instruction](#).

Figure P-415

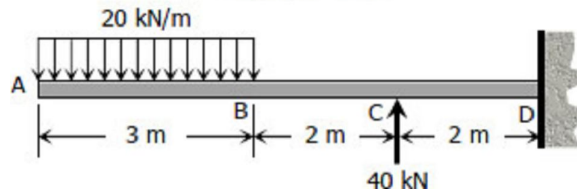

Solution 415

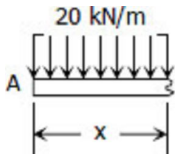

Segment AB:

$$V_{AB} = -20x \text{ kN}$$

$$M_{AB} = -20x(x/2)$$

$$M_{AB} = -10x^2 \text{ kN} \cdot \text{m}$$

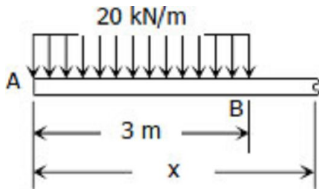

Segment BC:

$$V_{BC} = -20(3)$$

$$V_{AB} = -60 \text{ kN}$$

$$M_{BC} = -20(3)(x-1.5)$$

$$M_{AB} = -60(x-1.5) \text{ kN} \cdot \text{m}$$

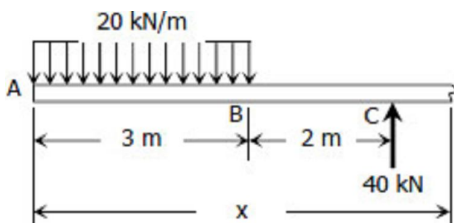

Segment CD:

$$V_{CD} = -20(3) + 40$$

$$V_{CD} = -20 \text{ kN}$$

$$M_{CD} = -20(3)(x-1.5) + 40(x-5)$$

$$M_{CD} = -60(x-1.5) + 40(x-5) \text{ kN} \cdot \text{m}$$

To draw the Shear Diagram

1. $V_{AB} = -20x$ for segment AB is linear; at $x = 0$, $V = 0$; at $x = 3 \text{ m}$, $V = -60 \text{ kN}$.
2. $V_{BC} = -60 \text{ kN}$ is uniformly distributed along segment BC.
3. Shear is uniform along segment CD at -20 kN .

To draw the Moment Diagram

1. $M_{AB} = -10x^2$ for segment AB is second degree curve; at $x = 0$, $M_{AB} = 0$; at $x = 3 \text{ m}$,

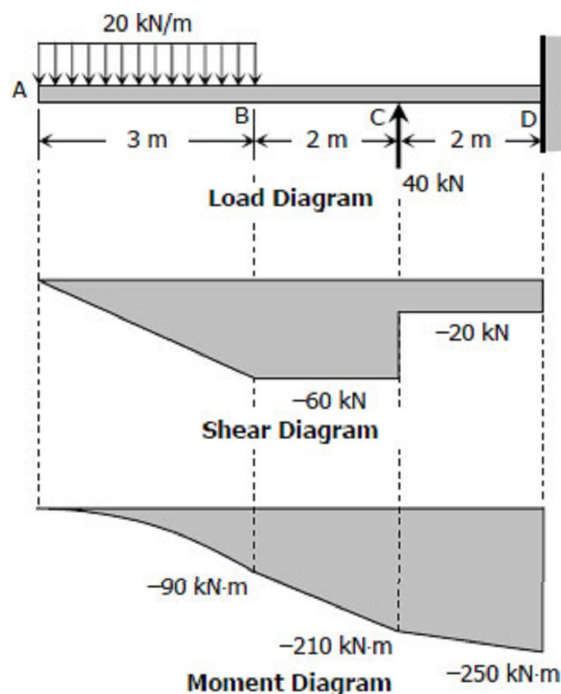

$$M_{AB} = -90 \text{ kN}\cdot\text{m}.$$

2. $M_{BC} = -60(x - 1.5)$ for segment BC is linear;
 at $x = 3 \text{ m}$, $M_{BC} = -90 \text{ kN}\cdot\text{m}$; at $x = 5 \text{ m}$,
 $M_{BC} = -210 \text{ kN}\cdot\text{m}$.

3. $M_{CD} = -60(x - 1.5) + 40(x - 5)$ for segment CD is also linear; at $x = 5 \text{ m}$, $M_{CD} = -210 \text{ kN}\cdot\text{m}$, at $x = 7 \text{ m}$, $M_{CD} = -250 \text{ kN}\cdot\text{m}$.

Solution to Problem 416 | Shear and Moment Diagrams

Beam carrying uniformly varying load shown in [Fig. P-416](#). See the [instruction](#).

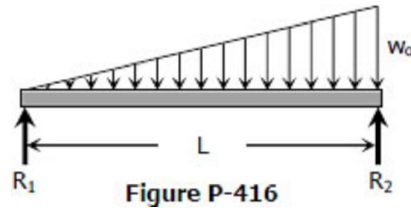

Solution 416

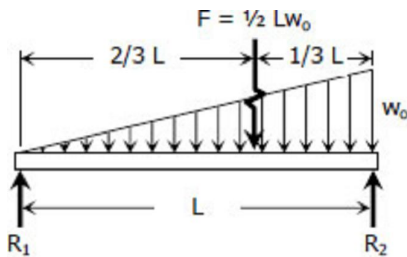

$$\Sigma M_{R_2} = 0$$

$$LR_1 = \frac{1}{3}LF$$

$$R_1 = \frac{1}{3} \left(\frac{1}{2}Lw_0 \right)$$

$$R_1 = \frac{1}{6}Lw_0$$

$$\Sigma M_{R_1} = 0$$

$$LR_2 = \frac{2}{3}LF$$

$$R_2 = \frac{2}{3} \left(\frac{1}{2}Lw_0 \right)$$

$$R_2 = \frac{1}{3}Lw_0$$

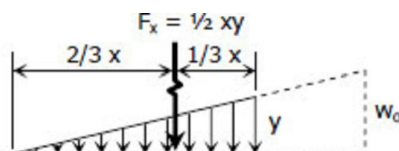

$$\frac{y}{x} = \frac{w_0}{L}$$

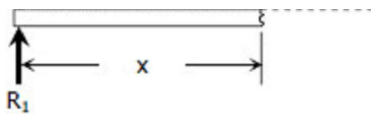

$$y = \frac{w_0}{L} x$$

$$F_x = \frac{1}{2}xy = \frac{1}{2}x \left(\frac{w_0}{L} x \right)$$

$$F_x = \frac{w_0}{2L} x^2$$

$$V = R_1 - F_x$$

$$V = \frac{1}{6}Lw_0 - \frac{w_0}{2L} x^2$$

$$M = R_1x - F_x \left(\frac{1}{3}x \right)$$

$$M = \frac{1}{6}Lw_0x - \frac{w_0}{2L} x^2 \left(\frac{1}{3}x \right)$$

$$M = \frac{1}{6}Lw_0x - \frac{w_0}{6L} x^3$$

To draw the Shear Diagram:

$V = 1/6 Lw_0 - w_0x^2/2L$ is a second degree curve; at $x = 0$, $V = 1/6 Lw_0 = R_1$; at $x = L$, $V = -1/3 Lw_0 = -R_2$; If a is the location of zero shear from left end, $0 = 1/6 Lw_0 - w_0x^2/2L$, $x = 0.5774L = a$; to check, use the squared property of parabola:

$$a^2/R_1 = L^2/(R_1 + R_2)$$

$$a^2/(1/6 Lw_0) = L^2/(1/6 Lw_0 + 1/3 Lw_0)$$

$$a^2 = (1/6 L^3w_0)/(1/2 Lw_0) = 1/3 L^2$$

$$a = 0.5774L$$

To draw the Moment Diagram:

$M = 1/6 Lw_0x - w_0x^3/6L$ is a third degree curve; at $x = 0$, $M = 0$; at $x = L$, $M = 0$; at $x = a = 0.5774L$, $M = M_{max}$.

$$M_{max} = 1/6 Lw_0(0.5774L) - w_0(0.5774L)^3/6L$$

$$M_{max} = 0.0962L^2w_0 - 0.0321L^2w_0$$

$$M_{max} = 0.0641L^2w_0$$

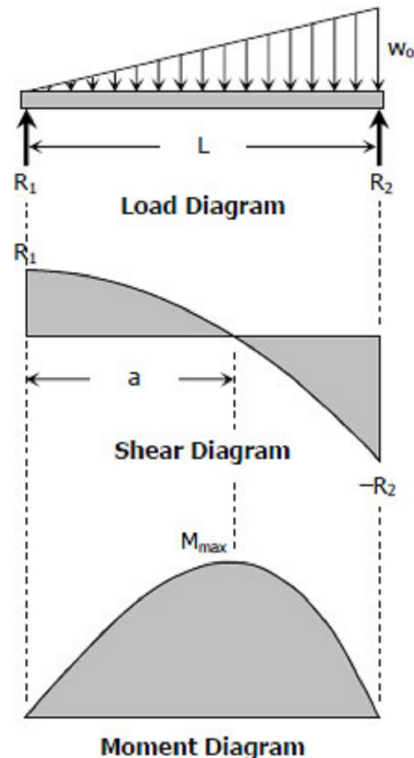

Solution to Problem 417 | Shear and Moment

Diagrams

Beam carrying the triangular loading shown in [Fig. P-417](#). See the [instruction](#).

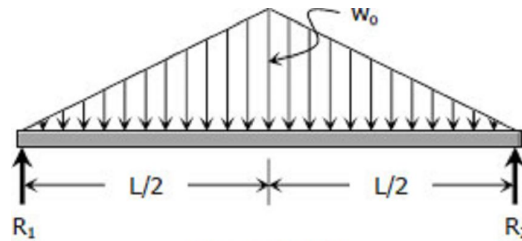
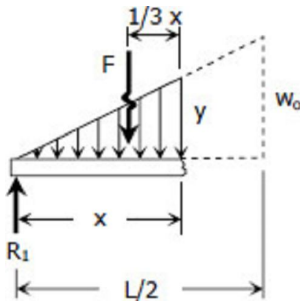

Figure P-417

Solution 417



By symmetry:

$$R_1 = R_2 = \frac{1}{2}(\frac{1}{2}Lw_0) = \frac{1}{4}Lw_0$$

$$\frac{y}{x} = \frac{w_0}{L/2}$$

$$y = \frac{2w_0}{L}x$$

$$F = \frac{1}{2}xy = \frac{1}{2}x \left(\frac{2w_0}{L}x \right)$$

$$F = \frac{w_0}{L}x^2$$

$$V = R_1 - F$$

$$V = \frac{1}{4}Lw_0 - \frac{w_0}{L}x^2$$

$$M = R_1x - F\left(\frac{1}{3}x\right)$$

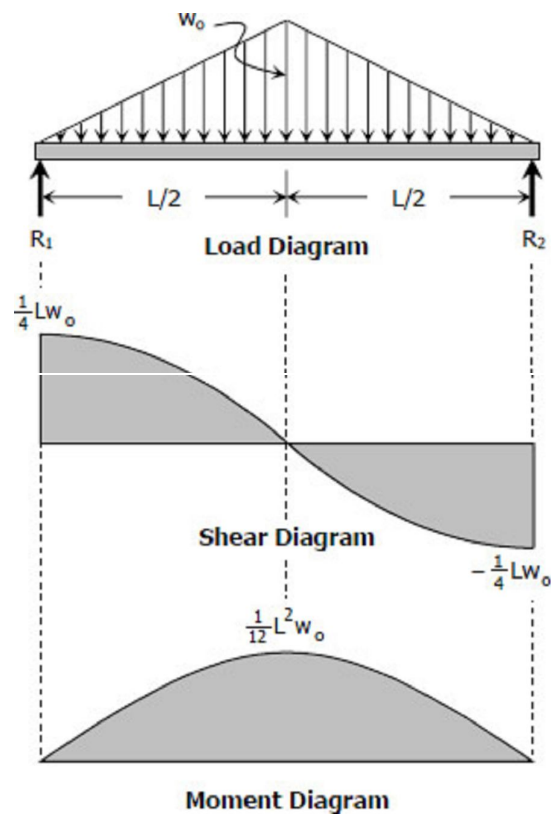

$$M = \frac{1}{4}Lw_0x - \left(\frac{w_0}{L}x^2\right)\left(\frac{1}{3}x\right)$$

To draw the Shear Diagram:

$V = Lw_0/4 - w_0x^2/L$ is a second degree curve; at $x = 0$, $V = Lw_0/4$; at $x = L/2$, $V = 0$. The other half of the diagram can be drawn by the concept of symmetry.

To draw the Moment Diagram

$M = Lw_0x/4 - w_0x^3/3L$ is a third degree curve; at $x = 0$, $M = 0$; at $x = L/2$, $M = L^2w_0/12$. The other half of the diagram can be drawn by the concept of symmetry.

Solution to Problem 418 | Shear and Moment Diagrams

Cantilever beam loaded as shown in [Fig. P-418](#). See the [instruction](#).

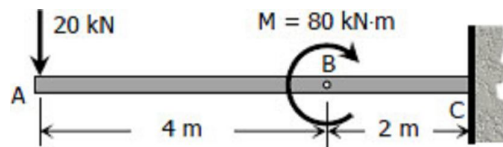
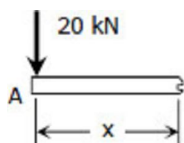

Figure P-418

Solution 418



Segment AB:

$$V_{AB} = -20 \text{ kN}$$

$$M_{AB} = -20x \text{ kN} \cdot \text{m}$$

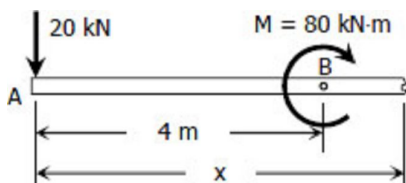

Segment BC:

$$V_{AB} = -20 \text{ kN}$$

$$M_{AB} = -20x + 80 \text{ kN} \cdot \text{m}$$

To draw the Shear Diagram:

1. V_{AB} and V_{BC} are equal and constant at -20 kN.

To draw the Moment Diagram:

1. $M_{AB} = -20x$ is linear; when $x = 0$, $M_{AB} = 0$; when $x = 4$ m, $M_{AB} = -80$ kN·m.
2. $M_{BC} = -20x + 80$ is also linear; when $x = 4$ m, $M_{BC} = 0$; when $x = 6$ m, $M_{BC} = -60$ kN·m

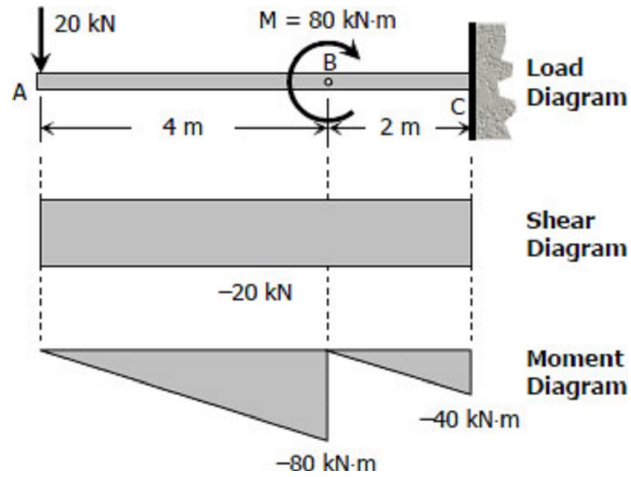

Solution to Problem 419 | Shear and Moment Diagrams

Beam loaded as shown in [Fig. P-419](#). See the [instruction](#).

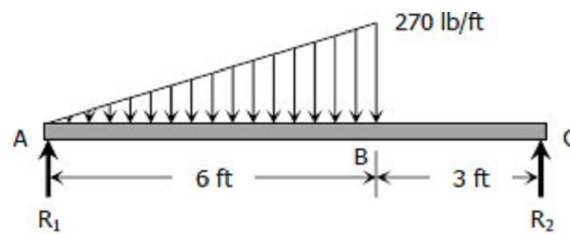
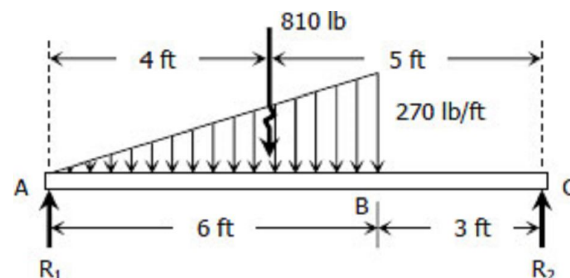

Figure P-419

Solution



$$\begin{aligned}\Sigma M_C &= 0 \\ 9R_1 &= 5(810) \\ R_1 &= 450 \text{ lb}\end{aligned}$$

$$\begin{aligned}\Sigma M_A &= 0 \\ 9R_2 &= 4(810) \\ R_2 &= 360 \text{ lb}\end{aligned}$$

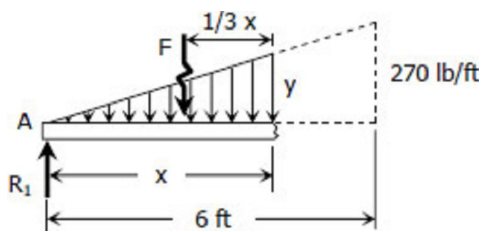

Segment AB:

$$\begin{aligned}\frac{y}{x} &= \frac{270}{6} \\ y &= 45x\end{aligned}$$

$$F = \frac{1}{2}xy = \frac{1}{2}x(45x)$$

$$F = 22.5x^2$$

$$\begin{aligned}V_{AB} &= R_1 - F \\ V_{AB} &= 450 - 22.5x^2 \text{ lb}\end{aligned}$$

$$\begin{aligned}M_{AB} &= R_1x - F\left(\frac{1}{3}x\right) \\ M_{AB} &= 450x - 22.5x^2\left(\frac{1}{3}x\right) \\ M_{AB} &= 450x - 7.5x^3 \text{ lb} \cdot \text{ft}\end{aligned}$$

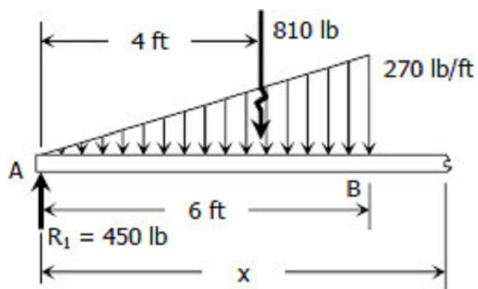

Segment BC:

$$\begin{aligned}V_{BC} &= 450 - 810 \\ V_{BC} &= -360 \text{ lb}\end{aligned}$$

$$\begin{aligned}M_{BC} &= 450x - 810(x - 4) \\ M_{BC} &= 450x - 810x + 3240 \\ M_{BC} &= 3240 - 360x \text{ lb} \cdot \text{ft}\end{aligned}$$

To draw the Shear Diagram:

- $V_{AB} = 450 - 22.5x^2$ is a second degree curve; at $x = 0$, $V_{AB} = 450$ lb; at $x = 6$ ft, $V_{AB} = -360$ lb.
- At $x = a$, $V_{AB} = 0$,

$$450 - 22.5x^2 = 0$$

$$22.5x^2 = 450$$

$$x^2 = 20$$

$$x = \sqrt{20}$$

To check, use the squared property of parabola.

$$a^2/450 = 62/(450 + 360)$$

$$a^2 = 20$$

$$a = \sqrt{20}$$

- $V_{BC} = -360$ lb is constant.

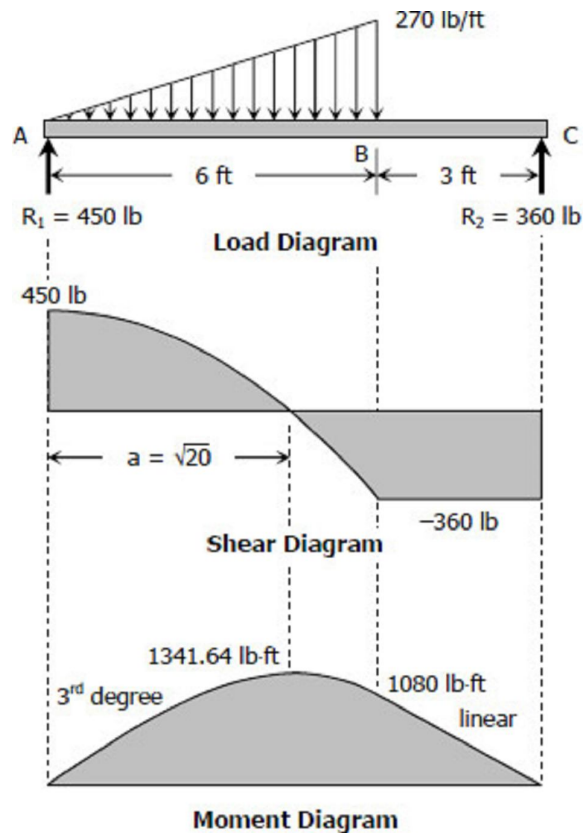

To draw the Moment Diagram:

- $M_{AB} = 450x - 7.5x^3$ for segment AB is third degree curve; at $x = 0$, $M_{AB} = 0$; at $x = \sqrt{20}$, $M_{AB} = 1341.64$ lb-ft; at $x = 6$ ft, $M_{AB} = 1080$ lb-ft.
- $M_{BC} = 3240 - 360x$ for segment BC is linear; at $x = 6$ ft, $M_{BC} = 1080$ lb-ft; at $x = 9$ ft, $M_{BC} = 0$.

Solution to Problem 420 | Shear and Moment Diagrams

A total distributed load of 30 kips supported by a uniformly distributed reaction as shown in [Fig. P-420](#). See the [instruction](#).

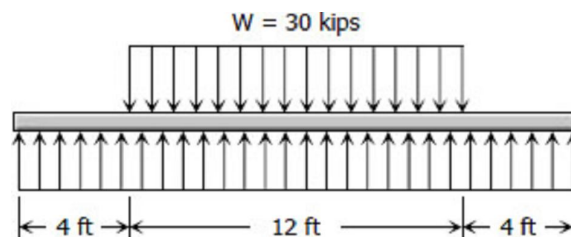
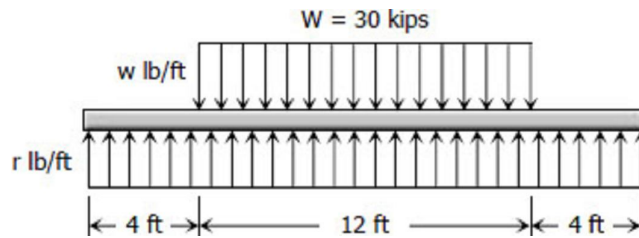

Figure P-420

Solution 420



$$w = 30(1000)/12$$

$$w = 2500 \text{ lb/ft}$$

$$\Sigma F_V = 0$$

$$R = W$$

$$20r = 30(1000)$$

$$r = 1500 \text{ lb/ft}$$

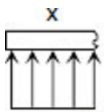

$$r = 1500 \text{ lb/ft}$$

First segment (from 0 to 4 ft from left):

$$V_1 = 1500x$$

$$M_1 = 1500x(x/2)$$

$$M_1 = 750x^2$$

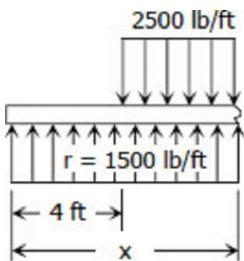

Second segment (from 4 ft to mid-span):

$$V_2 = 1500x - 2500(x-4)$$

$$V_2 = 10000 - 1000x$$

$$M_2 = 1500x(x/2) - 2500(x-4)(x-4)/2$$

$$M_2 = 750x^2 - 1250(x-4)^2$$

To draw the Shear Diagram:

1. For the first segment, $V_1 = 1500x$ is linear; at $x = 0$, $V_1 = 0$; at $x = 4$ ft, $V_1 = 6000$ lb.
2. For the second segment, $V_2 = 10000 - 1000x$ is also linear; at $x = 4$ ft, $V_2 = 6000$

lb; at mid-span, $x = 10$ ft, $V_1 = 0$.

- For the next half of the beam, the shear diagram can be accomplished by the concept of symmetry.

To draw the Moment Diagram:

- For the first segment, $M_1 = 750x^2$ is a second degree curve, an open upward parabola; at $x = 0$, $M_1 = 0$; at $x = 4$ ft, $M_1 = 12000$ lb-ft.
- For the second segment, $M_2 = 750x^2 - 1250(x - 4)^2$ is a second degree curve, an downward parabola; at $x = 4$ ft, $M_2 = 12000$ lb-ft; at mid-span, $x = 10$ ft, $M_2 = 30000$ lb-ft.

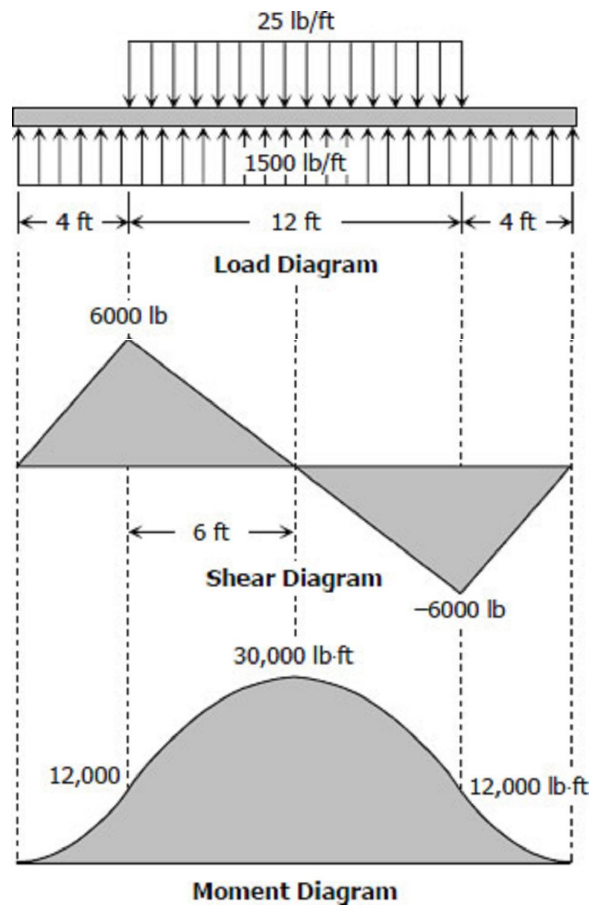

- The next half of the diagram, from $x = 10$ ft to $x = 20$ ft, can be drawn by using the concept of symmetry.

Solution to Problem 421 | Shear and Moment Equations

Write the shear and moment equations as functions of the angle θ for the built-in arch shown in [Fig. P-421](#).

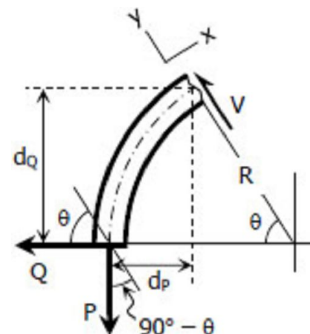
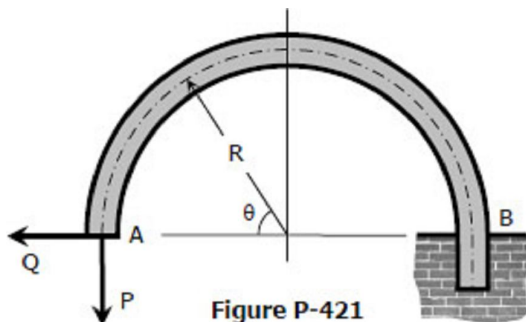

Solution 421

For θ that is less than 90°

Components of Q and P :

$$Q_x = Q \sin \theta$$

$$Q_y = Q \cos \theta$$

$$P_x = P \sin(90^\circ - \theta)$$

$$P_x = P (\sin 90^\circ \cos \theta - \cos 90^\circ \sin \theta)$$

$$P_x = P \cos \theta$$

$$P_y = P \cos(90^\circ - \theta)$$

$$P_y = P (\cos 90^\circ \cos \theta + \sin 90^\circ \sin \theta)$$

$$P_y = P \sin \theta$$

Shear:

$$V = \Sigma F_y$$

$$V = Q_y - P_y$$

$$V = Q \cos \theta - P \sin \theta \text{ answer}$$

Moment arms:

$$d_Q = R \sin \theta$$

$$d_P = R - R \cos \theta$$

$$d_P = R (1 - \cos \theta)$$

Moment:

$$M = \Sigma M_{\text{counterclockwise}} - \Sigma M_{\text{clockwise}}$$

$$M = Q(d_Q) - P(d_P)$$

$$M = QR \sin \theta - PR(1 - \cos \theta) \text{ answer}$$

For θ that is greater than 90°

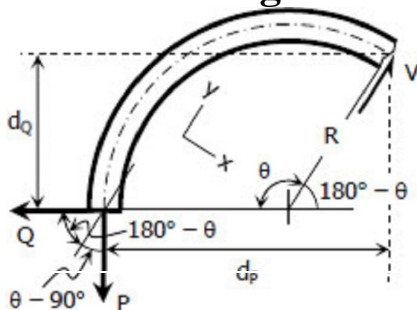

Components of Q and P:

$$Q_x = Q \sin(180^\circ - \theta)$$

$$Q_x = Q (\sin 180^\circ \cos \theta - \cos 180^\circ \sin \theta)$$

$$Q_x = Q \cos \theta$$

$$Q_y = Q \cos(180^\circ - \theta)$$

$$Q_y = Q(\cos 180^\circ \cos \theta + \sin 180^\circ \sin \theta)$$

$$Q_y = -Q \sin \theta$$

$$P_x = P \sin(\theta - 90^\circ)$$

$$P_x = P(\sin \theta \cos 90^\circ - \cos \theta \sin 90^\circ)$$

$$P_x = -P \cos \theta$$

$$P_y = P \cos(\theta - 90^\circ)$$

$$P_y = P(\cos \theta \cos 90^\circ + \sin \theta \sin 90^\circ)$$

$$P_y = P \sin \theta$$

Shear:

$$V = \Sigma F_y$$

$$V = -Q_y - P_y$$

$$V = -(-Q \sin \theta) - P \sin \theta$$

$$V = Q \sin \theta - P \sin \theta \text{ answer}$$

Moment arms:

$$d_Q = R \sin(180^\circ - \theta)$$

$$d_Q = R(\sin 180^\circ \cos \theta - \cos 180^\circ \sin \theta)$$

$$d_Q = R \sin \theta$$

$$d_P = R + R \cos(180^\circ - \theta)$$

$$d_P = R + R(\cos 180^\circ \cos \theta + \sin 180^\circ \sin \theta)$$

$$d_P = R - R \cos \theta$$

$$d_P = R(1 - \cos \theta)$$

Moment:

$$M = \Sigma M_{\text{counterclockwise}} - \Sigma M_{\text{clockwise}}$$

$$M = Q(d_Q) - P(d_P)$$

$$M = QR \sin \theta - PR(1 - \cos \theta) \text{ answer}$$

Solution to Problem 422 | Shear and Moment Equations

Write the shear and moment equations for the semicircular arch as shown in [Fig. P-422](#) if (a) the load P is vertical as shown, and (b) the load is applied horizontally to the left at the top of the arch.

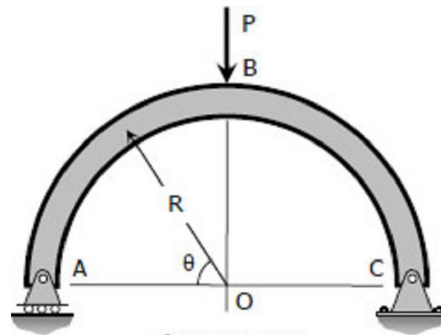
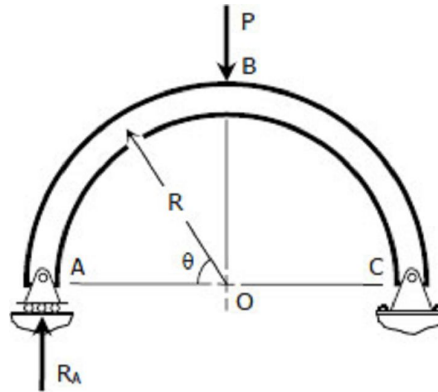

Figure P-422

Solution 422

$$\begin{aligned} \sum M_C &= 0 \\ 2R(R_A) &= RP \\ R_A &= \frac{1}{2}P \end{aligned}$$



For θ that is less than 90°

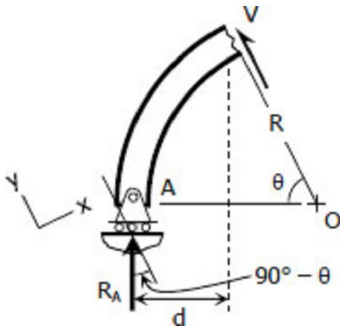

Shear:

$$\begin{aligned} V_{AB} &= R_A \cos(90^\circ - \theta) \\ V_{AB} &= \frac{1}{2}P (\cos 90^\circ \cos \theta + \sin 90^\circ \sin \theta) \\ V_{AB} &= \frac{1}{2}P \sin \theta \text{ answer} \end{aligned}$$

Moment arm:

$$\begin{aligned} d &= R - R \cos \theta \\ d &= R(1 - \cos \theta) \end{aligned}$$

Moment:

$$M_{AB} = R_A(d)$$

$$M_{AB} = \frac{1}{2}PR(1 - \cos \theta) \text{ answer}$$

For θ that is greater than 90°

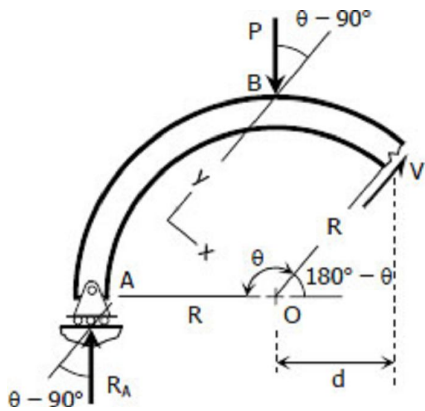

Components of P and R_A :

$$P_x = P \sin(\theta - 90^\circ)$$

$$P_x = P(\sin \theta \cos 90^\circ - \cos \theta \sin 90^\circ)$$

$$P_x = -P \cos \theta$$

$$P_y = P \cos(\theta - 90^\circ)$$

$$P_y = P(\cos \theta \cos 90^\circ + \sin \theta \sin 90^\circ)$$

$$P_y = P \sin \theta$$

$$R_{Ax} = R_A \sin(\theta - 90^\circ)$$

$$R_{Ax} = \frac{1}{2}P(\sin \theta \cos 90^\circ - \cos \theta \sin 90^\circ)$$

$$R_{Ax} = -\frac{1}{2}P \cos \theta$$

$$R_{Ay} = R_A \cos(\theta - 90^\circ)$$

$$R_{Ay} = \frac{1}{2}P(\cos \theta \cos 90^\circ + \sin \theta \sin 90^\circ)$$

$$R_{Ay} = \frac{1}{2}P \sin \theta$$

Shear:

$$V_{BC} = \sum F_y$$

$$V_{BC} = R_{Ay} - P_y$$

$$V_{BC} = \frac{1}{2}P \sin \theta - P \sin \theta$$

$$V_{BC} = -\frac{1}{2}P \sin \theta \text{ answer}$$

Moment arm:

$$d = R \cos(180^\circ - \theta)$$

$$d = R(\cos 180^\circ \cos \theta + \sin 180^\circ \sin \theta)$$

$$d = -R \cos \theta$$

Moment:

$$M_{BC} = \sum M_{counterclockwise} - \sum M_{clockwise}$$

$$M_{BC} = R_A(R + d) - Pd$$

$$M_{BC} = \frac{1}{2}P(R - R \cos \theta) - P(-R \cos \theta)$$

$$M_{BC} = \frac{1}{2}PR - \frac{1}{2}PR \cos \theta + PR \cos \theta$$

$$M_{BC} = \frac{1}{2}PR + \frac{1}{2}PR \cos \theta$$

$$M_{BC} = \frac{1}{2}PR(1 + \cos \theta) \text{ answer}$$

Relationship Between Load, Shear, and Moment

The vertical shear at C in the figure shown in [previous section](#) (Shear and Moment Diagram) is taken as

$$V_C = (\sum F_v)_L = R_1 - wx$$

where $R_1 = R_2 = wL/2$

$$V_c = \frac{wL}{2} - wx$$

The moment at C is

$$M_C = (\sum M_C) = \frac{wL}{2}x - wx \left(\frac{x}{2} \right)$$

$$M_C = \frac{wLx}{2} - \frac{wx^2}{2}$$

If we differentiate M with respect to x:

$$\frac{dM}{dx} = \frac{wL}{2} \cdot \frac{dx}{dx} - \frac{w}{2} \left(2x \cdot \frac{dx}{dx} \right)$$

$$\frac{dM}{dx} = \frac{wL}{2} - wx = \text{shear}$$

thus,

$$\frac{dM}{dx} = V$$

Thus, the rate of change of the bending moment with respect to x is equal to the shearing force, or **the slope of the moment diagram at the given point is the shear at that point.**

Differentiate V with respect to x gives

$$\frac{dV}{dx} = 0 - w$$

thus,

$$\frac{dV}{dx} = \text{Load}$$

Thus, the rate of change of the shearing force with respect to x is equal to the load or **the slope of the shear diagram at a given point equals the load at that point.**

Properties of Shear and Moment Diagrams

The following are some important properties of shear and moment diagrams:

1. The area of the shear diagram to the left or to the right of the section is equal to the moment at that section.
2. The slope of the moment diagram at a given point is the shear at that point.
3. The slope of the shear diagram at a given point equals the load at that point.
4. The maximum moment occurs at the point of zero shears. This is in reference to property number 2, that when the shear (also the slope of the moment diagram) is zero, the tangent drawn to the moment diagram is horizontal.
5. When the shear diagram is increasing, the moment diagram is concave upward.
6. When the shear diagram is decreasing, the moment diagram is concave downward.

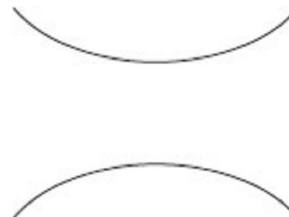

Sign Convention

The customary sign conventions for shearing force and bending moment are represented by the figures below. A force that tends to bend the beam downward is said to produce a positive bending moment. A force that tends to shear the left portion of the beam upward with respect to the right portion is said to

produce a positive shearing force.

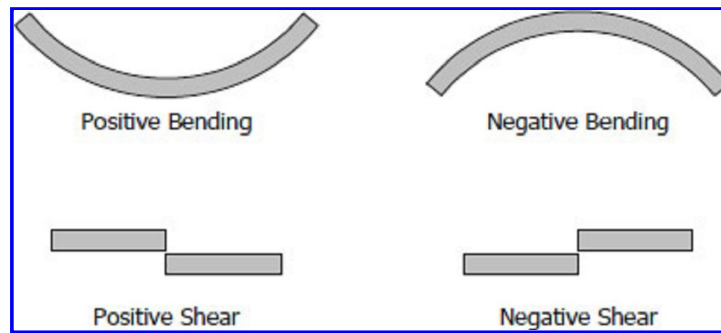

An easier way of determining the sign of the bending moment at any section is that upward forces always cause positive bending moments regardless of whether they act to the left or to the right of the exploratory section.

INSTRUCTION:

Without writing shear and moment equations, draw the shear and moment diagrams for the beams specified in the following problems. Give numerical values at all change of loading positions and at all points of zero shear. (Note to instructor: Problems 403 to 420 may also be assigned for solution by semi-graphical method describes in this article.)

Solution to Problem 425 | Relationship Between Load, Shear, and Moment

Beam loaded as shown in [Fig. P-425](#). See the [instruction](#).

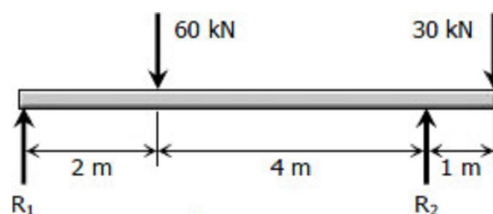

Figure P-425

Solution 425

$$\Sigma M_A = 0$$

$$6R_2 = 2(60) + 7(30)$$

$$R_2 = 55 \text{ kN}$$

$$\Sigma M_C = 0$$

$$6R_1 + 1(30) = 4(60)$$

$$R_1 = 35 \text{ kN}$$

To draw the Shear Diagram:

1. $V_A = R_1 = 35 \text{ kN}$
2. $V_B = V_A + \text{Area in load diagram} - 60 \text{ kN}$
 $V_B = 35 + 0 - 60 = -25 \text{ kN}$
3. $V_C = V_B + \text{area in load diagram} + R_2$
 $V_C = -25 + 0 + 55 = 30 \text{ kN}$
4. $V_D = V_C + \text{Area in load diagram} - 30 \text{ kN}$
 $V_D = 30 + 0 - 30 = 0$

To draw the Moment Diagram:

1. $M_A = 0$
2. $M_B = M_A + \text{Area in shear diagram}$
 $M_B = 0 + 35(2) = 70 \text{ kN}\cdot\text{m}$
3. $M_C = M_B + \text{Area in shear diagram}$
 $M_C = 70 - 25(4) = -30 \text{ kN}\cdot\text{m}$
4. $M_D = M_C + \text{Area in shear diagram}$
 $M_D = -30 + 30(1) = 0$

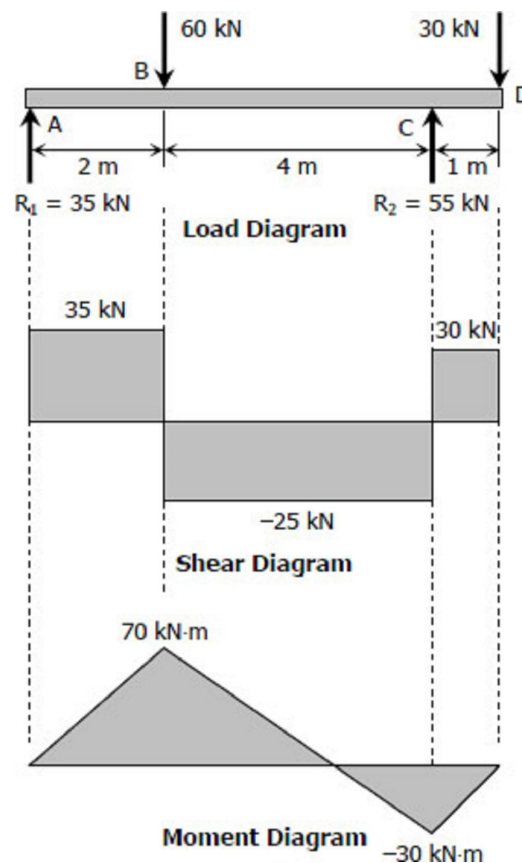

Solution to Problem 426 | Relationship Between Load, Shear, and Moment

Cantilever beam acted upon by a uniformly distributed load and a couple as shown in [Fig. P-426](#). See the [instruction](#).

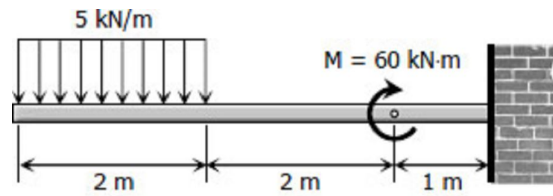

Figure P-426

Solution 426

To draw the Shear Diagram

1. $V_A = 0$
2. $V_B = V_A + \text{Area in load diagram}$
 $V_B = 0 - 5(2)$
 $V_B = -10 \text{ kN}$
3. $V_C = V_B + \text{Area in load diagram}$
 $V_C = -10 + 0$
 $V_C = -10 \text{ kN}$
4. $V_D = V_C + \text{Area in load diagram}$
 $V_D = -10 + 0$
 $V_D = -10 \text{ kN}$

To draw the Moment Diagram

1. $M_A = 0$
2. $M_B = M_A + \text{Area in shear diagram}$
 $M_B = 0 - \frac{1}{2}(2)(10)$
 $M_B = -10 \text{ kN}\cdot\text{m}$
3. $M_C = M_B + \text{Area in shear diagram}$
 $M_C = -10 - 10(2)$
 $M_C = -30 \text{ kN}\cdot\text{m}$
 $M_{C2} = -30 + M = -30 + 60 = 30 \text{ kN}\cdot\text{m}$
4. $M_D = M_{C2} + \text{Area in shear diagram}$
 $M_D = 30 - 10(1)$
 $M_D = 20 \text{ kN}\cdot\text{m}$

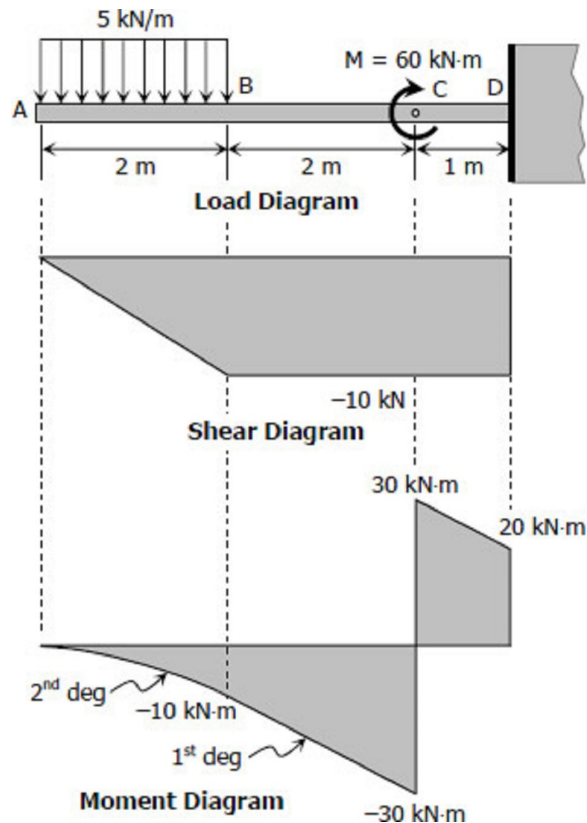

Solution to Problem 427 | Relationship Between Load, Shear, and Moment

Beam loaded as shown in [Fig. P-427](#). See the [instruction](#).

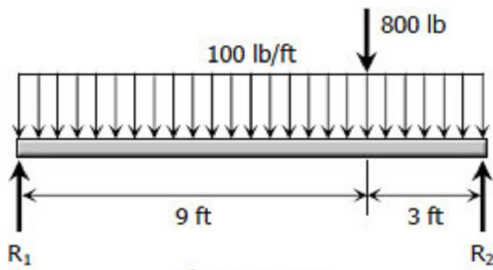

Figure P-427

Solution 427

$$\sum M_C = 0$$

$$12R_1 = 100(12)(6) + 800(3)$$

$$R_1 = 800 \text{ lb}$$

$$\sum M_A = 0$$

$$12R_2 = 100(12)(6) + 800(9)$$

$$R_2 = 1200 \text{ lb}$$

To draw the Shear Diagram

1. $V_A = R_1 = 800 \text{ lb}$
2. $V_B = V_A + \text{Area in load diagram}$
 $V_B = 800 - 100(9)$
 $V_B = -100 \text{ lb}$
 $V_{B2} = -100 - 800 = -900 \text{ lb}$
3. $V_C = V_{B2} + \text{Area in load diagram}$
 $V_C = -900 - 100(3)$
 $V_C = -1200 \text{ lb}$
4. Solving for x :
 $x / 800 = (9 - x) / 100$
 $100x = 7200 - 800x$
 $x = 8 \text{ ft}$

To draw the Moment Diagram

1. $M_A = 0$
2. $M_x = M_A + \text{Area in shear diagram}$
 $M_x = 0 + \frac{1}{2}(8)(800) = 3200 \text{ lb}\cdot\text{ft}$;
3. $M_B = M_x + \text{Area in shear diagram}$

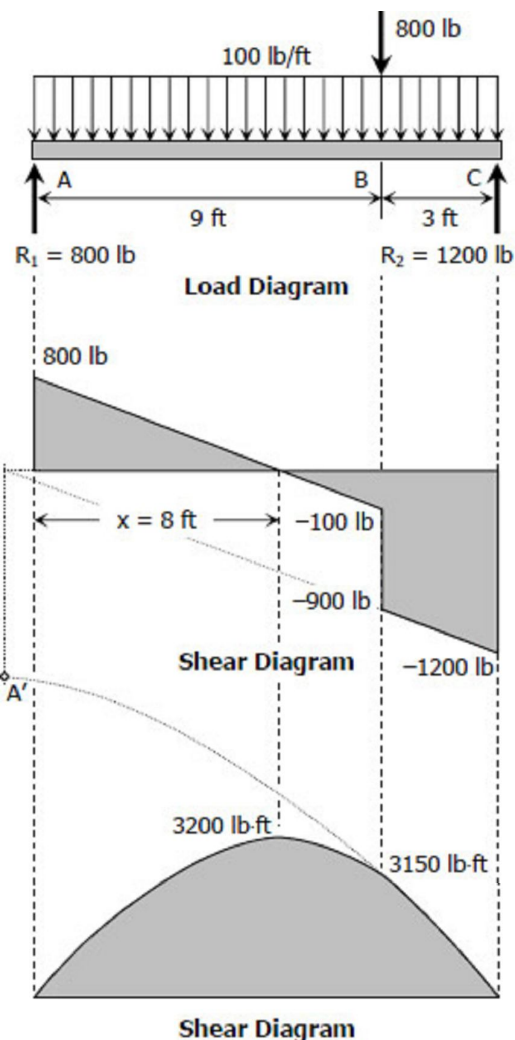

$$M_B = 3200 - \frac{1}{2}(1)(100) = 3150 \text{ lb}\cdot\text{ft}$$

4. $M_C = M_B + \text{Area in shear diagram}$

$$M_C = 3150 - \frac{1}{2}(900 + 1200)(3) = 0$$

5. The moment curve BC is downward parabola with vertex at A'. A' is the location of zero shear for segment BC.

Solution to Problem 428 | Relationship Between Load, Shear, and Moment

Beam loaded as shown in [Fig. P-428](#). See the [instruction](#).

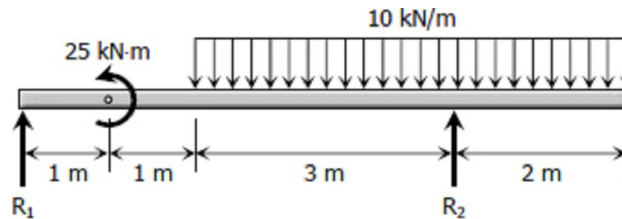

Figure P-428

Solution 428

$$\sum M_D = 0$$

$$5R_1 = 50(0.5) + 25$$

$$R_1 = 10 \text{ kN}$$

$$\sum M_A = 0$$

$$5R_2 + 25 = 50(4.5)$$

$$R_2 = 40 \text{ kN}$$

To draw the Shear Diagram

1. $V_A = R_1 = 10 \text{ kN}$
2. $V_B = V_A + \text{Area in load diagram}$

- $V_B = 10 + 0 = 10 \text{ kN}$
 3. $V_C = V_B + \text{Area in load diagram}$
 $V_C = 10 + 0 = 10 \text{ kN}$
 4. $V_D = V_C + \text{Area in load diagram}$
 $V_D = 10 - 10(3) = -20 \text{ kN}$
 $V_{D2} = -20 + R_2 = 20 \text{ kN}$
 5. $V_E = V_{D2} + \text{Area in load diagram}$
 $V_E = 20 - 10(2) = 0$
 6. **Solving for x:**
 $x / 10 = (3 - x) / 20$
 $20x = 30 - 10x$
 $x = 1 \text{ m}$

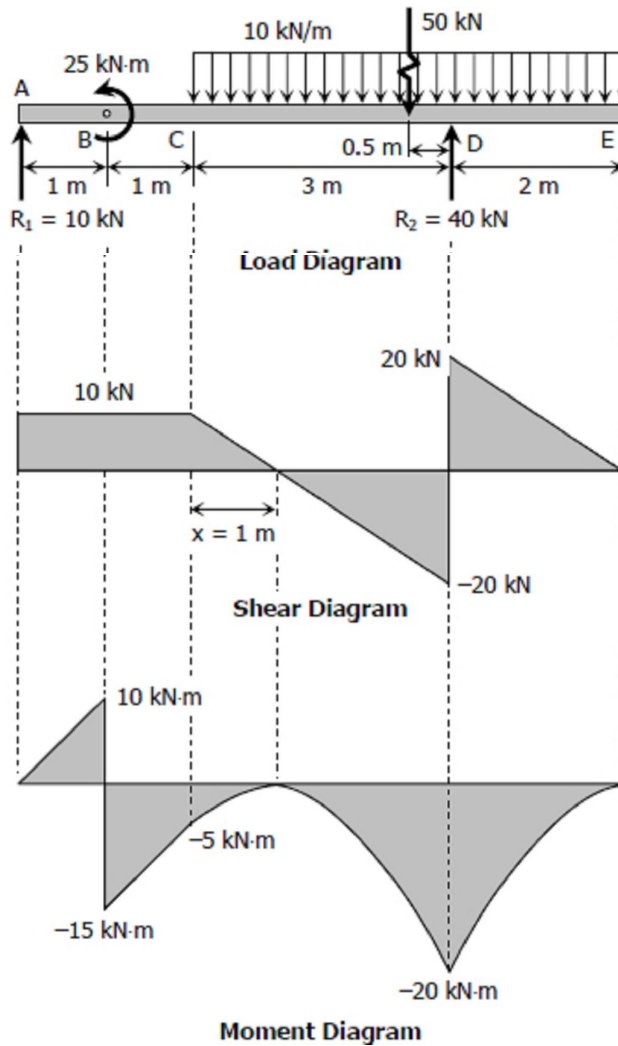

To draw the Moment Diagram

- $M_A = 0$
- $M_B = M_A + \text{Area in shear diagram}$
 $M_B = 0 + 1(10) = 10 \text{ kN}\cdot\text{m}$
 $M_{B2} = 10 - 25 = -15 \text{ kN}\cdot\text{m}$
- $M_C = M_{B2} + \text{Area in shear diagram}$
 $M_C = -15 + 1(10) = -5 \text{ kN}\cdot\text{m}$
- $M_x = M_C + \text{Area in shear diagram}$
 $M_x = -5 + \frac{1}{2}(1)(10) = 0$
- $M_D = M_x + \text{Area in shear diagram}$
 $M_D = 0 - \frac{1}{2}(2)(20) = -20 \text{ kN}\cdot\text{m}$
- $M_E = M_D + \text{Area in shear diagram}$
 $M_E = -20 + \frac{1}{2}(2)(20) = 0$

Solution to Problem 429 | Relationship Between Load, Shear, and Moment

Beam loaded as shown in [Fig. P-429](#). See the [instruction](#).

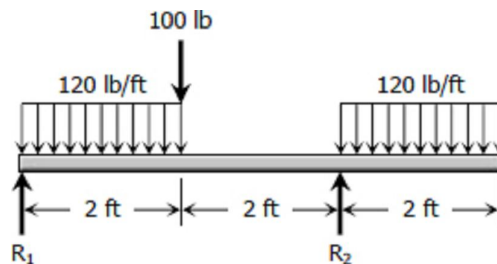

Figure P-429

Solution 429

$$\Sigma M_C = 0$$

$$4R_1 + 120(2)(1) = 100(2) + 120(2)(3)$$

$$R_1 = 170 \text{ lb}$$

$$\Sigma M_A = 0$$

$$4R_2 = 120(2)(1) + 100(2) + 120(2)(5)$$

$$R_2 = 410 \text{ lb}$$

To draw the Shear Diagram

- $V_A = R_1 = 170 \text{ lb}$
- $V_B = V_A + \text{Area in load diagram}$
 $V_B = 170 - 120(2) = -70 \text{ lb}$
 $V_{B2} = -70 - 100 = -170 \text{ lb}$
- $V_C = V_{B2} + \text{Area in load diagram}$
 $V_C = -170 + 0 = -170 \text{ lb}$
 $V_{C2} = -170 + R_2$
 $V_{C2} = -170 + 410 = 240 \text{ lb}$
- $V_D = V_{C2} + \text{Area in load diagram}$
 $V_D = 240 - 120(2) = 0$
- Solving for x:**
 $x / 170 = (2 - x) / 70$
 $70x = 340 - 170x$
 $x = 17 / 12 \text{ ft} = 1.42 \text{ ft}$

To draw the Moment Diagram

- $M_A = 0$
- $M_x = M_A + \text{Area in shear diagram}$
 $M_x = 0 + (17/12)(170)$
 $M_x = 1445/12 = 120.42 \text{ lb}\cdot\text{ft}$
- $M_B = M_x + \text{Area in shear diagram}$
 $M_B = 1445/12 - \frac{1}{2}(2 - 17/12)(70)$
 $M_B = 100 \text{ lb}\cdot\text{ft}$
- $M_C = M_B + \text{Area in shear diagram}$
 $M_C = 100 - 170(2) = -240 \text{ lb}\cdot\text{ft}$
- $M_D = M_C + \text{Area in shear diagram}$
 $M_D = -240 + \frac{1}{2}(2)(240) = 0$

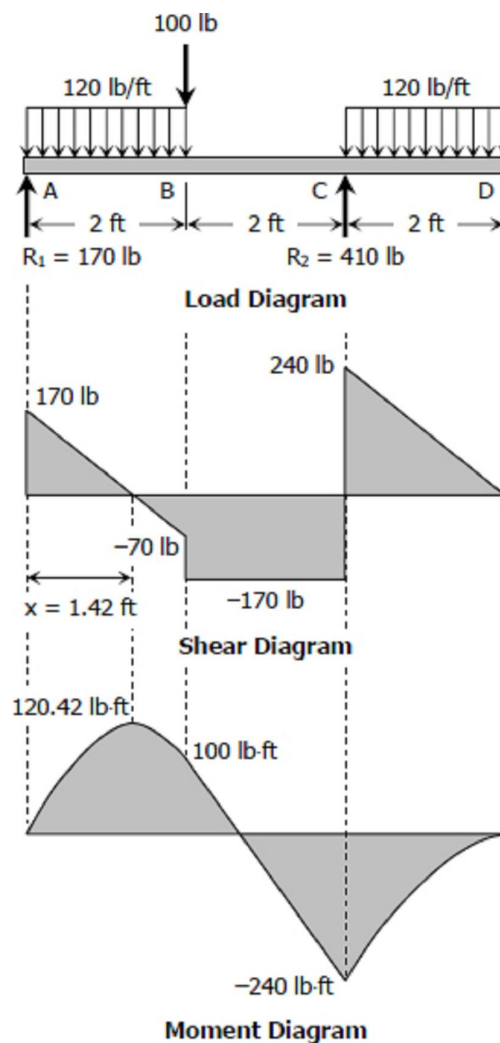

Solution to Problem 430 | Relationship Between Load, Shear, and Moment

Beam loaded as shown in [Fig. P-430](#). See the [instruction](#).

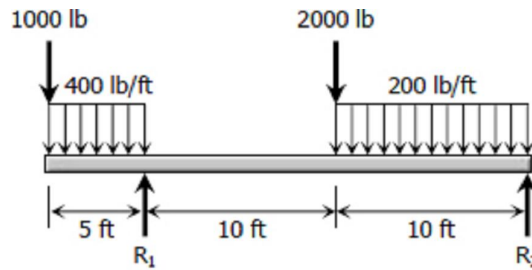

Figure P-430

Solution 430

$$\sum M_D = 0$$

$$20R_1 = 1000(25) + 400(5)(22.5) + 2000(10) + 200(10)(5)$$

$$R_1 = 5000 \text{ lb}$$

$$\sum M_B = 0$$

$$20R_2 + 1000(5) + 400(5)(2.5) = 2000(10) + 200(10)(15)$$

$$R_2 = 2000 \text{ lb}$$

To draw the Shear Diagram

1. $V_A = -1000 \text{ lb}$
2. $V_B = V_A + \text{Area in load diagram}; V_B = -1000 - 400(5) = -3000 \text{ lb}; V_{B2} = -3000 + R_1 = 2000 \text{ lb}$
3. $V_C = V_{B2} + \text{Area in load diagram}; V_C = 2000 + 0 = 2000 \text{ lb}; V_{C2} = 2000 - 2000 = 0$
4. $V_D = V_{C2} + \text{Area in load diagram}; V_D = 0 + 200(10) = 2000 \text{ lb}$

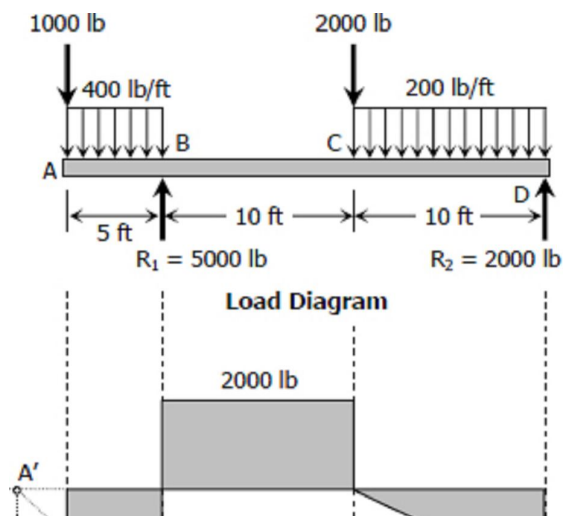

To draw the Moment Diagram

1. $M_A = 0$
2. $M_B = M_A + \text{Area in shear diagram}$
 $M_B = 0 - \frac{1}{2} (1000 + 3000)(5)$
 $M_B = -10000 \text{ lb}\cdot\text{ft}$
3. $M_C = M_B + \text{Area in shear diagram}$
 $M_C = -10000 + 2000(10) = 10000 \text{ lb}\cdot\text{ft}$
4. $M_D = M_C + \text{Area in shear diagram}$
 $M_D = 10000 - \frac{1}{2} (10)(2000) = 0$
5. For segment BC, the location of zero moment can be accomplished by symmetry and that is 5 ft from B.
6. The moment curve AB is a downward parabola with vertex at A'. A' is the location of zero shear for segment AB at point outside the beam.

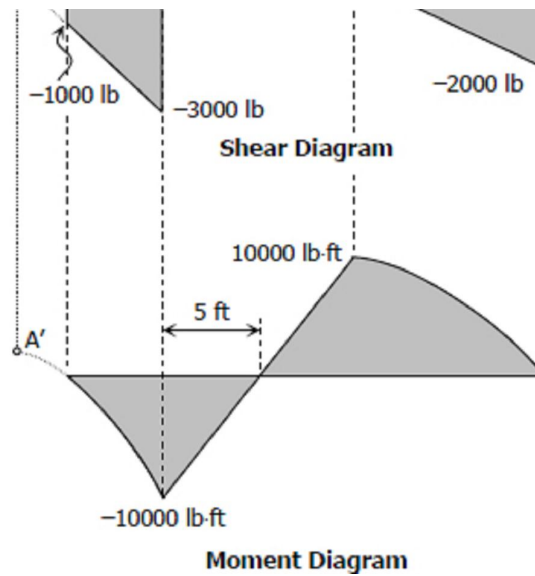

Solution to Problem 431 | Relationship Between Load, Shear, and Moment

Beam loaded as shown in [Fig. P-431](#). See the [instruction](#).

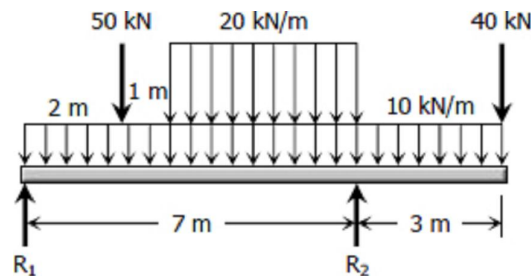

Figure P-431

$$\begin{aligned} \sum M_D &= 0 \\ 7R_1 + 40(3) &= 5(50) + 10(10)(2) + 20(4)(2) \\ R_1 &= 70 \text{ kN} \end{aligned}$$

$$\begin{aligned} \sum M_A &= 0 \\ 7R_2 &= 50(2) + 10(10)(5) + 20(4)(5) + 40(10) \end{aligned}$$

$$R_2 = 200 \text{ lb}$$

To draw the Shear Diagram

- $V_A = R_1 = 70 \text{ kN}$
- $V_B = V_A + \text{Area in load diagram}$
 $V_B = 70 - 10(2) = 50 \text{ kN}$
 $V_{B2} = 50 - 50 = 0$
- $V_C = V_{B2} + \text{Area in load diagram}$
 $V_C = 0 - 10(1) = -10 \text{ kN}$
- $V_D = V_C + \text{Area in load diagram}$
 $V_D = -10 - 30(4) = -130 \text{ kN}$
 $V_{D2} = -130 + R_2$
 $V_{D2} = -130 + 200 = 70 \text{ kN}$
- $V_E = V_{D2} + \text{Area in load diagram}; V_E = 70 - 10(3) = 40 \text{ kN}$
 $V_{E2} = 40 - 40 = 0$

To draw the Moment Diagram

- $M_A = 0$
- $M_B = M_A + \text{Area in shear diagram}$
 $M_B = 0 + \frac{1}{2} (70 + 50)(2) = 120 \text{ kN}\cdot\text{m}$
- $M_C = M_B + \text{Area in shear diagram}$
 $M_C = 120 - \frac{1}{2} (1)(10) = 115 \text{ kN}\cdot\text{m}$
- $M_D = M_C + \text{Area in shear diagram}$
 $M_D = 115 - \frac{1}{2} (10 + 130)(4) = -165 \text{ kN}\cdot\text{m}$
- $M_E = M_D + \text{Area in shear diagram}$
 $M_E = -165 + \frac{1}{2} (70 + 40)(3) = 0$
- Moment curves AB, CD and DE are downward parabolas with vertices at A', B' and C', respectively. A', B' and C' are corresponding zero shear points of segments AB, CD and DE.

7. Solving for point of zero moment:

$$\begin{aligned} a / 10 &= (a + 4) / 130 \\ 130a &= 10a + 40 \\ a &= 1/3 \text{ m} \end{aligned}$$

$$\begin{aligned} y / (x + a) &= 130 / (4 + a) \\ y &= 130(x + 1/3) / (4 + 1/3) \\ y &= 30x + 10 \end{aligned}$$

$$M_C = 115 \text{ kN}\cdot\text{m}$$

$$M_{\text{zero}} = M_C + \text{Area in shear}$$

$$0 = 115 - \frac{1}{2} (10 + y)x$$

$$(10 + y)x = 230$$

$$(10 + 30x + 10)x = 230$$

$$30x^2 + 20x - 230 = 0$$

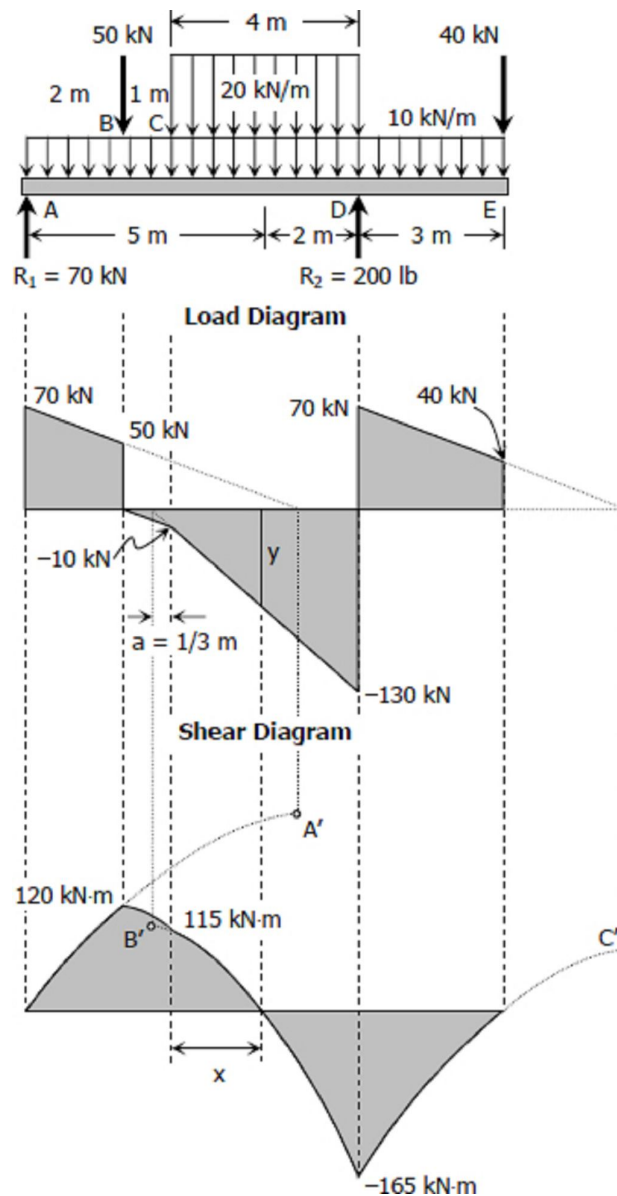

$$3x^2 + 2x - 23 = 0$$
$$x = 2.46 \text{ m}$$

Zero moment is at 2.46 m from C

Another way to solve the location of zero moment is by the squared property of parabola (see [Problem 434](#)). This point is the appropriate location for construction joint of concrete structures.

Solution to Problem 432 | Relationship Between Load, Shear, and Moment

Problem 432

Beam loaded as shown in [Fig. P-432](#). See the [instruction](#).

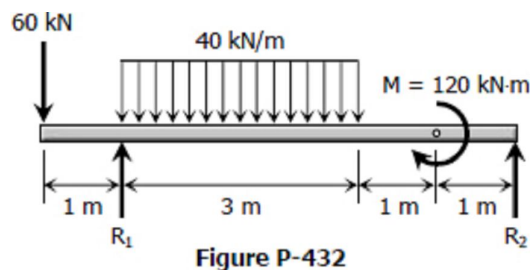

Solution 432

$$\sum M_E = 0$$
$$5R_1 + 120 = 6(60) + 40(3)(3.5)$$
$$R_1 = 132 \text{ kN}$$

$$\sum M_B = 0$$
$$5R_2 + 60(1) = 40(3)(1.5) + 120$$
$$R_2 = 48 \text{ kN}$$

To draw the Shear Diagram

- $V_A = -60 \text{ kN}$
- $V_B = V_A + \text{Area in load diagram}$
 $V_B = -60 + 0 = -60 \text{ kN}$
 $V_{B2} = V_B + R_1 = -60 + 132 = 72 \text{ kN}$
- $V_C = V_{B2} + \text{Area in load diagram}$
 $V_C = 72 - 3(40) = -48 \text{ kN}$
- $V_D = V_C + \text{Area in load diagram}$
 $V_D = -48 + 0 = -48 \text{ kN}$
- $V_E = V_D + \text{Area in load diagram}$
 $V_E = -48 + 0 = -48 \text{ kN}$
 $V_{E2} = V_E + R_2 = -48 + 48 = 0$
- Solving for x:**
 $x / 72 = (3 - x) / 48$
 $48x = 216 - 72x$
 $x = 1.8 \text{ m}$

To draw the Moment Diagram

- $M_A = 0$
- $M_B = M_A + \text{Area in shear diagram}$
 $M_B = 0 - 60(1) = -60 \text{ kN}\cdot\text{m}$
- $M_x = M_B + \text{Area in shear diagram}$
 $M_x = -60 + \frac{1}{2}(1.8)(72) = 4.8 \text{ kN}\cdot\text{m}$
- $M_C = M_x + \text{Area in shear diagram}$
 $M_C = 4.8 - \frac{1}{2}(3 - 1.8)(48) = -24 \text{ kN}\cdot\text{m}$
- $M_D = M_C + \text{Area in shear diagram}$
 $M_D = -24 - \frac{1}{2}(24 + 72)(1) = -72 \text{ kN}\cdot\text{m}$
- $M_{D2} = -72 + 120 = 48 \text{ kN}\cdot\text{m}$
- $M_E = M_{D2} + \text{Area in shear diagram}$
 $M_E = 48 - 48(1) = 0$

The location of zero moment on segment BC can be determined using the squared property parabola. See the solution of [Problem 434](#)

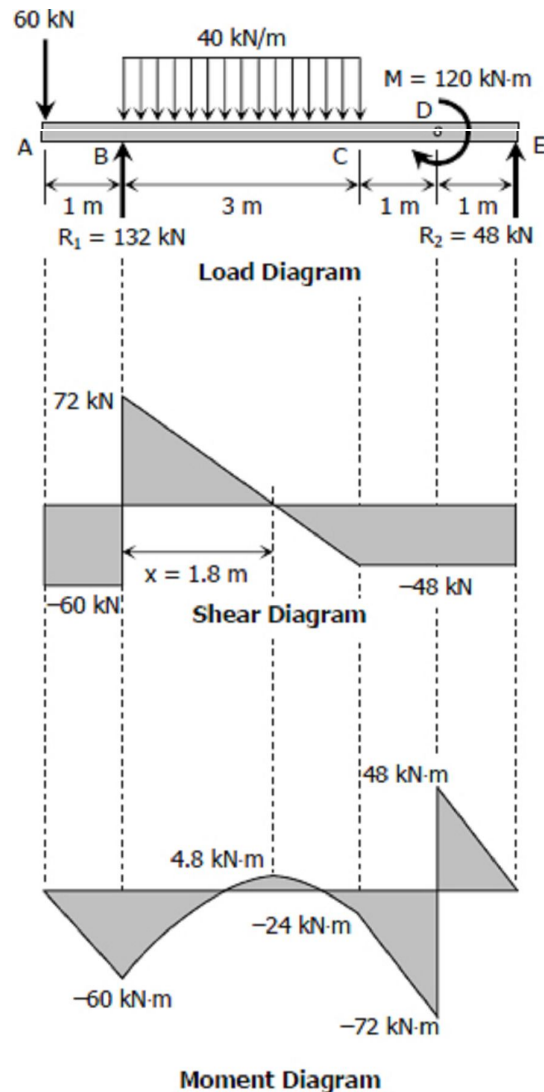

y of

Solution to Problem 433 | Relationship Between Load, Shear, and Moment

Overhang beam loaded by a force and a couple as shown in [Fig. P-433](#). See the [instruction](#).

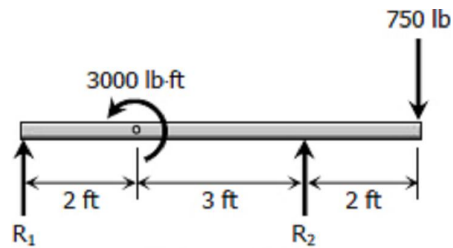

Figure P-433

Solution 433

$$\sum M_C = 0$$

$$5R_1 + 2(750) = 3000$$

$$R_1 = 300 \text{ lb}$$

$$\sum M_A = 0$$

$$5R_2 + 3000 = 7(750)$$

$$R_2 = 450 \text{ lb}$$

To draw the Shear Diagram

1. $V_A = R_1 = 300 \text{ lb}$
2. $V_B = V_A + \text{Area in load diagram}$
 $V_B = 300 + 0 = 300 \text{ lb}$
3. $V_C = V_B + \text{Area in load diagram}$
 $V_C = 300 + 0 = 300 \text{ lb}$
 $V_{C2} = V_C + R_2 = 300 + 450 = 750 \text{ lb}$
4. $V_D = V_{C2} + \text{Area in load diagram}$
 $V_D = 750 + 0 = 750$
 $V_{D2} = V_D - 750 = 750 - 750 = 0$

To draw the Moment Diagram

1. $M_A = 0$
2. $M_B = V_A + \text{Area in shear diagram}$
 $M_B = 0 + 300(2) = 600 \text{ lb}\cdot\text{ft}$
 $M_{B2} = V_B - 3000$
 $M_{B2} = 600 - 3000 = -2400 \text{ lb}\cdot\text{ft}$
3. $M_C = M_{B2} + \text{Area in shear diagram}$
 $M_C = -2400 + 300(3) = -1500 \text{ lb}\cdot\text{ft}$
4. $M_D = M_C + \text{Area in shear diagram}$
 $M_D = -1500 + 750(2) = 0$

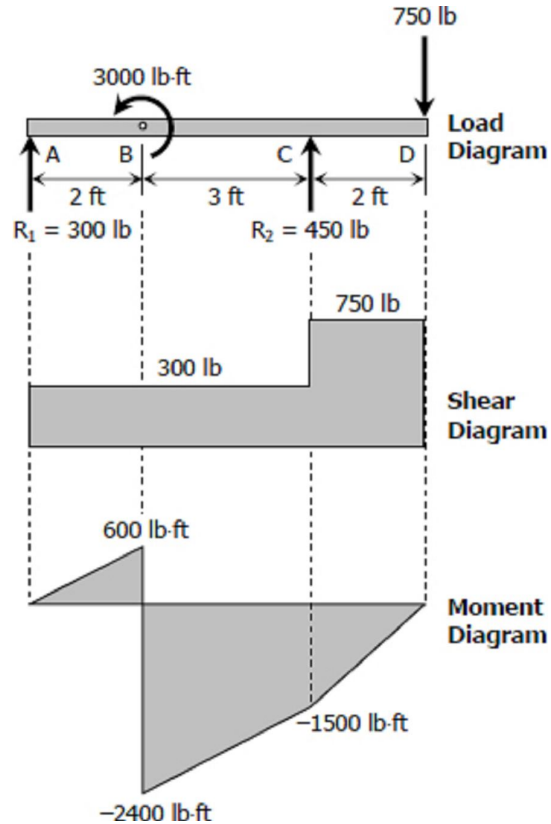

Solution to Problem 434 | Relationship Between Load, Shear, and Moment

Beam loaded as shown in [Fig. P-434](#). See the [instruction](#).

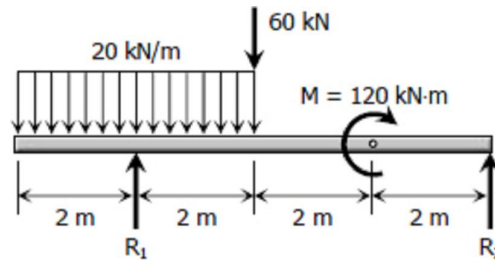

Figure P-434

Solution 434

$$\sum M_E = 0$$

$$6R_1 + 120 = 20(4)(6) + 60(4)$$

$$R_1 = 100 \text{ kN}$$

$$\sum M_B = 0$$

$$6R_2 = 20(4)(0) + 60(2) + 120$$

$$R_2 = 40 \text{ kN}$$

To draw the Shear Diagram

1. $V_A = 0$
2. $V_B = V_A + \text{Area in load diagram}$
 $V_B = 0 - 20(2) = -40 \text{ kN}$
 $V_{B2} = V_B + R_1 = -40 + 100 = 60 \text{ kN}$
3. $V_C = V_{B2} + \text{Area in load diagram}$
 $V_C = 60 - 20(2) = 20 \text{ kN}$
 $V_{C2} = V_C - 60 = 20 - 60 = -40 \text{ kN}$
4. $V_D = V_{C2} + \text{Area in load diagram}$

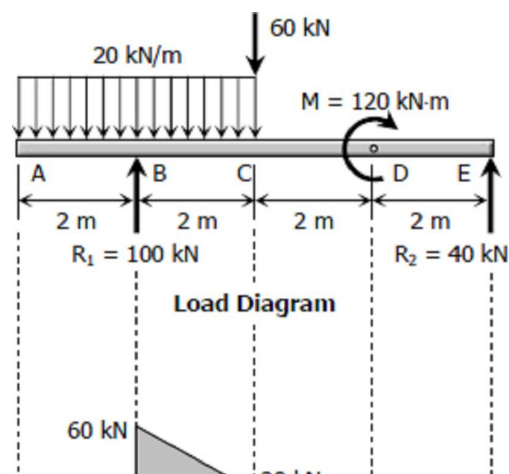

$$V_D = -40 + 0 = -40 \text{ kN}$$

$$5. V_E = V_D + \text{Area in load diagram}$$

$$V_E = -40 + 0 = -40 \text{ kN}$$

$$V_{E2} = V_E + R_2 = -40 + 40 = 0$$

To draw the Moment Diagram

$$1. M_A = 0$$

$$2. M_B = M_A + \text{Area in shear diagram}$$

$$M_B = 0 - \frac{1}{2}(40)(2) = -40 \text{ kN}\cdot\text{m}$$

$$3. M_C = M_B + \text{Area in shear diagram}$$

$$M_C = -40 + \frac{1}{2}(60 + 20)(2) = 40 \text{ kN}\cdot\text{m}$$

$$4. M_D = M_C + \text{Area in shear diagram}$$

$$M_D = 40 - 40(2) = -40 \text{ kN}\cdot\text{m}$$

$$M_{D2} = M_D + M = -40 + 120 = 80 \text{ kN}\cdot\text{m}$$

$$5. M_E = M_{D2} + \text{Area in shear diagram}$$

$$M_E = 80 - 40(2) = 0$$

6. Moment curve BC is a downward parabola with vertex at C'. C' is the location of zero shear for segment BC.

7. **Location of zero moment at segment BC:**

By squared property of parabola:

$$3 - x)^2 / 50 = 32 / (50 + 40)$$

$$3 - x = 2.236$$

$$x = 0.764 \text{ m from B}$$

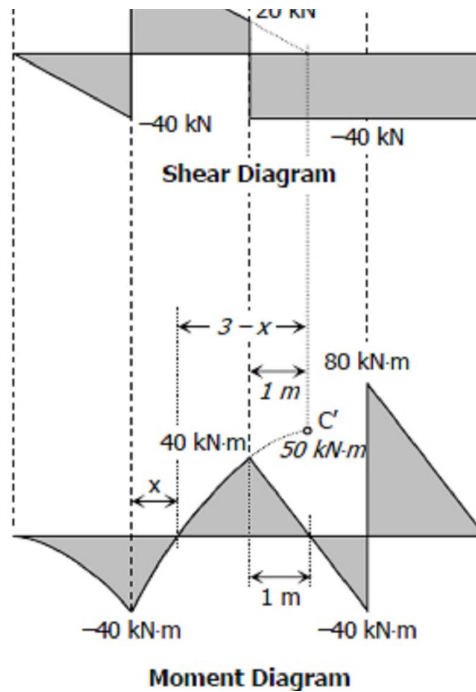

Solution to Problem 435 | Relationship Between Load, Shear, and Moment

Beam loaded and supported as shown in [Fig. P-435](#). See the [instruction](#).

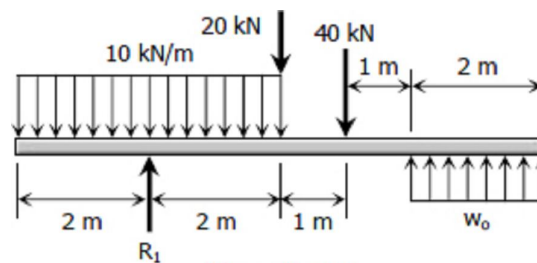

Figure P-435

Solution 435

$$\sum M_B = 0$$

$$2w_o(5) = 10(4)(0) + 20(2) + 40(3)$$

$$w_o = 16 \text{ kN/m}$$

$$\sum M_{\text{midpoint of } EF} = 0$$

$$5R_1 = 10(4)(5) + 20(3) + 40(2)$$

$$R_1 = 68 \text{ kN}$$

To draw the Shear Diagram

1. $M_A = 0$
2. $M_B = M_A + \text{Area in load diagram}$
 $M_B = 0 - 10(2) = -20 \text{ kN}$
 $M_{B2} + M_B + R_1 = -20 + 68 = 48 \text{ kN}$
3. $M_C = M_{B2} + \text{Area in load diagram}$
 $M_C = 48 - 10(2) = 28 \text{ kN}$
 $M_{C2} = M_C - 20 = 28 - 20 = 8 \text{ kN}$
4. $M_D = M_{C2} + \text{Area in load diagram}$
 $M_D = 8 + 0 = 8 \text{ kN}$
 $M_{D2} = M_D - 40 = 8 - 40 = -32 \text{ kN}$
5. $M_E = M_{D2} + \text{Area in load diagram}$
 $M_E = -32 + 0 = -32 \text{ kN}$
6. $M_F = M_E + \text{Area in load diagram}$
 $M_F = -32 + w_o(2)$
 $M_F = -32 + 16(2) = 0$

To draw the Moment Diagram

1. $M_A = 0$
2. $M_B = M_A + \text{Area in shear diagram}$
 $M_B = 0 - \frac{1}{2}(20)(2) = -20 \text{ kN}\cdot\text{m}$
3. $M_C = M_B + \text{Area in shear diagram}$
 $M_C = -20 + \frac{1}{2}(48 + 28)(2)$
 $M_C = 56 \text{ kN}\cdot\text{m}$
4. $M_D = M_C + \text{Area in shear diagram}$
 $M_D = 56 + 8(1) = 64 \text{ kN}\cdot\text{m}$
5. $M_E = M_D + \text{Area in shear diagram}$
 $M_E = 64 - 32(1) = 32 \text{ kN}\cdot\text{m}$
6. $M_F = M_E + \text{Area in shear diagram}$
 $M_F = 32 - \frac{1}{2}(32)(2) = 0$
7. The location and magnitude of moment at C' are determined from shear diagram. By squared property of parabola, $x = 0.44 \text{ m}$ from B.

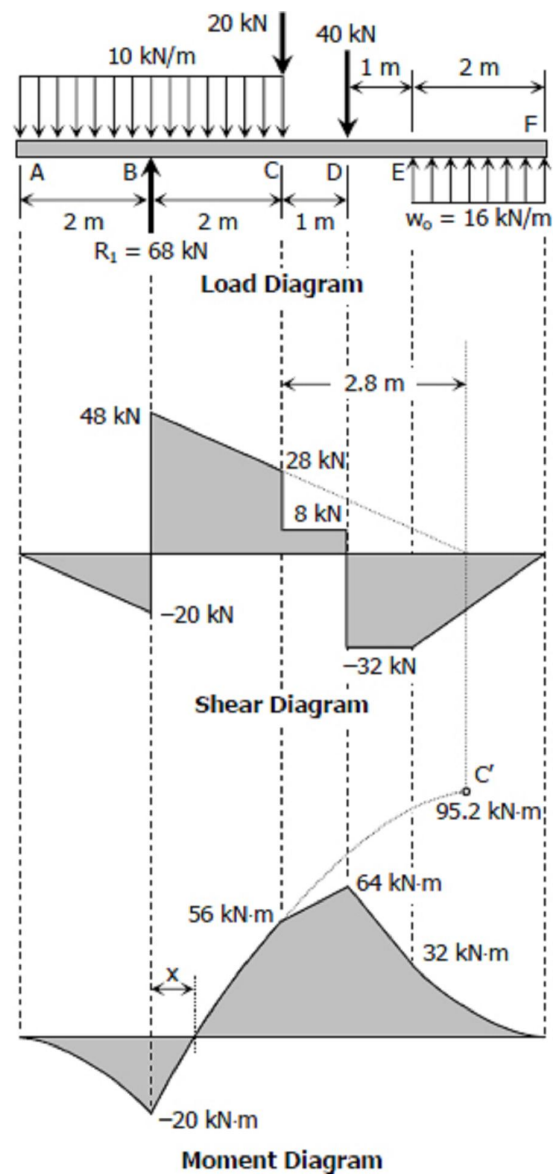

Solution to Problem 436 | Relationship Between Load, Shear, and Moment

A distributed load is supported by two distributed reactions as shown in Fig. P-436. See the [instruction](#).

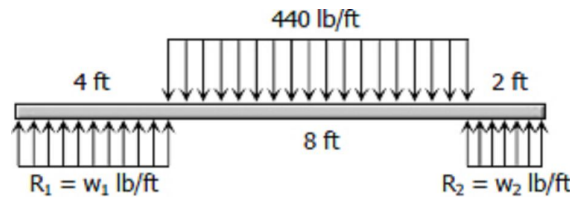

Figure P-436

Solution 436

$$\sum M_{\text{midpoint of } CD} = 0$$

$$4w_1(11) = 440(8)(5)$$

$$w_1 = 400 \text{ lb/ft}$$

$$\sum M_{\text{midpoint of } AB} = 0$$

$$2w_2(11) = 440(8)(6)$$

$$w_2 = 960 \text{ lb/ft}$$

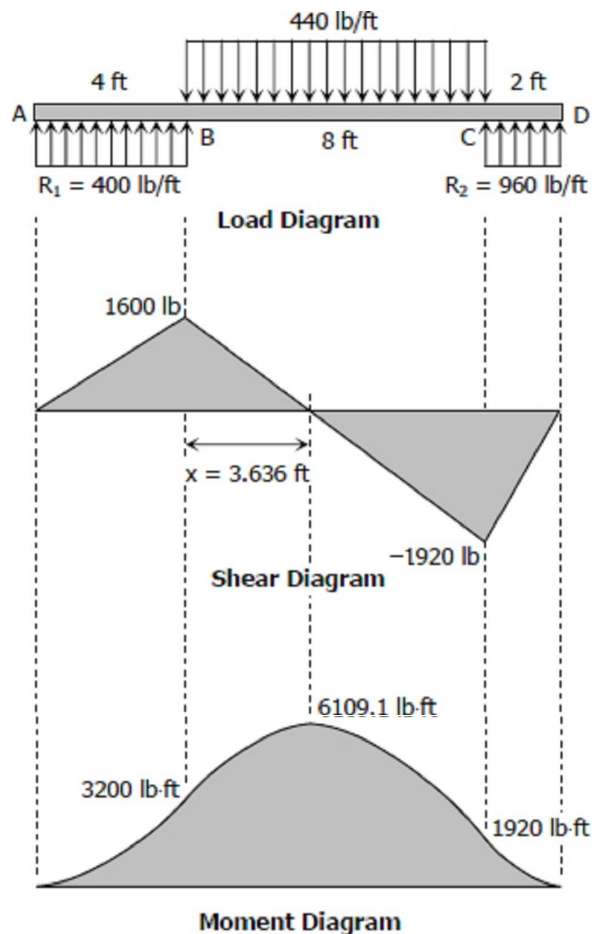

To draw the Shear Diagram

1. $V_A = 0$
2. $V_B = V_A + \text{Area in load diagram}$
 $V_B = 0 + 400(4) = 1600 \text{ lb}$
3. $V_C = V_B + \text{Area in load diagram}$
 $V_C = 1600 - 440(8) = -1920 \text{ lb}$
4. $V_D = V_C + \text{Area in load diagram}$
 $V_D = -1920 + 960(2) = 0$
5. **Location of zero shear:**
 $x / 1600 = (8 - x) / 1920$
 $x = 40/11 \text{ ft} = 3.636 \text{ ft from B}$

To draw the Moment Diagram

1. $M_A = 0$
2. $M_B = M_A + \text{Area in shear diagram}$

$$M_B = 0 + \frac{1}{2} (1600)(4) = 3200 \text{ lb}\cdot\text{ft}$$

$$3. M_x = M_B + \text{Area in shear diagram}$$

$$M_x = 3200 + \frac{1}{2} (1600)(40/11)$$

$$M_x = 6109.1 \text{ lb}\cdot\text{ft}$$

$$4. M_C = M_x + \text{Area in shear diagram}$$

$$M_C = 6109.1 - \frac{1}{2} (8 - 40/11)(1920)$$

$$M_C = 1920 \text{ lb}\cdot\text{ft}$$

$$5. M_D = M_C + \text{Area in shear diagram}$$

$$M_D = 1920 - \frac{1}{2} (1920)(2) = 0$$

Solution to Problem 437 | Relationship Between Load, Shear, and Moment

Cantilever beam loaded as shown in [Fig. P-437](#). See the [instruction](#)

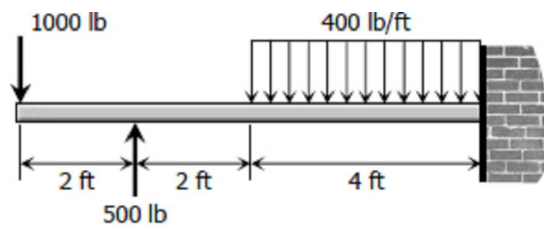
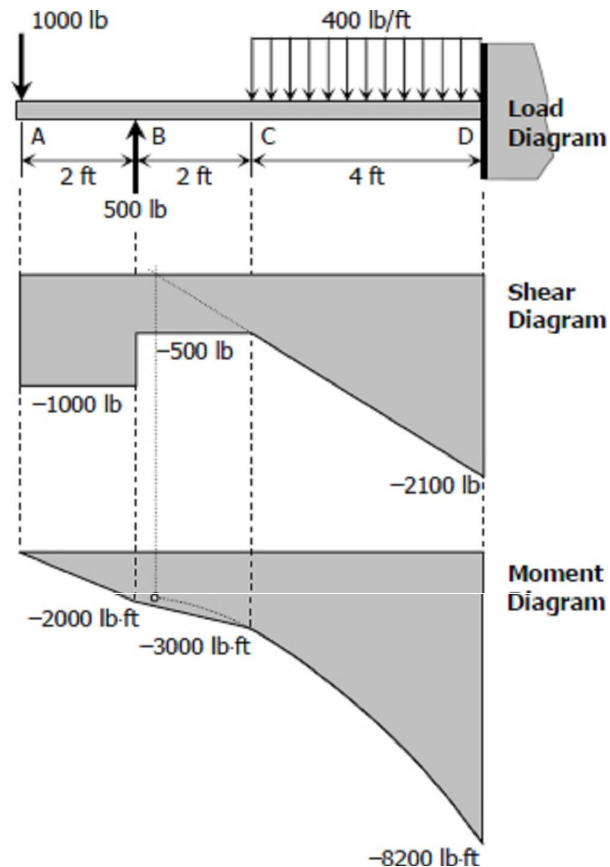

Figure P-437



Solution 437

To draw the Shear Diagram

$$1. V_A = -1000 \text{ lb}$$

$$2. V_B = V_A + \text{Area in load diagram}$$

$$V_B = -1000 + 0 = -1000 \text{ lb}$$

$$V_{B2} = V_B + 500 = -1000 + 500$$

$$V_{B2} = -500 \text{ lb}$$

$$3. V_C = V_{B2} + \text{Area in load diagram}$$

$$V_C = -500 + 0 = -500 \text{ lb}$$

$$4. V_D = V_C + \text{Area in load diagram}$$

$$V_D = -500 - 400(4) = -2100 \text{ lb}$$

To draw the Moment Diagram

1. $M_A = 0$
2. $M_B = M_A + \text{Area in shear diagram}$
 $M_B = 0 - 1000(2) = -2000 \text{ lb}\cdot\text{ft}$
3. $M_C = M_B + \text{Area in shear diagram}$
 $M_C = -2000 - 500(2) = -3000 \text{ lb}\cdot\text{ft}$
4. $M_D = M_C + \text{Area in shear diagram}$
 $M_D = -3000 - \frac{1}{2}(500 + 2100)(4)$
 $M_D = -8200 \text{ lb}\cdot\text{ft}$

Solution to Problem 438 | Relationship Between Load, Shear, and Moment

The beam loaded as shown in [Fig. P-438](#) consists of two segments joined by a frictionless hinge at which the bending moment is zero. See the [instruction](#).

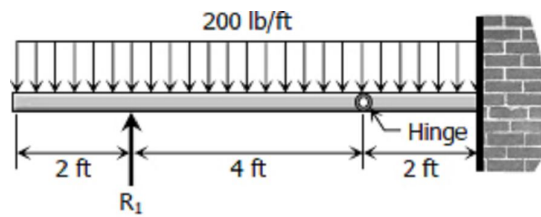
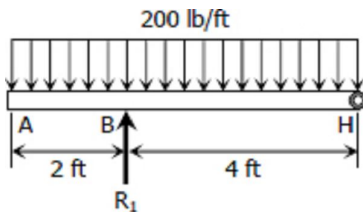

Figure P-438

Solution 438



$$\begin{aligned} \sum M_H &= 0 \\ 4R_1 &= 200(6)(3) \\ R_1 &= 900 \text{ lb} \end{aligned}$$

To draw the Shear Diagram

1. $V_A = 0$
2. $V_B = V_A + \text{Area in load diagram}$
 $V_B = 0 - 200(2) = -400 \text{ lb}$
 $V_{B2} = V_B + R_1 = -400 + 900 = 500 \text{ lb}$
3. $V_H = V_{B2} + \text{Area in load diagram}$
 $V_H = 500 - 200(4) = -300 \text{ lb}$

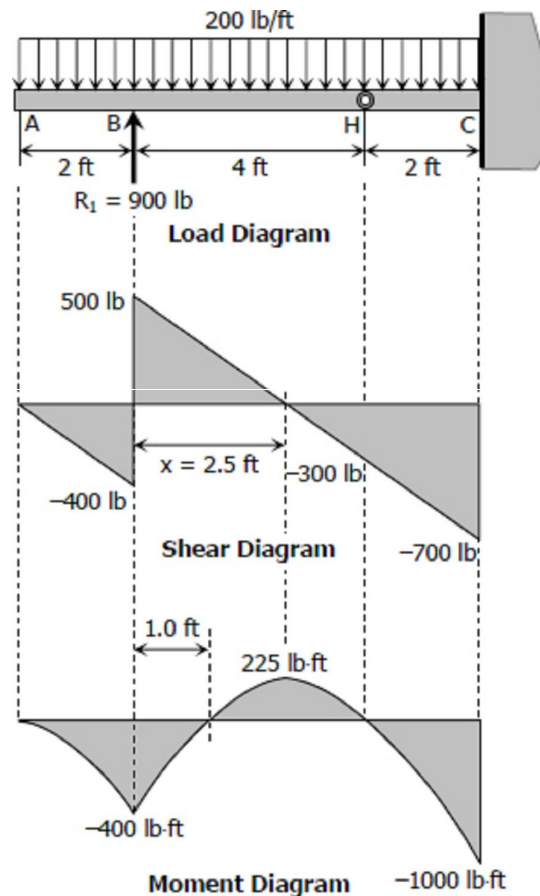

4. $V_C = V_H + \text{Area in load diagram}$
 $V_C = -300 - 200(2) = -700 \text{ lb}$
5. **Location of zero shear:**
 $x / 500 = (4 - x) / 300$
 $300x = 2000 - 500x$
 $x = 2.5 \text{ ft}$

To draw the Moment Diagram

1. $M_A = 0$
2. $M_B = M_A + \text{Area in shear diagram}$
 $M_B = 0 - \frac{1}{2}(400)(2) = -400 \text{ lb}\cdot\text{ft}$
3. $M_x = M_B + \text{Area in load diagram}$
 $M_x = -400 + \frac{1}{2}(500)(2.5)$
 $M_x = 225 \text{ lb}\cdot\text{ft}$
4. $M_H = M_x + \text{Area in load diagram}$
 $M_H = 225 - \frac{1}{2}(300)(4 - 2.5) = 0 \text{ ok!}$
5. $M_C = M_H + \text{Area in load diagram}$
 $M_C = 0 - \frac{1}{2}(300 + 700)(2)$
 $M_C = -1000 \text{ lb}\cdot\text{ft}$
6. The location of zero moment in segment BH can easily be found by symmetry.

Solution to Problem 439 | Relationship Between Load, Shear, and Moment

Problem 439

A beam supported on three reactions as shown in [Fig. P-439](#) consists of two segments joined by frictionless hinge at which the bending moment is zero. See the [instruction](#).

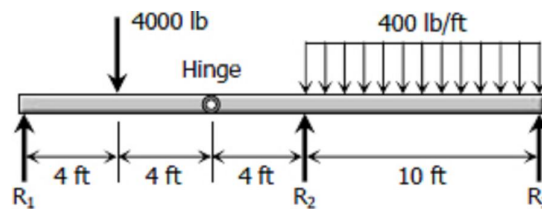
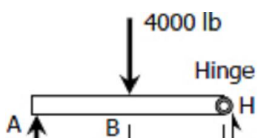

Figure P-439

Solution 439



$$\begin{aligned} \sum M_H &= 0 \\ 8R_1 &= 4000(4) \\ R_1 &= 2000 \text{ lb} \end{aligned}$$

$$\begin{aligned} \sum M_A = 0 \\ 8V_H = 4000(4) \\ V_H = 2000 \text{ lb} \end{aligned}$$

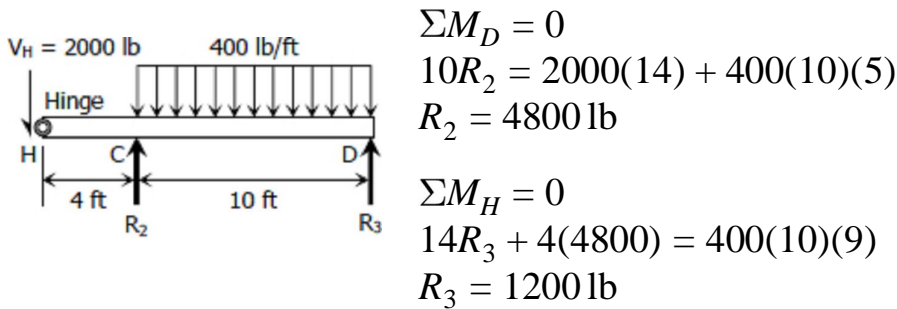

To draw the Shear Diagram

- $V_A = 0$
- $V_B = 2000 \text{ lb}$
 $V_{B2} = 2000 - 4000 = -2000 \text{ lb}$
- $V_H = -2000 \text{ lb}$
- $V_C = -2000 \text{ lb}$
 $V_C = -2000 + 4800 = 2800 \text{ lb}$
- $V_D = 2800 - 400(10) = -1200 \text{ lb}$
- Location of zero shear:**
 $x / 2800 = (10 - x) / 1200$
 $1200x = 28000 - 2800x$
 $x = 7 \text{ ft}$

To draw the Moment Diagram

- $M_A = 0$
- $M_B = 2000(4) = 8000 \text{ lb}\cdot\text{ft}$
- $M_H = 8000 - 4000(2) = 0$
- $M_C = -400(2)$
 $M_C = -800 \text{ lb}\cdot\text{ft}$
- $M_x = -800 + \frac{1}{2}(2800)(7)$
 $M_x = 1800 \text{ lb}\cdot\text{ft}$
- $M_D = 1800 - \frac{1}{2}(1200)(3)$
 $M_D = 0$
- Zero M is 4 ft from R_2

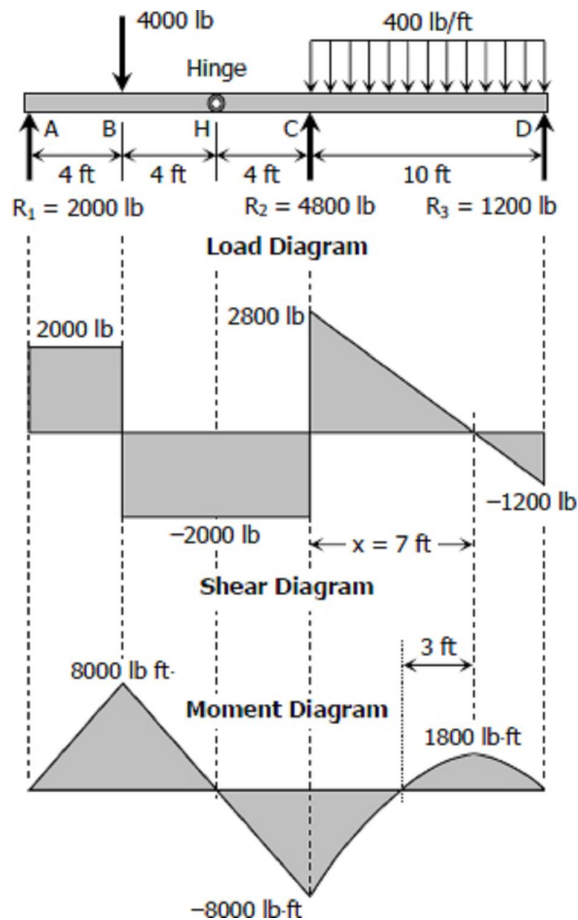

Solution to Problem 440 | Relationship Between

Load, Shear, and Moment

A frame ABCD, with rigid corners at B and C, supports the concentrated load as shown in [Fig. P-440](#). (Draw shear and moment diagrams for each of the three parts of the frame.) See the [instruction](#).

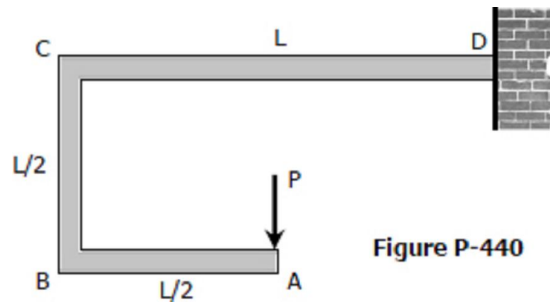
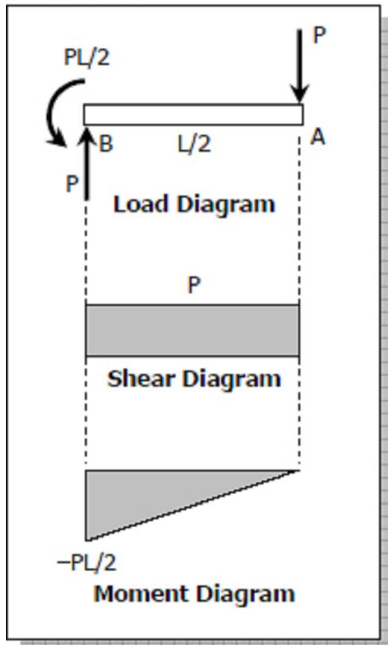
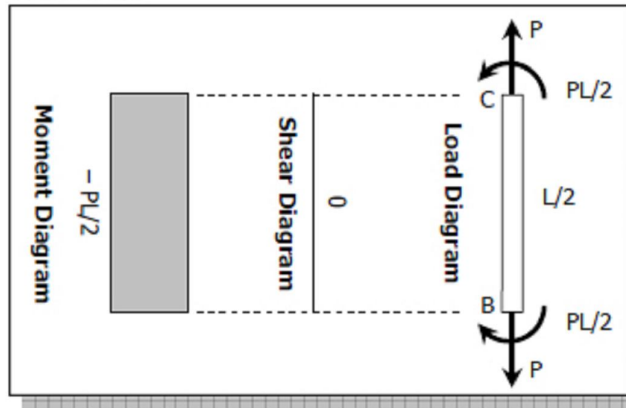
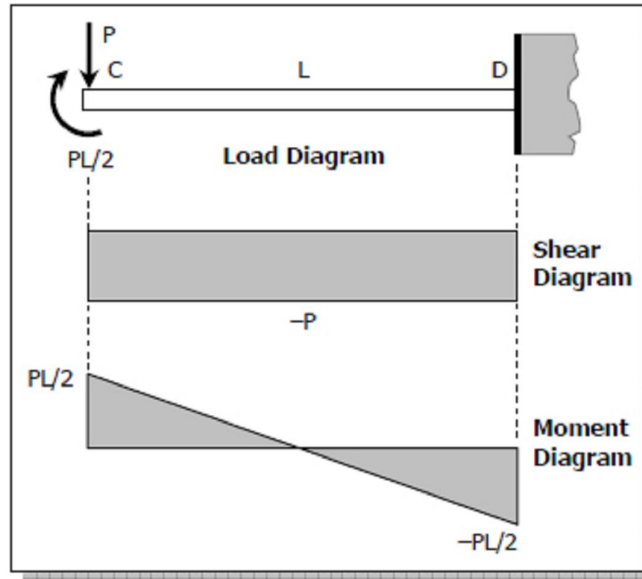

Figure P-440

Solution 440

Member AB**Member BC****Member CD**

Solution to Problem 441 | Relationship Between Load, Shear, and Moment

A beam ABCD is supported by a roller at A and a hinge at D. It is subjected to the loads shown in [Fig. P-441](#), which act at the ends of the vertical members BE and CF. These vertical members are rigidly attached to the beam at B and C. (Draw shear and moment diagrams for the beam ABCD only.) See the [instruction](#).

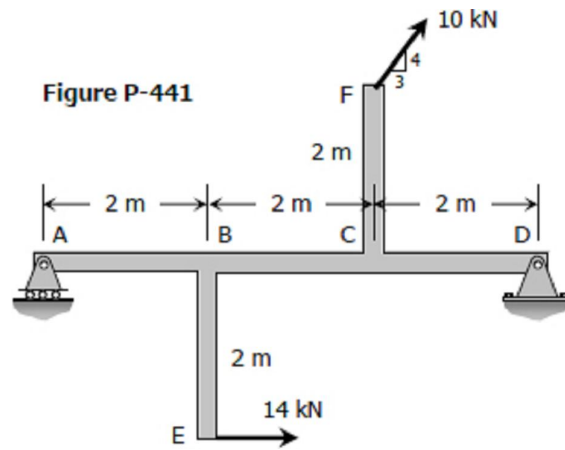

Solution 441

$$F_{BH} = 14 \text{ kN to the right}$$

$$M_B = 14(2)$$

$$M_B = 28 \text{ kN} \cdot \text{m counterclockwise}$$

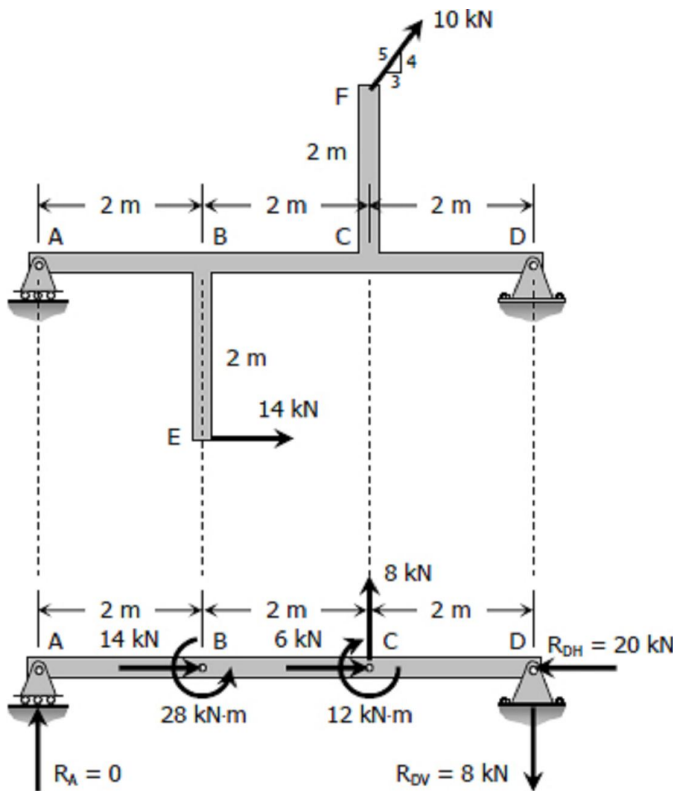

$$F_{CH} = \frac{3}{5}(10)$$

$$F_{CH} = 6 \text{ kN to the right}$$

$$F_{CV} = \frac{4}{5}(10)$$

$$F_{CV} = 8 \text{ kN upward}$$

$$M_C = F_{CH}(2) = 6(2)$$

$$M_C = 12 \text{ kN} \cdot \text{m clockwise}$$

$$\Sigma M_D = 0$$

$$6R_A + 12 + 8(2) = 28$$

$$R_A = 0$$

$$\Sigma M_A = 0$$

$$6R_{DV} + 12 = 28 + 8(4)$$

$$R_{DV} = 8 \text{ kN}$$

$$\Sigma F_H = 0$$

$$R_{DH} = 14 + 6$$

$$R_{DH} = 20 \text{ kN}$$

To draw the Shear Diagram

1. Shear in segments AB and BC is zero.
2. $V_C = 8$
3. $V_D = V_C + \text{Area in load diagram}$
 $V_D = 8 + 0 = 8 \text{ kN}$
 $V_{D2} = V_D - R_{DV}$
 $V_{D2} = 8 - 8 = 0$

To draw the Moment Diagram

1. Moment in segment AB is zero
2. $M_B = -28 \text{ kN}\cdot\text{m}$
3. $M_C = M_B + \text{Area in shear diagram}$
 $M_C = -28 + 0 = -28 \text{ kN}\cdot\text{m}$
 $M_{C2} = M_C + 12 = -28 + 12$
 $M_{C2} = -16 \text{ kN}\cdot\text{m}$
4. $M_D = M_{C2} + \text{Area in shear diagram}$
 $M_D = -16 + 8(2)$
 $M_D = 0$

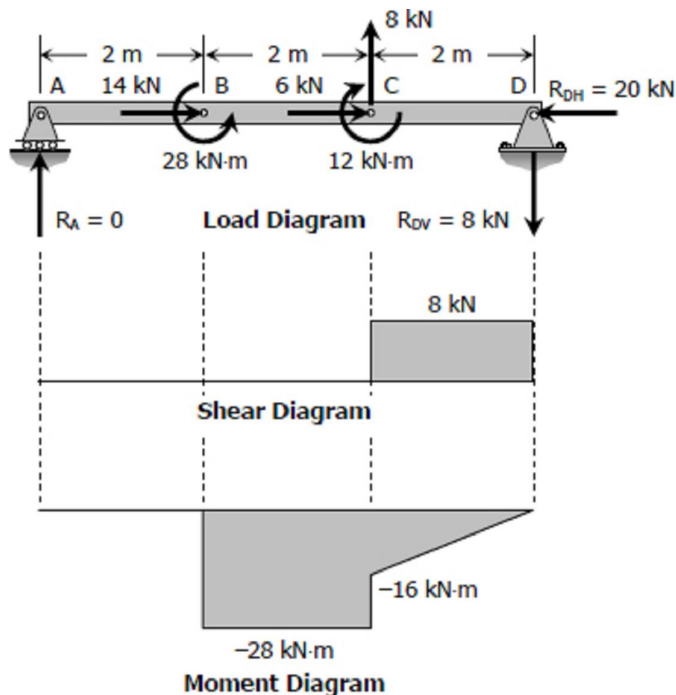

Solution to Problem 442 | Relationship Between Load, Shear, and Moment

Beam carrying the uniformly varying load shown in [Fig. P-442](#). See the [instruction](#).

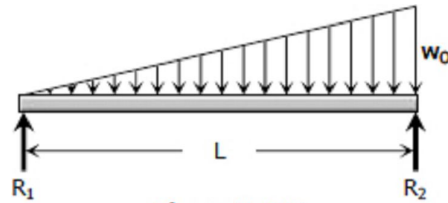
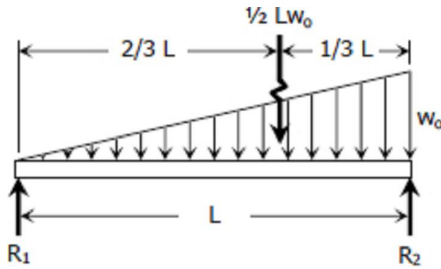

Figure P-442

Solution 442



$$\begin{aligned}\sum M_{R2} &= 0 \\ LR_1 &= \frac{1}{3}L \left(\frac{1}{2}Lw_0\right) \\ R_1 &= \frac{1}{6}Lw_0\end{aligned}$$

$$\begin{aligned}\sum M_{R1} &= 0 \\ LR_2 &= \frac{2}{3}L \left(\frac{1}{2}Lw_0\right)\end{aligned}$$

$$R_2 = \frac{1}{3}Lw_0$$

To draw the Shear Diagram

- $V_A = R_1 = 1/6 Lw_0$
- $V_B = V_A + \text{Area in load diagram}$
 $V_B = 1/6 Lw_0 - 1/2 Lw_0$
 $V_B = -1/3 Lw_0$
- Location of zero shear C:**
 By squared property of parabola:
 $x^2 / (1/6 Lw_0) = L^2 / (1/6 Lw_0 + 1/3 Lw_0)$
 $6x^2 = 2L^2$
 $x = L / \sqrt{3}$
- The shear in AB is a parabola with vertex at A, the starting point of uniformly varying load. The load in AB is 0 at A to downward w_0 or $-w_0$ at B, thus the slope of shear diagram is decreasing. For decreasing slope, the parabola is open downward.

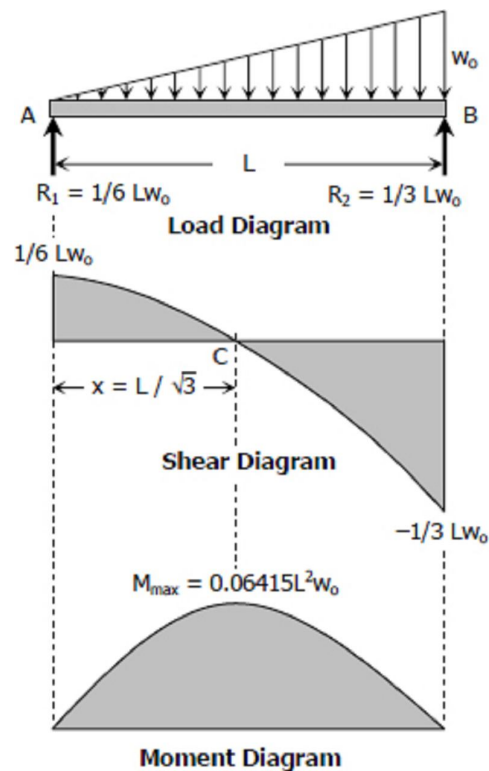

To draw the Moment Diagram

- $M_A = 0$
- $M_C = M_A + \text{Area in shear diagram}$
 $M_C = 0 + 2/3 (L/\sqrt{3})(1/6 Lw_0)$
 $M_C = 0.06415 L^2 w_0 = M_{\max}$
- $M_B = M_C + \text{Area in shear diagram}$

$$M_B = M_C - A_1 \text{ (see figure for solving } A_1\text{)}$$

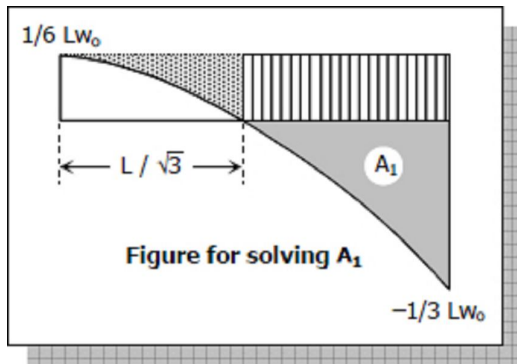

For A_1 :

$$A_1 = \frac{1}{3} L \left(\frac{1}{6} L w_0 + \frac{1}{3} L w_0 \right) - \frac{1}{3} \left(\frac{L}{\sqrt{3}} \right) \left(\frac{1}{6} L w_0 \right) - \frac{1}{6} L w_0 \left(L - \frac{L}{\sqrt{3}} \right)$$

$$A_1 = 0.16667L^2 w_0 - 0.03208L^2 w_0 - 0.07044L^2 w_0$$

$$A_1 = 0.06415L^2 w_0$$

$$M_B = 0.06415L^2 w_0 - 0.06415L^2 w_0 = 0$$

4. The shear diagram is second degree curve, thus the moment diagram is a third degree curve. The maximum moment (highest point) occurred at C, the location of zero shear. The value of shears in AC is positive then the moment in AC is increasing; at CB the shear is negative, then the moment in CB is decreasing.

Solution to Problem 443 | Relationship Between Load, Shear, and Moment

Beam carrying the triangular loads shown in [Fig. P-443](#). See the [instruction](#).

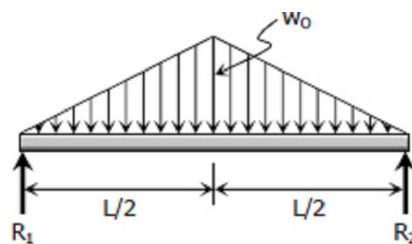

Figure P-443

Solution 443

By symmetry:

$$R_1 = R_2 = \frac{1}{2} \left(\frac{1}{2} L w_0 \right)$$

$$R_1 = R_2 = \frac{1}{4} L w_0$$

To draw the Shear Diagram

1. $V_A = R_1 = \frac{1}{4} L w_0$
2. $V_B = V_A + \text{Area in load diagram}$
 $V_B = \frac{1}{4} L w_0 - \frac{1}{2} (L/2)(w_0) = 0$
3. $V_C = V_B + \text{Area in load diagram}$
 $V_C = 0 - \frac{1}{2} (L/2)(w_0) = -\frac{1}{4} L w_0$
4. Load in AB is linear, thus, V_{AB} is second degree or parabolic curve. The load is from 0 at A to w_0 (w_0 is downward or $-w_0$) at B, thus the slope of V_{AB} is decreasing.
5. V_{BC} is also parabolic since the load in BC is linear. The magnitude of load in BC is from $-w_0$ to 0 or increasing, thus the slope of V_{BC} is increasing.

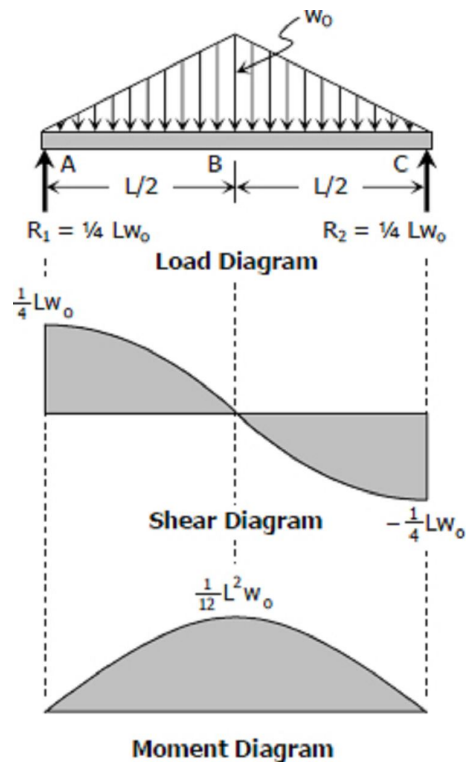

To draw the Moment Diagram

1. $M_A = 0$
2. $M_B = M_A + \text{Area in shear diagram}$
 $M_B = 0 + \frac{2}{3} (L/2) \left(\frac{1}{4} L w_0 \right) = \frac{1}{12} L w_0$
3. $M_C = M_B + \text{Area in shear diagram}$
 $M_C = \frac{1}{12} L w_0 - \frac{2}{3} (L/2) \left(\frac{1}{4} L w_0 \right) = 0$
4. M_{AC} is third degree because the shear diagram in AC is second degree.
5. The shear from A to C is decreasing, thus the slope of moment diagram from A to C is decreasing.

Solution to Problem 444 | Relationship Between Load, Shear, and Moment

Beam loaded as shown in [Fig. P-444](#). See the [instruction](#).

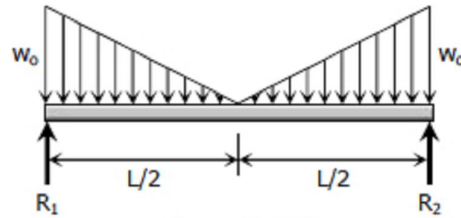

Figure P-444

Solution 444

$$\text{Total load} = 2 \left[\frac{1}{2} (L/2) (w_0) \right]$$

$$\text{Total load} = \frac{1}{2} L w_0$$

By symmetry

$$R_1 = R_2 = \frac{1}{2} \times \text{Total load}$$

$$R_1 = R_2 = \frac{1}{4} L w_0$$

To draw the Shear Diagram

- $V_A = R_1 = \frac{1}{4} L w_0$
- $V_B = V_A + \text{Area in load diagram}$
 $V_B = \frac{1}{4} L w_0 - \frac{1}{2} (L/2) (w_0) = 0$
- $V_C = V_B + \text{Area in load diagram}$
 $V_C = 0 - \frac{1}{2} (L/2) (w_0) = -\frac{1}{4} L w_0$
- The shear diagram in AB is second degree curve. The shear in AB is from $-w_0$ (downward w_0) to zero or increasing, thus, the slope of shear at AB is increasing (upward parabola).
- The shear diagram in BC is second degree curve. The shear in BC is from zero to $-w_0$ (downward w_0) or decreasing, thus, the slope of shear at BC is decreasing (downward parabola)

To draw the Moment Diagram

- $M_A = 0$
- $M_B = M_A + \text{Area in shear diagram}$
 $M_B = 0 + \frac{1}{3} (L/2) (\frac{1}{4} L w_0) = \frac{1}{24} L^2 w_0$
- $M_C = M_B + \text{Area in shear diagram}$
 $M_C = \frac{1}{24} L^2 w_0 - \frac{1}{3} (L/2) (\frac{1}{4} L w_0) = 0$
- The shear diagram from A to C is decreasing, thus, the moment diagram is a concave downward third degree curve.

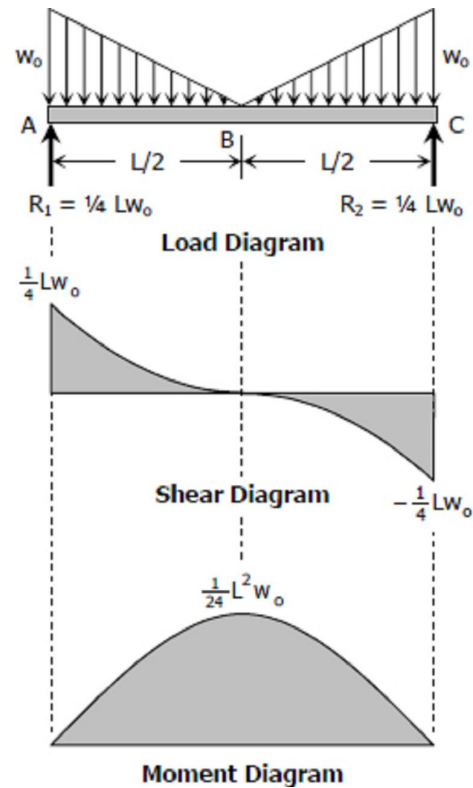

Solution to Problem 445 | Relationship Between Load, Shear, and Moment

Problem 445

Beam carrying the loads shown in [Fig. P-445](#). See the [instruction](#).

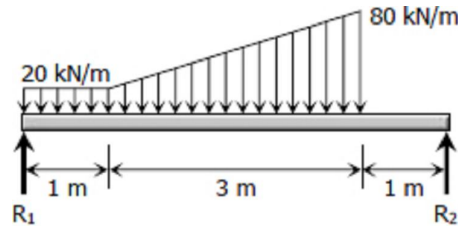
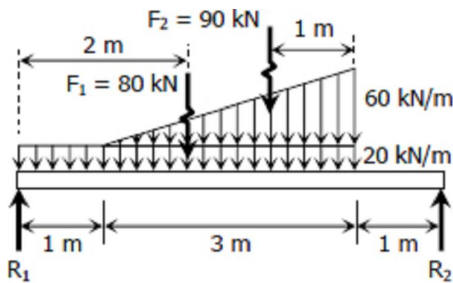

Figure P-445

Solution 445



$$\begin{aligned} \sum M_{R2} &= 0 \\ 5R_1 &= 80(3) + 90(2) \\ R_1 &= 84 \text{ kN} \end{aligned}$$

$$\begin{aligned} \sum M_{R1} &= 0 \\ 5R_2 &= 80(2) + 90(3) \\ R_2 &= 86 \text{ kN} \end{aligned}$$

Checking

$$R_1 + R_2 = F_1 + F_2 \quad \text{ok!}$$

To draw the Shear Diagram

1. $V_A = R_1 = 84 \text{ kN}$
2. $V_B = V_A + \text{Area in load diagram}$
 $V_B = 84 - 20(1) = 64 \text{ kN}$
3. $V_C = V_B + \text{Area in load diagram}$

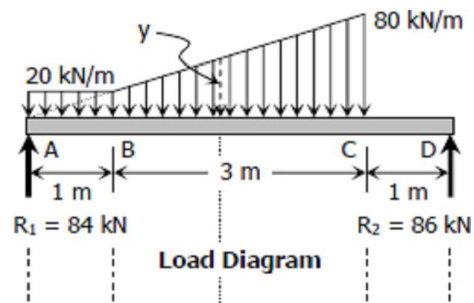

$$V_C = 64 - \frac{1}{2} (20 + 80)(3) = -86 \text{ kN}$$

$$4. V_D = V_C + \text{Area in load diagram}$$

$$V_D = -86 + 0 = -86 \text{ kN}$$

$$V_{D2} = V_D + R_2 = -86 + 86 = 0$$

5. **Location of zero shear:**

From the load diagram:

$$y / (x + 1) = 80 / 4$$

$$y = 20(x + 1)$$

$$V_E = V_B + \text{Area in load diagram}$$

$$0 = 64 - \frac{1}{2} (20 + y)x$$

$$(20 + y)x = 128$$

$$[20 + 20(x + 1)]x = 128$$

$$20x^2 + 40x - 128 = 0$$

$$5x^2 + 10x - 32 = 0$$

$$x = 1.72 \text{ and } -3.72$$

use $x = 1.72 \text{ m}$ from B

6. By squared property of parabola:

$$z / (1 + x)^2 = (z + 86) / 4^2$$

$$16z = 7.3984z + 636.2624$$

$$8.6016z = 254.4224$$

$$z = 73.97 \text{ kN}$$

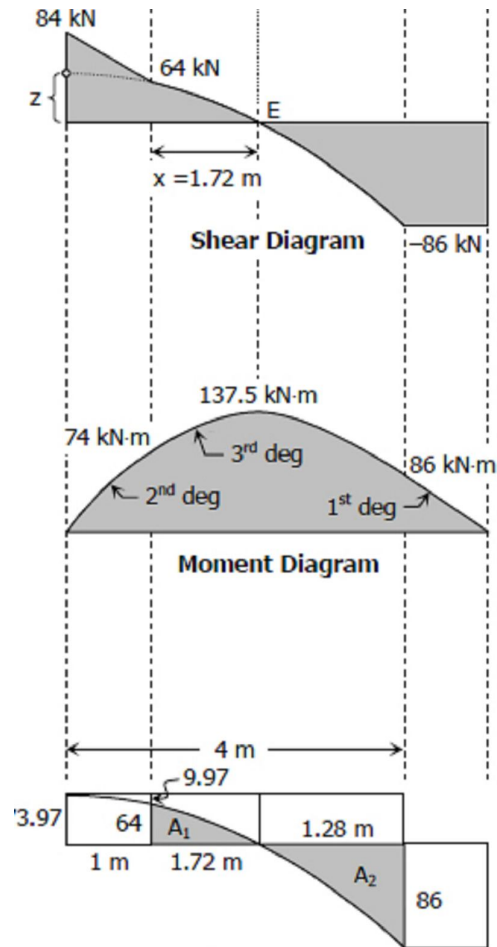

Figure for solving A_1 and A_2

To draw the Moment Diagram

$$1. M_A = 0$$

$$2. M_B = M_A + \text{Area in shear diagram}$$

$$M_B = 0 + \frac{1}{2} (84 + 64)(1) = 74 \text{ kN}\cdot\text{m}$$

$$3. M_E = M_B + \text{Area in shear diagram}$$

$$M_E = 74 + A_1 \text{ (see figure for } A_1 \text{ and } A_2)$$

For A_1 :

$$A_1 = \frac{2}{3} (1 + 1.72)(73.97) - 64(1) - \frac{2}{3} (1)(9.97)$$

$$A_1 = 63.5$$

$$M_E = 74 + 63.5 = 137.5 \text{ kN}\cdot\text{m}$$

$$4. M_C = M_E + \text{Area in shear diagram}$$

$$M_C = M_E - A_2$$

For A_2 :

$$A_2 = \frac{1}{3} (4)(73.97 + 86) - \frac{1}{3} (1 + 1.72)(73.97) - 1.28(73.97)$$

$$A_2 = 51.5$$

$$M_C = 137.5 - 51.5 = 86 \text{ kN}\cdot\text{m}$$

5. $M_D = M_C + \text{Area in shear diagram}$
 $M_D = 86 - 86(1) = 0$

Solution to Problem 446 | Relationship Between Load, Shear, and Moment

Beam loaded and supported as shown in [Fig. P-446](#). See the [instruction](#).

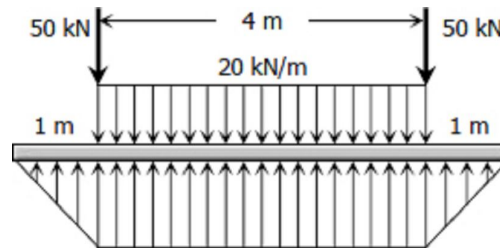

Figure P-446

Solution 446

$$\sum F_V = 0$$

$$4w_o + 2 \left[\frac{1}{2} w_o(1) \right] = 20(4) + 2(50)$$

$$5w_o = 180$$

$$w_o = 36 \text{ kN/m}$$

To draw the Shear Diagram

- $V_A = 0$
- $V_B = V_A + \text{Area in load diagram}$
 $V_B = 0 + \frac{1}{2} (36)(1) = 18 \text{ kN}$
 $V_{B2} = V_B - 50 = 18 - 50$
 $V_{B2} = -32 \text{ kN}$
- The net uniformly distributed load in segment BC is $36 - 20 = 16 \text{ kN/m}$ upward.
 $V_C = V_{B2} + \text{Area in load diagram}$
 $V_C = -32 + 16(4) = 32 \text{ kN}$

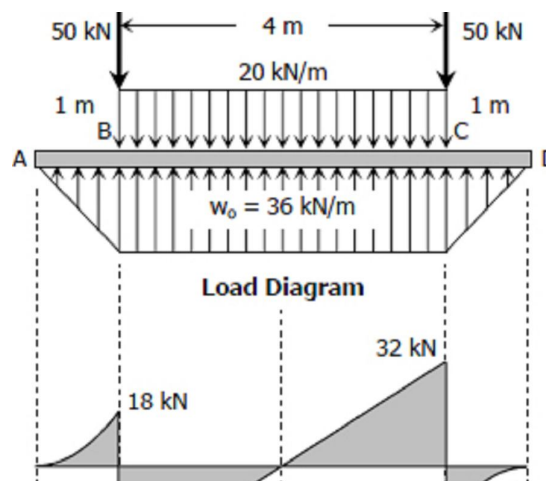

$$V_{C2} = V_C - 50 = 32 - 50$$

$$V_{C2} = -18 \text{ kN}$$

$$4. V_D = V_{C2} + \text{Area in load diagram}$$

$$V_D = -18 + \frac{1}{2} (36)(1) = 0$$

5. The shape of shear at AB and CD are parabolic spandrel with vertex at A and D, respectively.

6. The location of zero shear is obviously at the midspan or 2 m from B.

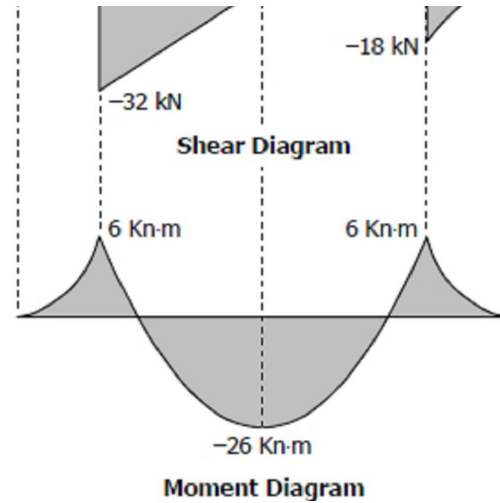

To draw the Moment Diagram

$$1. M_A = 0$$

$$2. M_B = M_A + \text{Area in shear diagram}$$

$$M_B = 0 + \frac{1}{3} (1)(18)$$

$$M_B = 6 \text{ kN}\cdot\text{m}$$

$$3. M_{\text{midspan}} = M_B + \text{Area in shear diagram}$$

$$M_{\text{midspan}} = 6 - \frac{1}{2} (32)(2)$$

$$M_{\text{midspan}} = -26 \text{ kN}\cdot\text{m}$$

$$4. M_C = M_{\text{midspan}} + \text{Area in shear diagram}$$

$$M_C = -26 + \frac{1}{2} (32)(2)$$

$$M_C = 6 \text{ kN}\cdot\text{m}$$

$$5. M_D = M_C + \text{Area in shear diagram}$$

$$M_D = 6 - \frac{1}{3} (1)(18) = 0$$

6. The moment diagram at AB and CD are 3rd degree curve while at BC is 2nd degree curve.

Load and moment diagrams for a given shear diagram

Instruction:

In the following problems, draw moment and load diagrams corresponding to the given shear diagrams. Specify values at all change of load positions and at all points of zero shear.

Solution to Problem 447 | Relationship Between Load, Shear, and Moment

Shear diagram as shown in [Fig. P-447](#). See the [instruction](#).

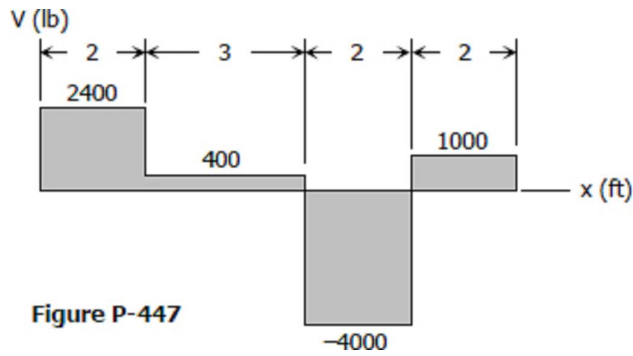

Figure P-447

Solution 447

To draw the Load Diagram

1. A 2400 lb upward force is acting at point A. No load in segment AB.
2. A point force of $2400 - 400 = 2000$ lb is acting downward at point B. No load in segment BC.
3. Another downward force of magnitude $400 + 4000 = 4400$ lb at point C. No load in segment CD.
4. Upward point force of $4000 + 1000 = 5000$ lb is acting at D. No load in segment DE.
5. A downward force of 1000 lb is concentrated at point E.

To draw the Moment Diagram

1. $M_A = 0$
2. $M_B = M_A + \text{Area in shear diagram}$
 $M_B = 0 + 2400(2) = 4800$ lb·ft
 M_{AB} is linear and upward
3. $M_C = M_B + \text{Area in shear diagram}$
 $M_C = 4800 + 400(3) = 6000$ lb·ft
 M_{BC} is linear and upward
4. $M_D = M_C + \text{Area in shear diagram}$
 $M_D = 6000 - 4000(2) = -2000$ lb·ft
 M_{CD} is linear and downward
5. $M_E = M_D + \text{Area in shear diagram}$
 $M_E = -2000 + 1000(2) = 0$
 M_{DE} is linear and upward

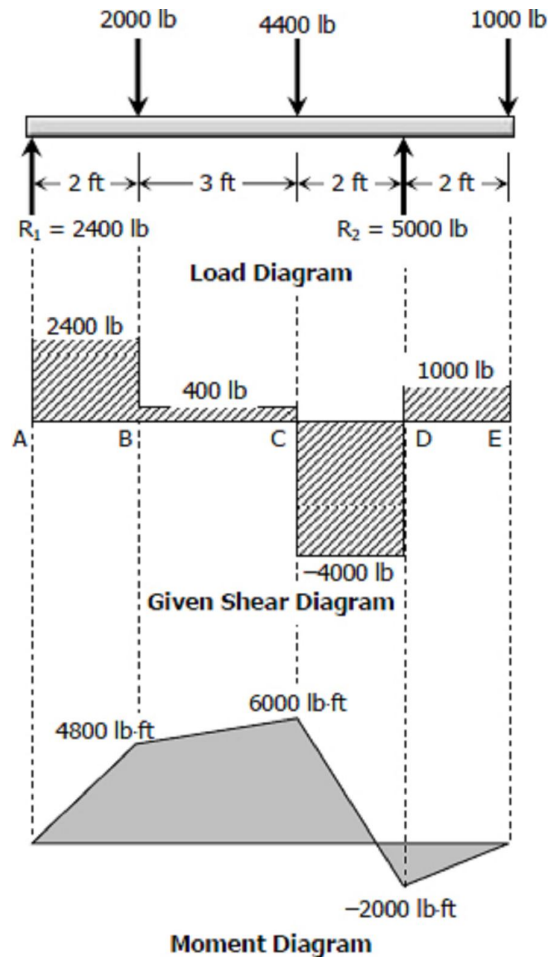

Solution to Problem 448 | Relationship Between Load, Shear, and Moment

Problem 448

Shear diagram as shown in [Fig. P-448](#). See the [instruction](#).

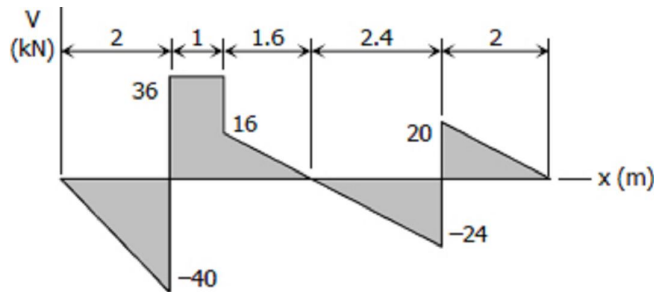
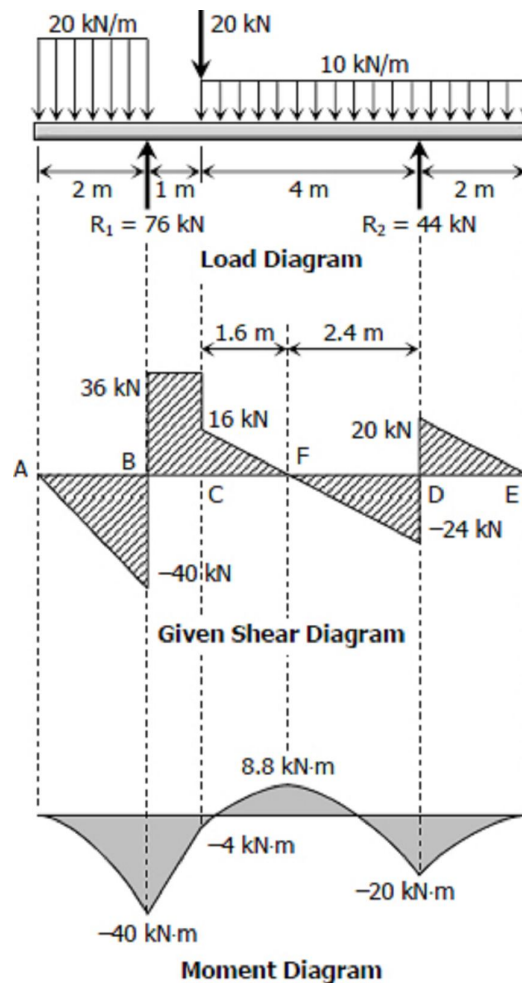

Figure P-448

To draw the Load Diagram

1. A uniformly distributed load in AB is acting downward at a magnitude of $40/2 = 20 \text{ kN/m}$.
2. Upward concentrated force of $40 + 36 = 76 \text{ kN}$ acts at B. No load in segment BC.
3. A downward point force acts at C at a magnitude of $36 - 16 = 20 \text{ kN}$.
4. Downward uniformly distributed load in CD has a magnitude of $(16 + 24)/4 = 10 \text{ kN/m}$ & causes zero shear at point F, 1.6 m from C.
5. Another upward concentrated force acts at D at a magnitude of $20 + 24 = 44 \text{ kN}$.
6. The load in segment DE is uniform and downward at $20/2 = 10 \text{ kN/m}$.



To draw the Moment Diagram

1. $M_A = 0$
2. $M_B = M_A + \text{Area in shear diagram}$
 $M_B = 0 - \frac{1}{2} (40)(2) = -40 \text{ kN}\cdot\text{m}$
 M_{AB} is downward parabola with vertex at A.
3. $M_C = M_B + \text{Area in shear diagram}$
 $M_C = -40 + 36(1) = -4 \text{ kN}\cdot\text{m}$
 M_{BC} is linear and upward
4. $M_F = M_C + \text{Area in shear diagram}$
 $M_F = -4 + \frac{1}{2} (16)(1.6) = 8.8 \text{ kN}\cdot\text{m}$
5. $M_D = M_F + \text{Area in shear diagram}$
 $M_D = 8.8 - \frac{1}{2} (24)(2.4) = -20 \text{ kN}\cdot\text{m}$
 M_{CD} is downward parabola with vertex at F.
6. $M_E = M_D + \text{Area in shear diagram}$
 $M_E = -20 + \frac{1}{2} (20)(2) = 0$
 M_{DE} is downward parabola with vertex at E.

Solution to Problem 449 | Relationship Between Load, Shear, and Moment

Shear diagram as shown in [Fig. P-449](#). See the [instruction](#).

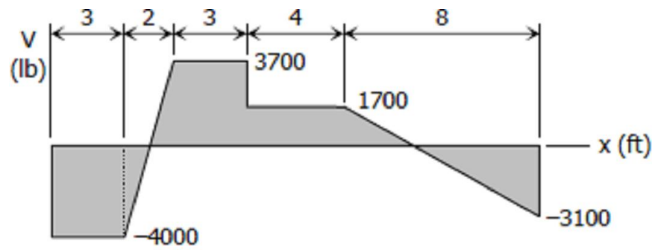

Figure P-449

Solution 449

To draw the Load Diagram

1. Downward 4000 lb force is concentrated at A and no load in segment AB.
2. The shear in BC is uniformly increasing, thus a uniform upward force is acting at a magnitude of $(3700 + 4000)/2 = 3850$ lb/ft. No load in segment CD.
3. Another point force acting downward with $3700 - 1700 = 1200$ lb at D and no load in segment DE.
4. The shear in EF is uniformly decreasing, thus a uniform downward force is acting with magnitude of $(1700 + 3100)/8 = 600$ lb/ft.
5. Upward force of 3100 lb is concentrated at end of span F.

To draw the Moment Diagram

1. The locations of zero shear (points G and H) can be easily determined by ratio and proportion of triangle.
2. $M_A = 0$; $M_B = M_A + \text{Area in shear diagram}$
 $M_B = 0 - 4000(3) = -12,000$ lb-ft

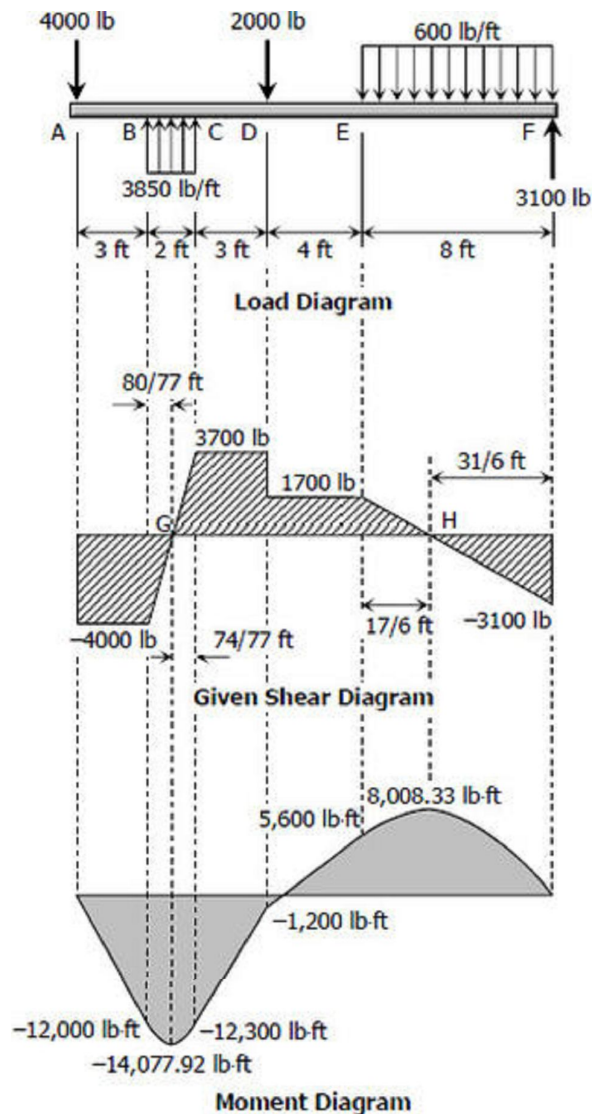

3. $M_G = M_B + \text{Area in shear diagram}$
 $M_G = -12,000 - \frac{1}{2} (80/77)(4000)$
 $M_G = -14,077.92 \text{ lb}\cdot\text{ft}$
4. $M_C = M_G + \text{Area in shear diagram}$
 $M_C = -14,077.92 + \frac{1}{2} (74/77)(3700)$
 $M_C = -12,300 \text{ lb}\cdot\text{ft}$
5. $M_D = M_C + \text{Area in shear diagram}$
 $M_D = -12,300 + 3700(3) = -1200 \text{ lb}\cdot\text{ft}$
6. $M_E = M_D + \text{Area in shear diagram}$
 $M_E = -1200 + 1700(4) = 5600 \text{ lb}\cdot\text{ft}$
7. $M_H = M_E + \text{Area in shear diagram}$
 $M_H = 5600 + \frac{1}{2} (17/6)(1700)$
 $M_H = 8,008.33 \text{ lb}\cdot\text{ft}$
8. $M_F = M_H + \text{Area in shear diagram}$
 $M_F = 8,008.33 - \frac{1}{2} (31/6)(3100) = 0$

Solution to Problem 450 | Relationship Between Load, Shear, and Moment

Shear diagram as shown in [Fig. P-450](#). See the [instruction](#).

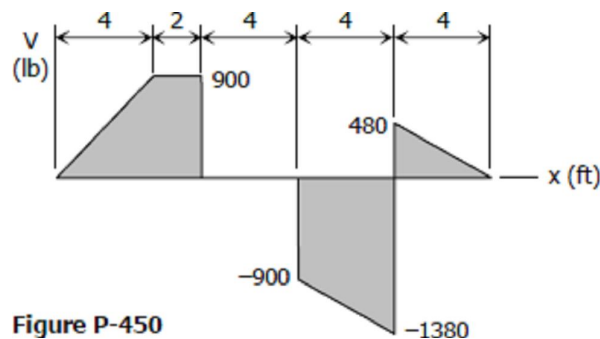

Solution 450

To draw the Load Diagram

1. The shear diagram in AB is uniformly upward, thus the load is uniformly distributed upward at a magnitude of $900/4 = 225 \text{ lb/ft}$. No load in segment BC.
2. A downward point force acts at point C with

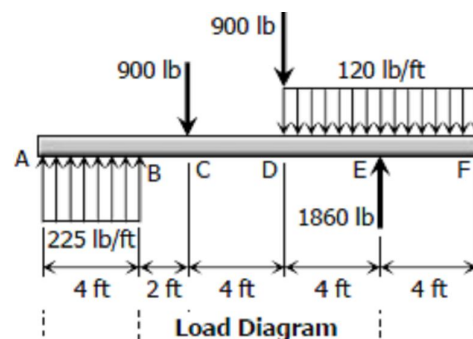

magnitude of 900 lb. No load in segment CD.

- Another concentrated force is acting downward at D with a magnitude of 900 lb.
- The load in DE is uniformly distributed downward at a magnitude of $(1380 - 900)/4 = 120$ lb/ft.
- An upward load is concentrated at E with magnitude of $480 + 1380 = 1860$ lb.
- $480/4 = 120$ lb/ft is distributed uniformly over the span EF.

To draw the Moment Diagram

- $M_A = 0$
- $M_B = M_A + \text{Area in shear diagram}$
 $M_B = 0 + \frac{1}{2} (4)(900) = 1800$ lb·ft
- $M_C = M_B + \text{Area in shear diagram}$
 $M_C = 1800 + 900(2) = 3600$ lb·ft
- $M_D = M_C + \text{Area in shear diagram}$
 $M_D = 3600 + 0 = 3600$ lb·ft
- $M_E = M_D + \text{Area in shear diagram}$
 $M_E = 3600 - \frac{1}{2} (900 + 1380)(4)$
 $M_E = -960$ lb·ft
- $M_F = M_E + \text{Area in shear diagram}$
 $M_F = -960 + \frac{1}{2} (480)(4) = 0$
- The shape of moment diagram in AB is upward parabola with vertex at A, while linear in BC and horizontal in CD. For segment DE, the diagram is downward parabola with vertex at G. G is the point where the extended shear in DE intersects the line of zero shear.
- The moment diagram in EF is a downward parabola with vertex at F.

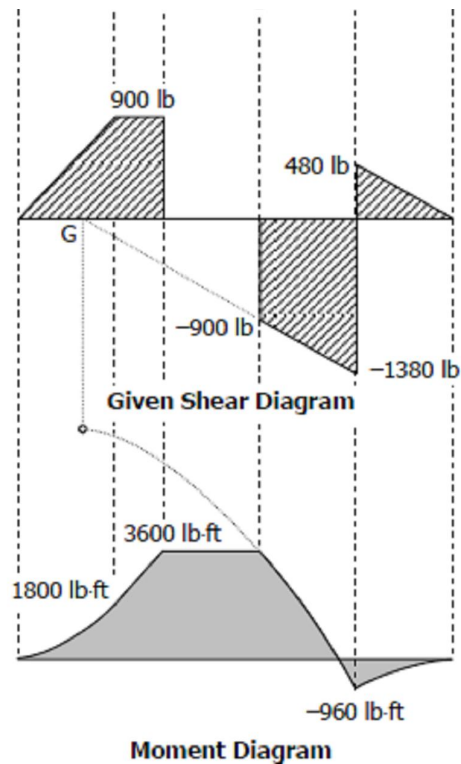

Solution to Problem 451 | Relationship Between Load, Shear, and Moment

Shear diagram as shown in [Fig. P-451](#). See the [instruction](#).

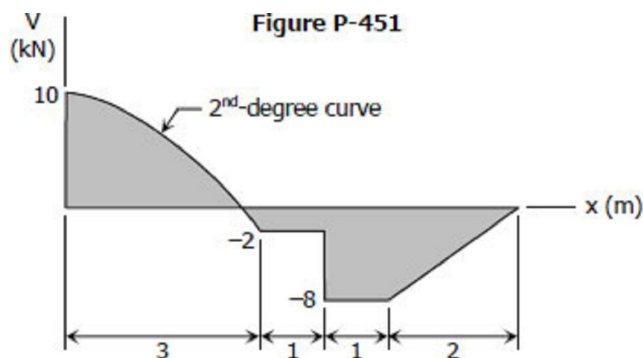

To draw the Load Diagram

1. Upward concentrated load at A is 10 kN.
2. The shear in AB is a 2nd-degree curve, thus the load in AB is uniformly varying. In this case, it is zero at A to $2(10 + 2)/3 = 8$ kN at B. No load in segment BC.
3. A downward point force is acting at C in a magnitude of $8 - 2 = 6$ kN.
4. The shear in DE is uniformly increasing, thus the load in DE is uniformly distributed and upward. This load is spread over DE at a magnitude of $8/2 = 4$ kN/m.

To draw the Moment Diagram

1. To find the location of zero shear, F:

$$x^2/10 = 3^2/(10 + 2)$$

$$x = 2.74 \text{ m}$$
2. $M_A = 0$
3. $M_F = M_A + \text{Area in shear diagram}$
 $M_F = 0 + 2/3 (2.74)(10) = 18.26 \text{ kN}\cdot\text{m}$
4. $M_B = M_F + \text{Area in shear diagram}$
 $M_B = 18.26 - [1/3 (10 + 2)(3) - 1/3 (2.74)(10) - 10(3 - 2.74)]$
 $M_B = 18 \text{ kN}\cdot\text{m}$
5. $M_C = M_B + \text{Area in shear diagram}$
 $M_C = 18 - 2(1) = 16 \text{ kN}\cdot\text{m}$
6. $M_D = M_C + \text{Area in shear diagram}$
 $M_D = 16 - 8(1) = 8 \text{ kN}\cdot\text{m}$
7. $M_E = M_D + \text{Area in shear diagram}$
 $M_E = 8 - \frac{1}{2} (2)(8) = 0$
8. The moment diagram in AB is a second degree curve, at BC and CD are linear and downward. For segment DE, the moment diagram is parabola open upward with vertex at E.

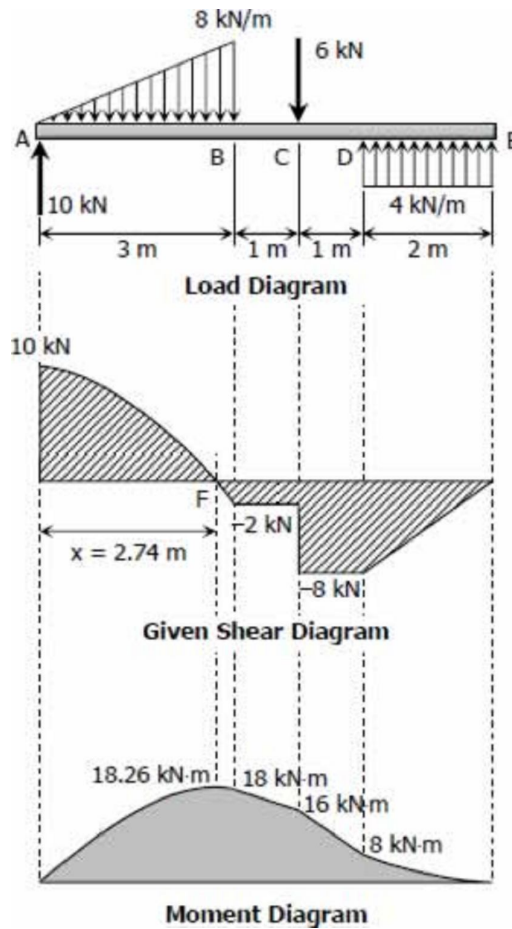

Moving Loads

Moving Loads

From the [previous section](#), we see that the maximum moment occurs at a point of zero shears. For beams loaded with concentrated loads, the point of zero shears usually occurs under a concentrated load and so the maximum moment.

Beams and girders such as in a bridge or an overhead crane are subject to moving concentrated loads,

which are at fixed distance with each other. The problem here is to determine the moment under each load when each load is in a position to cause a maximum moment. The largest value of these moments governs the design of the beam.

Single Moving Load

For a single moving load, the maximum moment occurs when the load is at the midspan and the maximum shear occurs when the load is very near the support (usually assumed to lie over the support).

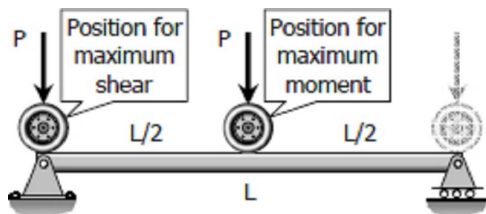

$$M_{max} = \frac{PL}{4} \text{ and } V_{max} = P$$

Two Moving Loads

For two moving loads, the maximum shear occurs at the reaction when the larger load is over that support. The maximum moment is given by

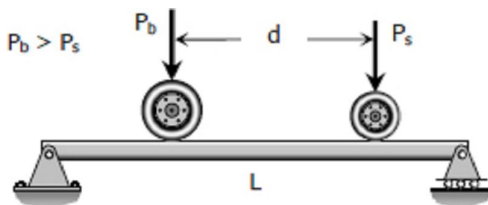

$$M_{max} = \frac{(PL - P_s d)^2}{4PL}$$

where P_s is the smaller load, P_b is the bigger load, and P is the total load ($P = P_s + P_b$).

Three or more moving loads

In general, the bending moment under a particular load is a maximum when the center of the beam is midway between that load and the resultant of all the loads then on the span. With this rule, we compute the maximum moment under each load, and use the biggest of the moments for the design. Usually, the biggest of these moments occurs under the biggest load.

The maximum shear occurs at the reaction where the resultant load is nearest. Usually, it happens if the biggest load is over that support and as many a possible of the remaining loads are still on the span.

In determining the largest moment and shear, it is sometimes necessary to check the condition when the bigger loads are on the span and the rest of the smaller loads are outside.

Solution to Problem 453 | Moving Loads

A truck with axle loads of 40 kN and 60 kN on a wheel base of 5 m rolls across a 10-m span. Compute the maximum bending moment and the maximum shearing force.

Solution 453

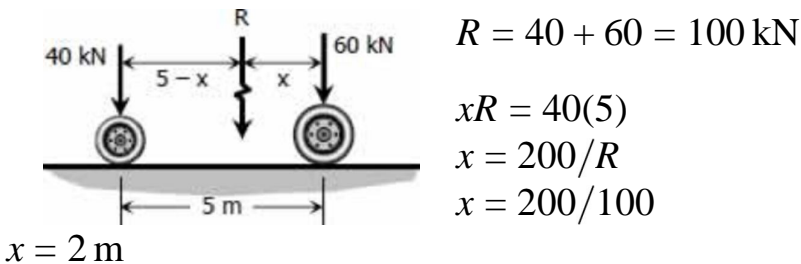

For maximum moment under 40 kN wheel:

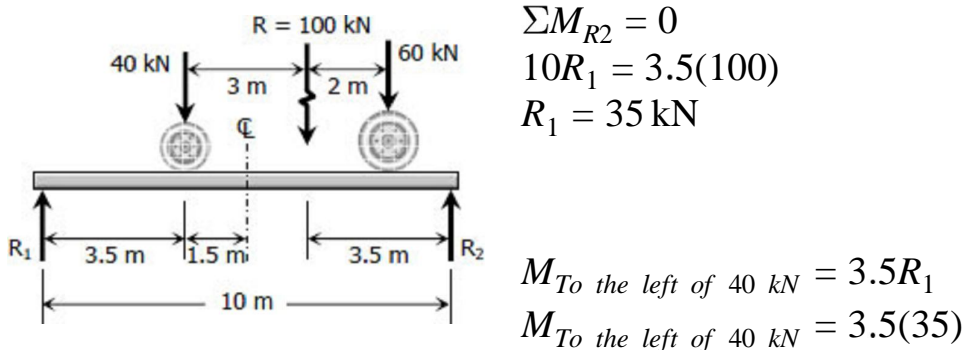

$$M_{To \text{ the left of } 40 \text{ kN}} = 122.5 \text{ kN} \cdot \text{m}$$

For maximum moment under 60 kN wheel:

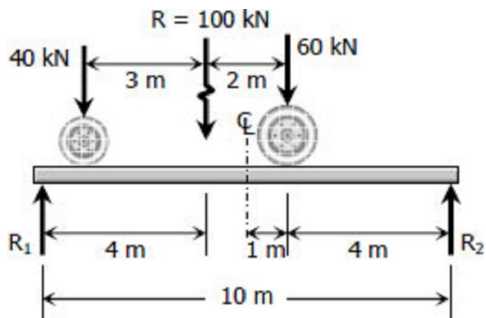

$$\begin{aligned} \sum M_{R1} &= 0 \\ 10R_2 &= 4(100) \\ R_2 &= 40 \text{ kN} \end{aligned}$$

$$\begin{aligned} M_{To \text{ the right of } 60 \text{ kN}} &= 4R_2 \\ M_{To \text{ the right of } 60 \text{ kN}} &= 4(40) \end{aligned}$$

$$M_{To \text{ the right of } 60 \text{ kN}} = 160 \text{ kN} \cdot \text{m}$$

Thus, $M_{max} = 160 \text{ kN} \cdot \text{m}$ *answer*

The maximum shear will occur when the 60 kN is over a support.

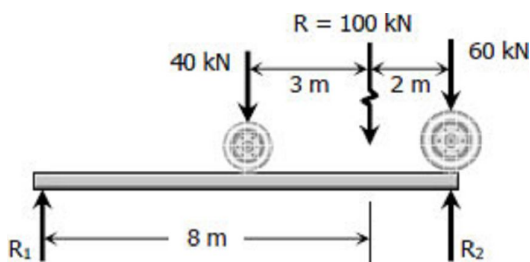

$$\begin{aligned} \sum M_{R1} &= 0 \\ 10R_2 &= 100(8) \\ R_2 &= 80 \text{ kN} \end{aligned}$$

Thus, $V_{max} = 80 \text{ kN}$ *answer*

Solution to Problem 454 | Moving Loads

Repeat [Prob. 453](#) using axle loads of 30 kN and 50 kN on a wheel base of 4 m crossing an 8-m span.

Solution 454

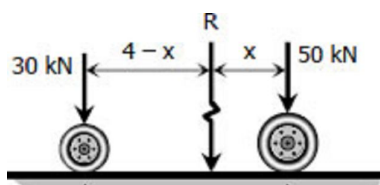

$$R = 30 + 50 = 80 \text{ kN}$$

$$xR = 4(30)$$

$$x = 120/R$$

 $x = 120/80$
 $x = 1.5 \text{ m}$

Maximum moment under 30 kN wheel:

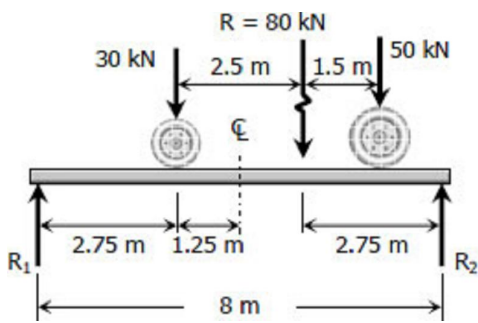

$$\begin{aligned} \sum M_{R2} &= 0 \\ 8R_1 &= 2.75(80) \\ R_1 &= 27.5 \text{ kN} \end{aligned}$$

$$\begin{aligned} M_{\text{To the left of 30 kN}} &= 2.75R_1 \\ M_{\text{To the left of 30 kN}} &= 2.75(27.5) \end{aligned}$$

$$M_{\text{To the left of 30 kN}} = 75.625 \text{ kN} \cdot \text{m}$$

Maximum moment under 50 kN wheel:

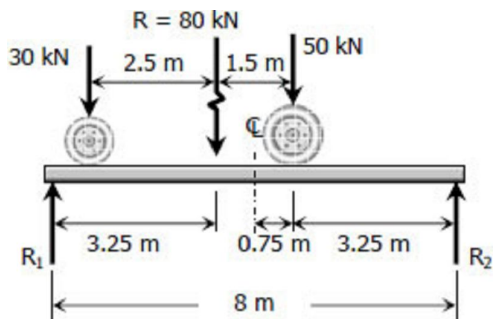

$$\begin{aligned} \sum M_{R1} &= 0 \\ 8R_2 &= 3.25(80) \\ R_2 &= 32.5 \text{ kN} \end{aligned}$$

$$\begin{aligned} M_{\text{To the right of 50 kN}} &= 3.25R_2 \\ M_{\text{To the right of 50 kN}} &= 3.25(32.5) \end{aligned}$$

$$M_{\text{To the right of 50 kN}} = 105.625 \text{ kN} \cdot \text{m}$$

Thus, $M_{\max} = 105.625 \text{ kN} \cdot \text{m}$ *answer*

The maximum shear will occur when the 50 kN is over a support.

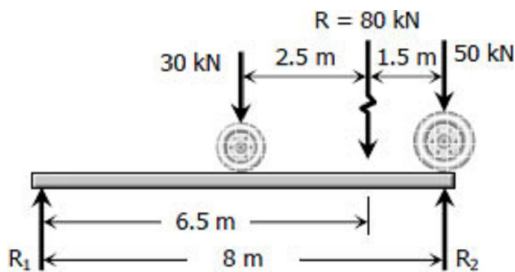

$$\begin{aligned} \sum M_{R1} &= 0 \\ 8R_2 &= 6.5(80) \\ R_2 &= 65 \text{ kN} \end{aligned}$$

Thus, $V_{\max} = 65 \text{ kN}$ *answer*

Solution to Problem 455 | Moving Loads

A tractor weighing 3000 lb, with a wheel base of 9 ft, carries 1800 lb of its load on the rear wheels. Compute the maximum moment and maximum shear when crossing a 14 ft-span.

Solution 455

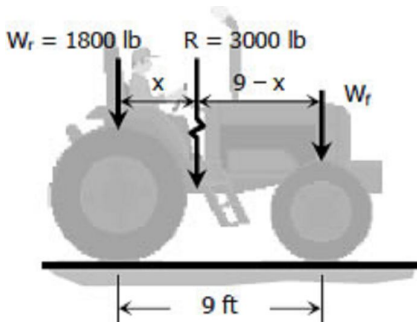

$$R = W_r + W_f$$

$$3000 = 1800 + W_f$$

$$W_f = 1200 \text{ lb}$$

$$Rx = 9W_f$$

$$3000x = 9(1200)$$

$$x = 3.6 \text{ ft}$$

$$9 - x = 5.4 \text{ ft}$$

When the midspan is midway between W_r and R , the front wheel W_f will be outside the span (see figure). In this case, only the rear wheel $W_r = 1800 \text{ lb}$ is the load. The maximum moment for this condition is when the load is at the midspan.

$$R_1 = R_2 = \frac{1}{2}(1800)$$

$$R_1 = 900 \text{ lb}$$

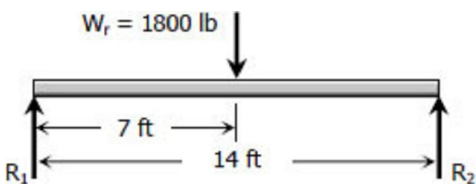
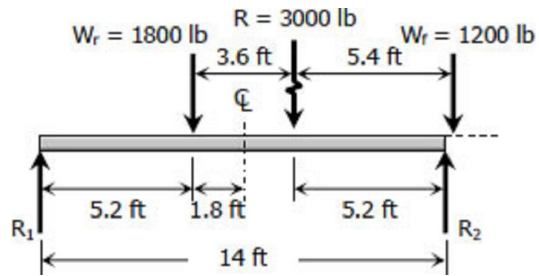

Maximum moment under W_r

$$M_{\text{To the left of rear wheel}} = 7R_1$$

$$M_{\text{To the left of rear wheel}} = 7(900)$$

$$M_{\text{To the left of rear wheel}} = 6300 \text{ lb} \cdot \text{ft}$$

Maximum moment under W_f

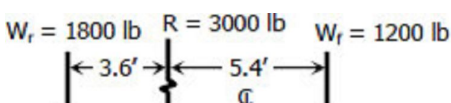

$$\sum M_{R1} = 0$$

$$14R_2 = 4.3R$$

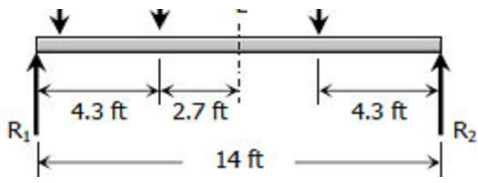

$$14R_2 = 4.3(3000)$$

$$R_2 = 921.43 \text{ lb}$$

$$M_{\text{To the right of front wheel}} = 4.3R_2$$

$$M_{\text{To the right of front wheel}} = 4.3(921.43)$$

$$M_{\text{To the right of front wheel}} = 3962.1 \text{ lb} \cdot \text{ft}$$

Thus,

$$M_{\text{max}} = M_{\text{To the left of rear wheel}}$$

$$M_{\text{max}} = 6300 \text{ lb} \cdot \text{ft} \text{ answer}$$

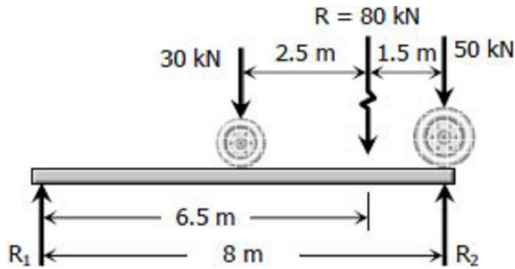

The maximum shear will occur when the rear wheel (wheel of greater load) is directly over the support.

$$\sum M_{R2} = 0$$

$$14R_1 = 10.4R$$

$$14R_1 = 10.4(3000)$$

$$R_1 = 2228.57 \text{ lb}$$

$$\text{Thus, } V_{\text{max}} = 2228.57 \text{ lb} \text{ answer}$$

Solution to Problem 456 | Moving Loads

Three wheel loads roll as a unit across a 44-ft span. The loads are $P_1 = 4000 \text{ lb}$ and $P_2 = 8000 \text{ lb}$ separated by 9 ft, and $P_3 = 6000 \text{ lb}$ at 18 ft from P_2 . Determine the maximum moment and maximum shear in the simply supported span.

Solution 456

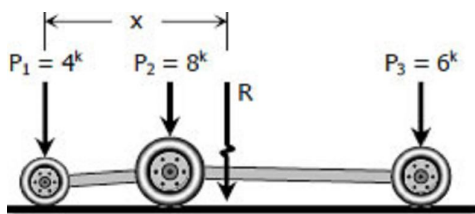

$$R = P_1 + P_2 + P_3$$

$$R = 4^k + 8^k + 6^k$$

$$R = 18 \text{ kips}$$

$$R = 18,000 \text{ lbs}$$



$$xR = 9P_2 + (9 + 18)P_3$$

$$x(18) = 9(8) + (9 + 18)(6)$$

$x = 13$ ft the resultant R is 13 ft from P_1

Maximum moment under P_1

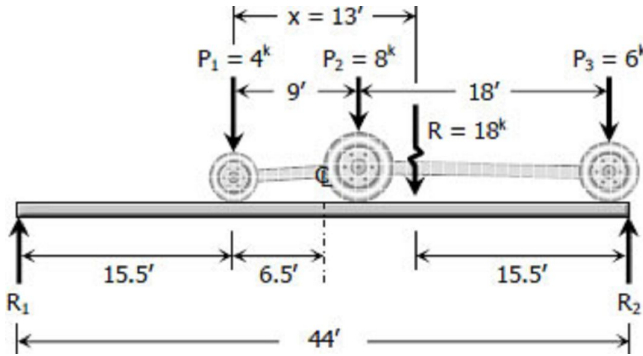

$$\Sigma M_{R2} = 0$$

$$44R_1 = 15.5R$$

$$44R_1 = 15.5(18)$$

$$R_1 = 6.34091 \text{ kips}$$

$$R_1 = 6,340.91 \text{ lbs}$$

$$M_{\text{To the left of } P_1} = 15.5R_1$$

$$M_{\text{To the left of } P_1} = 15.5(6340.91)$$

$$M_{\text{To the left of } P_1} = 98,284.1 \text{ lb} \cdot \text{ft}$$

Maximum moment under P_2

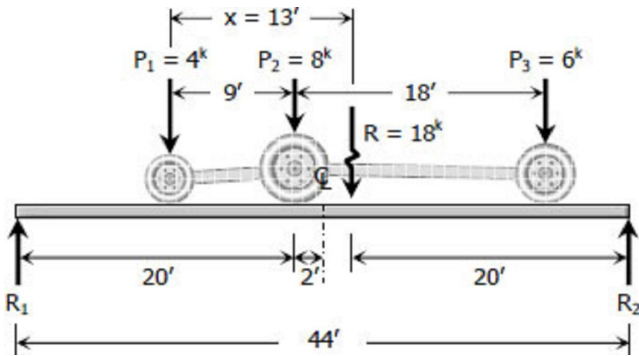

$$\Sigma M_{R2} = 0$$

$$44R_1 = 20R$$

$$44R_1 = 20(18)$$

$$R_1 = 8.18182 \text{ kips}$$

$$R_1 = 8,181.82 \text{ lbs}$$

$$M_{\text{To the left of } P_2} = 20R_1 - 9P_1$$

$$M_{\text{To the left of } P_2} = 20(8181.82) - 9(4000)$$

$$M_{\text{To the left of } P_2} = 127,636.4 \text{ lb} \cdot \text{ft}$$

Maximum moment under P_3

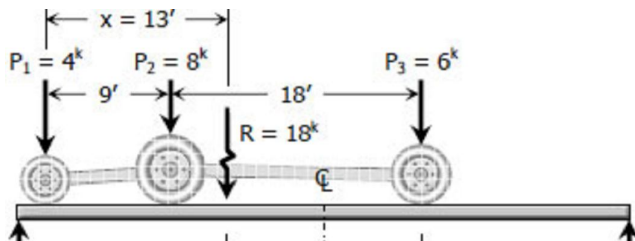

$$\Sigma R_1 = 0$$

$$44R_2 = 15R$$

$$44R_2 = 15(18)$$

$$R_2 = 6.13636 \text{ kips}$$

$$R_2 = 6,136.36 \text{ lbs}$$

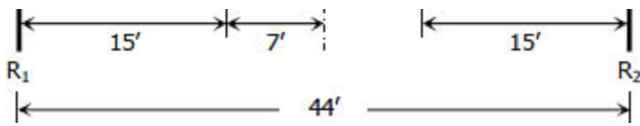

$$M_{To\ the\ right\ of\ P_3} = 15R_2$$

$$M_{To\ the\ right\ of\ P_3} = 15(6,136.36)$$

$$M_{To\ the\ right\ of\ P_3} = 92,045.4\ lb \cdot ft$$

Thus,

$$M_{max} = M_{To\ the\ left\ of\ P_2}$$

$$M_{max} = 127,636.4\ lb \cdot ft\ \text{answer}$$

The maximum shear will occur when P_1 is over the support.

$$\sum M_{R_2} = 0$$

$$44R_1 = 35R$$

$$44R_1 = 35(18)$$

$$R_1 = 14.3182\ kips$$

$$R_1 = 14,318.2\ lbs$$

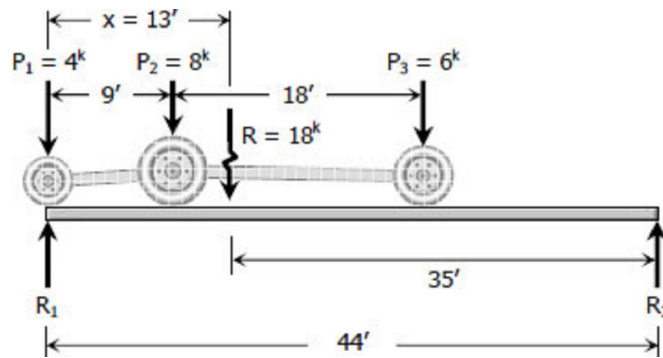

$$\text{Thus, } V_{max} = 14,318.2\ lbs\ \text{answer}$$

Solution to Problem 457 | Moving Loads

A truck and trailer combination crossing a 12-m span has axle loads of 10, 20, and 30 kN separated respectively by distances of 3 and 5 m. Compute the maximum moment and maximum shear developed in the span.

Solution 457

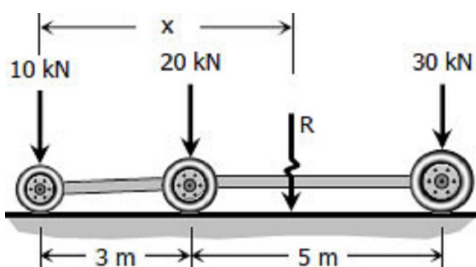

$$R = 10 + 20 + 30$$

$$R = 60\ kN$$

$$xR = 3(20) + 8(30)$$

$$x(60) = 3(20) + 8(30)$$

$$x = 5 \text{ m}$$

Maximum moment under 10 kN wheel load

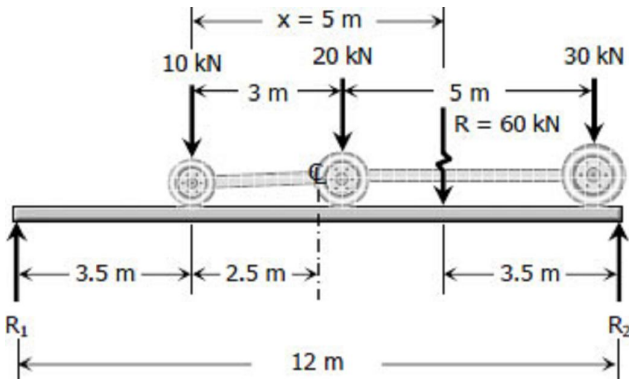

$$\begin{aligned} \Sigma M_{R2} &= 0 \\ 12R_1 &= 3.5R \\ 12R_1 &= 3.5(60) \\ 12R_1 &= 210 \\ R_1 &= 12.7 \text{ kN} \end{aligned}$$

$$\begin{aligned} M_{\text{To the left of 10 kN}} &= 3.5R_1 \\ M_{\text{To the left of 10 kN}} &= 3.5(12.7) \end{aligned}$$

$$M_{\text{To the left of 10 kN}} = 61.25 \text{ kN} \cdot \text{m}$$

Maximum moment under 20 kN wheel load

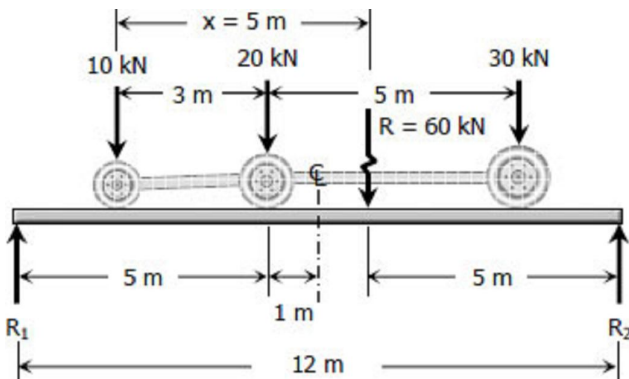

$$\begin{aligned} \Sigma M_{R2} &= 0 \\ 12R_1 &= 5R \\ 12R_1 &= 5(60) \\ R_1 &= 25 \text{ kN} \end{aligned}$$

$$\begin{aligned} M_{\text{To the left of 20 kN}} &= 5R_1 - 3(10) \\ M_{\text{To the left of 20 kN}} &= 5(25) - 30 \\ M_{\text{To the left of 20 kN}} &= 95 \text{ kN} \cdot \text{m} \end{aligned}$$

Maximum moment under 30 kN wheel load

When the centerline of the beam is midway between reaction $R = 60 \text{ kN}$ and 30 kN , the 10 kN comes off the span.

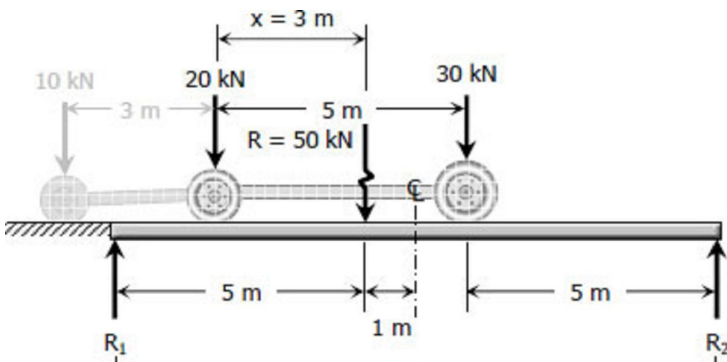

$$\begin{aligned} R &= 20 + 30 \\ R &= 50 \text{ kN} \end{aligned}$$

$$\begin{aligned} xR &= 5(30) \\ x(50) &= 150 \\ x &= 3 \text{ m from 20 kN wheel load} \end{aligned}$$

$$\left\langle \begin{array}{c} \text{---} 12 \text{ m} \text{---} \\ \leftarrow \qquad \qquad \qquad \rightarrow \end{array} \right\rangle \quad \begin{array}{l} \Sigma M_{R_1} = 0 \\ 12R_2 = 5R \end{array}$$

$$12R_2 = 5(50)$$

$$R_2 = 20.83 \text{ kN}$$

$$M_{\text{To the right of } 30 \text{ kN}} = 5R_2$$

$$M_{\text{To the right of } 30 \text{ kN}} = 5(20.83)$$

$$M_{\text{To the right of } 30 \text{ kN}} = 104.17 \text{ kN} \cdot \text{m}$$

Thus, the maximum moment will occur when only the 20 and 30 kN loads are on the span.

$$M_{\text{max}} = M_{\text{To the right of } 30 \text{ kN}}$$

$$M_{\text{max}} = 104.17 \text{ kN} \cdot \text{m} \text{ answer}$$

Maximum Shear

The maximum shear will occur when the three loads are on the span and the 30 kN load is directly over the support.

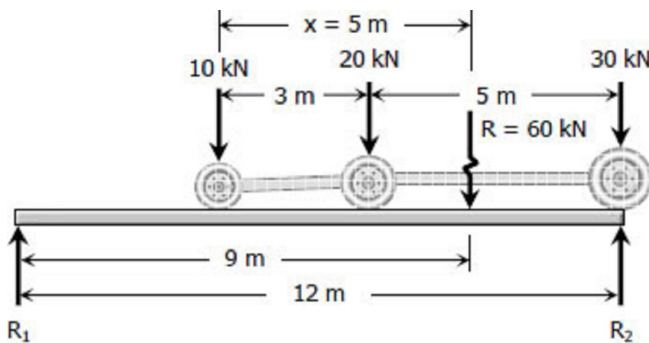

$$\Sigma M_{R_1} = 0$$

$$12R_2 = 9R$$

$$12R_2 = 9(60)$$

$$R_2 = 45 \text{ kN}$$

Thus, $V_{\text{max}} = 45 \text{ kN}$ answer

Chapter 5 - Stresses in Beams

Stresses in Beams

Forces and couples acting on the beam cause bending (flexural stresses) and shearing stresses on any cross section of the beam and deflection perpendicular to the longitudinal axis of the beam. If couples are applied to the ends of the beam and no forces act on it, the bending is said to be pure bending. If forces produce the bending, the bending is called ordinary bending.

Assumptions

In using the following formulas for flexural and shearing stresses, it is assumed that a plane section of the beam normal to its longitudinal axis prior to loading remains plane after the forces and couples have been applied, and that the beam is initially straight and of uniform cross section and that the moduli of elasticity in tension and compression are equal.

Flexure Formula

Flexure Formula

Stresses caused by the bending moment are known as flexural or bending stresses. Consider a beam to be loaded as shown.

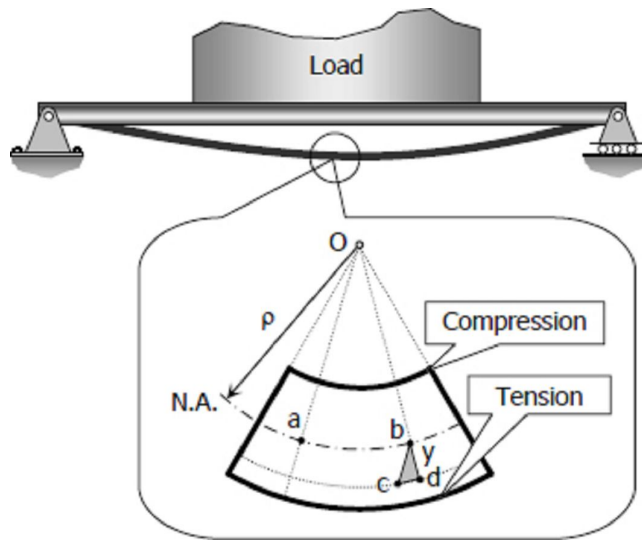

Consider a fiber at a distance y from the neutral axis, because of the beam's curvature, as the effect of bending moment, the fiber is stretched by an amount of cd . Since the curvature of the beam is very small, bcd and Oba are considered as similar triangles. The strain on this fiber is

$$\epsilon = \frac{cd}{ab} = \frac{y}{\rho}$$

By Hooke's law, $\epsilon = \sigma/E$, then

$$\frac{\sigma}{E} = \frac{y}{\rho}; \quad \sigma = \frac{y}{\rho} E$$

which means that the stress is proportional to the distance y from the neutral axis.

For this section, the notation f_b will be used instead of σ .

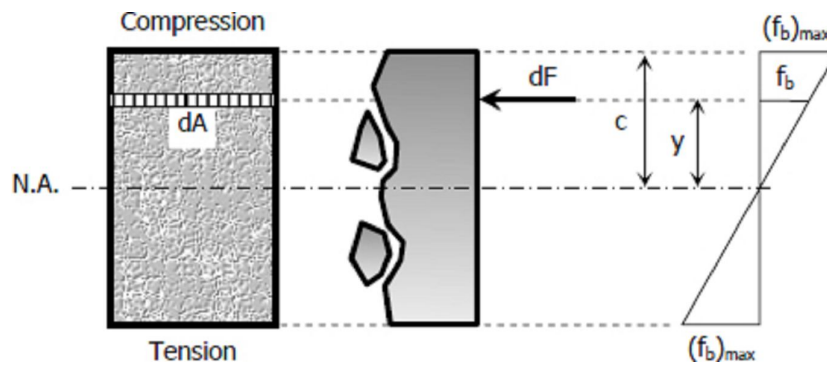

Considering a differential area dA at a distance y from N.A., the force acting over the area is

$$dF = f_b dA = \frac{y}{\rho} E dA = \frac{E}{\rho} y dA$$

The resultant of all the elemental moment about N.A. must be equal to the bending moment on the section.

$$M = \int M dF = \int y \left(\frac{E}{\rho} y dA \right)$$

$$M = \frac{E}{\rho} \int y^2 dA$$

but $\int y^2 dA = I$ then

$$M = \frac{EI}{\rho} \text{ or } \rho = \frac{EI}{M}$$

substituting $\rho = Ey/f_b$

$$\frac{Ey}{f_b} = \frac{EI}{M}$$

then

$$f_b = \frac{My}{I}$$

and

$$(f_b)_{max} = \frac{Mc}{I}$$

The **bending stress due to beams curvature** is

$$f_b = \frac{Mc}{I} = \frac{EI}{\rho} c$$

$$f_b = \frac{Ec}{\rho}$$

The **beam curvature** is:

$$k = \frac{1}{\rho}$$

where ρ is the radius of curvature of the beam in mm (in), M is the bending moment in N·mm (lb-in), f_b is the flexural stress in MPa (psi), I is the centroidal moment of inertia in mm⁴ (in⁴), and c is the distance from the neutral axis to the outermost fiber in mm (in).

Section Modulus

In the formula

$$(f_b)_{max} = \frac{Mc}{I} = \frac{M}{I/c}$$

the ratio I/c is called the section modulus and is usually denoted by S with units of mm³ (in³). The maximum bending stress may then be written as

$$(f_b)_{max} = \frac{M}{S}$$

This form is convenient because the values of S are available in handbooks for a wide range of standard structural shapes.

Solution to Problem 503 | Flexure Formula

A cantilever beam, 50 mm wide by 150 mm high and 6 m long, carries a load that varies uniformly from zero at the free end to 1000 N/m at the wall. (a) Compute the magnitude and location of the maximum flexural stress. (b) Determine the type and magnitude of the stress in a fiber 20 mm from the top of the beam at a section 2 m from the free end.

Solution 503

$$M = F\left(\frac{1}{3}x\right)$$

$$\frac{y}{x} = \frac{1000}{6}$$

$$y = \frac{500}{3}x$$

$$F = \frac{1}{2}xy$$

$$F = \frac{1}{2}x\left(\frac{500}{3}x\right)$$

$$F = \frac{250}{3}x^2$$

Thus,

$$M = \left(\frac{250}{3}x^2\right)\left(\frac{1}{3}x\right)$$

$$M = \frac{250}{9}x^3$$

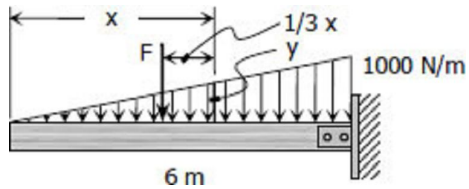

(a) The maximum moment occurs at the support (the wall) or at $x = 6$ m.

$$M = \frac{250}{9}x^3 = \frac{250}{9}(6^3)$$

$$M = 6000 \text{ N} \cdot \text{m}$$

$$(f_b)_{max} = \frac{Mc}{I} = \frac{Mc}{bh^3}$$

$$(f_b)_{max} = \frac{Mc}{I} = \frac{6000(1000)(75)}{\frac{50(150^3)}{12}}$$

$$(f_b)_{max} = 32 \text{ MPa } \textit{answer}$$

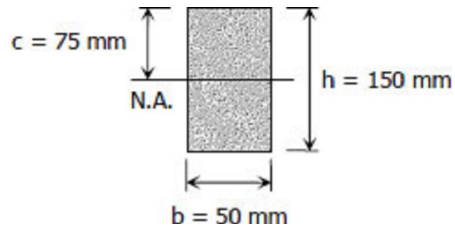

(b) At a section 2 m from the free end or at $x = 2$ m at fiber 20 mm from the top of the beam:

$$M = \frac{250}{9}x^3 = \frac{250}{9}(2^3)$$

$$M = \frac{2000}{9} \text{ N} \cdot \text{m}$$

$$f_b = \frac{My}{I} = \frac{\frac{2000}{9}(1000)(55)}{\frac{50(150^3)}{12}}$$

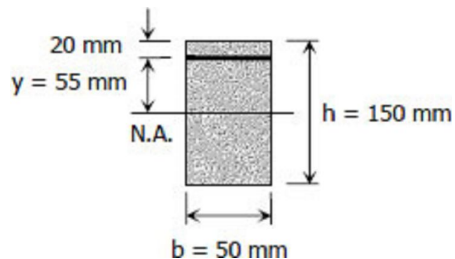

$$f_b = 0.8691 \text{ MPa} = 869.1 \text{ kPa} \text{ answer}$$

Solution to Problem 504 | Flexure Formula

A simply supported beam, 2 in wide by 4 in high and 12 ft long is subjected to a concentrated load of 2000 lb at a point 3 ft from one of the supports. Determine the maximum fiber stress and the stress in a fiber located 0.5 in from the top of the beam at midspan.

Solution 504

$$\begin{aligned} \sum M_{R_2} &= 0 \\ 12R_1 &= 9(2000) \\ R_1 &= 1500 \text{ lb} \end{aligned}$$

$$\begin{aligned} \sum M_{R_1} &= 0 \\ 12R_2 &= 3(2000) \\ R_2 &= 500 \text{ lb} \end{aligned}$$

Maximum fiber stress:

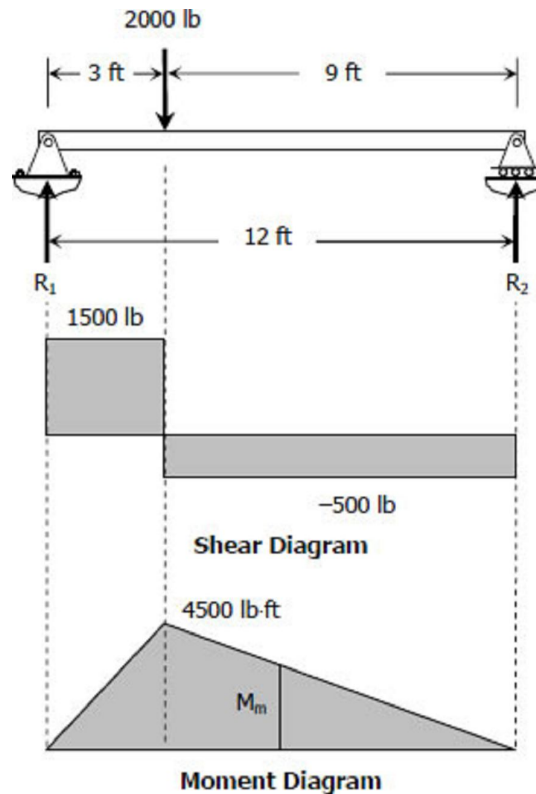
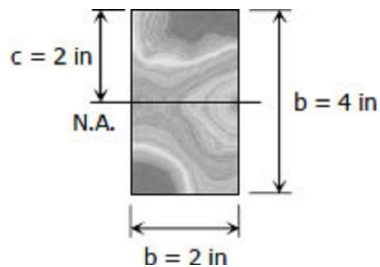

$$(f_b)_{max} = \frac{Mc}{I} = \frac{4500(12)(2)}{\frac{2(4^3)}{12}}$$

$$(f_b)_{max} = 10,125 \text{ psi} \text{ answer}$$

Stress in a fiber located 0.5 in from the top of the beam at midspan:

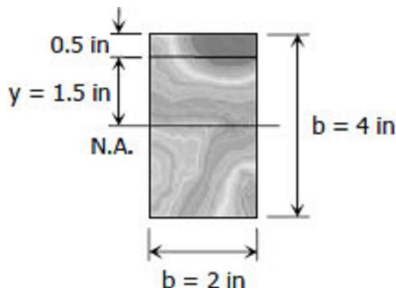

$$\frac{M_m}{6} = \frac{4500}{9}$$

$$M_m = 3000 \text{ lb} \cdot \text{ft}$$

$$f_b = \frac{My}{I}$$

$$f_b = \frac{3000(12)(1.5)}{\frac{2(4^3)}{12}}$$

$$f_b = 5,062.5 \text{ psi answer}$$

Solution to Problem 505 | Flexure Formula

A high strength steel band saw, 20 mm wide by 0.80 mm thick, runs over pulleys 600 mm in diameter. What maximum flexural stress is developed? What minimum diameter pulleys can be used without exceeding a flexural stress of 400 MPa? Assume $E = 200 \text{ GPa}$.

Solution 505

Flexural stress developed:

$$M = \frac{EI}{\rho}$$

$$f_b = \frac{Mc}{I} = \frac{(EI/\rho)c}{I}$$

$$f_b = \frac{Ec}{\rho} = \frac{200000(0.80/2)}{300}$$

$$f_b = 266.67 \text{ MPa}$$

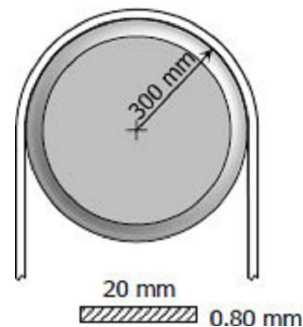

Minimum diameter of pulley:

$$f_b = \frac{Ec}{\rho}$$

$$400 = \frac{200000(0.80/2)}{\rho}$$

$$\rho = 200 \text{ mm}$$

diameter, $d = 400 \text{ mm}$ *answer*

Solution to Problem 506 | Flexure Formula

A flat steel bar, 1 inch wide by $\frac{1}{4}$ inch thick and 40 inches long, is bent by couples applied at the ends so that the midpoint deflection is 1.0 inch. Compute the stress in the bar and the magnitude of the couples.

Use $E = 29 \times 10^6$ psi.

Solution 506

$$\begin{aligned}
 (\rho - 1)^2 + 20^2 &= \rho^2 \\
 \rho^2 - 2\rho + 1 + 400 &= \rho^2 \\
 2\rho &= 401 \\
 \rho &= 200.5 \text{ in}
 \end{aligned}$$

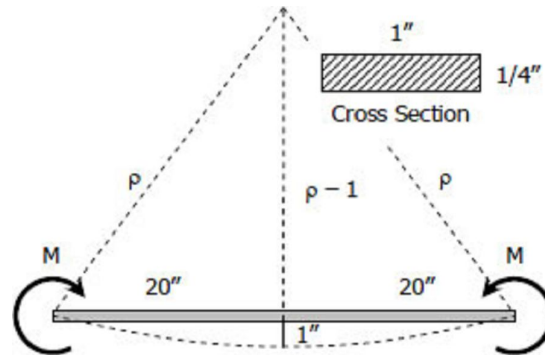

$$\begin{aligned}
 M &= \frac{EI}{\rho} \\
 f_b &= \frac{Mc}{I} = \frac{(EI/\rho)c}{I} \\
 f_b &= \frac{Ec}{\rho} = \frac{(29 \times 10^6)(1/8)}{200.5} \\
 f_b &= 18\,079.8 \text{ psi} \\
 f_b &= 18.1 \text{ ksi } \textit{answer}
 \end{aligned}$$

$$\begin{aligned}
 M &= \frac{EI}{\rho} = \frac{(29 \times 10^6) \frac{1(1/4)^3}{12}}{200.5} \\
 M &= 188.3 \text{ lb} \cdot \text{in } \textit{answer}
 \end{aligned}$$

Solution to Problem 507 | Flexure Formula

In a laboratory test of a beam loaded by end couples, the fibers at layer AB in Fig. P-507 are found to increase 60×10^{-3} mm whereas those at CD decrease 100×10^{-3} mm in the 200-mm-gage length. Using $E = 70$ GPa, determine the flexural stress in the top and bottom fibers.

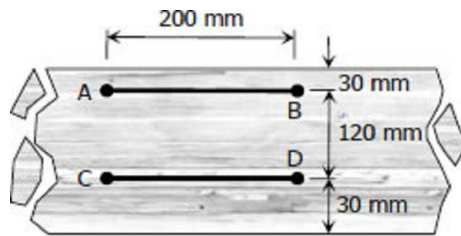
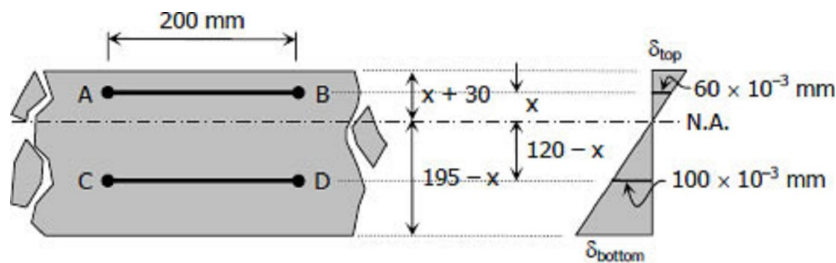

Figure P-507

Solution 507



$$\frac{x}{60 \times 10^{-3}} = \frac{120 - x}{100 \times 10^{-3}}$$

$$x = 0.6(120 - x)$$

$$x + 0.6x = 0.6(120)$$

$$1.6x = 72$$

$$x = 45 \text{ mm}$$

$$\frac{\delta_{top}}{x + 30} = \frac{60 \times 10^{-3}}{x}$$

$$\delta_{top} = \frac{60 \times 10^{-3}}{45} (4530)$$

$$\delta_{top} = 0.1 \text{ mm lengthening}$$

$$\frac{\delta_{bottom}}{195 - x} = \frac{100 \times 10^{-3}}{120 - x}$$

$$\delta_{bottom} = \frac{100 \times 10^{-3}}{120 - 45} (19545)$$

$$\delta_{bottom} = 0.2 \text{ mm shortening}$$

From Hooke's Law

$$f_b = E\varepsilon$$

$$f_b = \frac{E\delta}{L}$$

$$(f_b)_{top} = \frac{70\,000(0.1)}{200} = 35 \text{ MPa tension answer}$$

$$(f_b)_{bottom} = \frac{70\,000(0.2)}{200} = 70 \text{ MPa compression answer}$$

Solution to Problem 508 | Flexure Formula

Determine the minimum height h of the beam shown in [Fig. P-508](#) if the flexural stress is not to exceed 20 MPa.

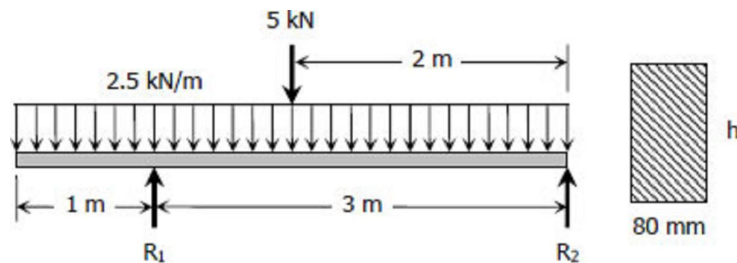
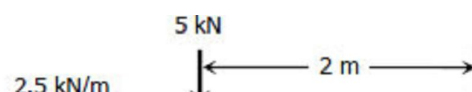

Figure P-508

Solution 508

$$\sum M_{R2} = 0$$



$$3R_1 = 2(5) + 2(2.5)(4)$$

$$R_1 = 10 \text{ kN}$$

$$\sum M_{R1} = 0$$

$$3R_2 = 1(5) + 1(2.5)(4)$$

$$R_2 = 5 \text{ kN}$$

$$f_b = \frac{Mc}{I}$$

Where:

$$f_b = 20 \text{ MPa}$$

$$M = 5 \text{ kN} \cdot \text{m} = 5(1000)^2 \text{ N} \cdot \text{mm}$$

$$c = \frac{1}{2}h$$

$$I = \frac{bh^3}{12} = \frac{80h^3}{12} = \frac{20}{3}h^3$$

$$20 = \frac{5(1000)^2(\frac{1}{2}h)}{\frac{20}{3}h^3}$$

$$h^2 = 18750$$

$$h = 137 \text{ mm } \textit{answer}$$

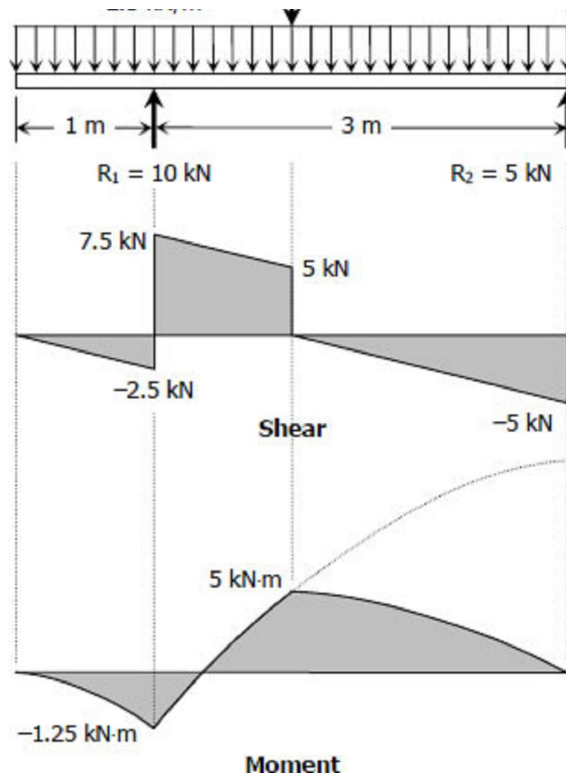

Solution to Problem 509 | Flexure Formula

A section used in aircraft is constructed of tubes connected by thin webs as shown in [Fig. P-509](#). Each tube has a cross-sectional area of 0.20 in^2 . If the average stress in the tubes is no to exceed 10 ksi, determine the total uniformly distributed load that can be supported in a simple span 12 ft long. Neglect the effect of the webs.

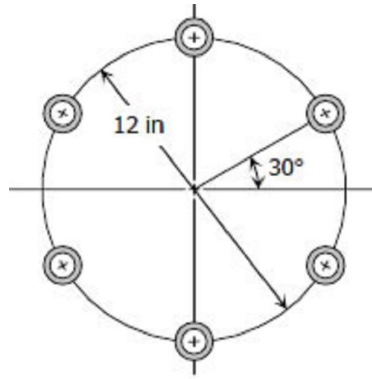

Figure P-509

Solution 509

$$R_1 = R_2 = \frac{1}{2}(12)(w)$$

$$R_1 = R_2 = 6w$$

$$f_b = 10 \text{ ksi} = 10,000 \text{ psi}$$

$$M = 18w \text{ lb} \cdot \text{ft}$$

$$c = 6$$

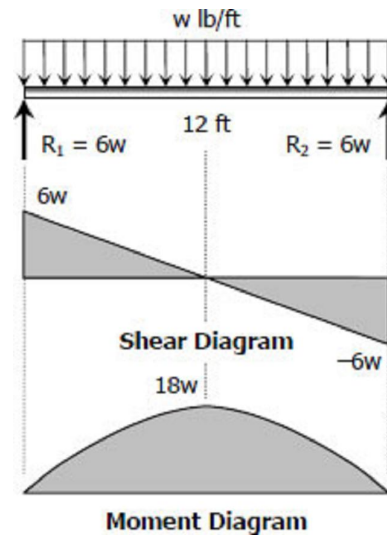

Centroidal moment of inertia of one tube:

$$A = \pi r^2 = 0.20$$

$r = 0.2523 \text{ in}$ hollow portion of the tube was neglected

$$\bar{I}_x = \frac{\pi r^4}{4} = \frac{\pi(0.2523^4)}{4}$$

$$\bar{I}_x = 0.0032 \text{ in}^4$$

Moment of inertia at the center of the section:

$$d_1 = 6 \sin 30^\circ = 3 \text{ in}$$

$$I_1 = \bar{I}_x + Ad_1^2$$

$$I_1 = 0.0032 + 0.2(3^2)$$

$$I_1 = 1.8 \text{ in}^4$$

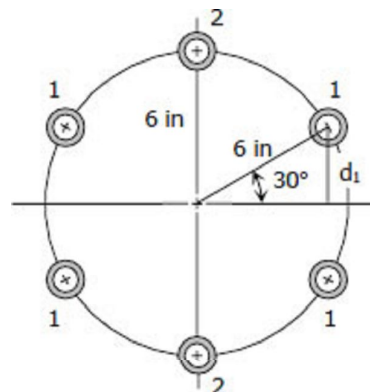

$$I_2 = \bar{I}_x + Ad_2^2$$

$$I_2 = 0.0032 + 0.2(6^2)$$

$$I_2 = 7.2 \text{ in}^4$$

$$I = 4I_1 + 2I_2 = 4(1.8) + 2(7.2)$$

$$I = 21.6 \text{ in}^4$$

$$f_b = \frac{Mc}{I}$$

$$10,000 = \frac{18w(12)(6)}{21.6}$$

$$w = 166.7 \text{ lb/ft } \textit{answer}$$

Solution to Problem 510 | Flexure Formula

A 50-mm diameter bar is used as a simply supported beam 3 m long. Determine the largest uniformly distributed load that can be applied over the right two-thirds of the beam if the flexural stress is limited to 50 MPa.

Solution 510

$$\sum M_{R1} = 0$$

$$3R_2 = 2w(2)$$

$$R_2 = \frac{4}{3}w$$

$$\sum M_{R2} = 0$$

$$3R_1 = 2w(1)$$

$$R_1 = \frac{2}{3}w$$

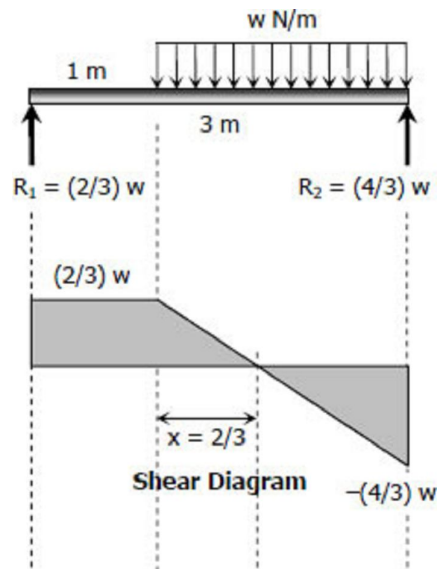

$$(f_b)_{max} = \frac{Mc}{I}$$

Where

$$(f_b)_{max} = 50 \text{ MPa}$$

$$M = \frac{8}{9} N \cdot m$$

$$c = 25 \text{ mm}$$

$$I = \frac{\pi r^4}{4} = \frac{\pi(25^4)}{4}$$

$$I = 97656.25\pi \text{ mm}^4$$

$$50 = \frac{\frac{8}{9}w(1000)(25)}{97656.25\pi}$$

$$w = 690.29 \text{ N/m}$$

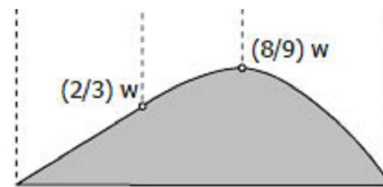

Moment Diagram

Solution to Problem 511 | Flexure Formula

A simply supported rectangular beam, 2 in wide by 4 in deep, carries a uniformly distributed load of 80 lb/ft over its entire length. What is the maximum length of the beam if the flexural stress is limited to 3000 psi?

Solution 511

By symmetry:

$$R_1 = R_2 = \frac{1}{2}(80L)$$

$$R_1 = R_2 = 40L$$

$$(f_b)_{max} = \frac{Mc}{I}$$

Where

$$(f_b)_{max} = 3000 \text{ psi}$$

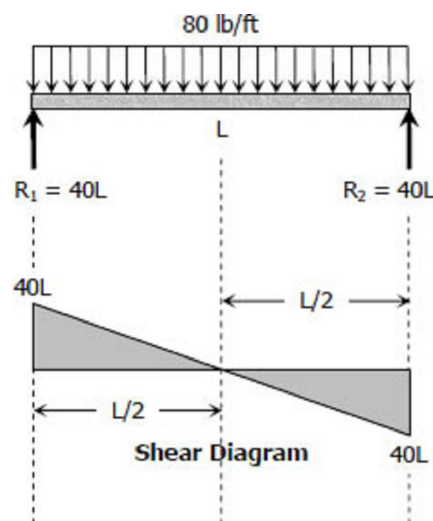

$$M = 10L^2 \text{ lb} \cdot \text{ft}$$

$$c = h/2 = 2 \text{ in}$$

$$I = \frac{bh^3}{12} = \frac{2(4^3)}{12} = \frac{32}{3} \text{ in}^4$$

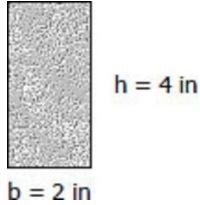
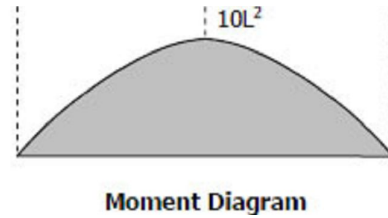

$$3000 = \frac{10L^2(12)(2)}{32/3}$$

$$L = 11.55 \text{ ft} \quad \text{\textit{answer}}$$

Solution to Problem 512 | Flexure Formula

The circular bar 1 inch in diameter shown in [Fig. P-512](#) is bent into a semicircle with a mean radius of 2 ft. If $P = 400 \text{ lb}$ and $F = 200 \text{ lb}$, compute the maximum flexural stress developed in section a-a. Neglect the deformation of the bar.

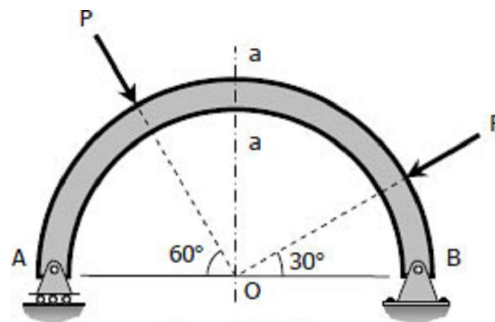

Solution 512

$$\sum M_B = 0$$

$$4R_A = 2(400 \sin 60^\circ) + 2(200 \sin 30^\circ)$$

$$R_A = 223.2 \text{ lb}$$

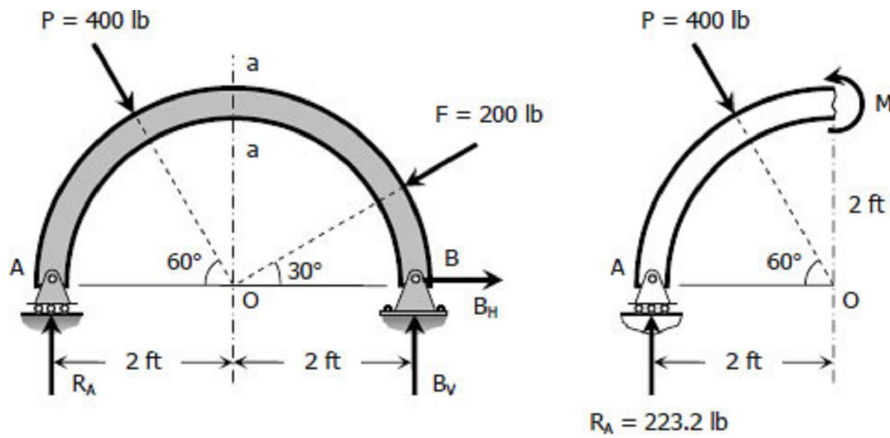

$$M = 2(223.2) - 2(400 \cos 60^\circ)$$

$$M = 46.4 \text{ lb} \cdot \text{ft}$$

$$(f_b)_{max} = \frac{Mc}{I} = \frac{Mr}{\pi r^4 / 4}$$

$$(f_b)_{max} = \frac{4M}{\pi r^3} = \frac{4(46.4)(12)}{\pi(0.5^3)}$$

$$(f_b)_{max} = 5671.52 \text{ psi answer}$$

Solution to Problem 513 | Flexure Formula

A rectangular steel beam, 2 in wide by 3 in deep, is loaded as shown in [Fig. P-513](#). Determine the magnitude and the location of the maximum flexural stress.

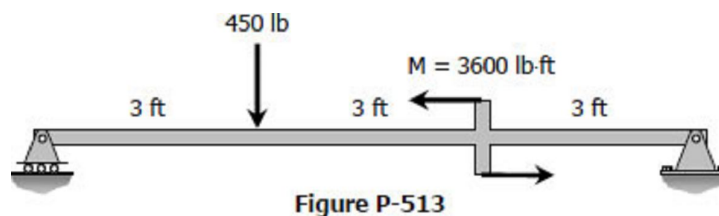

Solution 513

$$\Sigma M_{R_2} = 0$$

$$9R_1 = 6(450) + 3600$$

$$R_1 = 700 \text{ lb}$$

$$\Sigma M_{R_1} = 0$$

$$9R_2 + 3(450) = 3600$$

$$R_2 = 250 \text{ lb}$$

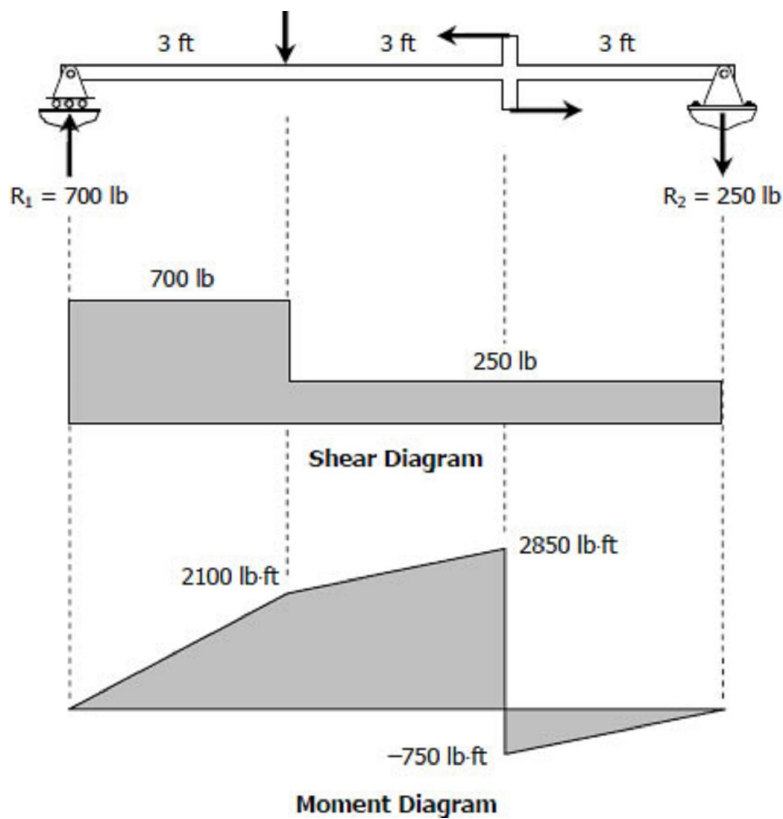

$$(f_b)_{max} = \frac{Mc}{I}$$

Where

$$M = 2850 \text{ lb} \cdot \text{ft}$$

$$c = h/2 = 3/2 = 1.5 \text{ in}$$

$$I = \frac{bh^3}{12} = \frac{2(3^3)}{12} = 4.5 \text{ in}^4$$

$$(f_b)_{max} = \frac{2850(12)(1.5)}{4.5}$$

$$(f_b)_{max} = 11400 \text{ psi @ 3 ft from right support } \textit{answer}$$

Solution to Problem 514 | Flexure Formula

The right-angled frame shown in [Fig. P-514](#) carries a uniformly distributed loading equivalent to 200 N for each horizontal projected meter of the frame; that is, the total load is 1000 N. Compute the maximum flexural stress at section a-a if the cross-section is 50 mm square.

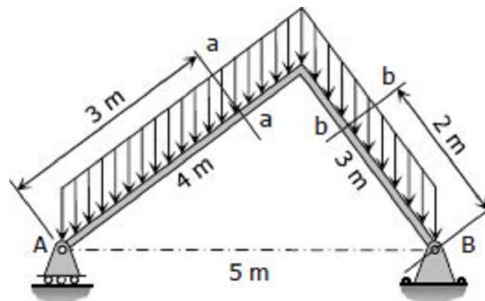

Figure P-514 and P-515

Solution 514

By symmetry

$$R_A = 500 \text{ N}$$

$$R_B = 500 \text{ N}$$

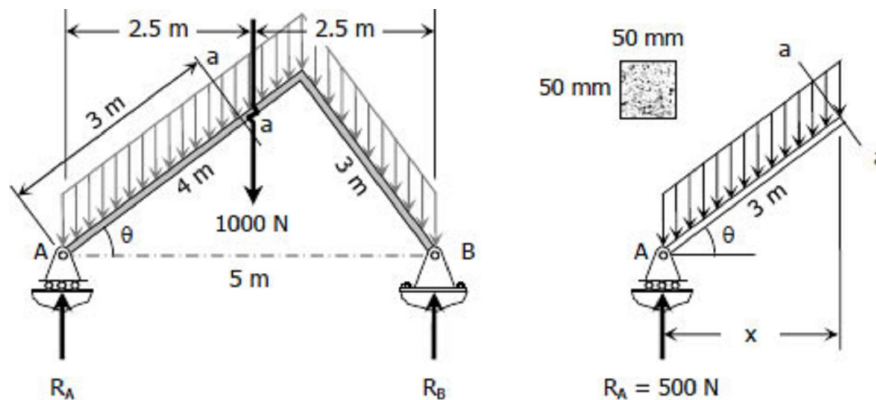

At section a-a:

$$\cos \theta = \frac{x}{3} = \frac{4}{5}$$

$$x = 2.4 \text{ m}$$

$$M = xR_A - 200x(x/2)$$

$$M = 2.4(500) - 200(2.4)(2.4/2)$$

$$M = 624 \text{ N} \cdot \text{m}$$

$$f_b = \frac{Mc}{I} = \frac{624(1000)(50/2)}{\frac{50(50^3)}{12}}$$

$$f_b = 29.952 \text{ MPa}$$

Solution to Problem 515 | Flexure Formula

Repeat [Prob. 524](#) to find the maximum flexural stress at section b-b.

Solution 515

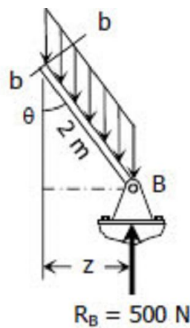
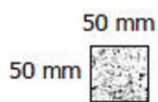

At section b-b:

$$\sin \theta = \frac{z}{2} = \frac{3}{5}$$

$$z = 1.5 \text{ m}$$

$$M = zR_B - 200z(z/2)$$

$$M = 1.5(500) - 200(1.5)(1.5/2)$$

$$M = 525 \text{ N} \cdot \text{m}$$

$$f_b = \frac{Mc}{I} = \frac{525(1000)(50/2)}{\frac{50(50^3)}{12}}$$

$$f_b = 25.2 \text{ MPa } \textit{answer}$$

Solution to Problem 516 | Flexure Formula

A timber beam AB, 6 in wide by 10 in deep and 10 ft long, is supported by a guy wire AC in the position shown in [Fig. P-516](#). The beam carries a load, including its own weight, of 500 lb for each foot of its length. Compute the maximum flexural stress at the middle of the beam.

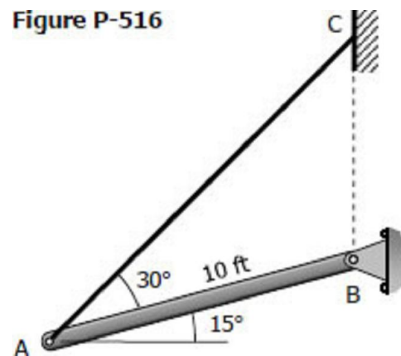

Solution 516

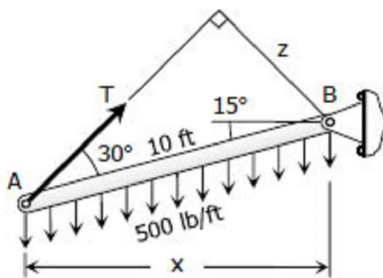

$$x = 10 \cos 15^\circ$$

$$x = 9.66 \text{ ft}$$

$$z = 10 \sin 30^\circ$$

$$z = 5 \text{ ft}$$

$$\Sigma M_B = 0$$

$$zT = 500(10)(x/2)$$

$$5T = 500(10)(9.66/2)$$

$$T = 4829.63 \text{ lb}$$

At midspan:

$$M = T(z/2) - 500(5)(x/4)$$

$$M = 4829.63(5/2) - 500(5)(9.66/4)$$

$$M = 6036.58 \text{ lb} \cdot \text{ft}$$

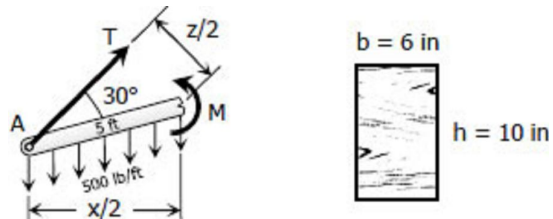

$$f_b = \frac{Mc}{I} = \frac{M(h/2)}{\frac{bh^3}{12}}$$

$$f_b = \frac{6036.58(12)(10/2)}{6(10^3)}$$

$$f_b = 724.39 \text{ psi answer}$$

Solution to Problem 517 | Flexure Formula

A rectangular steel bar, 15 mm wide by 30 mm high and 6 m long, is simply supported at its ends. If the density of steel is 7850 kg/m^3 , determine the maximum bending stress caused by the weight of the bar.

Solution 517

$$w = (7850 \text{ kg/m}^3)(0.015 \text{ m} \times 0.03 \text{ m})$$

$$w = (3.5325 \text{ kg/m})(9.81 \text{ m/s}^2)$$

$$w = 34.65 \text{ N/m}$$

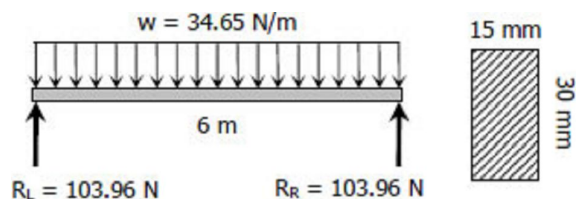

$$R_L = R_R = 6w/2$$

$$R_L = R_R = 6(34.65)/2$$

$$R_L = R_R = 103.96 \text{ N}$$

For simply supported beam subjected to uniformly distributed load, the maximum moment will occur at the midspan. At midspan:

$$M = 3(103.96) - 34.65(3)(3/2)$$

$$M = 155.955 \text{ N} \cdot \text{m}$$

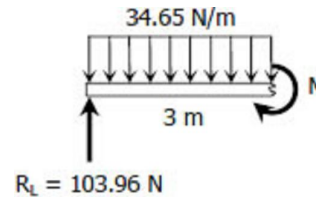

$$(f_b)_{max} = \frac{Mc}{I} = \frac{M(h/2)}{\frac{bh^3}{12}}$$

$$(f_b)_{max} = \frac{155.955(1000)(30/2)}{\frac{15(30^3)}{12}}$$

$$(f_b)_{max} = 69.31 \text{ MPa } \textit{answer}$$

Solution to Problem 518 | Flexure Formula

A cantilever beam 4 m long is composed of two C200 × 28 channels riveted back to back. What uniformly distributed load can be carried, in addition to the weight of the beam, without exceeding a flexural stress of 120 MPa if (a) the webs are vertical and (b) the webs are horizontal? Refer to Appendix B of [text book](#) for channel properties.

Solution 518

Relevant data from Appendix B, Table B-4 Properties of Channel Sections: SI Units, of [text book](#).

Designation	C200 × 28
Area	3560 mm ²
Width	64 mm
S _{X-X}	180 × 10 ³ mm ³

I_{Y-Y}	0.825×10^6 mm^4
x	14.4 mm

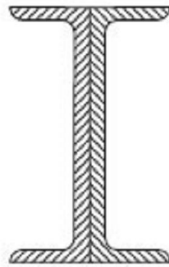
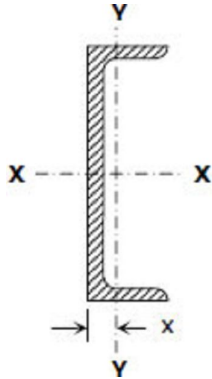

Webs are Vertical

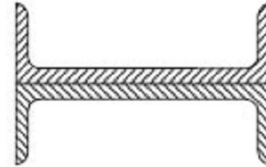

Webs are horizontal

a. Webs are vertical

$$(f_b)_{max} = \frac{M}{S}$$

$$120 = \frac{M}{2(180 \times 10^3)}$$

$$M = 43,200,000 \text{ N} \cdot \text{mm}$$

$$M = 43.2 \text{ kN} \cdot \text{m}$$

From the figure:

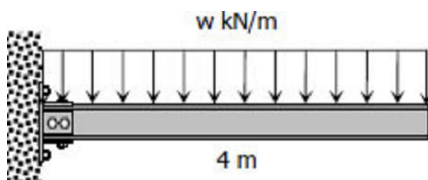

$$M = 4w(2)$$

$$M = 8w$$

$$43.2 = 8w$$

$$w = 5.4 \text{ kN/m}$$

$$w = 550.46 \text{ kg/m}$$

$w = \text{dead load, } DL + \text{live load, } LL$

$$550.46 = 2(28) + LL$$

$$LL = 494.46 \text{ kg/m answer}$$

b. Webs are horizontal

$$I_{back} = I_{Y-Y} + Ax^2$$

$$I_{back} = (0.825 \times 10^6) + 3560(14.4^2)$$

$$I_{back} = 1\,563\,201.6 \text{ mm}^4$$

$$I = 2I_{back} = 2(1\,563\,201.6)$$

$$I = 3\,126\,403.2 \text{ mm}^4$$

$$(f_b)_{max} = \frac{Mc}{I}$$

$$120 = \frac{M(64)}{3\,126\,403.2}$$

$$M = 5\,862\,006 \text{ N} \cdot \text{mm}$$

$$M = 5.862 \text{ kN} \cdot \text{m}$$

From the figure:

$$M = 4w(2)$$

$$M = 8w$$

$$5.862 = 8w$$

$$w = 0.732\,75 \text{ kN/m}$$

$$w = 74.69 \text{ kg/m}$$

$w =$ dead load, DL + live load, LL

$$74.69 = 2(28) + LL$$

$$LL = 18.69 \text{ kg/m } \textit{answer}$$

Solution to Problem 519 | Flexure Formula

A 30-ft beam, simply supported at 6 ft from either end carries a uniformly distributed load of intensity w_0 over its entire length. The beam is made by welding two S18 \times 70 (see appendix B of text book) sections along their flanges to form the section shown in [Fig. P-519](#). Calculate the maximum value of w_0 if the flexural stress is limited to 20 ksi. Be sure to include the weight of the beam.

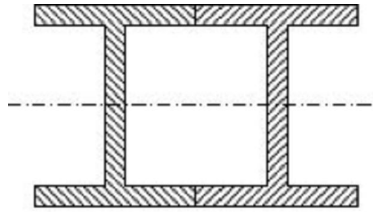
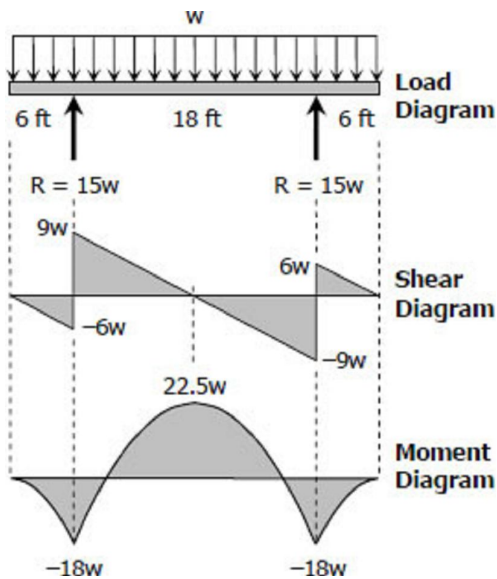

Figure P-519

Solution 519

Relevant data from Appendix B, Table B-8 Properties of I-Beam Sections (S-Shapes): US Customary Units, of [text book](#).

Designation	S18 × 70
S	103 in ³



$$(f_b)_{max} = \frac{M}{S}$$

$$20 = \frac{M}{2(103)}$$

$$M = 4120 \text{ kip} \cdot \text{in}$$

$$M = \frac{1030}{3} \text{ kip} \cdot \text{ft}$$

From the moment diagram:

$$M = 22.5w$$

$$\frac{1030}{3} = 22.5w$$

$$w = 15.26 \text{ kip/ft}$$

w = dead load, DL + live load, w_o

$$15.26(1000) = 2(70) + w_o$$

$$w_o = 15\,120 \text{ lb/ft}$$

$$w_o = 15.12 \text{ kip/ft } \textit{answer}$$

Solution to Problem 520 | Flexure Formula

A beam with an S310 × 74 section (see Appendix B of textbook) is used as a simply supported beam 6 m long. Find the maximum uniformly distributed load that can be applied over the entire length of the beam, in addition to the weight of the beam, if the flexural stress is not to exceed 120 MPa.

Solution 520

Relevant data from Appendix B, Table B-4 Properties of I-Beam Sections (S-Shapes): SI Units, of text book.

Designation	S310 × 74
S	833×10^3 mm ³

From the shear diagram:

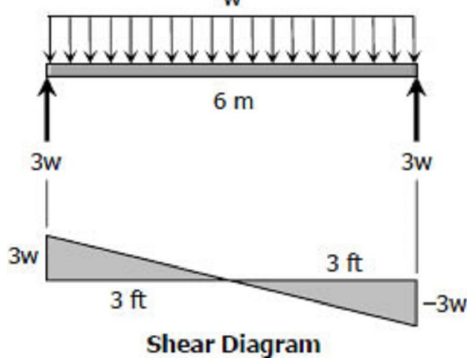

$$M_{max} = \frac{1}{2}(3)(3w)$$

$$M_{max} = 4.5w \text{ N} \cdot \text{m}$$

$$(f_b)_{max} = \frac{M}{S}$$

$$120 = \frac{4.5w(1000)}{833 \times 10^3}$$

$$w = 22,213.33 \text{ N/m}$$

$$w = 2,264.36 \text{ kg/m}$$

$$w = DL + LL$$

$$2,264.36 = 74 + LL$$

$$LL = 2,190.36 \text{ kg/m}$$

$$LL = 21.5 \text{ kN/m answer}$$

Economic Sections

From the flexure formula $f_b = My/I$, it can be seen that the bending stress at the neutral axis, where $y = 0$, is zero and increases linearly outwards. This means that for a rectangular or circular section a large portion of the cross section near the middle section is understressed.

For steel beams or composite beams, instead of adopting the rectangular shape, the area may be arranged so as to give more area on the outer fiber and maintaining the same overall depth, and saving a lot of weight.

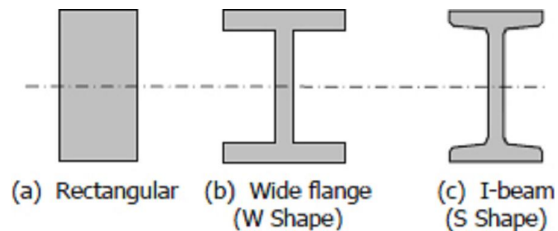

When using a wide flange or I-beam section for long beams, the compression flanges tend to buckle horizontally sidewise. This buckling is a column effect, which may be prevented by providing lateral support such as a floor system so that the full allowable stresses may be used, otherwise the stress should be reduced. The reduction of stresses for these beams will be discussed in steel design.

In selecting a structural section to be used as a beam, the resisting moment must be equal or greater than the applied bending moment. Note: $(f_b)_{max} = M/S$.

$$S_{required} \geq S_{live-load} \text{ or } S_{required} \geq \frac{M_{live-load}}{(f_b)_{max}}$$

The equation above indicates that the required section modulus of the beam must be equal or greater than the ratio of bending moment to the maximum allowable stress.

A check that includes the weight of the selected beam is necessary to complete the calculation. In checking, the beams resisting moment must be equal or greater than the sum of the live-load moment caused by the applied loads and the dead-load moment caused by dead weight of the beam.

$$M_{resisting} \geq M_{live-load} + M_{dead-load}$$

Dividing both sides of the above equation by $(f_b)_{max}$, we obtain the checking equation

$$S_{resisting} \geq S_{live-load} + S_{dead-load}$$

Floor framing

In floor framing, the subfloor is supported by light beams called **floor joists** or simply **joists** which in turn supported by heavier beams called **girders** then girders pass the load to columns. Typically, joist act as simply supported beam carrying a uniform load of magnitude p over an area of sL , where

p = floor load per unit area

L = length (or span) of joist

s = center to center spacing of joists and

$w_o = sp$ = intensity of distributed load in joist.

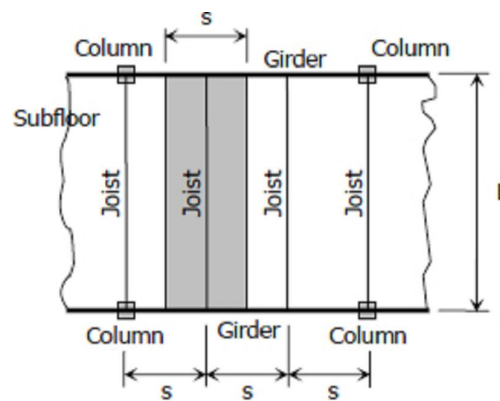

Typical Floor Framing Plan